

HP4590

900MHz Wireless Headphone System



User's Manual

INTRODUCTION

This 900Mhz cordless and corded stereo headphones takes advantage of the very latest advances in wireless transmission technology so that you can listen to stereo sound from your audio source up to 50 meters. All you have to do is connect the transmitter to any audio source: DVD player, CD player, MP3, TV set, VCR, Hi-Fi system or radio.

FEATURES

1. Auto Scanning system on headphones
2. Phase Lock Loop (PLL) transmission system on transmitter
3. Automatic battery recharging
4. 900 MHz RF technology.
5. RF technology leaves you completely free to move around.
6. Transmission is not restricted solely to line of sight.
7. Rechargeable receiver headphones.
8. Charger built into the transmitter.
9. High quality stereo sound that is virtually interference-free.
10. Automatic Level Control (ALC) and Auto On/Off function.

Part List

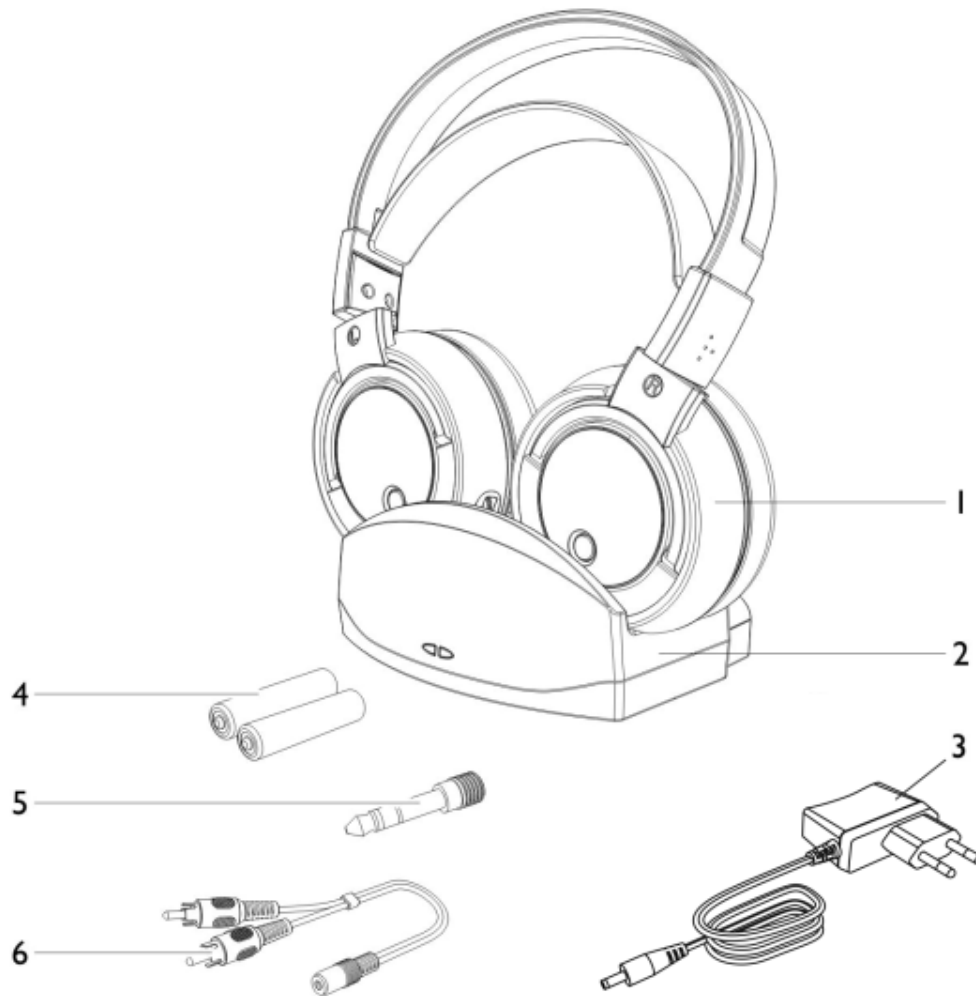

- 1 RF receiver headphones
- 2 RF transmitter
- 3 8V 200mA mains adapter
- 4 Rechargeable 1.2V Ni-MH batteries (LR03/AAA size)
- 5 Jack plug adapter (3.5 mm/6.3 mm diameter)
- 6 RCA socket audio adapter

COMPONENT IDENTIFICATION

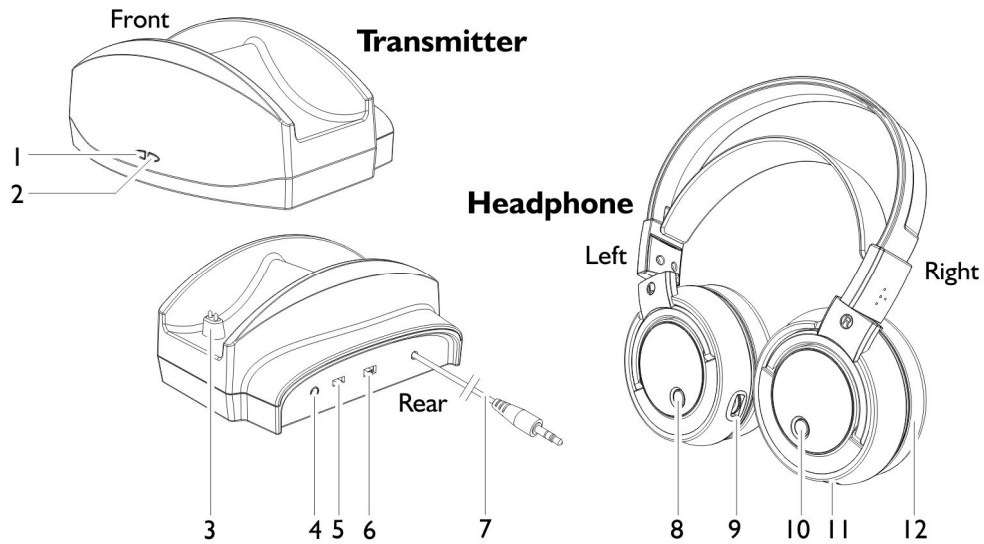

- 1 Charge indicator light (green)
- 2 Power indicator light (red)
- 3 Charge contacts
- 4 DC IN connector
- 5 Power On/Off switch
- 6 Channel selector (CHANNEL 3 2 1)
- 7 Audio connection cable with 3.5 mm audio plug
- 8 AUTO SCAN button / Signal indicator light (green)
- 9 Volume control knob (VOL)
- 10 Power indicator light (red)
- 11 Charge contacts
- 12 Ear cushion

INSTALLATION

TRANSMITTER

1. Connect the mains adapter provided to an electrical outlet.
2. Connect the mains adapter cable to the DC IN input connector located on the transmitter rear panel.
3. An audio cable is provided from the transmitter rear panel that can be connected to the headphone output jack of TV set, Hi-Fi system, VCR, MP3 or radio-cassette player. The audio cable can also be connected to the audio source with output jack (Left and Right) by means of the RCA socket adaptor provided.

The red Power Indicator will light up as soon as you have connected the power adapter to the mains outlet. Transmitter will automatically switch OFF in four minutes if there is no audio signal can be detected. However, transmitter will automatically switch ON once audio signal can be detected.

RECEIVER HEADPHONES

1. Move out the earpad holder from the right hand side (R) of receiver headphones.
2. Insert two rechargeable LR03/AAA size batteries, and ensure batteries have inserted correctly according to the polarity.
3. Put back the earpad holder to the right hand side of receiver headphones.
4. Switch off the receiver headphones and place it into the transmitter to charge the batteries before the first use. Headphones will be fully charged in approximate of six hours.

OPERATION

1. Switch on the audio source (TV set or audio component) that the transmitter is connected to, and the red Power indicator will light up
2. Place the receiver headphones On/Off switch in the On position, and the red Power indicator will light up
3. The green Signal indicator will light up once signal link between transmitter and receiver headphones is established
4. Place the receiver headphones on your head and adjust the volume to obtain the desired sound level.
5. If you cannot find the best reception frequency, press the "Auto Scan" button on the receiver headphones.

NOTE:

You should then be able to move around freely from one room to another without any interference. If interference does occur (interruptions in the signal), press the "Auto Scan" button once to find a better reception channel.

- A For better stereo reception, stay approximately seven meters away from the transmitter when you press the "Auto Scan" button on the receiver headphones.
- B If it is impossible to find a satisfactory frequency, change the frequency channel of the transmitter, then press the "Auto Scan" button on the receiver headphones to find the corresponding channel.

In order to protect the transmitter and save power, the transmitter will automatically switch OFF after an approximately of four minutes if there is no audio signal, or the signal that it receives from the audio source is too weak for proper reception. However, if the signal returns to an acceptable level, then the transmitter will automatically switch ON again.

CHARGING THE BATTERIES

1. Place the On/Off switch on the receiver headphones in the Off position.
2. To recharge the headphones batteries, place the receiver headphones on the

transmitter, and ensure the charge contacts touch the transmitter's charge prongs and the green Charging Indicator is ON.

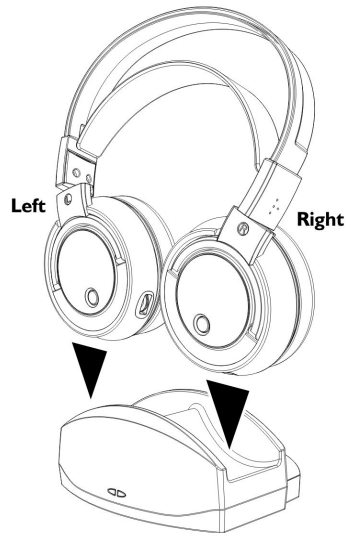

3. The charge process starts automatically and the green Charging Indicator light comes ON. Be sure to charge new batteries before using them for the first time. The green indicator light will be ON during the charging process, and will turn OFF when batteries are fully charged.

WARNING:

Never attempt to recharge conventional dry cells.

Never use another type of battery or non-rechargeable batteries to replace the rechargeable (LR03/AAA) batteries supplied. When the receiver headphones are not in use, move the switch to the OFF position to avoid damaging the batteries.

The batteries must always be fully charged before first use. An approximate of 6 hours charging time is required to guarantee an acceptable service life for the rechargeable batteries. Always ensure that the headphone is switched to the Off position while the batteries are charging.

IMPORTANT:

This unit should be operated with rechargeable batteries only. When replacing the batteries or when disposing of the unit, always comply with applicable laws relating to the disposal of batteries. Please place them in a proper disposal container to ensure that they are eliminated safely and in an environmentally-friendly way.

REPLACING BATTERIES

Rechargeable batteries have a long service life. If it is however necessary to replace them, proceed as described below:

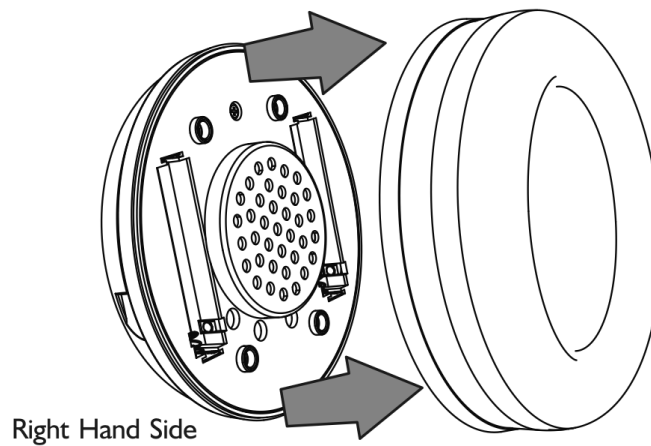

1. Carefully pull out the right-side (R) earpad holder from the receiver headphones. Install the 2 new rechargeable batteries in their housings as illustrated. Check the correct +/- polarity.
2. Put back the earpad holder into the receiver headphones and make sure to align the plastic holding slots on the receiver headphones.

Only use rechargeable batteries of the type specified under the "Technical specifications" heading.

The rechargeable batteries supplied with the receiver headphones must absolutely not be taken apart, disposed of in an open fire or short circuited.

TECHNICAL SPECIFICATIONS

Transmission mode	: UHF stereo
Carrier frequency	: 900Mhz
Operating voltage	: Transmitter : 8V 200mA Receiver : 2.4V (two rechargeable batteries, LR03/AAA size)
Frequency response	: 30 Hz – 11 KHz
Distortion	: 1%
Signal-to-noise ratio	: 54 dB
Channel separation	: 30 dB
Range	: 50 meters (open area)

This device complies with Part 15 of the FCC Rules. Operation of this device is subject to the following two conditions: (1) This device may not cause harmful interference, and (2) this device must accept any interference received, including interference that may cause undesired operation.

WARNING:

Modification of this device to receive cellular radio-telephone service signals is prohibited under FCC rules and Federal Law.

Changes or modifications to this unit not expressly approved by the party responsible for compliance could void the user's authority to operate the equipment.

WARNING

1. Batteries (battery pack or batteries installed) shall not be exposed to excessive heat such as sunshine, fire or the like.
2. Excessive sound pressure from the earphones and headphones can cause hearing loss.

TROUBLESHOOTING

NO SOUND

- Ensure that the mains adapter is pushed fully into the power outlet and that its cable is properly connected to the DC IN 8V connector on the transmitter.
- Ensure that the receiver headphones On/Off switch is switched to the On.
- The headphones battery charge level may be too low. Recharge the batteries or replace them with fully charged batteries.
- Ensure that your TV set, Hi-Fi system or audio component is switched ON and set to a channel that broadcasts an audio signal.
- Use the receiver headphones volume control to increase the sound level when use as a cordless headphones.
- The connected audio/video equipment may not be in playback mode. Start playback on by the equipment.
- The receiver headphones output level is set too low. Adjust the volume to a suitable level.

DISTORTION

- If distortion appears, press the "Auto Scan" again.
- Use the channel selector to change the transmitter's transmission frequency. Then you will need to adjust the tuning control on the headphones.
- The receiver headphones battery charge level may be too low. Recharge the batteries or replace them with fully charged batteries.
- Ensure that the volume knob setting is correct.
- The headphones may be too far away from the transmitter. Move closer to it.
- The audio signal input level is too low. Increase the volume level of the audio source.

FCC INFORMATION

This device complies with Part 15 of the FCC Rules. Operation is subject to the following two conditions:

1. This device may not cause harmful interference, and 2. This device must accept any interference received, including interference that may cause undesired operation.

Note: This equipment has been tested and found to comply with the limits for a Class B digital device, pursuant to part 15 of the FCC Rules. These limits are designed to provide reasonable protection against harmful interference in a residential installation. This equipment generates, uses and can radiate radio frequency energy and, if not installed and used in accordance with the instructions, may cause harmful interference to radio communications. However, there is no guarantee that interference will not occur in a particular installation. If this equipment does cause harmful interference to radio or television reception, which can be determined by turning the equipment off and on, the user is encouraged to try to correct the interference by one or more of the following measures:

- Reorient or relocate the receiving antenna.
- Increase the separation between the equipment and receiver.
- Connect the equipment into an outlet on a circuit different from that to which the receiver is connected.
- Consult the dealer or an experienced radio/TV technician for help.

Caution: Any changes or modifications not expressly approved by the party responsible for compliance could void the user's authority to operate this equipment.