

# WIRELESS STEREO PANEL SPEAKER SYSTEM

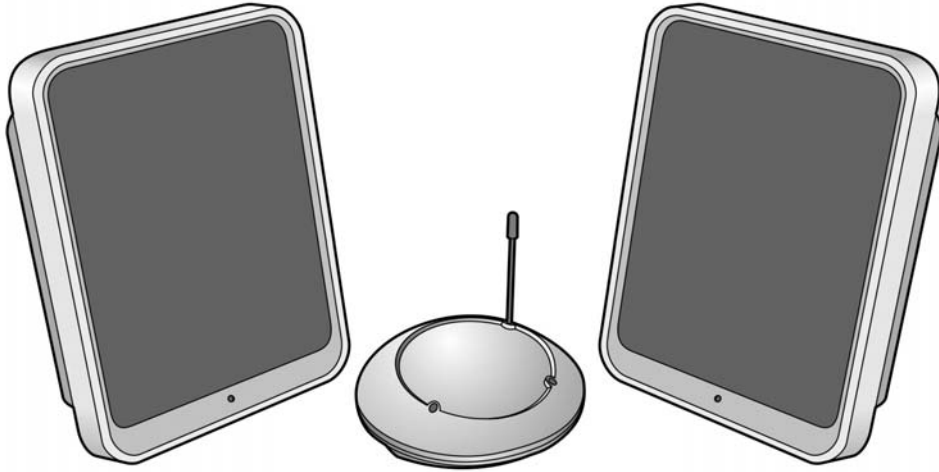

**ARKON  
SP2690**

**Owner's Manual**  
(Preliminary)

## **INTRODUCTION**

The 900 MHz stereo wireless speaker system uses latest wireless technology that enables you to enjoy music and TV sound anywhere inside or outside your home. You can simply connect the system to any audio source such as Radio, TV, VCR, Hi-Fi and CD/MP3/VCD/DVD player. Without complicated wiring and installation with your Audio/Video equipments and rear channel amplifier, the system enables you to enjoy thrilling, lifelike sound stereo in minutes.

## **FEATURES**

1. 900 MHz RF technology panel-like speaker system.
2. Phase Lock Loop (PLL) technology on transmitter.
3. RF technology lets you roam freely throughout your house.
4. Operating distance up to 50 Meters.
5. No line of sight limitation.
6. Virtually interference free stereo quality.
7. ALC and auto ON/OFF control.
8. Auto tuning function.
9. Bass boost function

## INSTALLATION

### TRANSMITTER

1. Insert the antenna tube into the antenna wire.

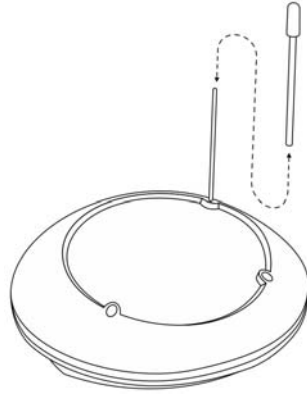

2. Connect the supplied AC power adaptor to an electrical wall outlet.
3. Plug the AC power adaptor in the DC jack located on the rear of the transmitter.

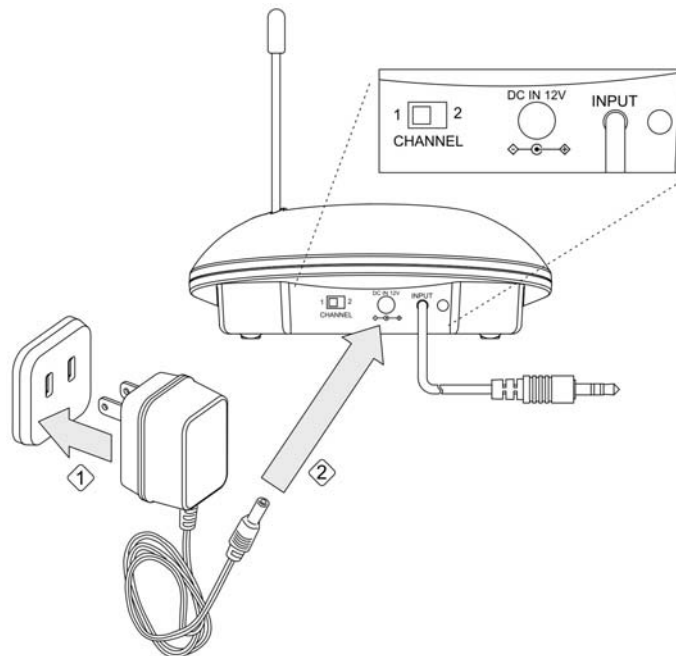

- The rear of the transmitter has one audio cord that can be connected to audio output jack of TV, Monitor, VCR, Radio recorder, CD/MP3/VCD/DVD players or to headphone/earphone jack with the connector provided.

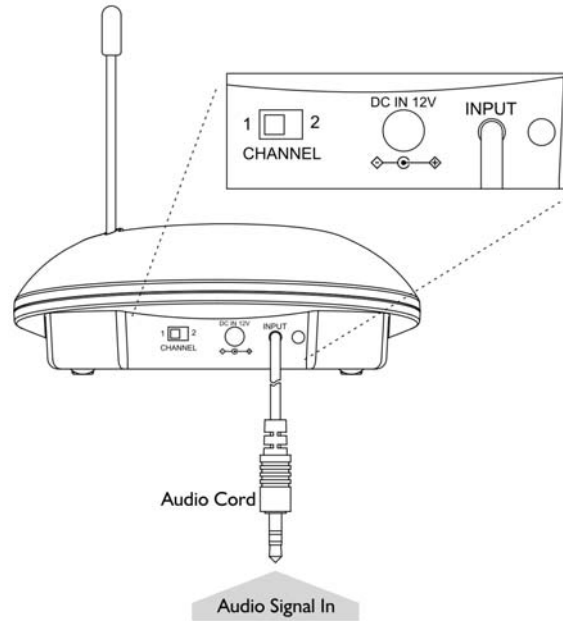

Plug the adaptor in the AC source and connect the audio plug to the audio source. As soon as the transmitter is receiving the audio signal, it will automatically switch on and the red LED will illuminate

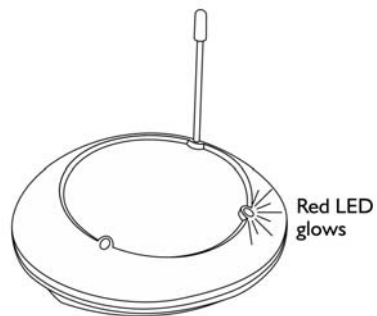

## SPEAKER RECEIVER

1. Insert 6 pieces 'AA' size ALKALINE battery into the battery compartment with correct polarity at the rear of the speaker or connect the 12V power adaptor to the DC input jack on the rear of each speaker, then plug it to the wall AC outlet.

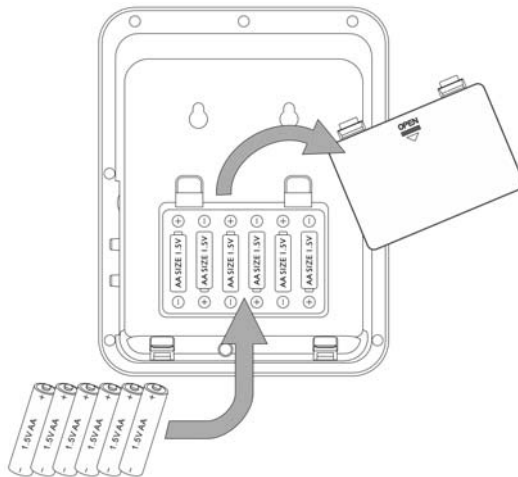

2. Switch on the speaker by turning up the VOLUME ON/OFF knob towards ON direction. The POWER/STEREO LED will light up. Switch off the speaker by turning down the VOLUME ON/OFF knob towards OFF direction until a "click" sound is heard.

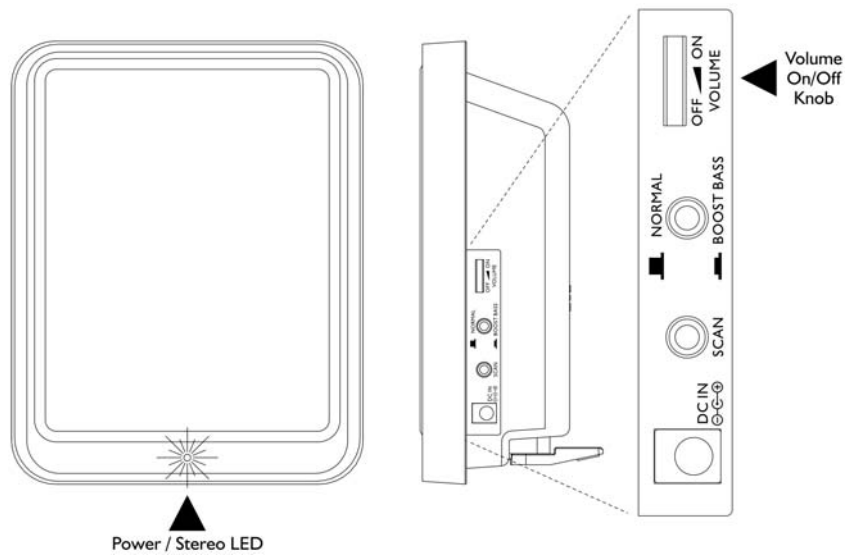

## OPERATION

1. Turn on the audio source (TV or audio component) to which the transmitter is connected with.  
The LED on transmitter will light up.

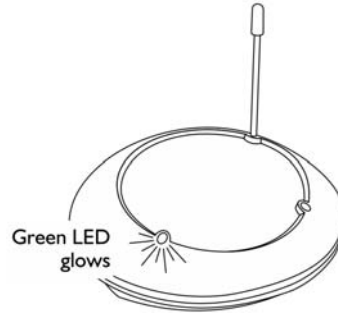

2. Select the channel 1 or 2 of the transmitter for best performance in your location.

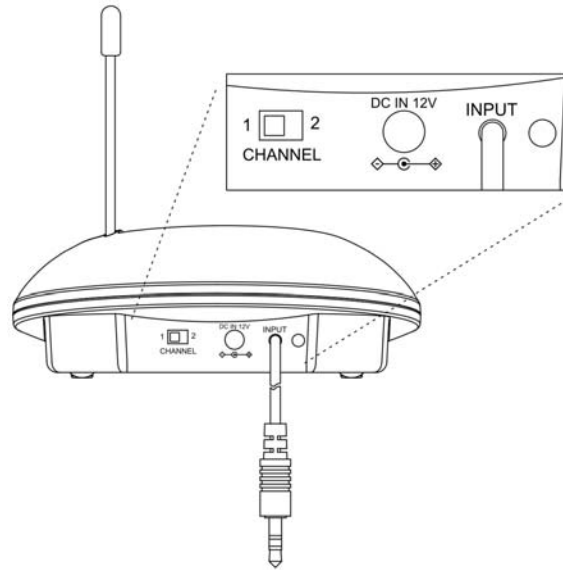

3. Turn on the ON/OFF VOLUME knob on the speaker and adjust the volume to the desired listening level.
4. Push the "SCAN" auto-tuning button to get the best tuning reception in the speakers.

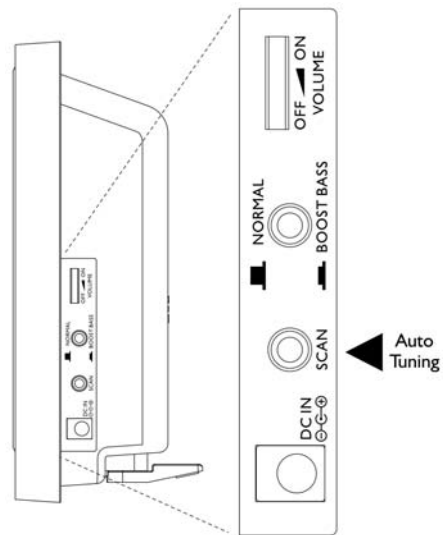

When the button is pressed, frequency tuning starts automatically and it stops when a signal is detected. The POWER/STEREO LED will change from red to green.

- A). Keep a distance of the speaker up to 7 meters apart from transmitter, and then press "SCAN" auto-tuning button for best tuning reception.
  - B) Whenever you find frequency jam, move your channel switch from one channel to the other channel (there are two channels for selection) on the transmitter, and then press the "SCAN" auto-tuning button again.
5. The BOOST BASS button can be used to enhance the bass sound depending on your own music preferences. Turn bass/boost effect ON simply by pressing the button down, and pressing it once again to OFF.

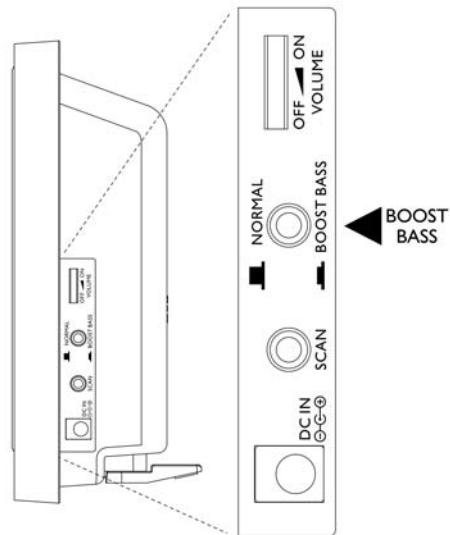

**Note**

You should now be able to place the speakers freely from room to room without disruption. If disruption should occur (signal breaks up), press the speaker's "SCAN" auto-tuning button to maximize best reception.

If you hear interference from other components, switch the channel control of transmitter, and then move the speakers to other free location. You can re-adjust the tuning control by moving it either channel 1 or, 2 of the transmitter, then pressing "SCAN" auto-tuning button for best reception.

When transmitting / receiving over long distances, the signal from the system will become weaker.



### **Switching off**

1. Turn the VOLUME ON/OFF knob until the click sound is heard to turn off the speaker and the LED light goes off
2. For protection of the transmitter and power saving, the transmitter will cut off automatically if there is no/weak operation input signal from audio source for 4 minutes.  
  
In other words, if the signal comes back, the transmitter will work again automatically.

### **TROUBLE SHOOTING**

#### **NO SOUND**

- Ensure the AC adaptor is fully inserted into the AC outlet and the power connection input on the transmitter.
- Ensure the speaker is switch ON.
- Speaker's battery capacity is too low, replace with new batteries or connect the AC adaptors to the speakers.
- Ensure the TV or audio component is ON.
- The connected audio / video equipment is not playing. Start playing the equipment.
- The volume of speaker is too low, adjust the volume to an appropriate level.

#### **DISTORTED**

- Press the "SCAN" button on the speakers until matching the frequency of the transmitter.
- Change the position of the channel selector on the transmitter. You must then press the SCAN button on the speaker.
- Battery capacity is too low. Replace with the new battery.
- Ensure the volume level of speakers is adjusted properly.
- The speaker is too far from transmitter, move closer.
- The input level of the audio signal is too low. Turn up the volume of the audio source equipment.

## SPECIFICATIONS

Transmission Mode	:	UHF stereo
Carrier Frequency	:	900 MHz
Operation Voltage	:	Transmitter, DC 12V 200mA Speaker, 6 X 'AA' size Alkaline batteries or DC 12V 600mA adaptor
Frequency Response	:	20Mz - 13KHz
Distortion	:	1.5%
S/N Ratio	:	50dB
Channel Separation	:	30dB
Operation Distance	:	Up to 50M (Open Area)

### Warning :

Changes or modifications to this unit not expressly approved by the party responsible for compliance could void the user's authority to operate the equipment. Operation is subject to the following two conditions: (1) this device may not cause interference, and (2) this device must accept any interference, including interference that may cause undesired operation of the device.

The device must be used accompany with the provided AC/DC adapter.

The provided AC/DC adapter shall always remain readily operable.

Please use the device in normal indoor environment.

The ventilation should not be impeded by covering the ventilation openings with items such as newspapers, table-cloths, curtains, etc...

This device shall not be exposed to dripping or splashing. No objects filled with liquids, such as vases, shall be placed on this device.