

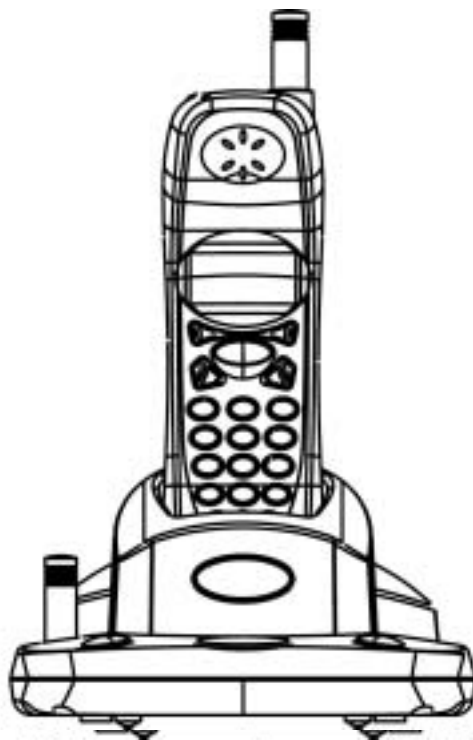

BELL[®] Phones
BY NORTHWESTERN BELL PHONES

Excursion[®] 35850



Congratulations on your selection of the Model: 35850 model from Northwestern Bell Phones. This quality 5.8GHz digital cordless telephone with Caller ID on Call Waiting, like all Genuine BELL[®] products, has been designed to give you many years of continuous service and represents the best value for your money. This phone is built on the state-of-the-art Frequency Hopping Digital Spread Spectrum radio communication technology for high quality voice communication and high level of conversation privacy. It requires little maintenance and is easy to setup and operate.

IMPORTANT SERVICE INFORMATION

Read this manual before attempting to setup or use this instrument. It contains important information regarding safe installation and use. Keep this manual for future reference. Also save the carton, packing and proof of purchase to simplify and accelerate any needed action. If you need assistance or service, call (800) 888-8990 between 8:00 a.m. and 4:30 p.m. Pacific Standard Time, Monday through Friday. You can also visit our web site at: <http://www.nwbphones.com> for technical support and information on our other products.



WARNING

To prevent fire or shock hazard, do not expose this product to rain or any type of excess moisture. If accidentally dropped into water, the adapter should immediately be unplugged from the wall along with the telephone line cord.



CAUTION

To maintain compliance with the FCC's RF exposure, place the base unit at least 20cm from nearby persons.



THIS SYMBOL IS INTENDED TO ALERT THE USER OF THE PRESENCE OF IMPORTANT OPERATING AND MAINTENANCE (SERVICING) INSTRUCTIONS IN THE OWNER'S MANUAL.

CARTON CONTENTS



HANDSET x2



BASE UNIT



EXTRA BASE

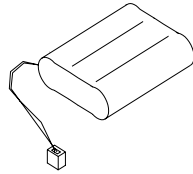

BELT CLIP x2
Ni-Mh BATTERY PACK x2



RECHARGEABLE
BRACKET



WALL MOUNT

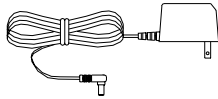

ADAPTER
(DC9V, 700mA)

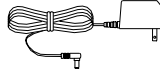

ADAPTER
(DC9V, 300mA)
(already attached cradle)

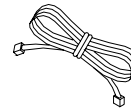

TELEPHONE
LINE CORD

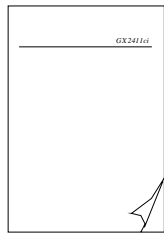

USER'S MANUAL

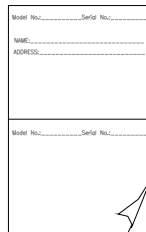

WARRANTY CARD



ACCESSORY ORDER FORM



SAVE THESE INSTRUCTIONS

IMPORTANT SAFETY INSTRUCTIONS

When using your telephone equipment, basic safety precautions should always be followed to reduce the risk of fire, electric shock, and injury to persons, including the following:

1. Read and understand all instructions.
2. Keep base unit at least 20cm distance apart from a person.
3. Follow all warnings and instructions marked on the product.
4. Unplug this product from the wall outlet before cleaning. Do not use liquid cleaners or aerosol cleaners. Use a damp cloth for cleaning.
5. Do not use this product near water, for example, near a bathtub, washbowl, kitchen sink, laundry tub, in a wet basement or near a swimming pool.
6. Do not place this product on an unstable cart, stand, or table. The product may fall, causing serious damage to the product.
7. Slots and openings in the cabinet at the back or bottom are provided for ventilation, to protect it from overheating. These openings should never be blocked or covered. The openings should never be blocked by placing the product on the bed, sofa, rug, or other similar surface. This product should never be placed near or over a radiator or heat register. This product should not be placed in a built-in installation unless proper ventilation is provided.
8. This product should be operated only from the type of power source indicated on the marking label. If you are not sure of the type of power supply to your home, consult your dealer or local power company.
9. Do not allow anything to rest on the power cord. Do not locate this product where the cord will be abused by persons walking on it.
10. Do not overload wall outlets and extension cords as this can result in the risk of fire or electric shock.
11. Never push objects of any kind into this product through cabinet slots as they may touch dangerous voltage points or short out parts that could result in a risk of fire or electric shock. Never spill liquid of any kind on the product.
12. To reduce the risk of electric shock, do not disassemble this product, but take it to a qualified service contractor when some service or repair work is required. Opening or removing covers may expose you to dangerous voltages or other risks. Incorrect reassembly can cause electric shock when the appliance is subsequently used.
13. Unplug this product from the wall outlet and refer servicing to qualified service personnel under the following conditions:
 - A. When the power supply cord or plug is damaged or frayed.
 - B. If liquid has been spilled into the product.
 - C. If the product has been exposed to rain or water.
 - D. If the product does not operate normally by following the operating instructions. Adjust only those controls that are covered by the operating instructions. Improper adjustments of other controls may result in damage and will often require extensive work by a qualified technician to restore the product to normal operation.
 - E. If the product has been dropped or the cabinet has been damaged.
 - F. If the product exhibits a distinctive change in performance.
14. Avoid using a telephone (other than a cordless type) during an electrical storm. There maybe a remote risk of electric shock from lightning.
14. Do not use the telephone to report a gas leak in the vicinity of the leak.

SAVE THESE INSTRUCTIONS



BATTERY SAFETY INSTRUCTIONS

CAUTION:

To reduce the risk of fire or injury to persons, read and follow these instructions:

1. Use only the following type and size of handset battery pack:
Cordless Telephone Battery Pack
DC3.6V, 850mAh, Ni-MH Battery Pack
2. Do not dispose of the battery in a fire. The cell may explode. Check with local codes for possible special disposal instructions.
3. Do not open or mutilate the battery. Released electrolyte is corrosive and may cause damage to the eyes or skin. It may be toxic if swallowed.
4. Exercise care in handling the battery in order not to short the battery with conducting material such as rings, bracelets and keys. The battery or conductor may overheat and cause burns.
5. Recharge only the battery provided with or identified for use with this product. The battery may leak corrosive electrolyte or explode if it is not the correct type.
6. Do not attempt to rejuvenate the battery provided with or identified for use with this product by heating them. Sudden release of the battery electrolyte may occur causing burns or irritation to eyes or skin.
7. When inserting the batteries into this product, the proper polarity or direction must be observed. Reverse insertion of batteries can cause charging that may result in leakage or explosion.
8. Remove the batteries from this product if the product will not be used for a long period of time (several months or more) since during this time the battery could leak in the product.
9. Discard "dead" batteries as soon as possible since "dead" batteries are more likely to leak in a product.
10. Do not store this product, or the battery provided with or identified for use with this product, in high-temperature areas. Batteries that are stored in a freezer or refrigerator for the purpose of extending shelf life should be stabilized at room temperature prior to use after cold storage.
11. Disconnect telephone lines before installing batteries.

SAVE THESE INSTRUCTIONS



INSTALLATION PRECAUTIONS

1. Never install telephone wiring during a lightning storm.
2. Never install telephone jacks in wet locations unless the jack is specifically designed for wet locations.
3. Never touch uninsulated telephone wires or terminals unless the telephone line has been disconnected at the network interface.
4. Use caution when installing or modifying telephone lines.



FCC NOTICE

The FCC requires that you be advised of certain requirements involving the use of this telephone.

1. This telephone is Hearing Aid Compatible.
2. On the bottom of this equipment is a label that contains, among other information, a product identifier in the form US:AAAEQ##TXXXX. You must, upon request, provide this information to your telephone company. The digits represented by ## in the product identifier indicate the Ringer Equivalency Number (REN) for this equipment. The REN is useful in determining the number of devices you may connect to your telephone line and still have all of these devices ring when your telephone number is called. In most (but not all) areas, the sum of the RENs of all devices connected to one line should not exceed 5. To be certain of the number of devices you may connect to your line as determined by the REN, contact your local telephone company.
3. This equipment complies with 47C FR Part 68 of the FCC rules. On the bottom of this equipment is a label that contains, among other information, the FCC registration number and Ringer Equivalence Number (REN) for this equipment. If requested, provide this information to your telephone company.
4. The REN is useful to determine the quantity of devices you may connect to your telephone line and still have all of those devices ring when your number is called. In most, but not all areas, the sum of the RENs of all devices should not exceed five (5.0). To be certain of the number of devices that you may connect to your line, as determined by the REN, you should call your local telephone company to determine the maximum REN for your calling area.
5. To maintain compliance with the FCC's RF exposure guidelines, place the base unit at least 20cm from nearby persons.
6. If your telephone causes harm to the telephone network, the telephone company may discontinue your service temporarily. If possible, they will notify you in advance. But if advance notice is not practical, you will be notified as soon as possible. You will be advised of your right to file a complaint with the FCC.
7. Your telephone company may make changes to its facilities, equipment, operations or procedures that could affect the proper operation of your equipment. If they do, you will be given advance notice so as to give you an opportunity to maintain uninterrupted service.
8. If you experience trouble with the telephone, please contact VTC Service & Manufacturing Co., Inc. at (800) 888-8990 or write to: VTC Customer Service, 16988 Gale Ave., City of Industry, CA 91745 for repair/warranty information. The telephone company may ask you to disconnect this equipment from the network until the problem has been corrected or you are sure that the equipment is not malfunctioning.
9. This equipment may not be used on coin service provided by the telephone company. Connection to party line service is subject to state tariffs. (Contact your state public utility commission or corporation commission for information).
10. **WARNING:** Changes or modifications to this unit not expressly approved by the party responsible for compliance could void the user's authority to operate the equipment.
NOTE: This equipment has been tested and found, complies with the limits for a class B digital device, pursuant to Part 15 of the FCC Rules. These limits are designed to provide reasonable protection against harmful interference in residential installation. This equipment generates, uses and can radiate radio frequency energy. If not installed and used in accordance with the instruction, may cause harmful interference to radio communications. However, there is no guarantee that interference will not occur in a particular installation. If this equipment does cause harmful interference to radio or television reception, which can be determined by turning the equipment off and on, the user is encouraged to try to correct the interference by one or more of the following measure:
 - Increase the separation between the equipment and receiver.
 - Connect the equipment into an outlet on a circuit different from that to which the receiver needed.
 - Consult the dealer of an experienced radio / TV technician for help.
12. USOC jack type is RJ11C and the compatible jack is Part 68 compliance.
13. If your home has specially wired alarm equipment connected to the telephone line, ensure the installation of this cordless phone does not disable your alarm equipment. If you have questions

TABLE OF CONTENTS

IMPORTANT SERVICE INFORMATION	1
CARTON CONTENTS	2
IMPORTANT SAFETY INSTRUCTIONS	3
BATTERY SAFETY INSTRUCTIONS	4
FCC / IC NOTICE	5
DESCRIPTION	7
MOUNTING POSITION	8
BELT CLIP INSTRUCTION	9
CONNECTING THE HEADSET	10
POWER INSTALLATION	10
INITIAL SETUP	11
PHONE SETUP OPEATION	
MENU LANGUAGE.....	11
RINGER VOLUME.....	12
RINGER TONE.....	12
AREA CODE.....	12
REGISTERING THE HANDSET.....	12
DEREGISTERING THE HANDSET.....	12
TONE/PULSE.....	13
AUTO ANSWER ON/OFF.....	13
EDIT USER NAME.....	13
LOAD DEFAULT.....	13
TELEPHONE OPERATION	
TO PLACE A CALL.....	13
TO RECEIVE A CALL.....	14
LAST NUMBER REDIAL.....	14
PAGING FUNCTION.....	14
RING ON INTERCOM.....	14
QUICK TRANSFER CALL TO OTHER HEADSET.....	14
TRANSFER CALL AFTER INTERCOM.....	15
CONFERENCE WITH LINE.....	15
SAVING IN THE PHONEBOOK.....	15
TELEPHONE KEYPAD CHARACTERS.....	15
PHONEBOOK	16
MIXED MODE DIALING.....	16
PAUSE/FLASH FUNCTION.....	16
FLASH FUNCTION.....	16
OUT OF RANGE WARNING.....	17
LOW BATTERY WARNING.....	17
CALLER ID OPERATION	
INTRODUCTION FO CALLER ID ON CALL WAITING.....	17
RECEIVING NEW CALL.....	18
VIEWING THE CALLER ID LIST.....	18
CALLER ID DISPLAY.....	18
CALL WAITING.....	19
MESSAGE WAITING.....	19
PLACING A CALL FROM THE CALLER LIST.....	20
SAVING THE NAME AND NUMBER FROM THE CALLER LIST INTO THE PHONEBOOK.....	20
SELECTIVE DELETING IN THE CALLER LIST.....	20
DELETING ALL RECORDS IN THE CALLER LIST.....	20
IMPROVING CORDLESS RECEPTION	21
MAINTENANCE	21
TROUBLESHOOTING	21
TECHNICAL INFORMATION	23

DESCRIPTION

CONTROLS' LOCATION AND FUNCTION

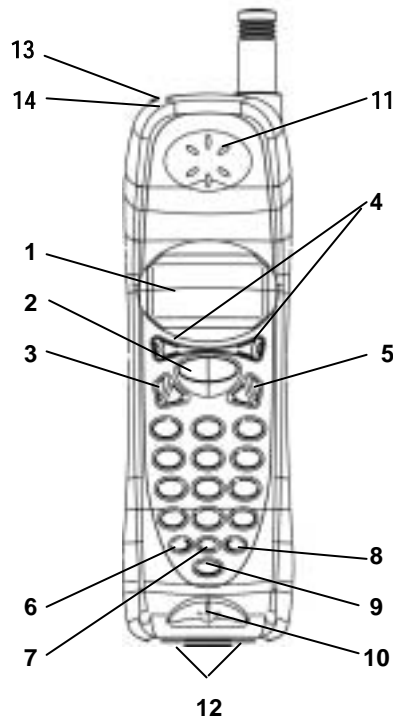

(Figure 1)

HANDSET CONTROLS

1. **LCD Display:** Shows call information, phone status, prompts and Phonebook items.
2. **TALK Button:** Press this button to answer an incoming call, place a call or end a call.
3. **INT/Format Button:** Press this button to page other handset or change CID number format on screen.
4. **Up/Down Button:** Press this buttons for menu/CID log/phonebook navigation, change receiver volume, delete records or delete characters.
5. **Menu/Hold Button:** Press this button to access phone setup options menu or hold the line.
6. **Mute/Delete:** Press this button to temporarily disable the microphone during talk/intercom/conference mode or to delete records/characters.
7. **Redial/Pause:** Press this button to redial the last number you have dialed, or to insert pause while dialing.
8. **Mem/Back:** Press this button to go into phonebook mode or to go back to previous menu during menu mode.
9. **Flash:** Press this button to send a time line break to phone line to access custom calling features such as Call Waiting or three-way calling provided by your local phone company.
10. **Microphone:** Used for speaking with callers.
11. **Receiver:** Allows you to hear calls.
12. **Charge Contacts:** Used for charging the handset battery.
13. **Headset Jack:** A jack located on the top of the handset used for connecting your headset to enjoy a hands-free communication.
14. **VMWI/Talk LED Indicator:** Red LED blinks when you have new message(s) and turn on steadily for talk mode.

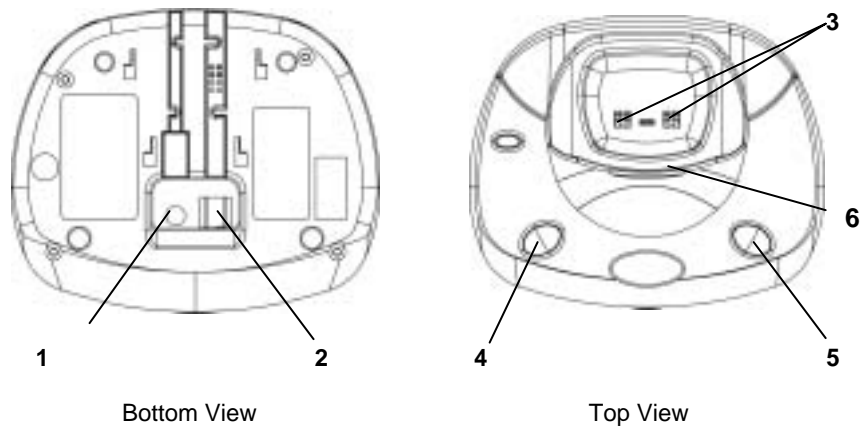

BASE UNIT CONTROLS

1. **9VDC Adapter Jack:** A jack located on the bottom of the base unit used for connecting the adapter to the base unit.
2. **TEL LINE Jack:** Accepts line cord to make connection with modular type telephone outlet.
3. **Charge Terminals:** Used for charging the handset battery.
4. **PROG Button:** Used when you are registering a new handset to the base.
5. **Page Button:** Allows you to locate the handset when it is not on the base.
6. **CHARGE/LINE-IN-USE LED Indicator:** Lights up steadily when the handset is being charged on the base or the phone is in talk mode. It will turn off when the handset is removed from its cradle and not in use.



EXTRA BASE UNIT CONTROLS

1. **9VDC Adapter Connector:** A jack located on the bottom of the base unit used for connecting the adapter to the base unit.
2. **CHARGE/LINE-IN-USE LED Indicator:** Lights up steadily when the handset is being charged on the base or the phone is in talk mode. It will turn off when the handset is removed from its cradle and not in use.
3. **Charge Terminals:** Used for charging the handset battery.

MOUNTING POSITION

DESKTOP USE:

Connect the telephone line cord to the TEL LINE jack on the bottom of the base unit and connect the opposite end to the telephone modular jack.



(Figure 3)

WALL USE :

A. WITH A MODULAR WALL JACK

1. Install the wall mount bracket at the position as shown in Figure 4.
2. Connect the telephone line cord to the TEL LINE jack on bottom of the base unit.
3. Connect the opposite end of the telephone line cord to the modular wall jack.
4. Align the wall mounting slots with the studs located on the modular wall plate and slide the base down to lock in place.

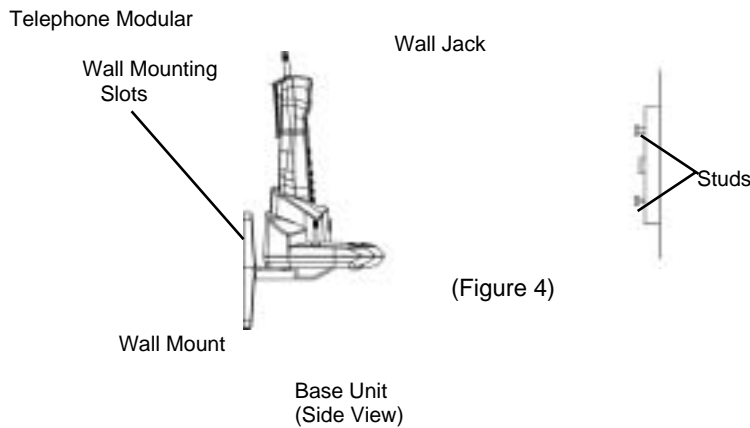

(Figure 4)

NOTE: If you do not have a standard modular wall jack, find a qualified technician to mount one on the wall.

B. WALL MOUNTING (No Standard Wall Jack)

1. Drill two holes with a vertical distance between the two marked positions of $3 \frac{15}{16}$ " (100 mm) as shown in Figure 5.
2. Drive a screw into each of the holes. Tighten them to the end of the screw line, only leaving the smooth part of the screw head outside the wall.
3. Hang the unit onto the screws, then slide it down firmly to fasten the base securely.

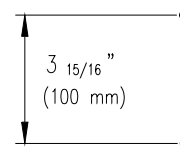

(Figure 5)

BELT CLIP INSTRUCTION

Remove the belt clip cover and clamp the belt clip to the back of the handset as shown in Figure 6.

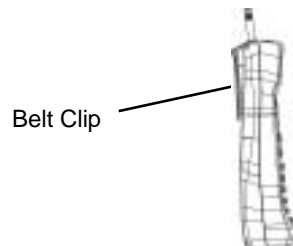

(Figure 6)

CONNECTING THE HEADSET

For hands free conversation, a headset (not included) is connected to the headset jack as shown in Figure 7. The handset receiver and microphone are disabled when the headset is connected.

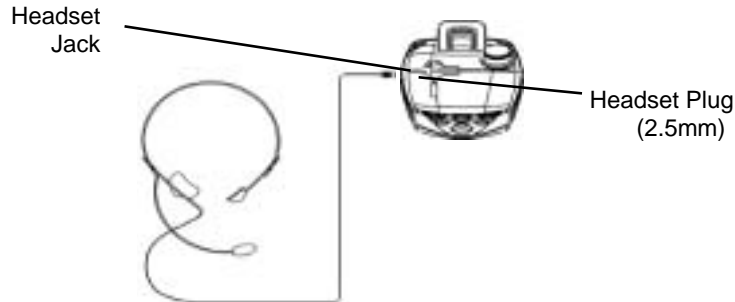

(Figure 7)

Press the TALK button to answer or place a call using the headset. Refer to the manufacturer's headset manual for more details.

You can purchase a suitable headset through service center or retailer shop. For servicing or replacement, please contact us for suitable headset

POWER INSTALLATION

BASE UNIT POWER CONNECTION



CAUTION:

You must use a Class 2 Power Source 9VDC 700mA. The plug must correctly fit the base unit's adapter jack.

1. Plug the adapter into a standard AC outlet.
2. Insert the small plug into the adapter jack on the bottom of the base as shown in Figure 8.

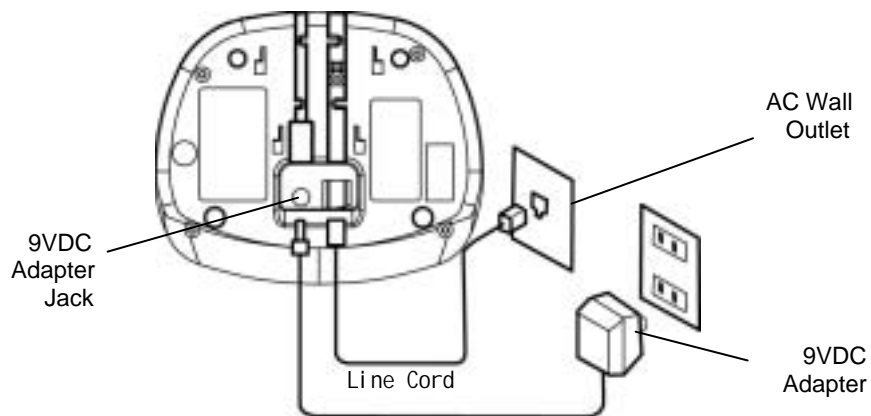

(Figure 8)

HANDSET BATTERY INSTALLATION



CAUTION:

Use only the Nickel Metal Hydride (Ni-MH) battery type included with this unit. Use of other battery types may cause injuries or damage. Ensure to insert the correct battery polarity as shown on the battery compartment during the battery installation.

1. Remove the battery compartment cover of the handset by pressing the top of the cover and sliding it down.
2. Connect the rechargeable Ni-MH battery as shown on Figure 9.

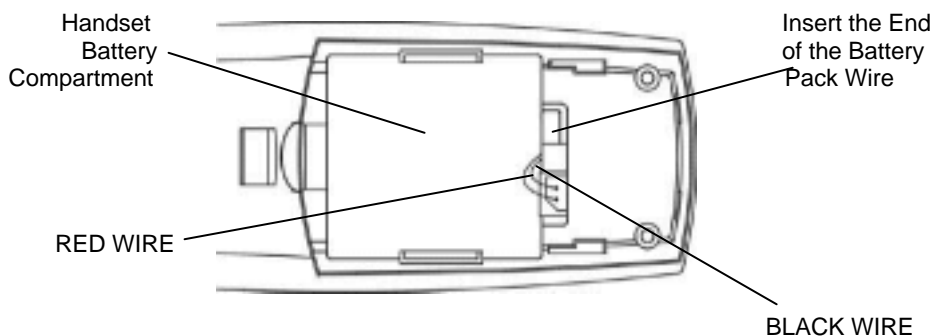

(Figure 9)

3. Insert the Ni-MH battery into the battery compartment of the handset.
4. Slide the battery compartment cover firmly in its closed position

INITIAL SETUP

Before you can use your cordless telephone, the handset must be charged for at least 12 hours. See charging instruction in the MAXIMIZING BATTERY LIFE section.

PHONE SETUP OPERATION

This unit contains the following special setup options:

MENU LANGUAGE
RINGER VOLUME
RINGER TONE
AREA CODE
REGISTRATION
DEREGISTRATION
TONE/PULSE
AUTO ANSWER
EDIT USERNAME
LOAD DEFAULT

MENU LANGUAGE

This telephone offers English, Spanish and French languages for your convenience.

1. Press MENU button.
2. Press MENU button.
3. Press UP or DOWN button to select the language you desire. English is the preset language.
4. Press MENU button to save the setting.
5. Press BACK button to go back to Standby mode.

RINGER VOLUME

This telephone offers 4 ringer options for user to select, they are level high, medium, low, off.

1. Press MENU button.
2. Press DOWN button.
3. Press MENU button.
4. Press UP or DOWN button to select the ringer volume level you desire.
5. Press MENU button to save the setting.
6. Press BACK button to go back to Standby mode.

NOTE: When ringer off is selected, all incoming call alert will be silent. You can also engage ringer off by one touch, press and hold the */Ringer off button during Standby mode, screen will prompt "RINGER OFF SELECTED!". You can also turn ringer off temporarily during ringing, press once the */Ringer off button to turn ringer silent.

RINGER TONE

This telephone offers 5 ringer tones for user to select.

1. Press MENU button.
2. Press DOWN button twice.
3. Press MENU button.
4. Press UP or DOWN button to select the ringer tone (1-5) you desire.
5. Press MENU button to save the setting.
6. Press BACK button to go back to Standby mode.

AREA CODE

This telephone allows you to input your local area code, during CID list review mode, the matched LAC case will the display hidden the LAC display in default mode.

1. Press MENU button
2. Press DOWN button 3 times.
3. Press MENU button.
4. Press 3 digits local area code.
5. Press MEUN button to save the setting.
6. Press BACK button to go back to Standby mode.

REGISTERING THE HANDSET

If your handset is not registered to a base unit, or you found problem when making communication with the base unit, you can register the handset from once more.

1. Press MENU button.
2. Press DOWN button 4 times.
3. Press MENU button to select registration option.
4. Press MENU button to select registration of own handset.
5. Press MENU button to confirm.
6. Press and hold base unit PROG button until handset beeps.
7. Press numeric keypad to input multi-tap alphanumeric characters. (max. 15characters)
8. Press MENU button to save the input.

DEREGISTERING THE HANDSET

If you want to move the handset to work with another 35850 base, you can deregister the handset from current base and then register to another base unit.

1. Press MENU button.
2. Press DOWN button 5 times.
3. Press MENU button to select deregistration option.
4. Press MENU button to select deregistration of own handset.
5. Press MENU button to confirm.
6. When deregistration is completed, handset will shows "REGISTER HANDSET?"

TONE/PULSE

This telephone allows you to dial digits using the tone signaling mode or the old pulse signaling mode.

1. Press MENU button.
2. Press DOWN button 6 times.
3. Press MENU button.
4. Press UP or DOWN button to select the dial signaling mode you desire.
5. Press MENU button to save the setting.
6. Press BACK button to go back to Standby mode.

AUTO ANSWER ON/OFF

This telephone allows you to enable or disable the handset to auto answer incoming call when is picked up from cradle during ringing.

1. Press MENU button.
2. Press DOWN button 7 times.
3. Press MENU button.
4. Press UP or DOWN button to select the auto answer enable/disable option you desire.
5. Press MENU button to save the setting.
6. Press BACK button to go back to Standby mode.

EDIT USERNAME

This telephone allows you to input your username which to be displayed during Standby mode and paging.

1. Press MENU button.
2. Press DOWN button 8 times.
3. Press MENU button.
4. Press numeric keypad to input multi-tap alphanumeric characters. (max. 15characters).
5. Press MENU button to save the input.
6. Press BACK button to go back to Standby mode.

LOAD DEFAULT

This telephone allows you to restore the phone setup options back to factory default. The Load Default action will cause Menu Language back to English, Ringer Volume back to Medium, Ringer Tone back to Tone 1, Area Code erased, Tone/Pulse mode back to Tone, Auto Answer back to Disable, ear piece volume back to Vol.1.

1. Press MENU button.
2. Press UP button.
3. Press MENU button.
4. Press UP button to select YES.
5. Press MENU button to confirm Load Default.
6. Press BACK button to go back to Standby mode.

TELEPHONE OPERATION

TO PLACE A CALL

1. Press the TALK button on the handset. The Call Timer starts to count. The base unit LINE IN USE LED indicator will light up.
2. Listen for a dial tone.
3. Dial the telephone number. The phone numbers appear on the LCD Display as you enter the number.
4. When finished with your call, press the TALK button or place the handset on the base cradle. The handset LED will turn off, the base LINE IN USE LED indicator will turn on to indicate charging.

NOTE: The call timer will start to count once you press the talk button. It will be shown up to 5 seconds after pressing TALK button.

TO RECEIVE A CALL

NOTE: If you are expecting incoming calls, the handset must be programmed to RING ON mode.

A. IF THE HANDSET IS ON THE BASE UNIT

1. When the phone rings, simply pick up the handset from the base cradle if the unit is set to auto-answer ON mode. If the unit is set to auto-answer OFF mode, press the TALK button. See page 13 to set auto-answer mode. The LCD Display will show "TALK".
2. Start your conversation.
3. To end your conversation, either press the TALK button or place the handset on the base unit. The handset LED indicator will turn off.

B. IF THE HANDSET IS OUT OF THE BASE UNIT

1. When the phone rings, press the TALK button on the handset. The LCD Display will show "TALK" and the handset and base unit LED will light up.
2. Start your conversation.
3. To end your conversation, either press the TALK button or place the handset on the base unit. The handset LED indicator will turn off.

LAST NUMBER REDIAL

A. AFTER HEARING A BUSY TONE WHEN PLACING A CALL

1. If you get a busy tone, press handset TALK button to hang up.
2. Press the handset TALK button again and listen for a dial tone.
3. Press the handset REDIAL button. This will automatically redial the last telephone number you called (Up to 32 digits).
4. When finished with your call, press the TALK button or place the handset on the base unit. The handset LED indicator will turn off.

B. WHEN THE HANDSET IS OFF THE BASE UNIT AND IN STANDBY MODE

1. Press the TALK button on the handset and listen for a dial tone.
2. Press the REDIAL button. This will automatically redial the last telephone number you called (Up to 32 digits).
3. When finished with your call, press the TALK button or place the handset on the base unit. The handset LED indicator will turn off.

PAGING FROM BASE TO HANDSET

1. Press the PAGE button on base.
2. All handset beeps and shows "PAGING FROM BASE". The page signal will last for 2 minutes.

PAGING AND INTERCOM WITH OTHER HANDSET

1. Press INT button on handset.
2. Press digit key 1~4 to input destination handset number.
3. Destination handset beeps, the page signal will last for 2 minutes.
4. If user presses the INT button on destination handset, it will bring both handsets into INTERCOM mode.
5. When finish with the intercom, press INT button on handset will end the intercom mode.

RING ON INTERCOM

1. During intercom mode, if there comes an incoming call, caller ID will display on the screen
2. Short beep alert will be heard.
3. Any user can press TALK key to end the intercom and take the call.
4. If the handset is replaced to cradle, the intercom will be ended and the handset starts ringing.

QUICK TRANSFER CALL TO OTHER HANDSET

1. During a call, the user can press the INT key followed by destination handset number (1~4).
2. Press TALK key to end and the call is quick transferred to the destination handset, it starts ringing and shows "TRANSFER FROM HANDSET 1".
3. If destination handset user does not answer the call within 30 sec, source handset will be ring back for 30 sec.

TRANSFER CALL AFTER INTERCOM

1. During a call, the user can press the INT key followed by destination handset number (1~4).
2. If destination handset user presses the INT key to answer the intercom request, intercom mode is setup and call is on hold.
3. After the intercom, source handset can press TALK button to end the intercom and the call is taken by the destination handset automatically.

CONFERENCE WITH LINE

1. During a call, the user can press the INT key followed by destination handset number (1~4).
2. If destination handset user presses the INT key to answer the intercom request, intercom mode is setup and call is on hold.
3. In intercom mode, source handset user can press CONF button to get the destination handset into the conference mode with the external line. After conference, any handset can quit the conference by pressing TALK button.

SAVING IN THE PHONEBOOK

1. Press the MEM button.
2. Press UP/DOWN button to select location, or enter 2 numeric digits to select location directly. (01~20)
3. Press MENU to confirm editing in the current location.
4. Use the TELEPHONE KEYPAD buttons (0-9) to enter the name. You can store up to 15 characters.
5. Press MENU button once.
6. Enter the telephone number using the TELEPHONE KEYPAD buttons (0-9). You can store up to 24 digits.
7. Press MENU button to save into current memory location and goes back to Standby mode.

NOTE: The above procedure will overwrite current location if it is not empty. If no active buttons are pressed for 60 seconds, the LCD Display will automatically return to STANDBY mode.

TELEPHONE KEYPAD CHARACTERS

The TELEPHONE KEYPAD buttons (0~9) are used to enter the characters when entering names. Press the appropriate KEYPAD button to get the following characters.

Keypad Button	Multi-tap Characters
1	Spc _ * !
2	A B C (
3	D E F)
4	G H I \$
5	J K L /
6	M N O ;
7	P Q R S
8	T U V ?
9	W X Y Z

Example: If you want to enter the character "C", press the "2" KEYPAD button, the first character displayed will be "A". Press the "2" button again within 1 second to display "B", and press again within 1 second to display the letter "C". To enter the next character, press the appropriate button. If, however, the next character is on the same button as the previous character, you will need to wait for 1 second until the cursor shifts. If you want to change any character, you can go backward by pressing DELETE button to erase character one by one.

VIEWING THE PHONEBOOK

This 20 memories Phonebook lets you store 20 records each of 15 character names and 24 digit number, it is a location dependent phonebook and you can scroll through the list by arrow keys.

1. Press the MEM button.
2. Press the UP or DOWN button to find the one you need, If number is more than 1 page, it will show 2 pages alternatively.

NOTE: To exit the Phonebook at anytime, press the BACK button.

EDITING NAME AND NUMBER IN THE PHONEBOOK

1. Press the MEM button.
2. Press the UP or DOWN button to find the one you want to edit.
3. Press MENU button to edit the name.
4. Use the TELEPHONE KEYPAD buttons (0-9) to re-enter the name. (up to 15 characters)
5. Press the MENU button once.
6. Use the TELEPHONE KEYPAD buttons (0-9) to re-enter the number. (up to 24 digits)
7. Press the MENU button to confirm and save the change.

IMPORTANT: It is not advisable to save a telephone number without the corresponding name in the Phonebook.

Note: When no active buttons are pressed for 60 seconds, the LCD Display will automatically return to STANDBY mode.

PLACING CALLS FROM THE PHONEBOOK

1. Press the MEM button.
2. Press the UP or DOWN button to find the one you want to call.
3. Press the TALK button to dial out the telephone number.
4. Start your conversation.
5. To end your conversation, either press the TALK button or place the handset on the base unit.

NOTE: Be sure to check that the line is not in use by another parallel phone.

DELETING A STORED NUMBER IN THE PHONEBOOK

1. Press the MEM button.
2. Press the UP or DOWN button to find the one you want to delete.
3. Press the DELETE button. The unit will ask you to delete the selected telephone number and the LCD Display will show "DELETE THIS?"
4. Press again the DELETE button to delete. The LCD Display will show "DELETED!" and returns to Standby mode.

MIXED MODE DIALING (Temporary Pulse to Tone Dialing)

1. If you only have pulse (rotary dialing) service in your area and want to access Tone services (Phone banking service, etc.), ensure that the signaling mode setting in the phone setup menu is set to Pulse mode.
2. Press the */TONE button once to switch from Pulse to Tone dialing temporarily. Pulse dialing mode resumes when the call is ended.

PAUSE FUNCTION

- In some cases, such as PBX or long distance service, a pause may be needed in the dialing sequence. Pressing the handset PAUSE button inserts a four-second delay between dialed numbers.

FLASH FUNCTION

- Used to access custom calling features such as Call Waiting or Three-Way Calling provided by your local phone company. Flash can also be used to restore a dial tone to make a new call.

OUT OF RANGE WARNING

- The handset and base unit communicate up to a certain maximum range. The distance can be affected by weather, power lines, or even other cordless telephones.
- If you far away from the base unit, the handset will show "OUT OF RANGE" on the LCD display to warn you that bit error rate is too high for proper communication between the handset and the base unit.
- When you hear no voice and see the "OUT OF RANGE" display, you should move closer to the base unit. Otherwise, the call will automatically cut off after 30 seconds.

LOW BATTERY WARNING

- When the handset battery voltage level is low, the handset LCD Display shows "BATTERY LOW!".
- Return the handset on the base cradle or charge cradle for charging.

CALLER ID OPERATION

IMPORTANT: Subscription to Caller ID on Call Waiting services from your local phone company is required for using the Caller ID on Call Waiting features of the 35850. Your new 35850 telephone gives you the ultimate in cordless telephone sound quality with the luxury of Caller ID on Call Waiting.

If this is your first cordless telephone, you will soon discover that your cordless is similar to regular telephones, except without the cord. If you have owned a cordless in the past, you will discover that the 35850 telephone is the most powerful and full-functioned Caller ID on Call Waiting cordless telephone on the market, some key features are:

- 40 name and number Caller ID on Call Waiting memory (Caller List)
- 20 name and number programmable memory (Phonebook)
- Hearing aid compatibility
- Frequency Hopping Digital Spread Spectrum radio communication technology

Unlike regular telephones, your cordless telephone does not work during power failures. We do not recommend you to use a cordless telephone as the only phone in your residence.

INTRODUCTION TO CALLER ID ON CALL WAITING

The 35850 Caller ID on Call Waiting devices allow you to take advantage of the Caller Identification delivery service offered by your local telephone company. For more information, you can refer to the following Question and Answer table:

QUESTIONS	ANSWERS
What is Caller ID?	Caller ID is a device that identifies the calling party before you answer a call. This device can be used to screen unwanted calls and eliminate harassment from annoying calls.
What is CID on Call Waiting?	CID on Call Waiting is a device that can also identifies that call waiting part before you answer a call.
How Does Caller ID on Call Waiting work?	When used with Caller ID on Call Waiting service, the Caller ID on Call Waiting device displays the name (if available) and the telephone number (if available) of the person calling before you answer your telephone.
Who provides Caller ID services?	Your local telephone company. However, not all local telephone companies provide Caller ID service. Please call you local phone company to confirm that the service is available before you install the device.

How Can I activate my Caller ID?	For your Caller ID unit to function, you must first arrange with your local telephone company to have Caller ID on Call Waiting service installed on your line. There is an extra charge added to your monthly telephone bill for this service. Before using this unit, please read this instruction manual carefully.
----------------------------------	--

RECEIVING NEW CALL

- When you receive a new call, the call information is stored under CALLER ID List. The "NEW" segment of LCD Display will turn on if there is unread new call(s) in the caller list.
- When you receive a call, the system displays the caller information sent by the telephone company, called a Call Record. The Call Record consists of the following information.
 - a. The caller's name (if available)
 - b. The caller's telephone number
 - c. The time and date of a call
 - d. A call record number

VIEWING THE CALLER ID LIST

In Standby mode, press UP/DOWN button to enter Caller ID list. If there is new call(s), the "new call 03" prompt will be displayed at first where "03" is indicating number of unread Caller ID record in the caller list.

Press UP or DOWN button to scroll to the next call. The DOWN button will go through the calls from the last call received to the first. The UP button will allow you to view the calls from the first call received to the last.

Press BACK button to finish review.

NOTE: If no active buttons are pressed for 60 seconds, the LCD Display will automatically return to STANDBY mode. If you press the UP/DOWN button within 60seconds after back to Standby mode, it will resume to the previous record in the Caller list, this will ease the "slow" user to go through the caller list without scrolling back to previous record by too many key strokes.

Caller ID display

12:35AM	11/30		CALL#07
123-845-3892			
JOHN SMITH			

LCD Display shows name and number, time and date of the call.

12:35AM	11/30		CALL#07
123-845-3892			

LCD Display shows number-only service.

12:35AM	11/30		CALL#07
UNKNOWN CALLER			

"UNKNOWN CALLER" will be displayed when Caller ID information is not available. This call was made from a telephone company that does not offer Caller ID services (including international calls).

12:35AM	11/30		CALL#07
BLOKED CALL			

"BLOKED CALL" will be shown when a call is received from a blocked number. For privacy reasons, some states allow callers the option to prevent their telephone data from being displayed on the other party's Caller ID display.

INCOMPLETE DATA			

Display shows when the Caller ID information was received incorrectly or only part of the data was received.

NOTE: When an incomplete data CID is received, none of the data from this call is saved in memory.

MESSAGE WAITING			

Display shows when a voice mail message has been received and is stored by message waiting service provided by the phone company.

12:35AM	11/30		CALL#07
123-845-3892			
JOHN SMITH			

Display shows when the incoming call ringing.

NO RECORD!			

This is displayed when UP/DOWN button is pressed and there is no Caller ID data stored.

CALL WAITING

When you subscribe to Call Waiting service from your local telephone Company, this telephone will display the name and number of the second caller while you are having a conversation.

When a second call comes in while you are having a conversation, you will hear a notification tone from the handset and volume is momentarily muted. The LCD will automatically shows the name and number of the second caller.

Press the FLASH button to answer the second caller. The first caller's name and number will be displayed.

When you have finished, press the FLASH button to continue with your conversation with the first caller.

MESSAGE WAITING

If you have subscribed to Voice Mail message service and if you have requested Visual Message Indication from your local telephone company, the MSG / TALK LED indicator will blink and the LCD will show "MESSAGE WAITING" when there is voice message(s) for you from your telephone company.

PLACING A CALL FROM THE CALLER LIST

Press the UP/DOWN button.

Press the UP button or DOWN button to select the call record you wish to call back.

If the number displayed is not correct (needing 7, 8, 10, 11, 12 digits), press the FORMAT button to select call number.

JOHN SMITH
555-555-1212

Press FORMAT button.

JOHN SMITH
555-1212

Press FORMAT button.

JOHN SMITH
15555551212

Press TALK button to dial out or press BACK button to cancel dialing.

To end your conversation, either press the TALK button or place the handset on the base unit.

SAVING THE NAME AND NUMBER FROM THE CALLER LIST INTO THE PHONEBOOK

1. Press the UP/DOWN button.
2. Press the UP or DOWN button to scroll to the call record you wish to store into the phonebook.
3. Press MENU button. The LCD Display shows "SELECT LOCATION".
4. Press 2 digits numeric key to select location (01-20 only)
5. Screen will back to Standby mode.

NOTE: If you press the FORMAT button to change the display format before saving to phonebook, the final displayed number on screen will be stored to the phonebook location.

SELECTIVE DELETING IN THE CALLER LIST

1. Press the UP/DOWN button.
2. Press the UP or DOWN button to scroll to the call record you wish to delete.
3. Press DELETE button. The LCD Display will show "DELETE RECORD?"
4. To delete the selected call record, press DELETE button again to confirm.
5. Screen will shows "DELETED!"

DELETING ALL RECORDS IN THE CALLER LIST

1. Press the UP/DOWN button.
2. Press the UP or DOWN button to scroll to the call record you wish to delete.
3. Press and hold DELETE button. The LCD Display will show "DELETE ALL?"
4. To delete the selected call record, press DELETE button again to confirm.
5. Screen will shows "NO RECORD!"

IMPROVING CORDLESS RECEPTION

Follow these guidelines to improve cordless sound quality:

- Select an area to install the 35850 where it is closest to the center of your home or office. This will improve the operating range of the unit.
- Keep the 35850 base unit away from electrical equipment. Radio Frequency Interference (RFI) is sometimes generated by these appliances, which can cause degradation in cordless reception.
- Keep the handset batteries charged as much as possible. Weak handset batteries can limit the range of cordless operation.

MAINTENANCE

1. Your phone should be situated away from heat sources such as radiators, heaters, stoves or any other appliance that produces heat.
2. Use a slightly damp cloth to clean the plastic cabinet. A mild soap will help to remove grease or oil. Never use polish, solvents, abrasives or strong detergents since these can damage the finish.

TROUBLESHOOTING

A. TELEPHONE UNIT TROUBLESHOOTING TABLE

Symptoms	Possible Solution / Cause
No dial tone	<ul style="list-style-type: none">• Check that the telephone line cord connectors at both ends are pushed in firmly until they click.• If you had a power failure or had unplugged the base unit, replace the handset on the base unit for two to five seconds to reset the system.
Does not ring	<ul style="list-style-type: none">• Check the ringer volume mode on the handset. Set to ringer hi/med/lo mode to enable the handset ringer.• Check that the telephone line cord connectors at both ends are pushed in firmly until they click.• You may have exceeded the Ringer Equivalence Number (REN) limit of how many phones can be connected to the same line. The REN total of all devices (printed on the bottom label of each unit) should not exceed five (5). Disconnect the appropriate units to lower the REN total.
No power on the handset unit	<ul style="list-style-type: none">• Check the Ni-MH battery pack for proper connection inside the battery compartment on the handset.• The handset rechargeable Ni-MH battery pack may need charging.
Does not charge	<ul style="list-style-type: none">• Check the Ni-MH battery pack for proper connection inside the battery compartment on the handset.• Make sure the charging contacts on both the base unit and the handset are in contact during charging.• The charging contacts and terminals may need cleaning with an alcohol-dampened swab.
Range is limited	<ul style="list-style-type: none">• Raise or reposition the antenna on the base.• Move the base unit so that it is centrally located in your residence or office and make sure that the base unit is not located near appliances.• The handset Ni-MH battery may be weak. Recharge the Ni-MH battery.• Refer to the section "Improving Cordless Reception".
Calls received flutters or fades	<ul style="list-style-type: none">• The handset rechargeable Ni-MH battery pack may need charging.
Interference on reception	<ul style="list-style-type: none">• Refer to the section "Improving Cordless Reception".

Excessive static	<ul style="list-style-type: none"> • Refer to the section "Improving Cordless Reception".
------------------	--

B. CALLER ID SYSTEM TROUBLESHOOTING TABLE

Symptoms	Possible Solution / Cause
The Caller ID panel is blank	<ul style="list-style-type: none"> • Check the power connection. • Check the telephone line cord connections. • Check the batteries for proper installation.
The Caller ID does not show the caller's name and / or phone number.	<ul style="list-style-type: none"> • The Caller ID unit will not function until you have Caller ID service provided by your local phone company. Call your local phone company to have Caller ID installed on your telephone line. • Check your telephone line connections. Make sure all connections are secure and connected. • If you pick up the phone <u>before</u> the second ring, the caller information <u>will not</u> be correctly received. If you have telephone answering device (TAD) connected with the unit, set the TAD to answer after two rings or more. • If it is a blocked call or an out-of-area call, the caller's name and / or phone number will not appear on the display. • If only the caller's phone number appears on the display, it may be a Single Data Message Format (SDMF) call, as opposed to a Multiple Data Message Format (MDMF) call. Please call your local phone company to see which service you have.
Random characters and / or "NO DATA" appear on the LCD display.	<ul style="list-style-type: none"> • On rare occasions, the Caller ID information sent by the telephone company may have an error in the transmission. This is not the fault of your Caller ID unit. It can only capture and store the data that was received.
Cannot get Call Waiting identification on the LCD panel.	<ul style="list-style-type: none"> • Subscription to Caller ID Call Waiting (CIDCW) is required from your local phone company for the CIDCW function to operate properly. Call you local phone company for details.

TECHNICAL INFORMATION

This cordless phone uses radio frequencies to allow mobility. There are certain difficulties in using radio frequencies with a cordless telephone. While these are normal, the following could affect the operation of your system.

NOISE: Electric pulse noise is present in most homes at one time or another. This noise is most intense during electrical storms. Certain kinds of electric equipment such as light dimmers, fluorescent bulbs, motors, and fans also generate noise pulses. Because radio frequencies are susceptible to these noise pulses, you may occasionally hear them in your handset. Generally, they are minor annoyances and should not be interpreted as defects in your system.

RANGE: Because radio frequencies are used, location of the base unit can affect operating range. Try several locations in your home or business and pick the one that gives you the clearest signal.

INTERFERENCE: Some electronic devices operate in and/or generate interference near the operating frequencies of your cordless telephone. While several protection circuits are used to prevent unwanted signals, there may be periods when these unwanted signals cause interference. If interference occurs frequently, it can be minimized or eliminated by lowering the height of your base antenna or by relocating the base unit. You can check for interference before selecting the final base unit location by plugging in the phone.



ADAPTER: Use Only Class 2 Power Source 9VDC 700mA.



BELL[®] Phones
BY NORTHWESTERN BELL PHONES

**Distributed Exclusively Worldwide by Unical
Enterprises, Inc., Industry, California USA**

35850/05111A-1

www.nwbphones.com