

EXAI8580 & DXAI8580 Series Cordless Phone User's Guide

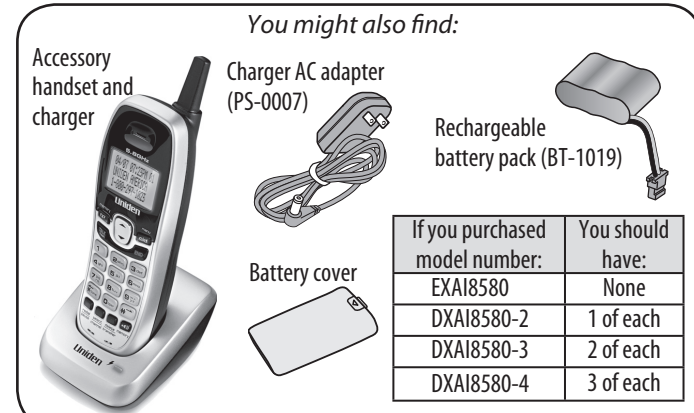
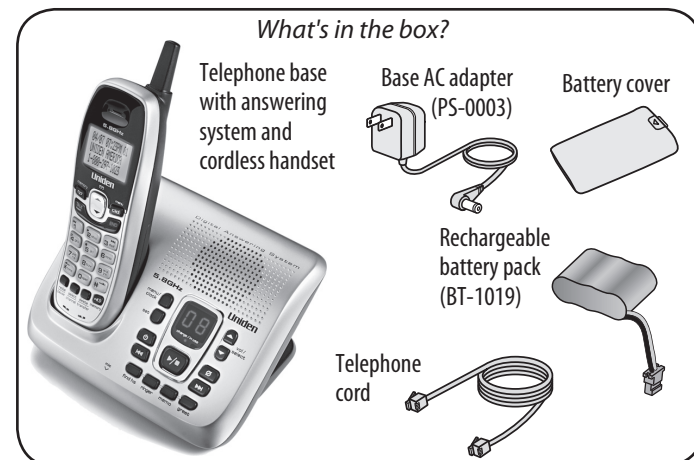

If any items are missing or damaged, contact our Customer Care Line immediately. Never use damaged products!

Need Help? Get answers 24/7 at our website: www.uniden.com.

If You...	Contact Uniden's...	Phone Number
have a question or problem	Customer Care Line*	817-858-2929 or 800-297-1023
need a part or accessory	Parts Department*	800-554-3988
need special assistance due to a disability	Accessibility Help Line	800-874-9314 (voice or TTY)

* During regular business hours, Central Standard Time. Visit our website for detailed business hours.

Important Safety Instructions!

When using your telephone equipment, always follow basic safety precautions to reduce the risk of fire, electric shock and injury to persons, including the following:

- ◆ This unit is NOT waterproof. DO NOT expose this unit to rain or moisture.
- ◆ Do not use this product near water, for example, near a bath tub, wash bowl, kitchen sink or laundry tub, in a wet basement or near a swimming pool.
- ◆ Avoid using a telephone (other than a cordless type) during an electrical storm. There may be a remote risk of electric shock from lightning.
- ◆ Do not use the telephone to report a gas leak in the vicinity of the leak.
- ◆ Use only the power cord and batteries indicated in this manual. Do not dispose of batteries in a fire. They may explode. Check with local codes for possible special disposal instructions.
- ◆ Do not place the handset in any charging cradle without the battery installed and the battery cover secured in place.

SAVE THESE INSTRUCTIONS!

Battery Information

- ◆ Fully charged, the battery should provide about 5 hours of talk time and about 6 days of standby time. For best results, return the handset to the cradle after each call to keep it fully charged.
- ◆ Keep an eye on the battery status icon. When the battery gets too low, the handset shows a low battery alert. If you hear a strange beep during a call, check the display: if you see the low battery alert, finish your conversation as quickly as possible and return the handset to the cradle. If the handset is in standby, none of the keys will operate.
- ◆ With normal use, the battery should last about one year. Replace the battery when the talk time becomes short even when the battery is charged. To buy a replacement battery, call the Parts Department listed on the front cover.

Rechargeable Nickel-Cadmium Battery Warning

CAUTION! Risk of explosion if battery is replaced by an incorrect type! Dispose of used batteries according to the instructions. Do not open or mutilate the battery. Disconnect the battery before shipping this product.

- ◆ This equipment contains a rechargeable nickel-cadmium (Ni-Cd) battery.
- ◆ Cadmium and Nickel are chemicals known to the State of California to cause cancer.
- ◆ Do not short-circuit the battery.
- ◆ The rechargeable Ni-Cd battery contained in this equipment may explode if disposed of in a fire.
- ◆ Do not charge the battery used in this equipment in any charger other than the one designed to charge this battery as specified in the owner's manual. Using another charger may damage the battery or cause it to explode.
- ◆ As part of our commitment to protecting our environment and conserving natural resources, Uniden voluntarily participates in an RBRC® industry program to collect and recycle used Ni-Cd batteries within the United States. Please call 1-800-8-BATTERY for information on Ni-Cd battery recycling in your area. (RBRC® is a registered trademark of the Rechargeable Battery Recycling Corporation.)

Rechargeable Batteries Must Be Recycled or Disposed of Properly. Uniden works to reduce lead content in PVC coated cords in our products & accessories.

Warning! The cords on this product and/or accessories contain lead, a chemical known to the State of California to cause birth defects or other reproductive harm. Wash hands after handling.

One-year Limited Warranty

Important: Evidence of original purchase is required for warranty service.

WARRANTOR: UNIDEN AMERICA CORPORATION ("Uniden") ELEMENTS OF WARRANTY: Uniden warrants, for one year, to the original retail owner, this Uniden Product to be free from defects in materials & craftsmanship with only the limitations or exclusions set out below.

WARRANTY DURATION: This warranty to the original user shall terminate & be of no further effect 12 months after the date of original retail sale. The warranty is invalid if the Product is (A) damaged or not maintained as reasonable or necessary, (B) modified, altered, or used as part of any conversion kits, subassemblies, or any configurations not sold by Uniden, (C) improperly installed, (D) serviced or repaired by someone other than an authorized Uniden service center for a defect or malfunction covered by this warranty, (E) used in any conjunction with equipment or parts or as part of any system not manufactured by Uniden, or (F) installed or programmed by anyone other than as detailed by the owner's manual for this product.

STATEMENT OF REMEDY: In the event that the product does not conform to this warranty at any time while this warranty is in effect, warrantor will either, at its option, repair or replace the defective unit & return it to you without charge for parts, service, or any other cost (except shipping & handling) incurred by warrantor or its representatives in connection with the performance of this warranty. Warrantor, at its option, may replace the unit with a new or refurbished unit. THE LIMITED WARRANTY SET FORTH ABOVE IS THE SOLE & ENTIRE WARRANTY PERTAINING TO THE PRODUCT & IS IN LIEU OF & EXCLUDES ALL OTHER WARRANTIES OF ANY NATURE WHATSOEVER, WHETHER EXPRESS, IMPLIED OR ARISING BY OPERATION OF LAW, INCLUDING, BUT NOT LIMITED TO ANY IMPLIED WARRANTIES OF MERCHANTABILITY OR FITNESS FOR A PARTICULAR PURPOSE. THIS WARRANTY DOES NOT COVER OR PROVIDE FOR THE REIMBURSEMENT OR PAYMENT OF INCIDENTAL OR CONSEQUENTIAL DAMAGES. Some states do not allow this exclusion or limitation of incidental or consequential damages so the above limitation or exclusion may not apply to you. LEGAL REMEDIES: This warranty gives you specific legal rights, & you may also have other rights which vary from state to state. This warranty is void outside the United States of America & Canada.

PROCEDURE FOR OBTAINING PERFORMANCE OF WARRANTY: If, after following the instructions in the owner's manual you are certain that the Product is defective, pack the Product carefully (preferably in its original packaging). Disconnect the battery from the Product & separately secure the battery in its own separate packaging within the shipping carton. The Product should include all parts & accessories originally packaged with the Product. Include evidence of original purchase & a note describing the defect that has caused you to return it. The Product should be shipped freight prepaid, by traceable means, to warrantor at:

Uniden America Service
4700 Amon Carter Blvd.
Fort Worth, TX 76155

◆ Uniden® is a registered trademark of Uniden America Corporation.
◆ The pictures in this manual are for example only. Your phone may not look exactly like the pictures.

◆ Call waiting, CID, & CIDCW are telephone line services. Your phone supports these services, but you have to arrange for them through your telephone provider. Contact your provider for details. May be covered under one or more of the following U.S. patents:
5,987,330 6,044,281 6,070,082 6,076,052 6,125,277 6,253,088 6,314,278 6,321,068 6,418,209 6,618,015 6,714,630 6,782,098 6,788,920 6,788,953 6,839,550 6,889,184 6,901,271 6,907,094 6,914,940 6,940,867 6,953,118 7,023,176 7,030,819 7,146,160 7,203,307 7,206,403 7,310,398
Other patents pending.

Connect the Battery

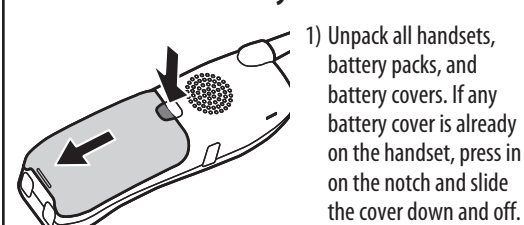

Installing Your Phone

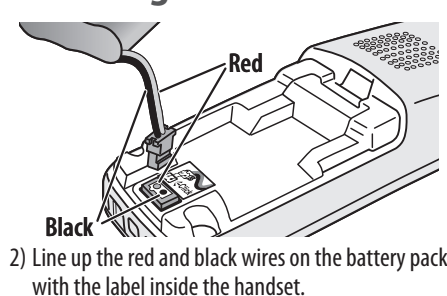

- 3) Push the battery pack connector in until it clicks into place. Tug gently on the wires to make sure the battery pack is securely connected.
- 4) Place the cover over the battery compartment and slide it up into place.

Connect the Power

- 1) Thread the base AC adapter through the hole in the stand and connect it to the DC IN 9V jack on the back of the base. Route the cord through the molded wiring channel as shown.

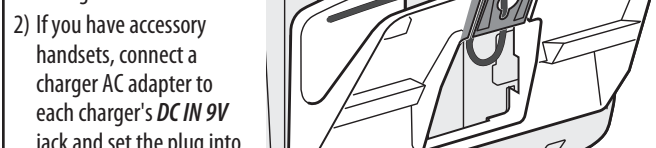

- 2) If you have accessory handsets, connect a charger AC adapter to each charger's DC IN 9V jack and set the plug into the notch as shown.
- 3) Plug the other end of each adapter into a standard 120V AC power outlet.
- 4) Place a handset in the base and any accessory handset(s) in the charger(s) with the display(s) facing forward. The charge light on the base and each charger should all turn on.

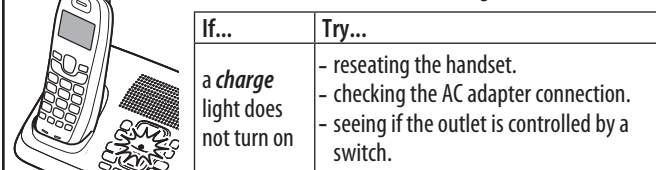

Charge all handsets completely (about 15 hours) before using them.

Connect the Telephone Cord

- 1) Thread the telephone cord through the hole in the stand and connect it to TEL LINE jack. Route the cord through the wiring channel as shown.
- 2) Connect the other end of the cord to a standard telephone wall jack.

Test the connection

- 1) Pick up the handset from the base and press TALK/FLASH. You should hear a dial tone, and the display should say Talk.

If...	Try...
you don't hear a dial tone	checking the connection between the base & the phone jack.

- 2) Make a quick test call. (Press END to hang up.)

If...	Try...
you keep hearing a dial tone	changing the dial mode (see "Global Options" in the Using the Menu section).
there's a lot of noise or static	see the Solving General Problems section for tips on avoiding interference.

Register Any Accessory Handsets

If you have accessory handsets, you have to register them to the base.

- 1) One by one, place each handset in the base cradle. (The charge light should flash.)
- 2) Wait at least 5 seconds, then pick up the handset and press TALK/FLASH.
- 3) If you hear a dial tone, hang up and go on to the next handset. If not, put the handset back in the base and try again.

Most Commonly Asked Questions

How do I...	With the earpiece	With the handset speakerphone
make a call?	Dial the number, then press TALK/FLASH. (To switch the call to the speaker, press SPEAKER.)	Dial the number, then press SPEAKER. (To switch the call to the earpiece, press SPEAKER.)
answer a call?	Press TALK/FLASH.	Press SPEAKER.
hang up?	Press END or return the handset to the cradle.	
redial the last number?	Press REDIAL/PAUSE, then press TALK/FLASH.	Press REDIAL/PAUSE, then press SPEAKER.
change the volume?	While you're listening to the audio, press UP to make it louder or DOWN to make it softer	

What Do the Handset Keys Do?

Key name (& icon)	Press to...
PHONEBOOK (📖/memory)	- In standby or during a call: open the phonebook.
UP (▲/📧)	- In standby: access your answering system. - During a call: increase the call volume. - In the menu or any list: move the cursor up one line.
CALLER ID/MENU (cid)	- In standby or during a call: open the Caller ID list. - In standby: press and hold to open the menu.
DOWN (▼)	- During a call: decrease the call volume. - In the menu or any list: move the cursor down one line.
TALK/FLASH	- In standby: start a telephone call (get a dial tone). - During a call: switch to a waiting call.

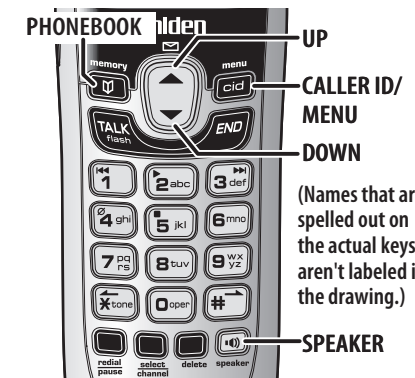

Key name (& icon)	Press to...
END	- While the phone is ringing: mute the ringer for this call only. - In the menu or any list: exit the menu & go back to standby.
Any NUMBER key (0-9)	- In standby: press and hold to open the phonebook entry assigned to this key (see Using the Phonebook).
REDIAL/PAUSE	- In standby: redial the last number you dialed. - During a phone number entry: insert a two-second pause.
SELECT/CHANNEL	- In the menu or any list: select the highlighted item. - During a call: change frequencies to avoid interference.
DELETE	- While entering text: delete the last character, or press and hold to delete all the characters.
SPEAKER (🔊)	- Switch a normal call to the speakerphone (and back).

What Do the Base Keys Do?

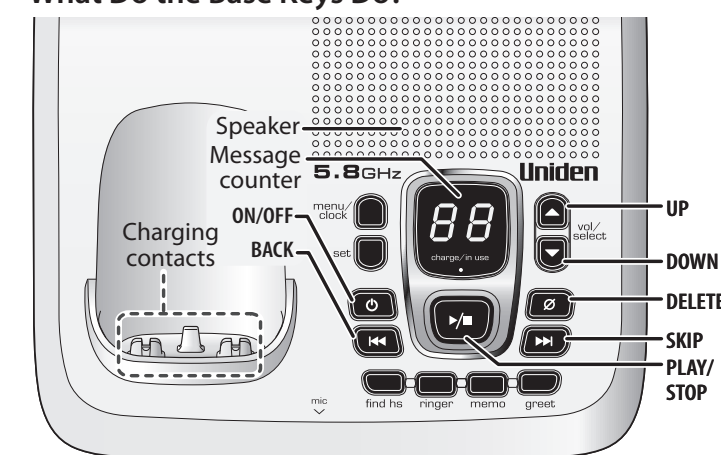

Using the Menu

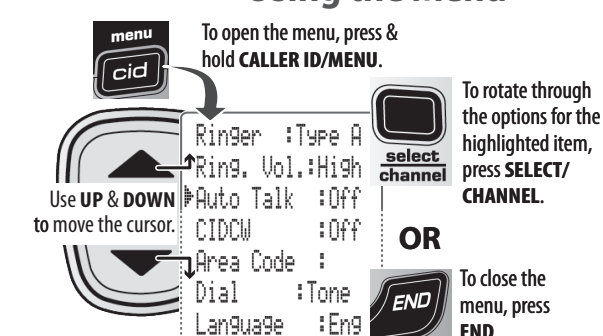

If you don't press any keys for 30 seconds, the phone times out and exits the menu.

Handset-specific Options

The settings below only affect this handset. If you have more than one handset, you have to change these settings separately for each handset.

Ringer	Choose one of 4 ring tones. As you cycle through the tones, the phone plays a sample of each one.
Ring Vol.	Change the ringer volume. Your options are High, Low, and Off. If you turn the ringer volume Off, this handset won't ring.
Auto Talk	Turn on Auto Talk so you can answer the phone just by picking up the handset from the cradle (without to pressing any buttons).
Area Code	If you dial 7 digits to make a local call (instead of 10), you can hide the area code on local calls. Enter your area code and press SELECT/CHANNEL.
Language	Change the language used in the display.

Global Options

These settings effect the base and any accessory handsets you might have. If you have more than one handset, you can only change these settings from Handset 1 (HS1), and you must put Handset 1 back in the base to activate your changes.

CIDCW	Turn on Caller ID on Call Waiting so you can see Caller ID information for any calls that come in when you are on the line. (You must subscribe to Caller ID and Call Waiting through your telephone provider.)
Dial	Change from Tone to Pulse dialing to support older telephone networks.

Entering text in your phone

The letters on the number keys appear in order: press the 2 key once for A, twice for B, and three times for C. You can also enter lower case letters and symbols (the table shows all the available characters and what keys to press to enter them). To enter two characters that are on the same key, enter the 1st character, move the cursor to the right, then enter the 2nd character. For example, to enter Mom:

1. Press 6 once to enter M.
2. Press #/→ to move the cursor to the right.

keys	1	2	3	4	5	6	7	8	9
(1) 1	1								
(2) abc	A	B	C	a	b	c	2		
(3) def	D	E	F	d	e	f	3		
(4) ghi	G	H	I	g	h	i	4		
(5) jkl	J	K	L	j	k	l	5		
(6) mno	M	N	O	m	n	o	6		
(7) pqrs	P	Q	R	S	p	q	r	s	7
(8) tuv	T	U	V	t	u	v	8		
(9) wxyz	W	X	Y	Z	w	x	y	z	9
(0) space	*	#	-	&	<	>	(blank)	0	

3. Press 6 six times to enter o.
4. Press #/→ to move the cursor to the right.
5. Press 6 four times to enter m.
- To insert text, put the cursor on the character directly to the right of where the new text should go. New text is inserted to the left of the cursor.
- If you made a mistake, move the cursor to highlight the incorrect character and press DELETE. Then enter the correct character.
- To delete all the characters, press and hold DELETE.

Key (icon)	What it does
BACK (◀◀)	- In the first 2 seconds of a message: go to the previous message. - Anytime after that: go back to the beginning of this message.
DELETE	- While a message is playing: delete this message. - In standby: delete all messages.
SKIP (▶▶)	- While a message is playing: skip to the next message.
PLAY/STOP	- In standby: start playing new messages. - While a message is playing: stop playing messages. - While the phone is ringing: mute the ringer for this call only.
DOWN (▼)	- In standby or while a message is playing: decrease the speaker volume.
UP (▲)	- In standby or while a message is playing: increase the speaker volume.
FIND HS	- In standby: page all handsets so you can find a lost one.
RINGER	- In standby or while the phone is ringing: cycle through the available ringer volume settings (Off, Low and High).
MEMO	- In standby: press & hold to record a voice memo on your answering system.
GREET	- In standby: switch between your personal greeting and the pre-recorded greeting.

Using the Phonebook

Each handset can store up to 10 names and phone numbers in its phonebook. The 10 entries correspond to 0 - 9 on the twelve-key dial pad.

Each phone number can be up to 20 digits. If you need the phone to wait before dialing the next digit (for example, to enter an extension number) press REDIAL/PAUSE to insert a 2-second pause (shown as a P in the display). You can add as many pauses as you want anywhere in the phone number, but each pause does count as 1 digit.

Open or close the phonebook	Press PHONEBOOK.
Find an entry	Use UP and DOWN to scroll through the list, or press the number corresponding to the entry you are looking for.
Dial an entry	Find the entry you want to dial & press TALK/FLASH (or SPEAKER).
Create a new entry	Find an <Empty> phonebook entry and press SELECT/CHANNEL. The handset prompts you to enter the name and phone number. Press SELECT/CHANNEL when you're finished at each step.
Edit an entry	Edit the entry you want to edit. Press SELECT/CHANNEL and select Edit Memory. The handset prompts you to edit the name and phone number: press SELECT/CHANNEL when you finish with each step.
Delete an entry	Find the entry you want to delete. Press SELECT/CHANNEL and select Delete Memory. When the handset asks you to confirm, select Yes.
Save a Caller ID number into your phonebook	On the CID list, find the number you want to save. (If this is a toll call, make sure the number has a 7 at the front; if it doesn't, press 1.) Then, open the phonebook and find the entry you want to use for this number. Press SELECT/CHANNEL.

Chain Dialing

If you often have to enter a code number during a call, you can save that code number to a phonebook entry and use the phonebook to send the code number.

- ◆ Enter the code number into the phonebook just like a regular phonebook entry; make sure to enter it into the phonebook exactly as you would enter it during a call.
- ◆ Make your call normally. When you hear the prompt that tells you to enter the number, open the phonebook and find the entry that contains your code number. Press SELECT/CHANNEL to transmit the code.

Using Caller ID and Call Waiting

You must subscribe to Caller ID, Call Waiting & CID on Call Waiting to use the features described below: contact your telephone provider for information.

When a call comes in, the phone displays the caller's number and name (if available). If a call comes in when you're on the line, the phone sounds a tone and displays any CID information received for the waiting call.

Each handset saves CID information for the last 30 calls to the *CID list*. When you open the CID list, the phone shows how many calls came in since you last checked the list.

Open or close the CID list	With the phone in standby, press CID/MENU .
Scroll through the CID list	Press DOWN to scroll through the list from newest to oldest. Press UP to scroll from oldest to newest.
Erase the entire CID list	From the summary screen, press DELETE .
Erase 1 number from the list	Find the number you want to erase and press DELETE .
Dial a number from the list	1. Find the number you want to dial. (If this is a toll call, make sure the number in the CID list has a 7 at the front; if it doesn't, press 1.) 2. Press TALK/FLASH to dial the number.
Answer a waiting call	Press TALK/FLASH to switch between your current call and the waiting call. Each time you switch, there's a short pause before you're connected to the other call.

Using Call Transfer

If you have more than one handset, you can transfer a call to any other handset, but you must know the number of the handset. When a handset is charging, the top right corner of the display shows the handset number (HS1, HS2, etc.).

transfer a call	1. Press DELETE (DELETE/TRANSFER) to put the call on hold. 2. Press the number key corresponding to the handset you want to transfer the call to. (1 for HS 1, 2 for HS2, etc.) When the other handset accepts the call, you'll be disconnected.
cancel a transfer	To return to the call, press TALK/FLASH .
accept a call transfer	Press TALK/FLASH .

Solving General Problems

If you have any trouble with your phone, try these simple steps first. If you still have a question, call our Customer Care Line listed on the front cover.

If...	Try...
I can't make or receive calls.	- Checking the telephone cord connection. - Disconnecting the base AC adapter. Wait a few minutes, then reconnect it.
A handset can make calls, but it won't ring.	- Making sure the ringer is turned on.
A handset is not working.	- Checking the battery pack connection. - Charging the battery for 15-20 hours. - Re-registering all handsets.
A handset says <i>Unavailable</i> .	- Moving the handset closer to the base. - Making sure the base is plugged in.
No handsets will display any Caller ID information.	- Letting incoming calls ring at least twice before answering. - Seeing if the call was placed through a switchboard. - Making sure your Caller ID service is active
I can't dial from the CID list.	- Making sure you entered the correct area code. If you have to dial all 10 digits, you need to delete the area code.
I can't transfer calls.	- Re-registering all handsets.

Noise or Static On The Line

The most common cause of noise or static on a cordless phone is interference. Here are some common household sources of interference:

- ◆ electrical appliances, especially microwave ovens
- ◆ computer equipment, especially wireless LAN equipment and DSL modems
- ◆ radio-based wireless devices, such as room monitors, wireless controllers, or wireless headphones or speakers
- ◆ large florescent light fixtures (especially if they give off a buzzing noise)

- ◆ other services that use your phone line, like alarm systems, intercom systems, or broadband Internet service

If the static is... on 1 handset/in 1 location:	on all handsets/in all locations:
- Press SELECT/CHANNEL to change frequencies. - Check nearby for one of the interference sources. - Try moving the handset away from a suspected source, or try moving the source so it's not between the handset and the base. - Try moving closer to the base. There is always more noise at the edges of the base's range.	- Check near the base for the source of interference. - Try moving the base away from a suspected source, or turn off the source if possible. - If you have any service that uses the phone line, you might need a filter (see below).

Installing a telephone line filter or DSL filter
Broadband Internet services that use the phone line can interfere with telephones. One common service—DSL—often causes static on telephones. A *DSL filter* or line filter usually solves this problem. (The technician who installed your DSL service might have left some filters for you; if not, call your DSL provider or look in any electronics store.) Plug the DSL filter into the telephone wall jack and then plug your phone's base into the filter. Make a test call to make sure the noise is gone.

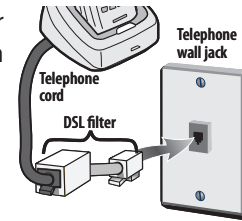

Using the Answering System

Using the Answering System Menus

Use **MENU/CLOCK** to cycle through the available options; press **PLAY/STOP** to exit:

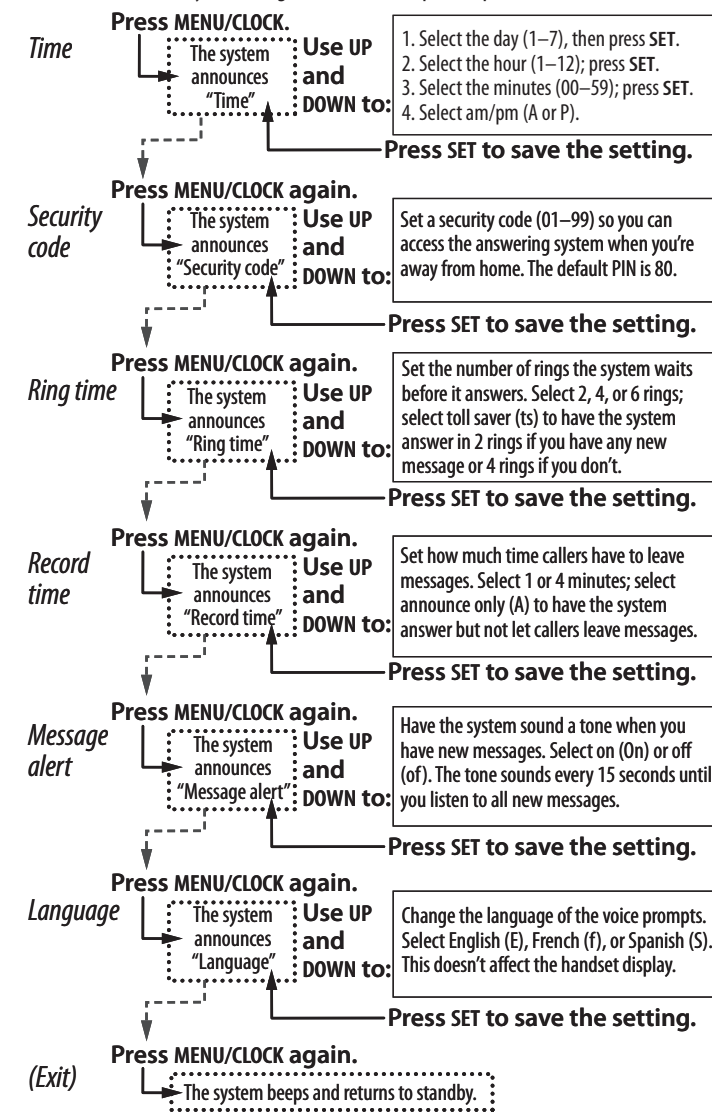

Setting Your Outgoing Message

Your personal outgoing message or greeting can be between 2 seconds and 30 seconds long. If you don't want to record an outgoing message, the system will use its pre-recorded greeting:

Record your greeting	1. Press and hold GREET until the system says "Record greeting" (about two seconds). 2. Begin speaking. (The message counter light starts counting down from 30 so you know how many seconds are left.) 3. When you finish, press SET . The system plays back your new greeting.
Switch greetings	Press GREET . The system plays back the greeting it is currently using. Press GREET again to switch greetings.
Delete your greeting	Switch to your personal greeting following the steps above. While the system is playing back your greeting, press DELETE .

Turning Your Answering System On

With the phone in standby, press **On/Off** on the base. When the answering system is on, the message counter shows the number of new messages.

Getting Your Messages

The icons above the numbers on the handset match up with the same keys on the base.



To...	From the base	From a handset
play new messages	Press PLAY/STOP . The system announces the number of new and old messages, then plays new messages in the order they were received. After each message, the system announced the day and time it was received.	Press UP/MESSAGES , then 2.
restart the current message	Press BACK .	Press 1
replay previous messages	Press BACK repeatedly until you hear the message you want.	Press 1 repeatedly until you hear the message you want.
skip a message	Press SKIP .	Press 3.
delete a message	While the message is playing, press DELETE .	While the message is playing, press 4
delete all of your messages	With the phone in standby, press DELETE . When the system asks you to confirm, press DELETE again.	Not available.
play old messages	After the system plays the new messages, press PLAY/STOP again.	press 2.
end the operation	Press PLAY/STOP .	press 5.

Using the System While You're Away from Home

You can also operate your answering system from any touch-tone phone. Before you can use this feature, you have to program a security code (see the menu options, above).

Remember to make a note of your new security code!

Dialing in to your system

- 1) Call your telephone number and wait for the system to answer. (If your answering system is off, it will answer after about ten rings and sound a series of beeps instead of your greeting.)
- 2) During the greeting (or beeps), press **0** and **immediately** enter your security code. (You have 3 tries to enter your security code: if you enter it wrong 3 times, the system hangs up and returns to standby.)
- 3) The system announces the current time, the number of messages stored in memory, and a help prompt. Then it starts beeping intermittently to let you know it's waiting for your command.
- 4) When you hear the intermittent beeping, enter a command from the chart to the right.

0-1	Repeat message	0-5	Stop playback
0-2	Play message	0-6	Turn the system on
0-3	Skip message	0-9	Turn the system off
0-4	Delete message	1-0	Hear help prompts

If you don't press any keys for 15 seconds, the phone will hang up and return to standby.

Solving Problems with Your System

Below are the most common problems customers have with their answering system and how to resolve them. If you don't see your problem listed, contact our Customer Care Center (see the front cover for contact information).

If...	Try...
The answering system does not work.	- Making sure the answering system is turned on. - Making sure the base AC adapter is plugged into a continuous outlet (i.e., not controlled by a wall switch).
The system won't record messages.	- Making sure the <i>Record Time</i> isn't set to <i>Announce Only</i> . - Deleting saved messages (the memory may be full).
My outgoing message is gone.	- Seeing if there was a power failure. You may have to re-record your personal outgoing message.
I can't hear the base speaker.	- Changing the base speaker volume.
Messages are incomplete.	- The incoming messages may be too long. Remind callers to leave a brief message. - Deleting saved messages (the memory may be full).
I can't dial in to my system from another phone	- Making sure you have programmed a security code. - Making sure you are entering the correct code.

Wall Mounting the Base

You can mount the base on a standard telephone wall plate.

- 1) On the back of the base, press in on the tabs and remove the desk stand.

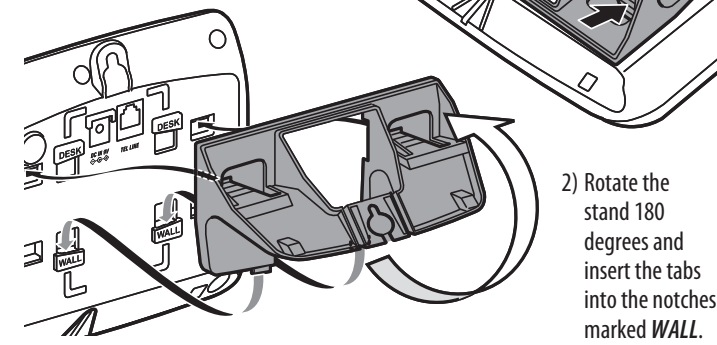

- 2) Rotate the stand 180 degrees and insert the tabs into the notches marked **WALL**.

- 3) Press the tabs in and insert them into the notches near the top of the base.

- 4) Connect the AC adapter and telephone cords. Route the AC adapter cord through the molded wiring channel on the right side of the stand as shown.

- 5) Connect the telephone cord to the wall jack. Tuck the excess cord into the open space in the bracket.

- 6) Place the mounting slots over the pins on the wall plate, and slide the base down to lock it into place.

Important Information

Specifications

	AC adapters	
	Base	Charger
Part number	PS-0003	PS-0007
Input voltage	120V AC, 60 Hz	120V AC, 60 Hz
Output voltage	9V DC @ 350mA	9V DC @ 210mA
Battery pack		
Part number	BT-1019	
Capacity	400mAh, 3.6V DC	

- ◆ Use only the supplied AC adapters.
- ◆ Be sure to use the proper adapter for the base and any chargers.
- ◆ Do not place the power cord where it creates a trip hazard or where it could become chafed and create a fire or electrical hazard.
- ◆ Do not place the base in direct sunlight or subject it to high temperatures.

Compliance Information

FCC Part 68 information

This equipment complies with Part 68 of the FCC rules and the requirements adopted by the ACTA. On the bottom of this equipment is a label that contains, among other information, a product identifier in the format US: AAAEQ#TXXXX. If requested, this number must be provided to the phone company.

An applicable Universal Service Order Codes (USOC) certification for the jacks used in this equipment is provided (i.e., RJ11C) in the packaging with each piece of approved terminal equipment. A plug and jack used to connect this equipment to the premises wiring and telephone network must comply with the applicable FCC Part 68 rules and requirements adopted by the ACTA. A compliant telephone cord and modular plug is provided with this product. It is designed to be connected to a compatible modular jack that is also compliant. See installation instructions for details.

The REN is used to determine the number of devices that may be connected to a phone line. Excessive RENs on a phone line may result in devices not ringing in response to an incoming call. In most but not all areas, the sum of RENs should not exceed five (5.0). To be certain of the number of devices that may be connected to a line, as determined by the total RENs, contact the telephone provider. The REN for this product is part of the product identifier that has the format US:AAEQ#TXXXX. The digits represented by # are the REN without a decimal point (e.g., 03 is a REN of 0.3).

If this equipment causes harm to the telephone network, the telephone company will notify you in advance that temporary discontinuance of service may be required. But if advance notice isn't practical, the telephone company will notify the customer as soon as possible. Also, you will be advised of your right to file a complaint with the FCC if you believe it is necessary. The telephone company may make changes in its facilities, equipment, operations or procedures that could affect the operation of the equipment. If this happens the telephone company will provide advance notice in order for you to make necessary modifications to maintain uninterrupted service.

Please follow instructions for repairing, if any (e.g. battery replacement section); otherwise do not substitute or repair any parts of the device except as specified in this manual. Connection to party line service is subject to state tariffs. Contact the state public utility commission, public service commission or corporation commission for information. This equipment is hearing aid compatible.

If you experience trouble with this equipment, contact the manufacturer (see the cover of this manual for contact information) or an authorized agent. If the equipment is causing harm to the telephone network, the telephone company may request that you disconnect the equipment until the problem is resolved.

If your home has wired alarm equipment connected to a phone line, be sure that installing the system does not disable your alarm equipment. If you have questions about what will disable alarm equipment, contact your telephone company or a qualified installer.

Any changes or modifications to this product not expressly approved by the manufacturer or other party responsible for compliance could void your authority to operate this product.

NOTICE: According to telephone company reports, AC electrical surges, typically resulting from lightning strikes, are very destructive to telephone equipment connected to AC power sources. To minimize damage from these types of surges, a surge arrester is recommended.

FCC Part 15 information

This device complies with part 15 of the FCC rules. Operation is subject to the following two conditions: (1) This device may not cause harmful interference, and (2) This device must accept any interference received, including interference that may cause undesired operation. Privacy of communications may not be ensured when using this phone.

FCC PART 15.105(b): Note: This equipment has been tested and found to comply with the limits for a Class B digital device, pursuant to part 15 of the FCC Rules. These limits are designed to provide reasonable protection against harmful interference in a residential installation. This equipment generates, uses and can radiate radio frequency energy and, if not installed and used in accordance with the instructions, may cause harmful interference to radio communications. However, there is no guarantee that interference will not occur in a particular installation. If this equipment does cause harmful interference to radio or television reception, which can be determined by turning the equipment off and on, the user is encouraged to try to correct the interference by one or more of the following measures:

- ◆ Reorient or relocate the receiving antenna.
 - ◆ Increase the separation between the equipment and receiver.
 - ◆ Connect the equipment into an outlet on a circuit different from that to which the receiver is connected.
 - ◆ Consult the dealer or an experienced radio/TV technician for help.
- This product complies with FCC radiation exposure limits under the following conditions:
- ◆ The base must be placed to allow a minimum of 20 cm (8 inches) between the antenna and all persons during normal operation.
 - ◆ The base must not be collocated or operated in conjunction with any other antenna or transmitter.
 - ◆ The handset is designed for body-worn operation and meets FCC RF exposure guidelines when used with any belt clip, carrying case, or other accessory supplied with this product. (All necessary accessories are included in the package; any additional or optional accessories are not required for compliance with the guidelines.) Third party accessories (unless approved by the manufacturer) should be avoided as these might not comply with FCC RF exposure guidelines.

Industry Canada (I.C.) Notice

Terminal equipment

NOTICE: This equipment meets the applicable Industry Canada Terminal Equipment Technical Specifications. This is confirmed by the registration number. The abbreviation /C before the registration number signifies that registration was performed based on a Declaration of Conformity indicating that Industry Canada technical specifications were met. It does not imply that Industry Canada approved the equipment.

NOTICE: The Ringer Equivalence Number (REN) for this terminal equipment is marked on the equipment itself. The REN assigned to each terminal equipment provides an indication of the maximum number of terminals allowed to be connected to a telephone interface. The termination on an interface may consist of any combination of devices subject only to the requirement that the sum of the RENs of all the devices does not exceed 5.

Radio equipment

The term /C before the radio certification number only signifies that Industry Canada technical specifications were met. Operation is subject to the following two conditions: (1) this device may not cause interference, and (2) this device must accept any interference, including interference that may cause undesired operation of the device. *Privacy of communications may not be ensured when using this telephone*.