

**Uniden®**

**MHS75**

**VHF MARINE RADIO**

**RADIO VHF MARITIME**



**OWNER'S MANUAL  
GUIDE D'UTILISATION**

## Making a Distress Call

For future reference, write your boat's name & call sign here:

### ***Speak slowly -- clearly -- calmly.***

1. Make sure your radio is on.
2. Press the **16/9-Tri** button to switch to Channel 16 (156.800 MHz). (If the corner of the display does not show 16, press the **16/9-Tri** button again until it does.)
3. Press the **Push to talk** button and say, **"MAYDAY --MAYDAY-- MAYDAY."**
4. Say, **"THIS IS {name or call sign of your boat}."**
5. Say, **"MAYDAY {name or call sign of your boat}."**
6. Tell where you are (what navigational aids or land-marks are near, or give your position from a GPS).
7. State the nature of your distress (e.g. sinking, medical emergency, man overboard, fire, adrift, etc.).
8. Give the number of persons aboard and describe the condition of any injured persons.
9. Estimate present seaworthiness of your ship (e.g. how immediate is the danger due to flooding or fire or proximity to shore).
10. Briefly describe your ship (length, type, color, hull).
11. Say, **"I WILL BE LISTENING ON CHANNEL 16."**
12. End message by saying, **"THIS IS {name or call sign of your boat} OVER."**
13. Release the **Push to talk** button and listen for a response.

***If you do not get an answer after 30 seconds, repeat your call, beginning at step 3, above.***

## Table of Contents

### Making a Distress

Call ..... (inside front cover)

Introduction..... E-1

Features ..... E-1

Getting Started..... E-2

What's included ..... E-2

Parts of the MHS75 ..... E-3

Front view..... E-3

Back view ..... E-3

DC Charger ..... E-4

Reading the display ..... E-5

Display icons and what they  
mean ..... E-5

How It Works..... E-6

Normal mode operation ..... E-7

Normal mode with Weather Alert  
Watch ..... E-7

Normal mode with Triple Watch or  
Dual Watch..... E-8

Normal mode with Quad Watch . E-8

Scan mode operation ..... E-9

Using the radio in scan mode .... E-9

Scan mode with Weather Alert  
Watch ..... E-10

Scan mode with Triple Watch or  
Dual Watch..... E-10

Both Weather Alert and Triple/Dual  
Watch in scan mode..... E-10

Weather mode ..... E-11

Using the radio in weather  
mode ..... E-11

Weather mode with Weather Alert  
Watch ..... E-11

Weather mode with Triple Watch  
or Dual Watch ..... E-12

Setting Up the Hardware..... E-12

Attaching the antenna..... E-12

Installing the battery ..... E-12

Charging the battery ..... E-13

Connecting the charger ..... E-13

Important notes on charging the  
battery ..... E-13

Disconnecting the charger ..... E-14

Attaching the belt clip ..... E-14

Using Your Radio..... E-15

Changing the volume ..... E-15

Setting the squelch level..... E-15

Changing the channel..... E-15

Making a transmission..... E-16

Boosting the transmission  
power ..... E-16

Setting the UIC channel mode... E-17

Maintenance and

Troubleshooting..... E-17

Common questions..... E-17

Specifications ..... E-18

Channels and Frequencies..... E-19

US channel frequencies and  
names ..... E-19

Canadian channel frequencies and  
names ..... E-21

International channel frequencies  
and names ..... E-23

Weather channel frequencies and  
names ..... E-25

Regulations and Safety

Warnings..... E-26

Maritime radio services  
operation..... E-26

Basic radio guidelines..... E-26

FCC/Industry Canada  
information ..... E-27

FCC RF exposure information... E-27

Lithium ion battery warning..... E-28

Three Year Limited Warranty

Statement ..... E-29

# Introduction

## Features

The MHS75 provides the following key features:

- **Submersible design**  
Complies with JIS8/IPX8 water-resistant standards, which means the radio can be submerged in 1.5 meters of water for 30 minutes without damage.
- **Memory scan mode**  
Lets you save channels to memory and monitor them in quick succession.
- **Transmitter power level select**  
Lets you boost the transmitter power from 1 Watt to 2.5 or 5 Watts for added transmission distance.
- **Battery level display and low battery alert.**
- **Dual, Triple and Quad Watch operation**  
These different watch modes let you monitor up to two Coast Guard Distress/Hailing channels and one weather channel along with one regular marine channel.
- **All marine VHF channels for the U.S., Canada, and international waters**
- **National Oceanic and Atmospheric Administration (NOAA) weather channel watch**  
Sounds a warning tone when a hazard alert is issued.

# Getting Started

## What's included



MHS75 Radio



Antenna



DC Charger

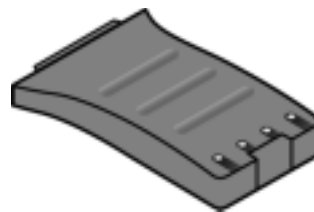

Lithium Ion Battery



Belt Clip



Wrist Strap

If any pieces are missing or damaged, contact Uniden Customer Service (see back cover for contact information). For information on available accessories, visit [www.uniden.com](http://www.uniden.com).

## Parts of the MHS75

### Front view



### Back view



Knob	Turn clockwise to...:	Turn counter-clockwise to...:
<i>Volume-Power</i>	Turn on the radio or increase the volume.	Decrease the volume or turn off the radio.
<i>Squelch</i>	Raise the squelch level to reduce channel noise.	Lower the squelch level to hear weaker signals.

Button	Press to...	Press and hold to...
<i>Push to talk</i>	NA	Transmit on a channel
<i>16/9-Tri</i>	1st press: Go to channel 16. 2nd press: Go to channel 9. 3rd press: Go back to the starting channel.	Turn Triple Watch on and off.
<i>Mem</i>	Save a channel into memory or delete a channel from memory.	NA
<i>UIC-Lock</i>	Switch from US to Canadian or international channels.	Lock the keys; press and hold again to unlock.
<i>Channel Up</i>	Move up one channel at a time.	Move quickly up the channels.
<i>Channel Down</i>	Move down one channel at a time.	Move quickly down the channels.
<i>WX-Alert</i>	Listen to the weather channels.	Turn Weather Alert Watch on and off.
<i>Scan-Dual</i>	Start scanning the channels saved in memory.	Turn Dual Watch on and off.
<i>1/5W-2.5W</i>	Switch the transmit power between 1 Watt and 5 Watts.	Change the transmit power to 2.5 Watts.

## DC Charger

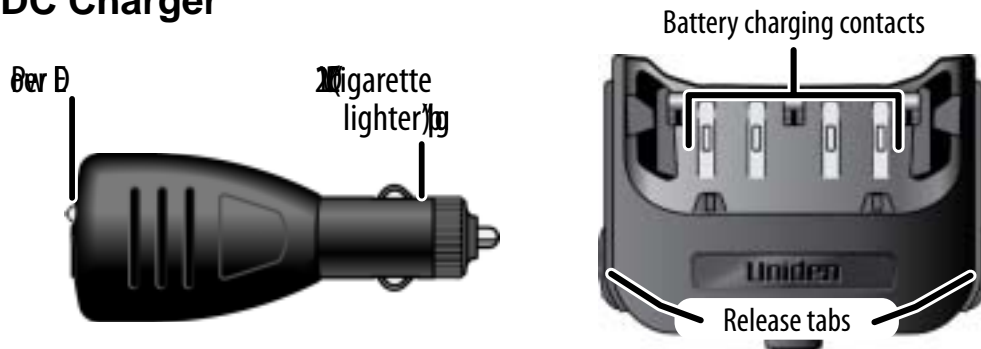

## Reading the display

The LCD display shows different information depending on what you are doing. This sample screen shows some of this information. The table below shows all the possible icons and what they mean.

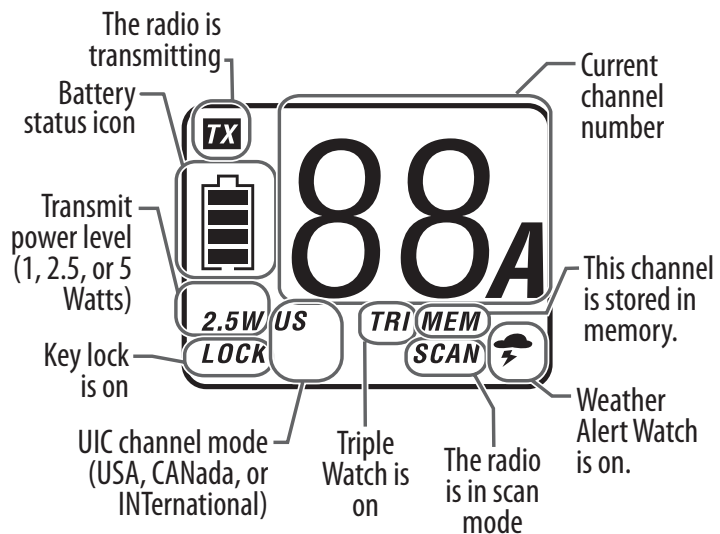

## Display icons and what they mean

Icon	What it means
<b>TX</b>	You are currently transmitting.
<b>1W, 5W, or 2.5W</b>	The transmitter power is set to 1 Watt, 5 Watts, or 2.5 Watts.
<b>LOCK</b>	The keys are locked.
<b>US, CAN, or INT</b>	The radio is set to use US channels, CANadian channels, or INternational channels.
<b>TRI or DUAL</b>	TRiple Watch or DUAL Watch is turned on.
<b>MEM</b>	The current channel is saved in memory.
<b>SCAN</b>	The radio is in Scan mode.
<b>WX</b>	The radio is in Weather Mode
	Weather Alert Watch is turned on.
	The battery is fully charged, mostly charged, half charged, mostly empty, or completely empty.



## How It Works

The MHS75 radio has three main operation modes: normal mode, scan mode, and weather mode.

Mode	What it does	Use it when you want to...:	To turn it on/off
Normal mode	Monitors a single marine channel and lets you talk on that channel.	Monitor a channel or talk to another radio.	(default mode)
Scan mode	Monitors all the channels you save into memory.	Check a small group of regularly-used channels for traffic.	Press <i>Scan-Dual</i> .
Weather mode	Monitor the selected NOAA weather channel.	You want to hear the current or forecasted weather.	Press <i>WX-Alert</i> .

In addition to the three operation modes, the MHS75 provides four different *watch modes* which you can activate during any operation mode. In the watch modes, the radio briefly checks for activity on a specific channel, then returns to its previous operation.

Watch mode	What it does	To turn it on/off
Weather Alert Watch	Checks the last-used weather channel for hazard alerts every 7 seconds.	Press and hold <i>WX-Alert</i> for 2 seconds.
Dual Watch	Checks channel 16 for activity every 2 seconds.	Press and hold <i>Scan-Dual</i> for 2 seconds.
Triple Watch	Checks channels 16 and 9 for activity every 2 seconds.	Press and hold <i>16/9-Tri</i> for 2 seconds.
Quad Watch	Checks channels 16 and 9 for activity every 2 seconds, and checks the last-used weather channel every 7 seconds.	Turn on Triple Watch, then turn on Weather Alert Watch.

**Note:** Private boats must monitor channel 16 whenever they are underway. Water-going vessels should have either Triple Watch or Dual Watch on at all times.

## Normal mode operation

- To transmit, remove the radio from the charger, then press and hold the **Push to Talk** button. Release the button when you are finished talking.
- For the best sound quality, hold the microphone about two inches from your mouth while you're talking.
- Press the **Channel Up** button to move up one channel at a time. Press and hold the button to scroll quickly up the channels.
- Press the **Channel Down** button to move down one channel at a time. Press and hold the button to scroll quickly down the channels.
- To change the transmit power, press the **1/5W-2.5W** button. The transmit power switches between 1 Watt and 5 Watts each time you press the **1/5W-2.5W** button.
- To change the transmit power to 2.5 Watts, press and hold the **1/5W-2.5W** button for 2 seconds. Press and hold the button again to change back to the previous transmit power (either 1 Watt or 5 Watts).

## Normal mode with Weather Alert Watch

If you activate Weather Alert Watch while operating in normal mode, the radio checks the most recently used weather channel every seven seconds. If it detects a weather or other hazard alert, it will switch to that weather channel. (If you are actively transmitting, the radio waits until you finish your transmission before checking the weather channel.)

Monitoring Channel 25

Every 7 seconds,  
the radio checks  
the last-used  
weather channel.



**WX Alert  
Watch on**

### Normal mode with Triple Watch or Dual Watch

If you activate Triple Watch while operating in normal mode, the radio checks channels 16 and 9 every two seconds; with Dual Watch turned on, the radio only checks channel 16. The radio will not check channels 16 or 9 while you are actively transmitting; it waits until your transmission is finished and then checks the channels.

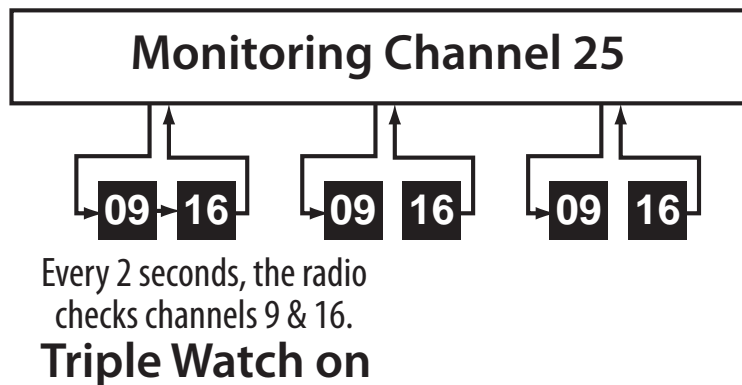

### Normal mode with Quad Watch

You can activate Weather Alert Watch and Triple Watch at the same time to monitor four channels at once (Quad Watch). The radio performs the Triple Watch and Weather Alert Watch checks at their scheduled time:

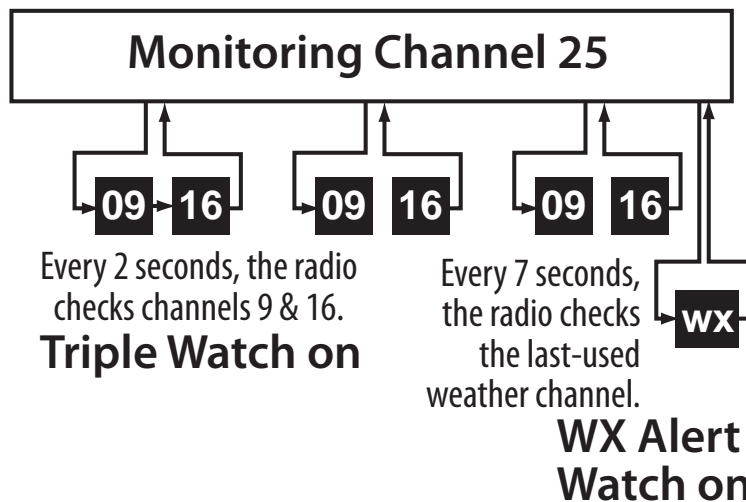

## Scan mode operation

You can save channels into memory and then use scan mode to monitor those channels from lowest to highest. If the radio detects a signal on a channel, it stays on that channel as long as the signal is received; when the signal stops, the radio continues scanning.

When it detects a signal, the radio stays on the channel until you press the **Channel Up** button or the signal stops.

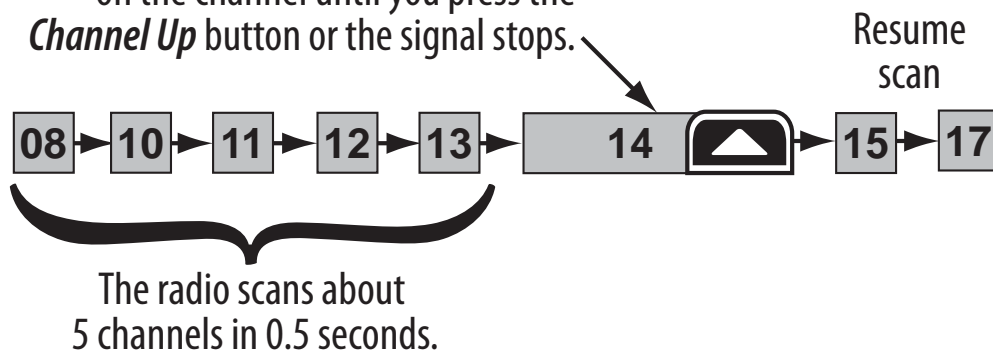

## Using the radio in scan mode

- To activate scan mode, press **Scan-Dual**.
- You must have at least two channels in memory to start a scan.
- You cannot transmit while in scan mode.
- To save a channel into memory, select the channel, then press the **Mem** button. The **Mem** icon shows on the display whenever you tune to that channel.
- To remove a channel from memory, set the radio to that channel, then press the **Mem** button. The **Mem** icon no longer shows on the display.
- When the radio stays on a channel, press **Channel Up** to leave that channel and resume scanning.
- To end the scan, press the **Scan-Dual** button again; the radio remains on the last scanned channel.

### Scan mode with Weather Alert Watch

If you activate Weather Alert Watch while in scan mode, the radio checks the most recently-used weather channel every seven seconds, then continues scanning the next channel in memory:

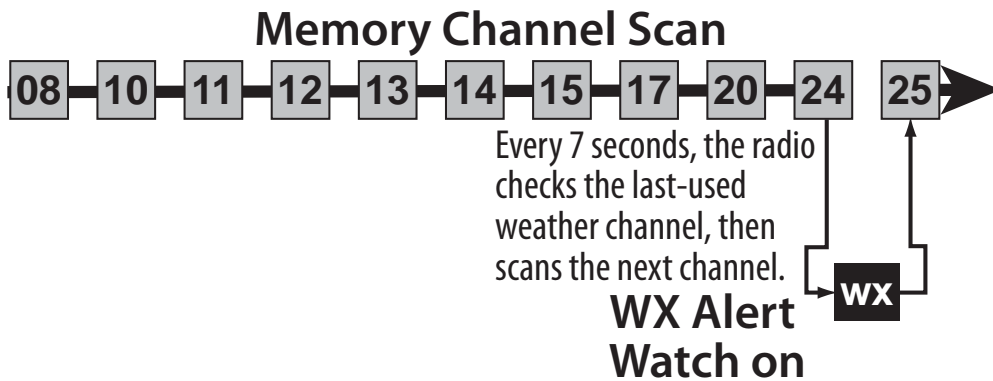

### Scan mode with Triple Watch or Dual Watch

If you activate Triple Watch while operating in scan mode, the radio checks channels 16 and 9 every two seconds, then goes on to scan the next channel; with Dual Watch turned on, the radio only checks channel 16:

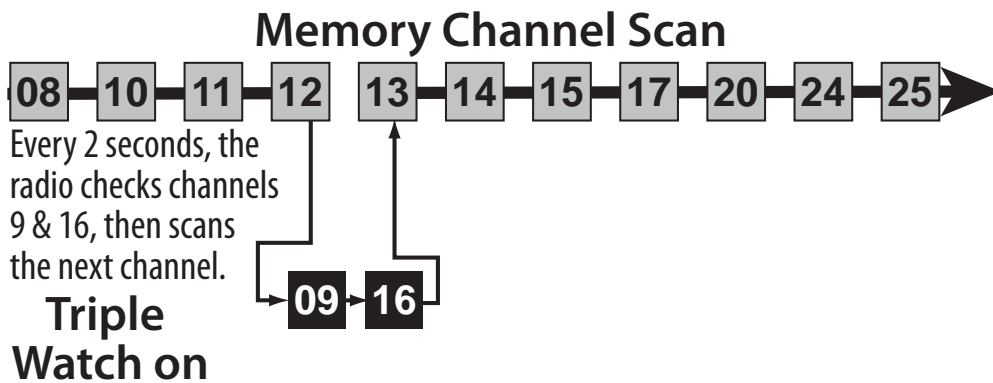

### Both Weather Alert and Triple/Dual Watch in scan mode

You can activate Weather Alert Watch and Triple/Dual Watch at the same time. The radio performs both checks at their scheduled time:

## Memory Channel Scan

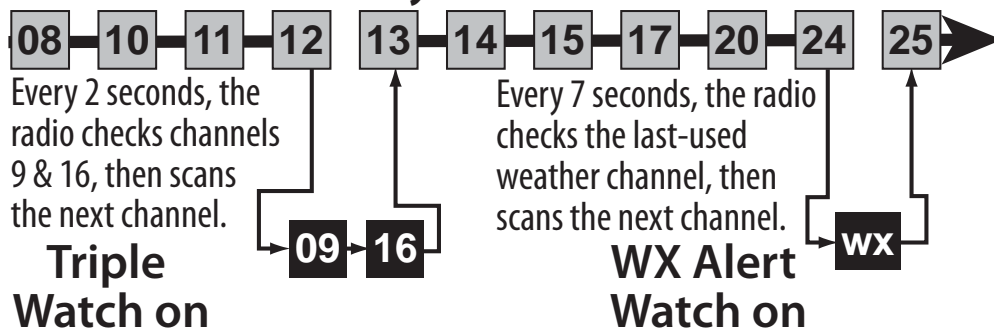

## Weather mode

The NOAA weather channels now cooperate with the FCC to alert you of other hazards besides weather (child abduction alerts, nuclear, biological, etc.). In weather mode, the radio monitors one of the ten NOAA weather channels. If any type of alert is received, the radio sounds an alert tone and the display blinks.

### Using the radio in weather mode

- You cannot transmit while in weather mode.
- To enter weather mode, press the **WX-Alert** button.
- To turn off the radio's alert tone, press any button.
- To cancel weather mode and return to the previous marine channel, press the **WX-Alert** button again.

### Weather mode with Weather Alert Watch

Because weather mode already monitors the weather channels, you don't need Weather Alert Watch to check the weather channel every seven seconds. If you activate Weather Alert Watch while operating in weather mode, it operates as a type of "sleep mode": the radio stays on the weather channel and mutes the speaker. If an alert is detected, the radio sounds an alert tone and turns the speaker back on. This mode is very useful when you are anchoring for the night but want to keep informed of hazards.

## Weather mode with Triple Watch or Dual Watch

If you activate Triple Watch while operating in weather mode, the radio checks channels 16 and 9 every two seconds; with Dual Watch turned on, the radio only checks channel 16.

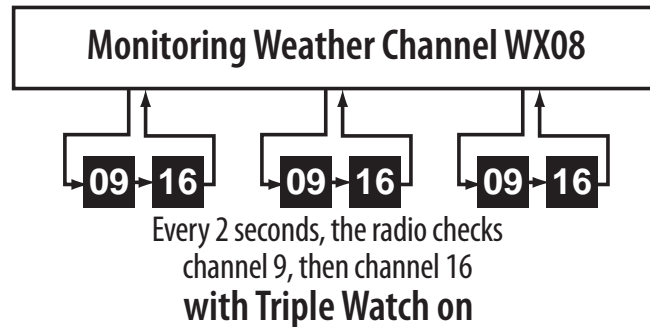

## Setting Up the Hardware

### Attaching the antenna

The antenna detaches from the radio for easy shipping or storage. To attach the antenna to your radio, screw it tightly onto the anchor post at the top of the radio.

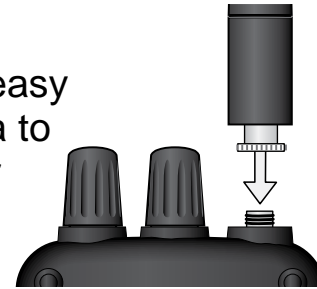

### Installing the battery

Your MHS75 comes with a rechargeable Lithium Ion battery; for shipping safety, the battery is not installed at the factory.

1. Insert the hook on the battery into the notch at the top of the battery compartment.

**Note:** Each time you remove the battery, check the rubber seal around the battery compartment. Make sure the seal is seated in the groove and there is no dirt or debris on it. If the seal looks worn or damaged, contact customer service to order a replacement (see back cover page for contact information).

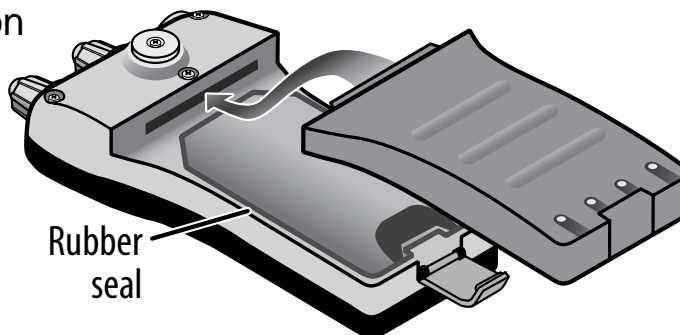

2. Lower the battery until it rests flat in the compartment.
3. Bring the battery latch up and snap it into place.

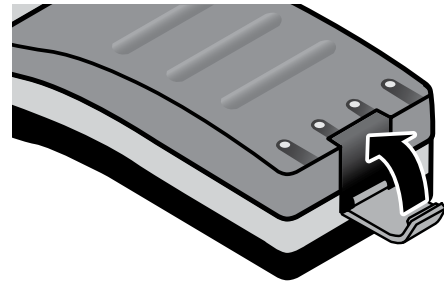

## Charging the battery

### Connecting the charger

Align the charger with the battery (on the rear side of the radio). Slide the radio into the charger until it clicks into place.

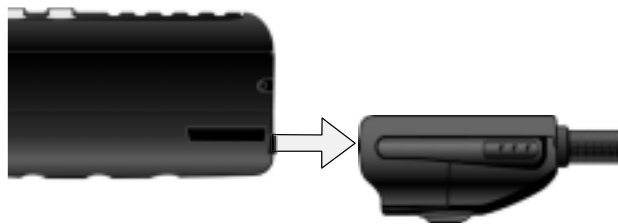

Connect the other end of the charger to any standard 12 volt DC “cigarette lighter” style outlet. The power LED on the top of the plug should turn orange and remain lit.

**CAUTION:** If the LED blinks, *immediately* disconnect the charger from the DC outlet. Reseat the radio in the charger before reconnecting the charger to power.

**CAUTION:** Use only the battery and charger supplied with this radio. Using a different charger or battery can damage the radio and create a risk of fire or shock.

### Important notes on charging the battery

- Charge the battery fully before using the radio.
- When the battery is completely charged, the power LED turns green.
- Don't use the charger when the ambient temperature is below 0° C (32° F) and 45° C (113° F).
- If the radio is powered down, the battery can charge in about three and a half hours. (If the radio is powered on, the battery takes longer to charge.)
- If the battery is empty, the radio can't transmit, even if it's in the charger.



- Be careful moving the charger cord. If you have to move the cord while the radio is charging, pick up the radio first so you don't drop it.

### Disconnecting the charger

Squeeze in on the release tabs at the base of the charger, and slide the radio out.



### Attaching the belt clip

To attach the belt clip:

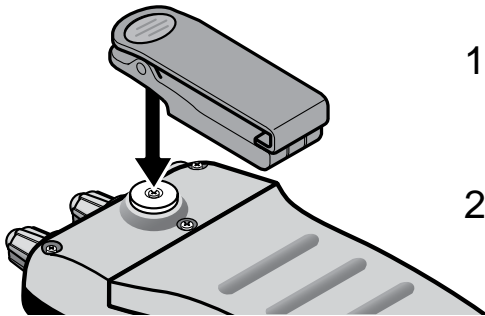

1. Rotate the belt clip so that the finger indentation is towards the top of the radio.
2. Align the center of the clip with the anchor post.

3. Place the clip on the post and slide the clip upwards until it clicks into place.

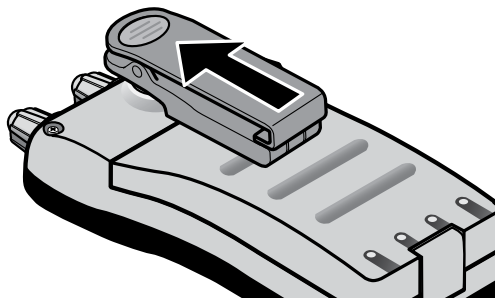

To remove the belt clip:

1. Rotate the clip so that the finger indentation is towards the bottom of the radio.
2. Slide the clip up until it comes free of the anchor post.

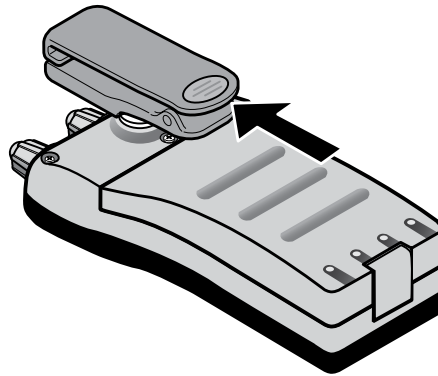
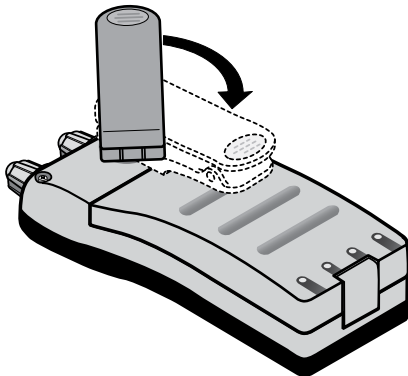

## Using Your Radio

### Changing the volume

To increase the speaker volume, turn the **Volume-Power** knob clockwise; turn it counter-clockwise to decrease the volume.

### Setting the squelch level

The squelch feature reduces static on the speaker by filtering out any background channel noise. At the lowest squelch level, the speaker plays all signals, including any channel noise.

Setting the squelch level higher filters out noise and lets only actual radio transmissions through.

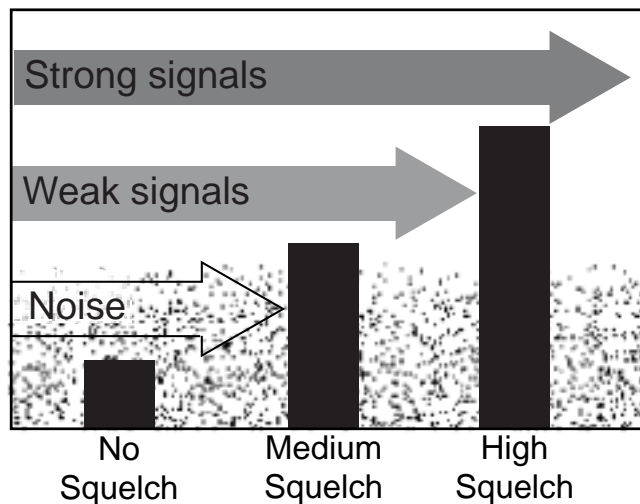

While listening to a channel, adjust the **SQUELCH** knob until the noise is filtered and you can hear only the transmission. If you switch to a channel with a lot of noise or a weak transmission, you may need to readjust the squelch level again.

**Note:** Setting the squelch level too high may prevent you from hearing weaker transmissions. If you are having difficulty hearing a transmission, try setting the squelch level lower.

### Changing the channel

Press the **Channel Up** and **Channel Down** buttons briefly to scroll through the channels one channel at a time. Press and hold the **Channel Up** or **Channel Down** button to quickly scroll through the channels.

## Making a transmission

Select the channel you want to transmit on, then press and hold the **Push to Talk** button. Release the **Push to Talk** button when you're finished talking to let the other party respond.

- To prevent stuck microphone problems or situations where the **Push to Talk** button is pushed accidentally, the radio limits your talk time to 5 minutes in a single transmission.
- For the best sound quality, hold the microphone about two inches away from your mouth.
- See the channel lists starting on page 19 for a list of receive-only channels.

## Boosting the transmission power

In most situations, the 1 Watt transmission power is all you need. If you find yourself far away from other stations and have trouble getting a response, you may need to boost the transmission power from 1 Watt to 2.5 Watts or 5 Watts:

- Press the **1/5W-2.5W** button to switch from 1 Watt to 5 Watts. Press the button again to switch back to 1 Watt.
- To switch to 2.5 Watts, press and hold the **1/5W-2.5W** button for about two seconds. Press and hold the button again to switch back to 1 Watt or 5 Watts (whichever you were on when you switched to 2.5 Watts).
- The transmit power remains at the new setting until you change it again. The transmit power icon always shows the current transmission power.

**Note:** Don't forget to change the transmission setting back to 1 Watt when you move close to other stations.

- Some channels (for example, channels 13 and 67) limit the transmission power to 1 Watt. When you tune to a limited-power channel, the radio automatically switches to 1 Watt. See the channel lists starting on page 19 for a list of power-restricted channels.

## Setting the UIC channel mode

The radio comes preset to use the channels assigned for the US. If your current area uses Canadian or international channel assignments, press the **UIC-Lock** key to rotate through the US, Canadian, and international channels.

## Maintenance and Troubleshooting

Due to its rugged design, the MHS75 requires very little maintenance. However, it is a precision electronic instrument, so you should follow a few precautions:

- If the antenna has been damaged, do not transmit except in an emergency situation. Transmitting with a defective antenna may cause further radio damage.
- You are responsible for continued FCC technical compliance of your radio.
- You should arrange for periodic performance checks with your Uniden dealer.

## Common questions

Problem	Things to Try
The radio won't turn on.	Charge the battery.
The power LED on the charger doesn't turn on.	<ul style="list-style-type: none"><li>– Replace the fuse inside the charger. (Contact customer service for a replacement fuse and instructions on changing it.</li><li>– Replace the battery.</li></ul>
The radio won't transmit.	<ul style="list-style-type: none"><li>– Make sure you are not in weather or scan mode.</li><li>– Make sure you are not trying to transmit on a receive-only channel or transmit at the wrong power level for this channel (see the channel lists starting on page 19).</li><li>– Check the battery power level; if it's low, charge the battery before trying to transmit.</li><li>– Make sure the duration of each transmission is less than 5 minutes.</li></ul>

Problem	Things to Try
I can't hear anything from the speaker.	Adjust the squelch level; it is probably too high.
Noise comes out of the speaker all the time	Adjust the squelch level; it is probably too low.
I can transmit, but no one can hear me.	Check your UIC channel settings: does the area you are in use different channel assignments?
I'm not getting hazard alerts.	Make sure Weather Alert Watch is turned on.
The display flashes, and I don't know why.	The channel number on the display will flash if the radio is in a watch mode or in scan mode. Try turning off scanning, Weather Alert Watch, Triple Watch, or Dual Watch (see page 6).
Where can I find my radio's serial number?	The serial number is on a plate inside the battery compartment.

## Specifications

General	
Channels	All US/International/Canada marine channels
	10 Weather channels
Freq. Control	PLL
Freq. Tol.	Transmit: 1.5 PPM (at 25°C) Receive: 1.5 PPM (at 25°C)
Oper. Temp.	-4°F (-20°C) to +122°F(+50°C)
Antenna	Flexible Whip
Microphone	Built-in Electret type
Display	Liquid Crystal Display
Speaker	8Ω 0.5 Watt
Power Source	Rechargeable Lithium Ion Battery 7.4V 1040 mAh
Size (without antenna)	4.57 (H) x 2.49 (W) x 1.53 (D) inch 116.2 (H) x 63.3 (W) x 39 (D) mm
Weight	10.2 oz (290g) (w/battery and antenna)

<b>Transmitter</b>	
Frequency Range	156~158 MHz
Frequency Stability	±10 PPM
Power Output	1.0 W & 2.5W & 5W
Spurious Emissions	70 dBc
Current Drain	1400 mA (5W)
<b>Receiver</b>	
Type	Double Conversion Super Heterodyne Phase Locked Loop system for Local Oscillator
Frequency Range	156~164 MHz
Sensitivity	0.20 μV for 12dB SINAD
Squelch Sensitivity	Threshold 0.12μV
Audio Frequency Response	+5 dB @ 500 Hz; -6 dB @ 2000Hz
Adjacent Channel Selectivity	75 dB @ ±25 kHz
Audio Output Power	0.4 W @10% THD
Current Drain	Squelched: 55 mA; Max. Audio: 210 mA

## Channels and Frequencies

### US channel frequencies and names

US Marine Channels				
Ch	RX Freq	TX Freq	Status	Name
1A	156.050	156.050	Simplex	Vessel traffic system/commercial
5A	156.250	156.250	Simplex	Vessel traffic system/commercial
6	156.300	156.300	Simplex	Inter-ship safety
7A	156.350	156.350	Simplex	Commercial
8	156.400	156.400	Simplex	Commercial
9	156.450	156.450	Simplex	Non commercial
10	156.500	156.500	Simplex	Commercial
11	156.550	156.550	Simplex	Vessel traffic system
12	156.600	156.600	Simplex	Vessel traffic system
13	156.650	156.650	Simplex, 1W	Bridge to bridge

US Marine Channels				
Ch	RX Freq	TX Freq	Status	Name
14	156.700	156.700	Simplex	Vessel traffic system
15	156.750	Inhibit	Receive only	Environmental
16	156.800	156.800	Simplex	Distress, safety, and calling
17	156.850	156.850	Simplex, 1W	Govt maritime control
18A	156.900	156.900	Simplex	Commercial
19A	156.950	156.950	Simplex	Commercial
20	161.600	157.000	Duplex	Port operation
20A	157.000	157.000	Simplex	Port operation
21A	157.050	157.050	Simplex	Coast guard only
22A	157.100	157.100	Simplex	Coast guard
23A	157.150	157.150	Simplex	Coast guard only
24	161.800	157.200	Duplex	Marine operator
25	161.850	157.250	Duplex	Marine operator
26	161.900	157.300	Duplex	Marine operator
27	161.950	157.350	Duplex	Marine operator
28	162.000	157.400	Duplex	Marine operator
63A	156.175	156.175	Simplex	Vessel traffic system
65A	156.275	156.275	Simplex	Port operation
66A	156.325	156.325	Simplex	Port operation
67	156.375	156.375	Simplex, 1W	Bridge To Bridge
68	156.425	156.425	Simplex	Non Commercial
69	156.475	156.475	Simplex	Non Commercial
70	156.525	Inhibit	Receive only	Digital Selective Calling
71	156.575	156.575	Simplex	Non Commercial
72	156.625	156.625	Simplex	Non Commercial (Ship-Ship)
73	156.675	156.675	Simplex	Port Operation
74	156.725	156.725	Simplex	Port Operation
75	156.775	156.775	Simplex, 1W	Port Operation
76	156.825	156.825	Simplex, 1W	Port Operation
77	156.875	156.875	Simplex, 1W	Port Operation (Ship-Ship)
78A	156.925	156.925	Simplex	Non Commercial

US Marine Channels				
Ch	RX Freq	TX Freq	Status	Name
79A	156.975	156.975	Simplex	Commercial
80A	157.025	157.025	Simplex	Commercial
81A	157.075	157.075	Simplex	Coast Guard
82A	157.125	157.125	Simplex	Coast Guard
83A	157.175	157.175	Simplex	Government
84	161.825	157.225	Duplex	Marine Operator
85	161.875	157.275	Duplex	Marine Operator
86	161.925	157.325	Duplex	Marine Operator
87A	157.375	157.375	Simplex	Marine Operator
88A	157.425	157.425	Simplex	Commercial (Ship-Ship)

### Canadian channel frequencies and names

Canadian Marine Channels				
Ch	RX Freq	TX Freq	Status	Name
1	160.650	156.050	Duplex	Marine Operator
2	160.700	156.100	Duplex	Marine Operator
3	160.750	156.150	Duplex	Marine Operator
4A	156.200	156.200	Simplex	Canadian Coast Guard
5A	156.250	156.250	Simplex	Vessel Traffic System
6	156.300	156.300	Simplex	Inter-Ship Safety
7A	156.350	156.350	Simplex	Commercial
8	156.400	156.400	Simplex	Commercial
9	156.450	156.450	Simplex	Boater Calling Channel
10	156.500	156.500	Simplex	Commercial
11	156.550	156.550	Simplex	Vessel Traffic System
12	156.600	156.600	Simplex	Vessel Traffic System
13	156.650	156.650	Simplex, 1W	Bridge To Bridge
14	156.700	156.700	Simplex	Vessel Traffic System
15	156.750	156.750	Simplex, 1W	Environmental
16	156.800	156.800	Simplex	Distress, safety, calling
17	156.850	156.850	Simplex, 1W	State Control



Canadian Marine Channels				
Ch	RX Freq	TX Freq	Status	Name
18A	156.900	156.900	Simplex	Commercial
19A	156.950	156.950	Simplex	Canadian Coast Guard
20	161.600	157.000	Duplex, 1W	Port Operation
21A	157.050	157.050	Simplex	Canadian Coast Guard
22A	157.100	157.100	Simplex	Canadian Coast Guard
23	161.750	157.150	Duplex	Canadian Coast Guard
24	161.800	157.200	Duplex	Marine Operator
25	161.850	157.250	Duplex	Marine Operator
26	161.900	157.300	Duplex	Marine Operator
27	161.950	157.350	Duplex	Marine Operator
28	162.000	157.400	Duplex	Marine Operator
60	160.625	156.025	Duplex	Marine Operator
61A	156.075	156.075	Simplex	Canadian Coast Guard
62A	156.125	156.125	Simplex	Canadian Coast Guard
63A	156.175	156.175	Simplex	Port Operation
64	160.825	156.225	Duplex	Marine Operator
64A	156.225	156.225	Simplex	Port Operation
65A	156.275	156.275	Simplex	Port Operation
66A	156.325	156.325	Simplex, 1W	Port Operation
67	156.375	156.375	Simplex	Bridge To Bridge
68	156.425	156.425	Simplex	Non Commercial
69	156.475	156.475	Simplex	Non Commercial
70	156.525	Inhibit	Receive only	Digital Selective Calling
71	156.575	156.575	Simplex	Non Commercial
72	156.625	156.625	Simplex	Non Commercial
73	156.675	156.675	Simplex	Port Operation
74	156.725	156.725	Simplex	Port Operation
75	156.775	156.775	Simplex, 1W	Port Operation
76	156.825	156.825	Simplex, 1W	Port Operation
77	156.875	156.875	Simplex, 1W	Port Operation
78A	156.925	156.925	Simplex	Inter Ship

Canadian Marine Channels				
Ch	RX Freq	TX Freq	Status	Name
79A	156.975	156.975	Simplex	Inter Ship
80A	157.025	157.025	Simplex	Inter Ship
81A	157.075	157.075	Simplex	Canadian Coast Guard
82A	157.125	157.125	Simplex	Canadian Coast Guard
83	161.775	157.175	Duplex	Canadian Coast Guard
83A	157.175	157.175	Simplex	Canadian Coast Guard
84	161.825	157.225	Duplex	Marine Operator
85	161.875	157.275	Duplex	Marine Operator
86	161.925	157.325	Duplex	Marine Operator
87	157.375	157.375	Simplex	Port Operation
88	157.425	157.425	Simplex	Port Operation

### International channel frequencies and names

International Marine Channels				
Ch	RX Freq	TX Freq	Status	Name
1	160.650	156.050	Duplex	Marine operator
2	160.700	156.100	Duplex	Marine operator
3	160.750	156.150	Duplex	Marine operator
4	160.800	156.200	Duplex	Marine operator
5	160.850	156.250	Duplex	Marine operator
6	156.300	156.300	Simplex	Inter-ship safety
7	160.950	156.350	Duplex	Marine operator
8	156.400	156.400	Simplex	Commercial (ship-ship)
9	156.450	156.450	Simplex	Boater calling channel
10	156.500	156.500	Simplex	Commercial
11	156.550	156.550	Simplex	Vessel traffic system
12	156.600	156.600	Simplex	Vessel traffic system
13	156.650	156.650	Simplex	Bridge to bridge
14	156.700	156.700	Simplex	Vessel traffic system
15	156.750	156.750	Simplex, 1W	Environmental
16	156.800	156.800	Simplex	Distress, safety, calling

International Marine Channels				
Ch	RX Freq	TX Freq	Status	Name
17	156.850	156.850	Simplex, 1W	Govt maritime control
18	161.500	156.900	Duplex	Port operation
19	161.550	156.950	Duplex	Commercial
20	161.600	157.000	Duplex	Port operation
21	161.650	157.050	Duplex	Port operation
22	161.700	157.100	Duplex	Port operation
23	161.750	157.150	Duplex	Marine operator
24	161.800	157.200	Duplex	Marine operator
25	161.850	157.250	Duplex	Marine operator
26	161.900	157.300	Duplex	Marine operator
27	161.950	157.350	Duplex	Marine operator
28	162.000	157.400	Duplex	Marine operator
60	160.625	156.025	Duplex	Marine operator
61	160.675	156.075	Duplex	Marine operator
62	160.725	156.125	Duplex	Marine operator
63	160.775	156.175	Duplex	Marine operator
64	160.825	156.225	Duplex	Marine operator
65	160.875	156.275	Duplex	Marine operator
66	160.925	156.325	Duplex	Marine operator
67	156.375	156.375	Simplex	Bridge to bridge
68	156.425	156.425	Simplex	Non commercial
69	156.475	156.475	Simplex	Non commercial
70	156.525	Inhibit	Receive only	Digital Selective Calling
71	156.575	156.575	Simplex	Non commercial
72	156.625	156.625	Simplex	Non commercial
73	156.675	156.675	Simplex	Port operation
74	156.725	156.725	Simplex	Port operation
75	156.775	156.775	Simplex, 1W	Port operation
76	156.825	156.825	Simplex, 1W	Port operation
77	156.875	156.875	Simplex	Port operation (ship-ship)
78	161.525	156.925	Duplex	Port operation

International Marine Channels				
Ch	RX Freq	TX Freq	Status	Name
79	161.575	156.975	Duplex	Port operation
80	161.625	157.025	Duplex	Port operation
81	161.675	157.075	Duplex	Port operation
82	161.725	157.125	Duplex	Port operation
83	161.775	157.175	Duplex	Port operation
84	161.825	157.225	Duplex	Marine operator
85	161.875	157.275	Duplex	Marine operator
86	161.925	157.325	Duplex	Marine operator
87	157.375	157.375	Simplex	Marine operator
88	157.425	157.425	Simplex	Marine operator

### Weather channel frequencies and names

Channel	RX
WX01	162.5500
WX02	162.4000
WX03	162.4750
WX04	162.4250
WX05	162.4500
WX06	162.5000
WX07	162.5250
WX08	161.6500
WX09	161.7750
WX10	163.2750

## Regulations and Safety Warnings

**WARNING!** Read this information before using the radio.

### Maritime radio services operation

**Warning!** This transmitter will operate on channels/frequencies that have restricted use in the United States. The channel assignments include frequencies assigned for exclusive use of the U.S. Coast Guard, use in Canada, and use in international waters. Operation on these frequencies without proper authorization is strictly forbidden. See pages 28 through 32 for tables of the available channels and their uses. If you are still not certain which channels to use, see the FCC maritime radio page at the FCC website (<http://wireless.fcc.gov/marine/>) or contact the FCC Call Center at 1-888-CALL-FCC. For individuals requiring a license, such as commercial users, you should obtain a license application from your nearest FCC field office (for US users) or Industry Canada (for Canadian users).

### Basic radio guidelines

You should familiarize yourself with the rules on marine radios and be aware of which rules apply to your boat. Complete guidelines for all ship and marine radio types can be found at the US Coast Guard website under the topic Radio Info for Boaters (the direct link is <http://www.navcen.uscg.gov/marcomms/boater.htm>). Here are a few guidelines that affect nearly all boaters.

- If you have a VHF radio on your boat, you must maintain a watch on channel 16 (156.800 MHz) whenever the radio is not being used to communicate. Starting in 2004, if a radio is carried, it must be on and set to channel 16 whenever your boat is underway.
- If you hear a distress call, wait a few minutes to let a shore station or Coast Guard vessel respond. If no other station has responded after 5 minutes, you must respond to the distress call.

- Do not make false mayday or distress calls as a prank or to test your radio. (This is essentially like making a false 9-1-1 call; you may be subject to fines.)

### **FCC/Industry Canada information**

- Certification: FCC Part 80 or RSS-182
- Output Power: 5W
- Emission: 16K0F3E
- Transmitter Frequency Range: 156.025-157.425 MHz

This device complies with Part 80 of the FCC Rules, as well as Part 15 of the FCC Rules. Operation is subject to the condition that this device does not cause harmful interference.

Unauthorized changes or modifications to this equipment may void compliance with the FCC Rules. Any change or modification must be approved in writing by Uniden. Changes or modifications not approved by Uniden could void the user's authority to operate the equipment.

### **FCC RF exposure information**

In August 1996 the Federal Communications Commission (FCC) of the United States with its action in Report and Order FCC 96-326 adopted an updated safety standard for human exposure to radio frequency electromagnetic energy emitted by FCC regulated transmitters. Those guidelines are consistent with the safety standard previously set by both U.S. and international standards bodies. The design of the radio complies with the FCC guidelines and these international standards.

Never allow children to operate the radio without adult supervision and the knowledge of the following guidelines.

**WARNING!** It is up to the user to properly operate this radio transmitter to insure safe operation. Please adhere to the following:

- Use only the supplied or an approved antenna. Unauthorized antennas, modifications, or attachments could impair call quality, damage the radio, or violate FCC regulations.
- Do not use the radio with a damaged antenna. If a damaged antenna comes into contact with the skin, a minor burn may result. Please contact your local dealer for a replacement antenna.

**Body-worn Operation:** This device was tested for typical body-worn operations using the supplied belt-clip. To maintain compliance with FCC RF exposure requirements, body-worn operations are restricted to the supplied belt-clip. For hand-held operation, the radio should be held 1 inch from the user's face. The use of accessories that do not satisfy these requirements may not comply with FCC RF exposure requirements and should be avoided. For more information about RF exposure, please visit the FCC website at [www.fcc.gov](http://www.fcc.gov).

### **Lithium ion battery warning**

This equipment contains a rechargeable Lithium Ion battery. The rechargeable Lithium Ion battery contained in this equipment may explode if disposed of in a fire.

Do not short-circuit the battery.

Do not charge the rechargeable battery used in this equipment in any charger other than the one specified in the owner's manual. Using another charger may damage the battery or cause the battery to explode.

### **Li-Ion batteries must be recycled or disposed of properly.**

Avoid exposing the battery (whether attached to the radio or not) to direct sunlight, heated cars, or temperatures below -4°F (-20°C) or above +140°F (+60°C). Exposing the chemical contained within the battery pack to temperatures above +140°F (+60°C) may cause the battery to rupture, fail, or reduce performance.

In case of exposure to the cell contents, wash the affected area thoroughly, and seek medical attention.

## **Three Year Limited Warranty Statement**

**WARRANTOR:** UNIDEN AMERICA CORP. (“Uniden”)

**ELEMENTS OF WARRANTY:** Uniden warrants, for three years, to the original retail owner, this Uniden Product to be free from defects in materials and craftsmanship with only the limitations or exclusions set out below.

**WARRANTY DURATION:** This warranty to the original user shall terminate and be of no further effect 36 months after the date of original retail sale. The warranty is invalid if the Product is (A) damaged or not maintained as reasonable or necessary, (B) modified, altered, or used as part of any conversion kits, subassemblies, or any configurations not sold by Uniden, (C) improperly installed, (D) serviced or repaired by someone other than an authorized Uniden service center for a defect or malfunction covered by this warranty, (E) used in any conjunction with equipment or parts or as part of any system not manufactured by Uniden, or (F) installed or programmed by anyone other than as detailed by the Operating Guide for this product.

**STATEMENT OF REMEDY:** In the event that the product does not conform to this warranty at any time while this warranty is in effect, warrantor will repair the defect and return it to you without charge for parts, service, or any other cost (except shipping and handling) incurred by warrantor or its representatives in connection with the performance of this warranty. **THE LIMITED WARRANTY SET FORTH ABOVE IS THE SOLE AND ENTIRE WARRANTY PERTAINING TO THE PRODUCT AND IS IN LIEU OF AND EXCLUDES ALL OTHER WARRANTIES OF ANY NATURE WHATSOEVER, WHETHER EXPRESS, IMPLIED OR ARISING BY OPERATION OF LAW, INCLUDING, BUT NOT LIMITED TO ANY IMPLIED WARRANTIES OF MERCHANTABILITY**



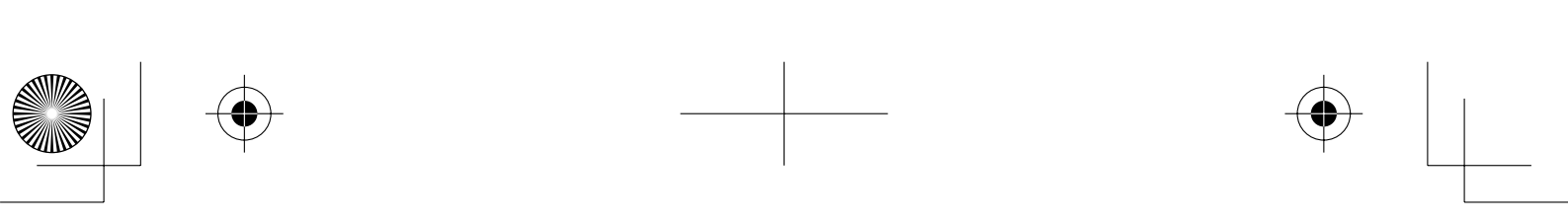

OR FITNESS FOR A PARTICULAR PURPOSE. THIS WARRANTY DOES NOT COVER OR PROVIDE FOR THE REIMBURSEMENT OR PAYMENT OF INCIDENTAL OR CONSEQUENTIAL DAMAGES. Some states do not allow this exclusion or limitation of incidental or consequential damages so the above limitation or exclusion may not apply to you.

**LEGAL REMEDIES:** This warranty gives you specific legal rights, and you may also have other rights which vary from state to state. This warranty is void outside the United States of America.

**PROCEDURE FOR OBTAINING PERFORMANCE OF WARRANTY:** If, after following the instructions in this Operating Guide you are certain that the Product is defective, pack the Product carefully (preferably in its original packaging). Include evidence of original purchase and a note describing the defect that has caused you to return it. The Product should be shipped freight prepaid, by traceable means, or delivered, to warrantor at:

**Uniden America Corporation  
Parts and Service Division  
4700 Amon Carter Boulevard  
Fort Worth, TX, 76155  
(800) 554-3988**