



# UIP200 User's Manual

Revision 1.0

© Uniden America Corp., May, 2004

This manual contains instructions for installing and operating your UIP200 SIP IP phone. It provides a description of the telephone's hardware, features, LCD displays, and explains setup, configuration, and basic operation. If you have any questions about the information in this document, please call our Customer Service Department at **1-800-648-4921** or visit us on the web at <http://bcs.uniden.com>.



---

## Table of Contents

---

|   |           |
|---|-----------|
| <b>Introduction .....</b>                             | <b>5</b>  |
| Document Conventions.....                             | 5         |
| Warnings, Cautions, Notes, and Timesavers.....        | 5         |
| Regulatory Information.....                           | 6         |
| FCC Part 15.....                                      | 6         |
| U.L. Compliance .....                                 | 6         |
| Industry Canada (ICES-003).....                       | 6         |
| Hearing-Aid Compatibility .....                       | 6         |
| Recording Conversations .....                         | 6         |
| What's New?.....                                      | 6         |
| Important Safety Considerations.....                  | 7         |
| Important Electrical Considerations .....             | 8         |
| The FCC Wants You to Know.....                        | 8         |
| AC Adapter .....                                      | 9         |
| Power over Ethernet (PoE).....                        | 9         |
| <br>  |           |
| <b>Product Description .....</b>                      | <b>10</b> |
| Features.....   | 10        |
| VoIP Specific Features.....                           | 10        |
| Operational Features.....                             | 11        |
| Control and Functions.....                            | 11        |
| Function Keys.....                                    | 12        |
| LED Status .....                                      | 12        |
| Specifications.....                                   | 12        |
| Physical Interface .....                              | 13        |
| Power Supply .....                                    | 13        |
| Speaker.....  | 13        |
| <br>  |           |
| <b>Installation and Basic Setup Instructions.....</b> | <b>14</b> |
| Wall-Mounting the Telephone.....                      | 14        |
| Connecting the Telephone .....                        | 15        |
| <br>  |           |
| <b>Basic Telephone Operations.....</b>                | <b>16</b> |
| Standby .....   | 16        |

---

|  |    |
|--|----|
| Making Calls .....                                     | 16 |
| Using the Handset .....                                | 16 |
| Using the Speakerphone or a Headset (Hands-free) ..... | 16 |
| Using On-Hook Dialing .....                            | 17 |
| Receiving Calls .....                                  | 17 |
| Adjusting the Volume .....                             | 17 |
| Changing the Handset Volume.....                       | 17 |
| Changing the Headset Volume.....                       | 18 |
| Changing the Speakerphone Volume .....                 | 18 |
| Changing the Ringer Volume.....                        | 18 |
| Transferring a Call .....                              | 19 |
| Call Waiting Operation.....                            | 19 |
| Hold 19  |    |

---

**Feature Operations ..... 20**

|   |    |
|---|----|
| Programmable and Fixed Function Keys..... | 20 |
| 1-Touch Dialing .....                     | 20 |
| 2 -Touch Dialing .....                    | 21 |
| DND .....                                 | 21 |
| Voice Message Access.....                 | 21 |
| Mute.....                                 | 22 |
| Dial (fixed key) .....                    | 22 |
| Emergency Proxy.....                      | 22 |

---

**Configuring the Telephone..... 23**

|   |    |
|---|----|
| Navigating the Menus .....                  | 23 |
| Speed Dial Sub-Menu .....                   | 23 |
| Programming a 1-Touch Number.....           | 23 |
| Clearing or Editing the 1-Touch Number..... | 24 |
| Programming the 2 Touch Number.....         | 24 |
| Clearing or Editing the 2-Touch Number..... | 25 |
| Phone Settings Sub-Menu.....                | 25 |
| Changing the LCD Contrast.....              | 25 |
| Changing the Display Language .....         | 25 |
| Adjusting the Date and Time.....            | 26 |
| Network Setting .....                       | 27 |
| View Info .....                             | 27 |

## **Figures in This Document**

|   |    |
|---|----|
| Figure 1 Attaching the Wall Mount Bracket.....  | 14 |
| Figure 2 Mount the Phone on the Wall Plate..... | 14 |
| Figure 3 LCD in standby mode.....               | 16 |
| Figure 4 LCD when a Call is Connected.....      | 16 |
| Figure 5 LCD display when Receiving a Call..... | 17 |

## **Tables in This Document**

|   |    |
|---|----|
| Table 1 Revision History.....                                 | 6  |
| Table 2 Control Keys and Their Functions.....                 | 11 |
| Table 3 LEDs and Their Meanings.....                          | 12 |
| Table 4 Fixed-Function Key and Programmable Key Defaults..... | 20 |
| Table 5 Configuration Menus and Their Functions.....          | 23 |

## Introduction

---

### Document Conventions

#### Warnings, Cautions, Notes, and Timesavers

This document uses particular conventions for warnings, cautions, notes and timesavers. Below is an example of these conventions and how they are used:

**WARNING**

*Warnings appear with the stop sign. They indicate there is extreme danger or a risk of injury if the instructions are not followed correctly. Some warnings are required by government regulation or company policy.*



**CAUTION**

*Cautions appear with the "slow" sign. They indicate there is a danger of damaging the equipment or causing a mission-critical problem if the instructions are not followed correctly. Some cautions are required by government regulation or company policy.*



**NOTE**

*Notes point out important and useful information that the user should remember, but there is no danger. Most notes are based on by suggestions from users or frequent questions to support personnel.*

---

---



**TIMESAVER**

*Timesavers are hints that will make things go a little faster. Most timesavers are suggestions from users that have worked well in the field.*

---

---

## Regulatory Information

### FCC Part 15

This product complies with the limits for a Class B computing device pursuant to Sub part B of Part 15 of FCC Rules.

### U.L. Compliance

This equipment complies with Underwriters Laboratories Standard U.L. 60950.

### Industry Canada (ICES-003)

This class B digital apparatus complies with Canadian ICES-003. Users should not attempt to make such connections themselves, but should contact the appropriate electric inspection authority, or electrician, as appropriate.

### Hearing-Aid Compatibility

The equipment is hearing-aid compatible.

### Recording Conversations

The act of monitoring or recording telephone conversations under certain circumstances may violate federal or state statutes. Consult your legal counsel prior to monitoring or recording any telephone conversation.

**CAUTION**  
*No repairs can be done by the customer! Attempting repairs will damage the equipment and void your warranty!*



## What's New?

This is the first release of documentation for this product.

*Table 1 Revision History*

| Revision | Publication Date | Changes                         |
|----------|------------------|---------------------------------|
| 1.0      | May 31, 2004     | First release of this document. |

## Important Safety Considerations

When using this product, basic safety precautions should always be followed to reduce the risk of fire, electrical shock and injury to persons, including but not limited to the following:

- Read and understand all instructions.
- Follow all warnings and instructions marked on the product.
- Unplug this product from the wall outlet and network connection before cleaning. Do not use liquid cleaners or aerosol cleaners. Use a dry cloth for cleaning.
- **Do not** use this product near water; for example, near a sink or in a wet area.
- **Do not** place this product on an unstable cart, stand, or table. The telephone can fall, causing serious damage to the unit.
- Slots and openings in the cabinet and the back or bottom are provided for ventilation. To protect the product from overheating, these openings must not be blocked or covered. This product should never be placed near or over a radiator or heat register. This product should not be placed in a built-in installation unless the proper ventilation is provided.
- This product should be operated only from the type of power source indicated on the marking label. If you are not sure of the type of power supply to your home, consult your dealer or local power company.
- **Do not** allow anything to rest on the power cord. Do not locate this product where the cord will be damaged by people walking on it.
- **Do not** overload wall outlets and extension cords, as this can result in the risk of fire or electrical shock.
- Never push objects of any kind into this product through cabinet slots, as they may touch dangerous voltage points or short out parts that could result in a risk of fire or electrical shock. Never spill liquid of any kind on the product.
- To reduce the risk of electric shock, do not disassemble this product. Contact qualified service personnel when some service or repair work is required. Opening or removing covers may expose you to dangerous voltages or other risks. Incorrect reassembly can cause electric shock when the appliance is subsequently used.
- Unplug this product from the wall outlet and network connection; servicing to be performed by qualified service personnel under the following conditions:
  1. When the power supply cord is damaged or frayed.
  2. If liquid has been spilled onto the product.
  3. If the product has been exposed to water or rain.
  4. If the product does not operate normally when following the operating instructions. (Adjust only those controls that are covered by the operating

instructions. Improper adjustment of other controls can result in damage, and will often require extensive repair work by a qualified technician.)

5. If the product has been dropped, or the cabinet has been damaged.
  6. If the product exhibits a distinct change in performance.
- Uniden works to reduce lead content in our PVC coated cords in our products and accessories.

**WARNING**

***The cords on this product and/or accessories contain lead, a chemical known to the State of California to cause birth defects or other reproductive harm. Wash hands after handling.***



## Important Electrical Considerations

Unplug all electrical appliances when you know an electrical storm is approaching. Lightning can pass through your household wiring and damage any device connected to it. This product is no exception.

**WARNING**



## The FCC Wants You to Know

Changes or modifications to this product not expressly approved by the party responsible for compliance could void the user's authority to operate the equipment.

This equipment has been tested and found to comply with the limits for a Class B digital device pursuant to part 15 of the FCC Rules. These limits are designed to provide reasonable protection against harmful interference in a residential installation. This equipment generates, uses and can radiate radio frequency energy and, if not installed and used in accordance with the instructions, and may cause harmful interference to radio communications. However, there is no guarantee that interference will not occur in a particular installation.

If this equipment does cause harmful interference to radio or television reception, which can be determined by turning the equipment off and on, the user is



encouraged to try to correct the interference by one or more of the following measures:

- Reorient or relocate the receiving antenna.
- Increase the separation between the equipment and the receiver.
- Connect the equipment into an outlet on a circuit different from that to which the receiver is connected.
- Consult the dealer or an experienced radio/TV technician for help.

## **AC Adapter**

The UIP200 is intended to be supplied by IPAD-532 a UL Listed direct plug-in power unit marked “Class 2” or “LPS” or “I.T.E. Power Supply” and rated 5VDC, 1.7A output. Connect the AC adaptor to a continuous outlet (i.e., one that is not controlled by a switch.)

Place the power cord where it will not create a trip hazard, or where it could become chafed or frayed, create a risk of fire or electrical shock.

## **Power over Ethernet (PoE)**

The UIP200 may obtain power via the LAN when a Power over Ethernet switch is used. Connect the category 5 RJ 45 cable to the LAN port only; the input is –48 VDC, 6.4 W.

Place the RJ 45 cable where it will not create a trip hazard, or where it could become chafed or frayed, create a risk of fire or electrical shock.

## Product Description

---

### Features

- 11 LED indicators (8 programmable keys, Headset/speaker, Hold, and Receive Signaling Lamp)
- 12-key dial pad
- 16 specific keys (Eight programmable keys, Menu, Cancel, Dial, Transfer, Headset/speaker, Hold, Volume Up/Down)
- Volume control for speaker, handset, headset and ringer
- 4 One-Touch speed dial numbers
- 10 Two-touch speed dial numbers
- Automatic Ringdown (Hotline feature)
- Call Waiting
- Call Transfer (Blind and Consultation)
- Do Not Disturb (DND)
- DTMF generation
- Hold, Mute, Redial
- Hands free talking via headset
- 2-line, 16-character alphanumeric LCD display
- Date and time display
- Call duration display
- On-hook dialing
- LCD contrast control
- Display Caller ID (Name & Number)
- Hands free talking via speakerphone

### VoIP Specific Features

The following features are specific to the VoIP function.

- SIP standard compliant (RFC 3261)
- Voice Codec: G.711 ( $\mu$ -Law and A-Law), G729A
- Acoustic Echo Cancellation (AEC) (G.165)
- DHCP or Static IP address Configuration

- Quality of Service (IEEE 802.1 p/q based and DiffServ)
- Jitter compensation
- 10/100 Base-T Ethernet Interface
- Additional 10/100 Base-T Ethernet Switch port for connecting a PC.

## Operational Features

- Terminal configuration
- Firmware update via TFTP
- Auto Configuration update using TFTP
- Remote Reboot using NOTIFY event message
- Password protection for configuration update

## Control and Functions

To make phone operations easier and to avoid user confusion, many required functions are already programmed into the fixed-function keys. There are 8 fixed function keys in the UIP200.

*Table 2 Control Keys and Their Functions*

| Key                | Situation  | Operation   |
|--------------------|--|---|
| HEADSET/SPEAKER    | On a call  | Turns speakerphone/headset on and off                         |
| HOLD               | On a call  | Places the remote party on Hold.                              |
| XFR/FLASH          | One caller is on the line                        | Transfers the call to another number                          |
|                    | Call waiting tone sounds                         | Flash   |
| DIAL               | Standby  | Redials the last called number                                |
|                    | Entering numbers                                 | Immediately sends entered digits.                             |
| MENU               | Standby  | Displays the main Setup menu                                  |
|                    | Within a sub-menu                                | Select  |
| CANCEL             | Manual configuration                             | Cancels configuration changes                                 |
|                    | When a phone number has dialed but not connected | Cancels the dialing sequence and returns the phone to standby |
|                    | When entering character strings or digits        | Deletes the whole character string or digits(s)               |
|                    | Setup menus                                      | Cancels the operation and returns to the previous menu.       |
| UP ▲ and<br>DOWN ▼ | On a call  | Adjusts volume  |
|                    | In the setup menu                                | Scrolls through options                                       |

## Function Keys

There are eight user programmable function keys in the UIP200. Each can be programmed to one of several functions, for example, 1-Touch Speed Dialing, Voice Message Access, Do Not Disturb, Mute, or 2-Touch Speed Dialing.

## LED Status

There are eleven LEDs on the UIP200 IP phone. Two LEDs are also the fixed-function keys **HOLD** and **HEADSET/SPEAKER**. These fixed-function keys illuminate to show the status of the function while it is used. Another LED, the Visual Ringer LED, notifies the user of an incoming call. The other eight LEDs are the programmable function keys; these keys illuminate when they are used.

*Table 3 LEDs and Their Meanings*

| LED                                  | LED On  | LED Blinking               | LED Off                                   |
|--------------------------------------|---|----------------------------|---|
| All LEDs                             | The phone has powered up and is initializing. | N/A                        | The phone has initialized.                |
| <b>HOLD</b>                          | N/A   | A call is on hold.         | N/A                                       |
| <b>HEADSET/SPEAKER</b>               | The speaker phone or headset is enabled.      | N/A                        | The speaker phone or headset is disabled. |
| <b>MUTE</b><br>(programmable button) | The mute function is enabled.                 | N/A                        | The mute function is disabled.            |
| <b>DND</b><br>(programmable button)  | Do Not Disturb mode is enabled.               | N/A                        | Do Not Disturb mode is enabled.           |
| <b>VISUAL RINGER</b>                 | A voice message is waiting.                   | There is an incoming call. | N/A                                       |



### **NOTE**

*If all 8 programmable keys remain illuminated, refer to Appendix A for troubleshooting steps.*

## Specifications

The following specifications apply to the physical interface, power supply, and speaker.

## Physical Interface

- PC connection 10/100 Base-T (RJ-45)
- LAN connection 10/100 Base-T (RJ-45)
- Handset connection (RJ-22) x 1
- Headset (Phone Jack  $\phi$ 2.5mm) X 1
- DC Jack (EIAJ Class2, Center +) X 1

## Power Supply

- Input to the phone from the power supply: 5 Vdc, 1.7 A (IPAD-532)
- Input to the phone from Power Over Ethernet: nominal -48 Vdc (-36 to -57)

## Speaker

- 8  $\Omega$  8W  $\phi$ 57mm

---

## Installation and Basic Setup Instructions

---

### Wall-Mounting the Telephone

The wall mount bracket is included with the UIP200. The wall mount bracket can be attached to the bottom of the UIP200, allowing the user to wall mount the telephone. The bracket can only be attached one way. Once the bracket is attached, the phone may be mounted over an existing wall plate.

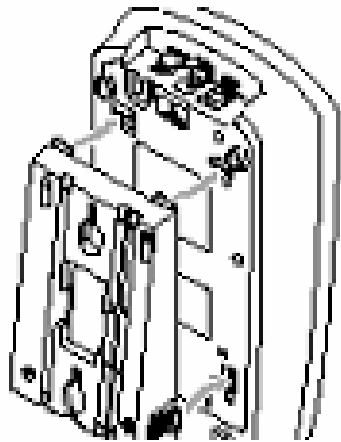
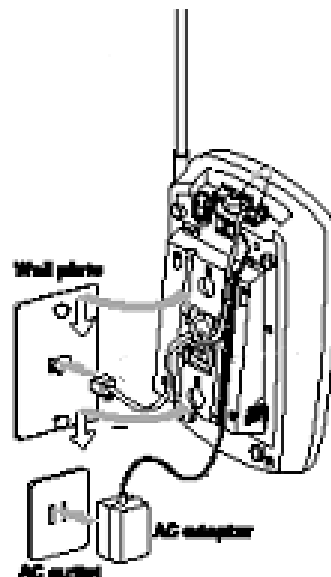

**Figure 1 Attaching the Wall Mount Bracket**

**Attach the wall mount bracket to the rear of the phone. Be sure the wide end of the bracket is at the bottom of the phone and the narrow end is at the top.**

### Figure 2 Mount the Phone on the Wall Plate

After attaching the wall mount bracket, place the bracket holes over the screws of a standard wall plate. Push the phone in and slide it down until it is securely seated on the plate.



## Connecting the Telephone

Before using the UIP200, you must connect the handset to the phone, connect the phone to the LAN network, and connect the phone to power.

**CAUTION**  
*If using Power over Ethernet, do not connect the AC power supply.*



- Step 1: Connect the handset to the handset port (RJ-22) located on the left side of the phone as viewed from the front of the phone.
- Step 2: Connect the Ethernet cable from the network to the port labeled *LAN* on the rear of UIP200.

**CAUTION**  
*Do not connect the UIP200 to a standard phone line.*



- Step 3: If the phone is not receiving power from the LAN, connect the AC adapter to the power jack located on the back of the phone and plug it in to a suitable power outlet.

---

## Basic Telephone Operations

---

### Standby

Standby mode is the state in which the UIP200 is on-hook, ready to make or receive calls. While the UIP200 is in standby mode, all LEDs are turned off and the current date, time and phone number are shown on the LCD (see Figure 3).

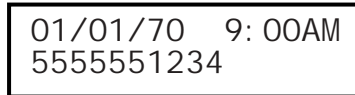

Figure 3 LCD in standby mode

### Making Calls

You can make calls using the handset or using the speakerphone or headset.

#### Using the Handset

- Step 1: Pick up the handset.
- Step 2: Dial the destination telephone number.
- Step 3: Press the **DIAL** key to initiate the connection immediately. If you wait approximately four seconds after you enter the last digit, the phone will automatically connect. After the call connects, the LCD will show the call duration timer (see Figure 4).

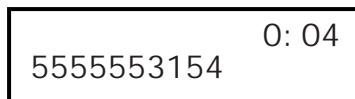

Figure 4 LCD when a Call is Connected

#### Using the Speakerphone or a Headset (Hands-free)

- Step 1: Press the **HEADSET/SPEAKER** key.



**NOTE:**

***If a headset is plugged in, pressing HEADSET/SPEAKER activates the headset. If no headset is present, it activates the speaker.***

---



- Step 2: Enter the destination telephone number.
- Step 3: Press the **DIAL** key to initiate the connection immediately. If you wait approximately four seconds after you enter the last digit enter, the phone will automatically connect.

## Using On-Hook Dialing

You can also enter telephone numbers before picking up the handset or activating the speakerphone (while the telephone is in standby mode).

- Step 1: Enter the destination number.
- Step 2: Pick up the handset or press **HEADSET/SPEAKER** to make the phone go off-hook.
- Step 3: Press the **DIAL** key to initiate the connection; if you wait approximately four seconds after you enter the last digit enter, the phone will automatically connect.

## Receiving Calls

When there is an incoming call, the **VISUAL RINGER LED** will flash and the LCD will display the number and name (if available) of the calling party. To answer the incoming call with the handset, simply pick up the handset. To answer an incoming call with the speakerphone or headset, leave the handset in the cradle and press the **HEADSET/SPEAKER** key.

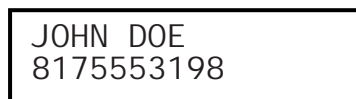

**Figure 5 LCD display when Receiving a Call**

## Adjusting the Volume

You can control the volume separately for the handset, the headset, the speakerphone, and the ringer.

### Changing the Handset Volume

- Step 1: Pick up the handset.
- Step 2: Press **▲ (UP)** or **▼ (DOWN)** to adjust the volume.

Step 3: When you reach the volume level you want, wait for 2.5 seconds.

Step 4: The new volume setting is saved.

### **Changing the Headset Volume**

Step 1: Plug in the headset.

Step 2: Press the **HEADSET/SPEAKER** key.

Step 3: Press **▲ (UP)** or **▼ (DOWN)** to adjust the volume.

Step 4: When you reach the volume level you want, wait for 2.5 seconds.

Step 5: The new volume setting is saved

### **Changing the Speakerphone Volume**

Step 1: If a headset is plugged into the phone, unplug the headset.

Step 2: Press the **HEADSET/SPEAKER** key.

Step 3: Press **▲ (UP)** or **▼ (DOWN)** to adjust the volume.

Step 4: When you reach the volume level you want, wait for 2.5 seconds.

Step 5: The new volume setting is saved.

### **Changing the Ringer Volume**

Step 1: Be certain that the phone is in standby (i.e., the handset is in the cradle and the **HEADSET/SPEAKER** key is not pressed).

Step 2: Press **▲ (UP)** or **▼ (DOWN)** to adjust the volume.

Step 3: When you reach the volume level you want, wait for 2.5 seconds.

Step 4: The new volume setting is saved.

## Transferring a Call

The steps below represent the most common method of transferring a call. Please note that the transfer operation may work differently with different systems.

- Step 1: During a call, press the **XFR/FLASH** key. This puts the current call on hold, and you will hear a dial tone.
- Step 2: Dial the number you wish to transfer the call to; you can transfer a call to any number, even one outside of your network.
- Step 3: If you do not want to wait for the other party to answer (a blind transfer), hang up the phone.
- Step 4: If you wait for the other party to answer, you can speak with the other party before hanging up the phone and transferring the call.

## Call Waiting Operation

- Step 1: If the call-waiting feature is enabled, you will hear a call waiting tone when another call comes in while you are on the line.
- Step 2: Press the **XFR/FLASH** key. This puts the current call on hold and allows you to speak with the new caller.
- Step 3: You can switch between the calls by pressing the **XFR/FLASH** key.



**NOTE:**

***If you disconnect one party, you will hear a fast ring, indicating there is another call waiting. You can reconnect by going off-hook again.***

---

---

## Hold

During a conversation, you can put the other party on hold by pressing the **HOLD** key. The **HOLD** key will blink continuously, and the LCD will display the duration timer and phone number of the party on hold. After 360 seconds (six minutes), an alert tone will sound to let you know the caller has been holding for a long time. To return to the call, press the **HOLD** key again.

## Feature Operations

### Programmable and Fixed Function Keys

There are eight programmable function keys and eight fixed functions keys in the UIP200. Programmable function keys can be assigned to any one of the available functions: One-touch speed dial, Two-touch speed dial, DND, Voice Message Access (VMA) or Mute. The programmable keys also act as LEDs to indicate the status of the assigned function.

**Table 4 Fixed-Function Key and Programmable Key Defaults**

| Key                  | Operation            |
|----------------------|----------------------|
| Programmable key 1-4 | One-Touch Dialing    |
| Programmable key 5   | Two-Touch Dialing    |
| Programmable key 6   | Do Not Disturb       |
| Programmable key 7   | Voice Message Access |
| Programmable key 8   | Mute (microphone)    |

#### 1-Touch Dialing

Programmable Keys 1 through 4 come pre-programmed with 1-Touch dialing feature. To use the 1-Touch dialing feature, you must program a phone number to one of the 1-touch programmable keys (see *Programming a 1-Touch Number* on page 23). (1-Touch dialing keys do not illuminate to indicate their state).

#### **1-Touch Dialing–Off-Hook Operation**

- Step 1: Pick up the cradle or press the **HEADSET/SPEAKER** key.
- Step 2: Select the appropriate **1-TOUCH** key. If you programmed the **DIAL** key as part of the number, the phone will start connecting immediately; otherwise, connection will start the after approximately 4 seconds.

#### **1-Touch Dialing–On-Hook Operation**

- Step 1: Press the desired **1-TOUCH** key.
- Step 2: Pick up the cradle or press the **HEADSET/SPEAKER** key. If you programmed the **DIAL** key as part of the number, the phone will start connecting immediately; otherwise, connection will start the after approximately 4 seconds.

## 2 -Touch Dialing

Users can make calls by pressing a key that has been previously programmed for two-touch dial and then pressing one of the number keys (**0** through **9**) on the dial pad. This combination allows you to program up to 10 numbers for 2-touch dialing. To use the 2-touch dialing feature, you must program a phone number to one of the 2-touch dialing number keys (see *Programming the 2 Touch Number* on page 24). (The 2-Touch dialing keys do not illuminate to indicate their state).

### **2-Touch Dialing–Off-Hook Operation**

- Step 1: Pick up the cradle or press the **HEADSET/SPEAKER** key.
- Step 2: Press the **2-TOUCH** key.
- Step 3: Select the desired 2-touch dialing number (**0-9**). If you programmed the **DIAL** key as part of the number, the phone will start connecting immediately; otherwise, connection will start the after approximately 4 seconds.

### **2-Touch Dialing–On-Hook Operation**

- Step 1: Press the **2-TOUCH** key.
- Step 2: Select the desired 2-touch dialing number (**0-9**).
- Step 3: Pick up the cradle or press the **HEADSET/SPEAKER** key. If you programmed the **DIAL** key as part of the number, the phone will start connecting immediately; otherwise, connection will start the after approximately 4 seconds.

## DND

Programmable Key 6 comes pre-programmed with Do Not Disturb (DND). When DND is activated, your station will appear busy to any callers. The phone will not ring on an incoming call, nor will it flash the **VISUAL RINGER LED**. When the DND feature is activated, the **DND LED** remains on.

To activate the DND feature, simply press the **DND** key. To deactivate the DND feature, press the **DND** key again.

## Voice Message Access

Programmable Key 7 comes pre-programmed with the Voice Message Access feature. The VMA feature provides one-touch access to your voice mailbox. When

a new voice message arrives, the **VISUAL RINGER** LED illuminates to notify you that a new message is waiting. To access your voice mail, follow the steps below:

- Step 1: Pick up the cradle or press the **HEADSET/SPEAKER** key.
- Step 2: Select the appropriate **1-TOUCH** key. If you programmed the **DIAL** key as part of the number, the phone will start connecting immediately; otherwise, connection will start the after approximately 4 seconds.

## **Mute**

Programmable Key 8 is pre-programmed as the **MUTE** key. During a call, you can press **MUTE** to disable the microphone on the handset, speakerphone or headset. While the Mute feature is activated, the **MUTE** LED remains on. To deactivate the Mute feature, press the **MUTE** key again.

## **Dial (fixed key)**

The **DIAL** key sends dialed digits without the usual four-second delay. The **DIAL** key may be entered while programming a speed dial number to eliminate the delay when speed dialing.

## **Emergency Proxy**

The UIP200 provides an Emergency Proxy feature that allows the user to access a SIP Emergency Proxy Server with pre-defined 2-digit dial plan. To execute a call via the emergency proxy dial the two digit prefix followed by the number.

## Configuring the Telephone

The main configuration menu is the *Setup* menu. This menu consists of five submenus that allow you to configure and display information about the UIP200. Table 5 shows the available menus and their uses.

**Table 5 Configuration Menus and Their Functions**

| Menu                   | Used To  |
|------------------------|--|
| <i>Speed Dial</i>      | Configure 1-Touch and 2-Touch Speed Dial numbers                           |
| <i>Phone Setting</i>   | Set terminal specific features such as LCD contrast, Language, Date & Time |
| <i>Network Setting</i> | Available to the administrator only  |
| <i>View Info</i>       | Display the telephone IP address and firmware version.                     |
| <i>Unlock Config</i>   | Available to the administrator only  |

### Navigating the Menus

The following information will help you understand the interface for the configuration menus.

- Press the **MENU** key to access the *Setup* menu.
- Use the **▲** and **▼** keys to scroll through the menu choices.
- When the desired menu option is highlighted, press the **MENU** key again to select the highlighted option.
- Press the **CANCEL** key to return to the previous screen.
- When a setting is successfully changed, you will hear a long beep. If an error occurs, you will hear a series of short beeps.
- If no key is pressed for 60 seconds during any menu operation, the phone will cancel menu operation and return to standby mode.

### Speed Dial Sub-Menu

The *Speed Dial* sub-menu is the first item inside the *Setup* main menu. You will use this menu to program or edit 1-touch and 2-touch speed dial numbers.

#### Programming a 1-Touch Number

Step 1: Press the **MENU** key to enter the *Setup* menu

- Step 2: Highlight the *Speed Dial* sub-menu and press **MENU** again.
- Step 3: Highlight the *1-Touch Dial* sub-menu and press **MENU**.
- Step 4: Press the unused 1-touch dial key you wish to program.
- Step 5: The phone will prompt you to enter a phone number. Enter a maximum of 32 digits. If you wish to eliminate the four-second delay before dialing, press the **DIAL** key at the end of the phone number. Press the **CANCEL** key at anytime to clear the entered digits and return to the *1-Touch Dial* sub-menu.
- Step 6: After entering the phone number, press **MENU**. You will hear a long beep, and the phone number is stored.

### **Clearing or Editing the 1-Touch Number**

- Step 1: Enter the *1-Touch Dial* sub-menu as describe above.
- Step 2: Press the already-programmed 1-touch dial key you wish to clear or edit.
- Step 3: If you want to edit the phone number, change the number and press the **MENU** key. If you want to clear the phone number, simply press the **MENU** key without editing the phone number.
- Step 4: You will hear a long beep confirming your changes to the 1-touch dial key.

### **Programming the 2 Touch Number**

- Step 1: Press the **MENU** key to enter the *Setup* menu
- Step 2: Highlight the *Speed Dial* sub-menu and press **MENU** again.
- Step 3: Scroll down to highlight the *2-Touch Dial* sub-menu and press **MENU**.
- Step 4: Press the 2-touch dial key (default is programmable key 6) and then press the dial key (**0-9**) you wish to program.
- Step 5: The phone will prompt you to enter a phone number. Enter a maximum of 32 digits. If you wise to eliminate the four-second pause before dialing, press the **DIAL** key at the end of the phone number. Press the **CANCEL** key at anytime to clear the entered digits and return to the *2-Touch Dial* sub-menu.
- Step 6: After entering the phone number, press **MENU**. You will hear a long beep, and the phone number is stored.



## Clearing or Editing the 2-Touch Number

- Step 1: Enter the *2-Touch Dial* sub-menu as describe above.
- Step 2: Press the 2-touch dial key (default is programmable key 6) and then press the already-programmed dial key (0-9) you wish to clear or edit.
- Step 3: If you want to edit the phone number, change the number and press the **MENU** key. If you want to clear the phone number, simply press the **MENU** key without editing the phone number.
- Step 4: You will hear a long beep confirming your changes to the 2-touch dial key.

## Phone Settings Sub-Menu

There are a total of six sub-menus inside the *Phone Settings* sub-menu. You can only access the *LCD Contrast*, *Adjust Time* and *Language* sub-menus. The *Preferred Codec*, *Factory Reset* and *Auto Config* sub-menus are available to administrators only.

### Changing the LCD Contrast

The *LCD Contrast* sub menu allows the user to configure the contrast setting of the LCD display.

- Step 1: Press the **MENU** key to enter the *Setup* menu
- Step 2: Scroll down to highlight the *Phone Settings* sub-menu and press **MENU** again.
- Step 3: Highlight the *LCD Contrast* sub-menu and press **MENU**.
- Step 4: Use the ▲ and ▼ keys to set the LCD display to the desired contrast.
- Step 5: When the LCD display reaches the desired contrast level, press **MENU** to save the setting. Press the **CANCEL** key to exit the sub-menu without saving.

### Changing the Display Language

You can set the language of the display to English, French, or Spanish.

- Step 1: Press the **MENU** key to enter the *Setup* menu

- Step 2: Scroll down to highlight the *Phone Settings* sub-menu and press **MENU** again.
- Step 3: Highlight the *Language* sub-menu and press **MENU**.
- Step 4: Use the **▲** and **▼** keys to scroll through the available languages.
- Step 5: When the LCD display shows the desired language, press **MENU** to save the setting. Press the **CANCEL** key to exit the sub-menu without saving.

## Adjusting the Date and Time

- Step 1: Press the **MENU** key to enter the *Setup* menu
- Step 2: Scroll down to highlight the *Phone Setting* sub-menu and press **MENU** again.
- Step 3: Highlight the *Adjust Time* sub-menu and press **MENU**. The phone will prompt you to edit the year.
- Step 4: If necessary, use the number keys to change the year and press **MENU**. The phone will prompt you to edit the month.
- Step 5: If necessary, use the number keys to change the month and press **MENU**. The phone will prompt you to edit the day.
- Step 6: If necessary, use the number keys to change the day and press **MENU**. The phone will prompt you to edit the hour.
- Step 7: If necessary, use the number keys to change the hour and press **MENU**. The phone will prompt you to edit the minutes.
- Step 8: If necessary, use the number keys to change the minutes and press **MENU**. The phone will then display *Enable DST*.
- Step 9: If your local community observes Daylight Savings Time (DST), select **ENABLED**. If your community does not observe DST, select **DISABLED**. Select the correct setting and press **MENU**. The phone will prompt you to set the GMT Offset.
- Step 10: Use the number keys to set the number of hours your local time zone differs from Greenwich Mean Time or GMT (also called Zulu Time or Universal Time/UT). For example, Eastern Standard Time in the US is 5 hours behind GMT, so you would enter the GMT offset as -5 if you lived in the EST time zone.
- Step 11: Press **MENU** to save the date and time setting. You will hear a long confirmation beep. Press the **CANCEL** key to exit the sub-menu without saving.



**NOTE:**  
***The local date and time can also be derived from the Date Header field in the response to a register request. User should set time to local time not GMT time.***

---

## Network Setting

The *Network Setting* sub-menu is used to assign network settings such as the *IP Address*, *Subnet Mask* and *Default Gateway*. All sub-menus under *Network Setting* are password protected and can be altered only by an administrator. Users may view the information but not change it.

## View Info

The *View Info* sub-menu allows users to view the IP address and firmware version.

- Step 1: Press the **MENU** key to enter the *Setup* menu
- Step 2: Scroll down to highlight the *View Info* sub-menu and press **MENU** again.
- Step 3: The phone will display the current firmware version and IP address of the terminal.
- Step 4: Press the **CANCEL** key to exit the sub-menu.