

**On-Premises
Soft Mount Washer-Extractors**

UniMac

18 lb (8 kg) Washer-Extractor
25 lb (11 kg) Washer-Extractor
35 lb (16 kg) Washer-Extractor
55 lb (25 kg) Washer-Extractor
75 lb (34 kg) Washer-Extractor
100 lb (45 kg) Washer-Extractor
135 lb (61 kg) Washer-Extractor
165 lb (75 kg) Washer-Extractor



Expert Solutions from the Laundry Experts

UniMac

Take a moment and step into the world of high tech product engineering where UniMac washer-extractors are designed with innovative features that command top performance, and durable steel construction that will stand the test of time. At UniMac, washer-extractors are considered more than just laundry equipment. They are key players in the success of commercial laundry facilities and as such must continuously achieve high levels of efficiency, quality and durability. UniMac has always maintained a standard of excellence in washer-extractor manufacturing that is recognized around the world. With over 50 years of engineering expertise you can be assured that you are getting the best washer-extractors on the market that will meet your needs now and in the future.

Tuned Suspension

Heavy-duty coil springs and strategically placed shock absorbers result in a tuned suspension system that absorbs out-of-balance load vibrations. The tuned suspension on UniMac

softmount models does

not require special foundations.

Strategically placed center of gravity and mass weight placement aid in controlling movement and results in a reduction of force transferred to floor.

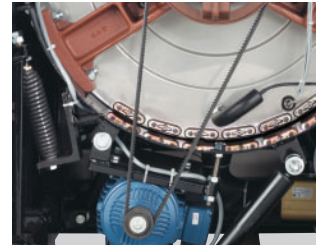

UX55 model shown.

High Tech Intelligent Drive System

The state-of-the-art *Intelligent Drive* provides flexibility and contributes to lower operating costs. The *Intelligent Drive* actually senses the speed (RPM) of the washer allowing extreme accuracy even when the washer is reaching and maintaining high extraction speeds.

The *Intelligent Drive* easily accommodates separate extraction speeds for blends, blankets and spreads or heavy cotton towels. It is like having a custom designed machine for each linen type. Combine this flexibility with energy savings from the variable frequency drive to get the most from your investment.



Shown with Programming Tool.

High Speed Extract

The higher the G-force during extraction, the lower the water retention of the fabrics being processed. 400+ G-force* will reduce the gas or electricity used during the drying process by as much as 40% over 85 G-force extract washers. This results in reduced drying and finishing time, reduced linting and extended linen life. High speed extraction can also eliminate preconditioning of items to be ironed, saving energy while increasing production.

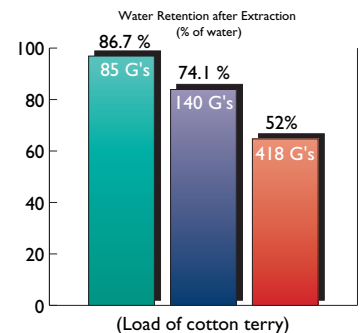

*UX55 model

Advanced Computer Control

UniMac's state-of-the-art computer control provides all the features you need to make your on-premises laundry operation efficient with the linen care performance you demand.



Operation Flexibility

The extremely flexible and easy to use control offers 39 pre-programmed settings with a maximum of 99 total programs. A variety of specialized needs can be met with the advanced computer control.

Programming options include:

- Overnight soak to assist with stain removal
- Precise temperature controlled fills
- Thermal cool-down for complete control of water temperature for optimal chemical performance, wrinkle control and longer linen life

ProgressDisplay™

The easy to read digital text messaging, ProgressDisplay™ provides you with immediate feedback on every step in the washing process.



This feature is great for:

- Improving scheduling in your laundry operation
- Informing multiple operators of workflow
- Training new employees

Laundry Room Management

The cycle counter function assists management in monitoring proper cycle use and efficient use of time by laundry operators. The total hours run function allows management to properly schedule routine maintenance.

- Number of cycles
- Number of hours the machine has been operated

Value For Your Money

- Water reuse capable
- Ozone capable
- Three water inlets standard (18-75 lb models)
- Four water inlets standard (100-165 lb models)

Compact Design

Our unique compact design uses 34% less floor space than some competitor's models, giving our customers more room to manage their laundry.

18-55 lb models fit through a standard 36" door.

UniMac washers require 34% less space than the leading competitor

- UniMac Equipment
- Competitor Equipment

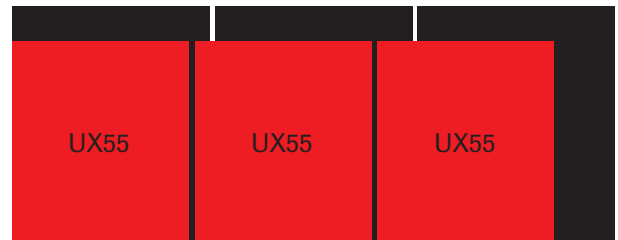

Multi-Faceted Supply Dispenser

The state-of-the-art liquid supply system for laundry chemicals offers convenience and dependability. It is factory installed for easy connection to the central liquid supply system providing six supply signals. For powder supplies, smaller models have three flush-down compartments mounted on the top of the washer. Larger models use removable cups. Laundry chemicals are mixed safely with water prior to coming in contact with fabrics.



Heavy-Duty Bearings and Seals

UniMac washer-extractors use heavy-duty precision bearings that are permanently lubricated for trouble-free operation. The double lip seals isolate the bearings from water and chemicals. Larger models use an automated lubrication system for ease of maintenance.

Five-Year Limited Parts Warranty

A five-year limited warranty is issued on the frame, basket, shaft, bearings and seals if failure or breakage should occur during normal operation due to defects in material or workmanship that would prohibit its further use. A three-year warranty is also issued to the original purchaser on all other parts.



Specifications

	UX18	UX25	UX35	UX55	UX75	UX100	UX135	UX165
Capacity (lb/kg)	18 (8)	25 (11)	35 (16)	55 (25)	75 (34)	100 (45)	135 (61)	165 (75)
Width (in/mm)	26" (660)	26" (660)	30.8" (783)	35.4" (900)	41.8" (1060)	47.3" (1200)	47.3" (1200)	51.2" (1300)
Depth (in/mm)	30.7" (780)	34.3" (870)	37.8" (960)	40" (1016)	46" (1168)	52.4" (1330)	59.1" (1500)	63.8" (1621)
Height (in/mm)	40.6" (1031)	40.6" (1031)	47" (1194)	60.8" (1544)	61.4" (1560)	75.6" (1920)	75.6" (1920)	82.7" (2100)
Cylinder Diameter (in/mm)	20.9" (530)	20.9" (530)	25.6" (650)	29.5" (750)	33.5" (850)	38.6" (980)	38.6" (980)	43.1" (1095)
Cylinder Depth (in/mm)	13.6" (345)	17.3" (440)	19.7" (500)	20.9" (530)	21.1" (537)	23.5" (597)	30.5" (775)	30.5" (775)
Cylinder Volume (cu.ft/liter)	2.7 (76)	3.4 (97)	5.9 (167)	8.3 (234)	10.8 (305)	15.9 (451)	20.7 (585)	25.8" (731)
Door Opening Size (in/mm)	11.8" (300)	11.8" (300)	11.8" (300)	15.6" (395)	15.6" (395)	19.7" (500)	19.7" (500)	24.5" (622)
Door Bottom to Floor (in/mm)	11" (279)	11" (279)	15.6" (395)	22" (559)	22" (559)	25.5" (648)	25.5" (648)	28" (711)
Wash Speed (rpm)	10-50	10-50	10-50	10-50	10-50	10-50	10-50	10-50
Distribution Speed (rpm)	82	82	74	69	65	61	61	100
Extract Speed (rpm)	85-1000	85-1000	100-1000	250-1000	250-1000	250-800	250-800	250-750
Extract G-Force (rpm)	19-296	19-296	23-363	26-418	30-475	34-350	34-350	344
Water Inlet Conn. (in/mm)	3 x .75 (19)	3 x .75 (19)	3 x .75 (19)	3 x .75 (19)	3 x .75 (19)	4 x .75 (19)	4 x .75 (19)	4 x .75 (19)
Steam Inlet Conn. (in/mm)	.375 (9.5)	.375 (9.5)	.375 (9.5)	.375 (9.5)	.375 (9.5)	.375 (9.5)	.375 (9.5)	.375 (9.5)
Drain Connection Size (in/mm)	2" (51)	2" (51)	2" (51)	3" (75)	3" (75)	3" (75)	3" (75)	4" (102)
Motor Size (HP/kw)	1 (.75)	1 (.75)	2 (1.5)	4 (3)	5.25 (4)	7.4 (5.5)	10 (7.5)	15 (11.5)
Voltage/Hz/Phase Non-heat Circuit Breaker-FLA	200-240/50-60 1/3 15-6	200-240/50-60 1/3 15-6	200-240/50-60 1/3 15-12	200-240/50-60 1/3 15-12	200-240/50-60/3 20-12	200-240/50-60/3 25-17	200-240/50-60/3 30-17	200-240/50-60/3 40-25
Voltage/Hz/Phase* Elect. heat Circuit Breaker-FLA	200-240/50-60/3 30-28	200-240/50-60/3 30-29	200-240/50-60/3 50-41	200-240/50-60/3 60-58	200-240/50-60/3 60-58	200-240/50-60/3 90-88	200-240/50-60/3 90-88	N/A
Voltage/Hz/Phase* Non-heat Circuit Breaker-FLA	380-415/50-60/3 16-6	380-415/50-60/3 16-6	380-415/50-60/3 16-12	380-415/50-60/3 16-12	380-415/50-60/3 16-12	380-415/50-60/3 20-17	380-415/50-60/3 25-17	380-415/50-60/3 25-20
Voltage/Hz/Phase Elect. heat Circuit Breaker-FLA	380-415/50-60/3 20-17	380-415/50-60/3 20-18	380-415/50-60/3 30-26	380-415/50-60/3 40-36	380-415/50-60/3 40-36	380-415/50-60/3 63-55	380-415/50-60/3 63-55	N/A
Voltage/Hz/Phase* Circuit Breaker-FLA	440-480/50-60/3 15-6	440-480/50-60/3 15-6	440-480/50-60/3 15-12	440-480/50-60/3 15-12	440-480/50-60/3 15-12	440-480/50-60/3 20-17	440-480/50-60/3 25-17	440-480/50-60/3 25-20
Shipping Dimensions (in/mm)	H: 44.9 (1140) W: 28.8 (732) D: 32.8 (832)	H: 48.8 (1240) W: 28.8 (732) D: 37.4 (950)	H: 51.6 (1310) W: 33.5 (850) D: 43.3 (1100)	H: 65 (1650) W: 40.2 (1020) D: 45.3 (1150)	H: 68.1 (1730) W: 45.7 (1160) D: 48.4 (1230)	H: 79.1 (2010) W: 51.2 (1300) D: 56.3 (1430)	H: 79.1 (2010) W: 51.2 (1300) D: 64.2 (1630)	H: 89.5 (2273) W: 55.4 (1407) D: 71.2 (1808)
Net Weight (lb/kg)	502 (236)	531 (241)	765 (347)	1247 (570)	1907 (865)	3351 (1520)	3626 (1645)	4630 (2100)
Shipping Weight (lb/kg)	624 (283)	639.5 (290)	1030 (467)	1380 (630)	2194 (995)	3741 (1697)	4017 (1822)	5181 (2350)
Agency Approvals	CE, ETL, ETLc	CE, ETL, ETLc	CE, ETL, ETLc	CE, ETL, ETLc	CE, ETL, ETLc	CE, ETL, ETLc	CE, ETL, ETLc	CE, ETL, ETLc

* Special order may require longer time, check with factory.

Voltages above or below listed may require a buck-boost transfer.

Due to continuous product improvement, design and specifications subject to change without notice. Features and certifications may vary by model.

© Copyright 2003 Alliance Laundry Systems LLC

Components:

1. Top Supply Compartment (18 - 75 lb)
2. Controls
3. Cold Water Inlet
4. Hot Water Inlet
5. Cold Water Inlet
6. Vacuum Breaker
7. Electrical Connection
8. Drain Outlet
9. Front Supply Compartment (100 - 165 lb)
10. Supply Inlet
11. Water Inlet for Supply Box (100 - 165 lb)

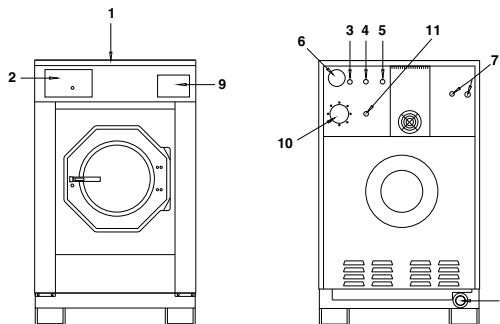

www.uniwash.com

Alliance Laundry Systems
Shepard Street, Ripon, WI 54971 Telephone: 1-800-587-5458

