

Contents

BEFORE YOU PROCEED READ THE OWNER'S MANUAL	P.2
SAFETY PRECAUTIONS	P.3
SUPPLIED EQUIPMENT, TOOLS AND BATTERIES	P.4
YOUR RTX-1 RADIO SYSTEM	P.5-9
THE RL4 CHASSIS	P.10
SETTING UP THE ANTENNA	P.12
SELECT ONE OF THE THREE BANDS (RED, ORANGE OR GREEN)	P.13
INSTALL BATTERIES	P.14
ATTACHING THE BODY TO THE CHASSIS	P.15-17
DECORATE YOUR VEHICLE BODY	P.18-20
TIGHTEN THE WHEELS ON YOUR VEHICLE	P.21
SETTING THE TRANSMITTER AND CAR BAND	P.21
PRE-RUN ROUTINE	P.21
RANGE TEST YOUR VEHICLE	P.22
RUNNING YOUR VEHICLE	P.22
TUNING YOUR VEHICLE	P.23-24
MAINTAINING YOUR VEHICLE	P.24
REPAIRING AND REPLACING WORN OR BROKEN PARTS	P.25-30
TROUBLESHOOTING	P.31
LIMITED WARRANTY	P.31
THE FCC WANTS YOU TO KNOW	P.32



BEFORE YOU PROCEED READ THE OWNER'S MANUAL

Thank you for purchasing a Radline RC vehicle! We are confident you will appreciate it's race ready design, precision performance and the ability to modify your stock vehicle to maximize speed and handling using Official Radline RC Performance Parts---available separately from your hobby dealer or Radline RC.

Radline RC offers you the ultimate radio control racing experience. This Owner's Manual is designed for use with Radline RC Elite Series Vehicles and contains the instructions you will need to assemble, operate and maintain your vehicle for years to come.

We know you are anxious to start racing---but it is very important that you take the time to read the Owner's Manual even if you are an experienced R/C racer.

Carefully read and follow all instructions in this and any other manuals included with your vehicle. Failure to follow the instructions will be considered abuse and or neglect and may void your factory warranty.

Your vehicle is designed to run on uneven or rough terrain. However dust, sand, water, and carpet fibers can lodge in the working parts of your vehicle and if not removed promptly, can damage it. We do not warranty your vehicle from damage due to outside elements including sand, dirt or water. This product is not a toy. It is not designed for users under 8 years old. You are responsible for the maintenance and safe operation of this vehicle.

Before operating your vehicle, please read this manual completely and examine your vehicle and transmitter. If for any reason you are not satisfied with your purchase, please return it to your hobby dealer before running your vehicle. Your hobby dealer cannot accept a vehicle or transmitter for return or exchange after it has been run.

SUPPORT

A highly experienced support team dedicated to making your RC experience totally enjoyable backs your Radline RC.

If you have any questions about your vehicle or the Radline RC radio system call the Radline RC Support toll free at : 1 866 486 4629 (toll free available in the U.S.A. Only all others please call 1 949 858 8409). Phone support is available Monday through Friday from 8:30AM to 5:00PM Pacific Time. Technical assistance is also available on line at www.radlinerc.com or by email at support@radlinerc.com.

Radline RC offers full-service repair to handle both warranty repair or replacement and out-of-warranty service. Radline RC recommends you purchase maintenance and repair parts as well as New Upgrade Performance Parts from your local hobby dealer. For those who do not have a Radline RC hobby dealer conveniently located to them, maintenance and repair parts, as well as New Upgrade Performance Parts, may be purchased directly from Radline RC by phone or online at www.BuyRadlinerc.com.

Do not hesitate to contact Radline RC for any product support needs. We are anxious to help.

SAFETY PRECAUTIONS

Radline RC wants you to enjoy your new vehicle and to operate it with care and safety. Failure to operate your vehicle in a safe and responsible manner may result in injury to yourself, others or property around you. You are responsible for following the guidelines mentioned here and to operate your vehicle safely.

- Do not run your vehicle on public roads or any area where you may interrupt pedestrian or vehicle traffic.
- Do not operate in a congested area or in crowds. Your vehicle can cause harm if it collides with any other person.
- Do not operate your vehicle with obstructed line of sight, at night, or near water.
- The motor and batteries can become hot during use. Do not handle either after use to avoid injury.
- Your vehicle is controlled by radio. Radio waves are subject to interference from outside sources. Radio interference can cause loss of control of your vehicle.
- Always allow a margin of safety in all directions.
- Keep all small parts and anything electric out of the reach of small children.

SUPPLIED EQUIPMENT, TOOLS AND BATTERIES

Your vehicle comes with all the equipment, tools and batteries you will need to operate it.

You will need to purchase additional batteries for both the Transmitter and Vehicle. The batteries included are Alkaline Batteries provided to get you started. Alkaline batteries will work well for your transmitter.

Radline RC recommends you purchase Four Rechargeable Nickel Metal Hydride (NiMH) AAA batteries for use in your vehicle. The milliamp hour (mAH) rating of the batteries determines how long your vehicle will run. A 2000 mAH rated battery will run twice as long as a 1000 mAH rated battery. We recommend you purchase a high mAH rated set of batteries. You will also need a quality NiMH charger for your batteries. Please follow battery and charger manufacturer's directions when using rechargeable batteries.

- | | |
|-------------------------------------|----------------------|
| 1.) Transmitter antenna | 7.) Screwdriver |
| 2.) Body pins | 8.) Owner's manual |
| 3.) Antenna cap & tube | 9.) label sheet |
| 4.) 10 teeth & 12 teeth pinion gear | 10.) 4 x AAA battery |
| 5.) Gear puller | 11.) 1 x 9V battery |
| 6.) Shock spacer | |

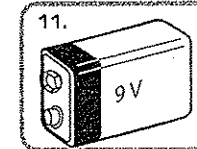
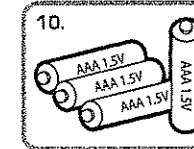
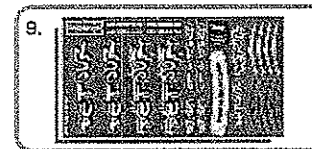
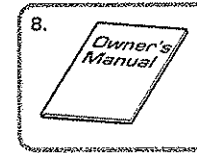
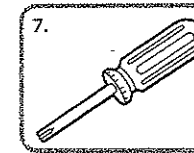
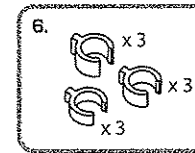
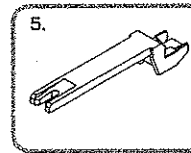
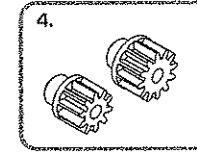
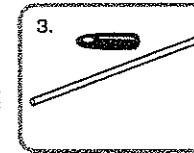
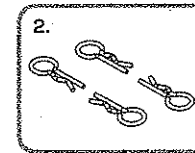
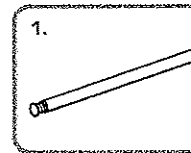

YOUR RTX-1 RADIO SYSTEM

Your vehicle is equipped with an RTX-1 Radio System. The RTX-1 Radio System is a 2-channel, 3-Band system that operates on either a 27 or 49 Mhz radio frequency. The frequency your transmitter operates on is clearly marked on its back (controller). The 27 MHz / 49 MHz frequency is divided into one of three bands: Red, Orange or Green. The vehicle included runs on the same frequency as the transmitter, and can run on all three bands: Red, Orange and Green.

Matching the transmitter and car frequency and band is simple and mandatory for proper operation. The three bands allow you to race up to three different cars on each of the two radio frequencies at the same time. If you have three vehicles running on 27 MHz, and three on 49 MHz, you can race six different cars at once.

The transmitter (controller) controls your vehicles steering, forward/reverse and speed.

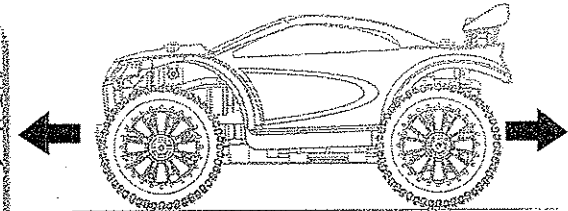
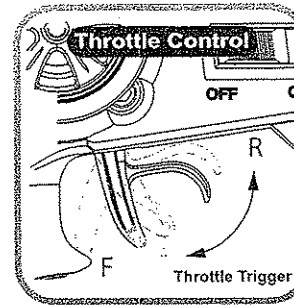
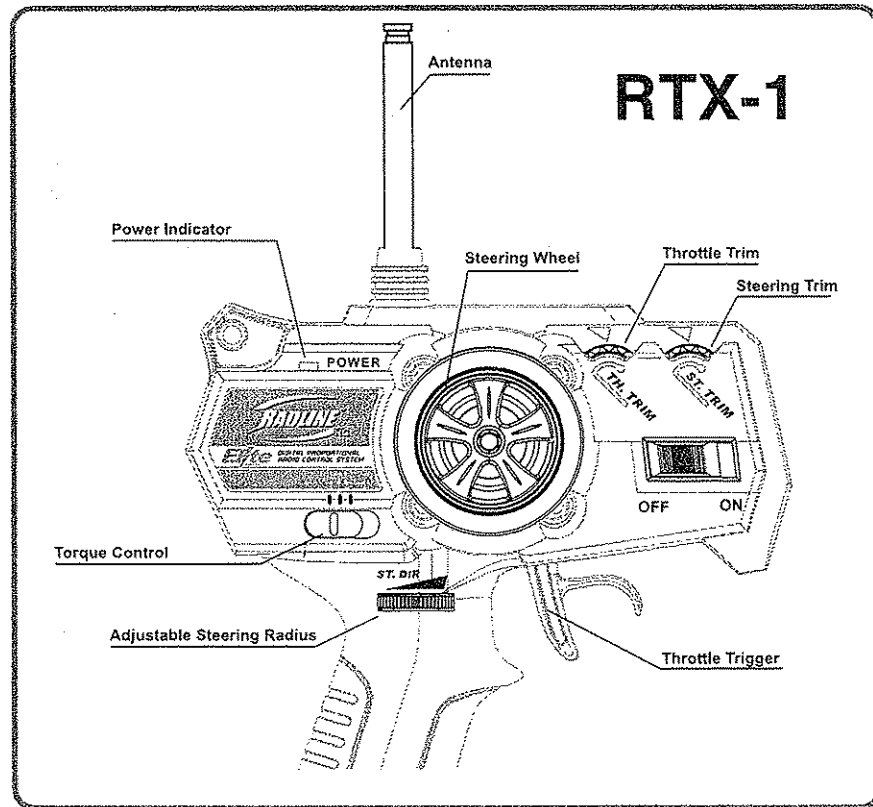

Throttle Control: The throttle control allows you to accelerate your vehicle in forward or reverse. You can push your throttle control to reverse and then neutral to apply the brake.

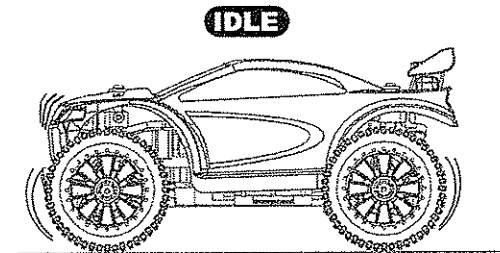
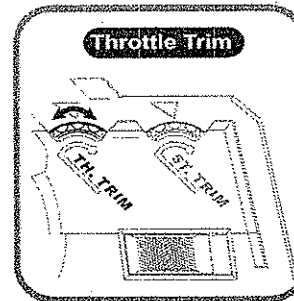

Throttle Trim: The throttle trim located on the face of your transmitter adjusts the IDLE when the it is at rest. You will need to adjust the throttle trim later when you have set up your vehicle.

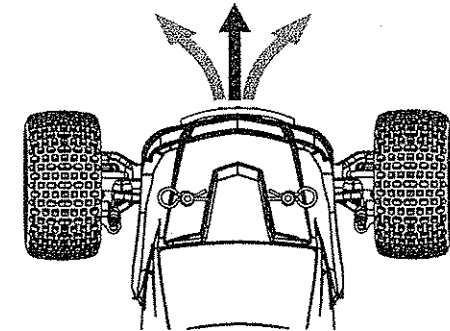
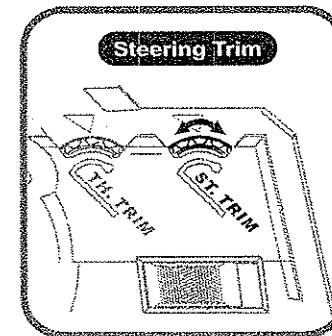

Steering Trim: The steering trim located on the face of your transmitter adjusts the neutral point of the steering servo. Adjust this control to make your vehicle drive straight with no steering input from the steering wheel. You will adjust the steering trim after you have set up your vehicle.

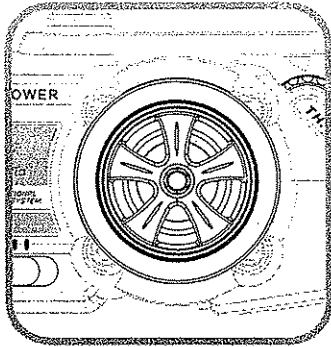

Steering Wheel

The steering wheel allows you to steer your vehicle left and right.

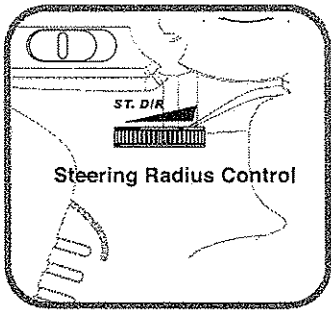

Steering Radius Control

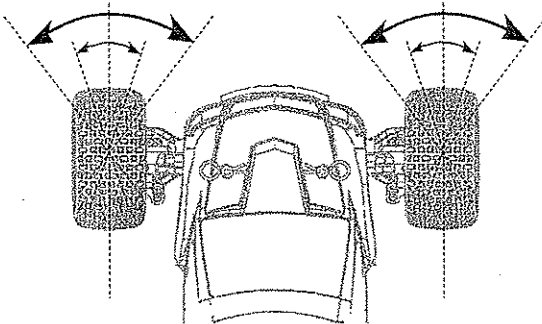

The steering radius control knob located on the face of your transmitter allows you to select the radius of your turns. Moving the knob to the left increases the turning radius and is designed for novice 'drivers'. Moving the knob to the right decreases the turning radius and is designed for experienced drivers.

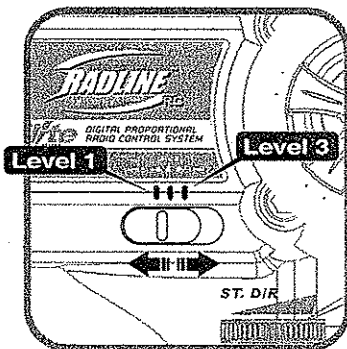

Acceleration Control

Located on the face of your transmitter, you can adjust the torque or speed of acceleration with this switch. Level 1 is the slowest acceleration selection, and Level 3 is the fastest acceleration selection.

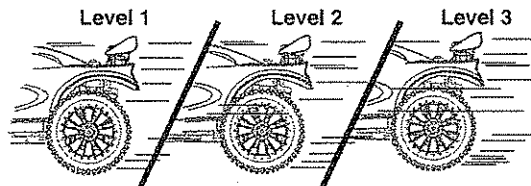

Band Selector Switch

The band selector switch is located at the back of your transmitter and allows you to easily select one of three bands: Red, Orange or Green. This band must match the band on the vehicle that you select when you set up your vehicle, and may be changed by you at any time to allow multiple vehicles to race at the same time.

Red Light

Green Light

Orange Light

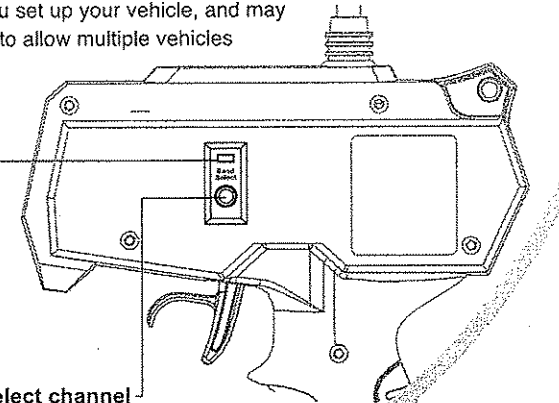

Press the Button for select channel

R RED LIGHT

G GREEN LIGHT

O ORANGE LIGHT

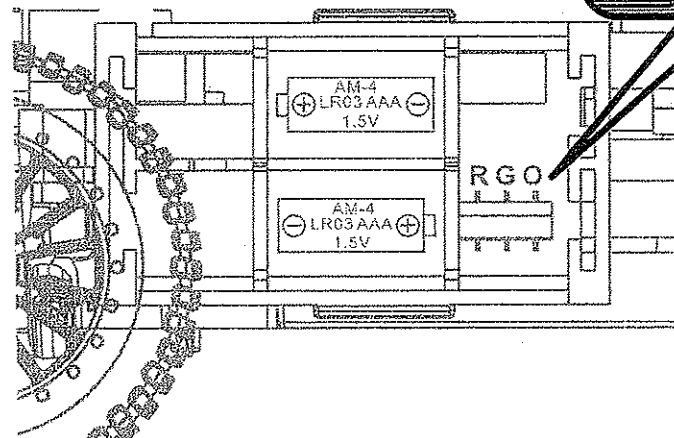
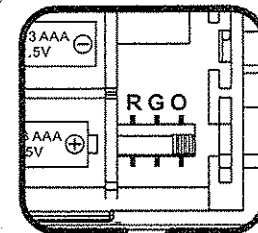

Installation of Antenna

Always turn on your transmitter before turning on your car, as your car could be effected by outside radio signals if your transmitter is not on and properly functioning.

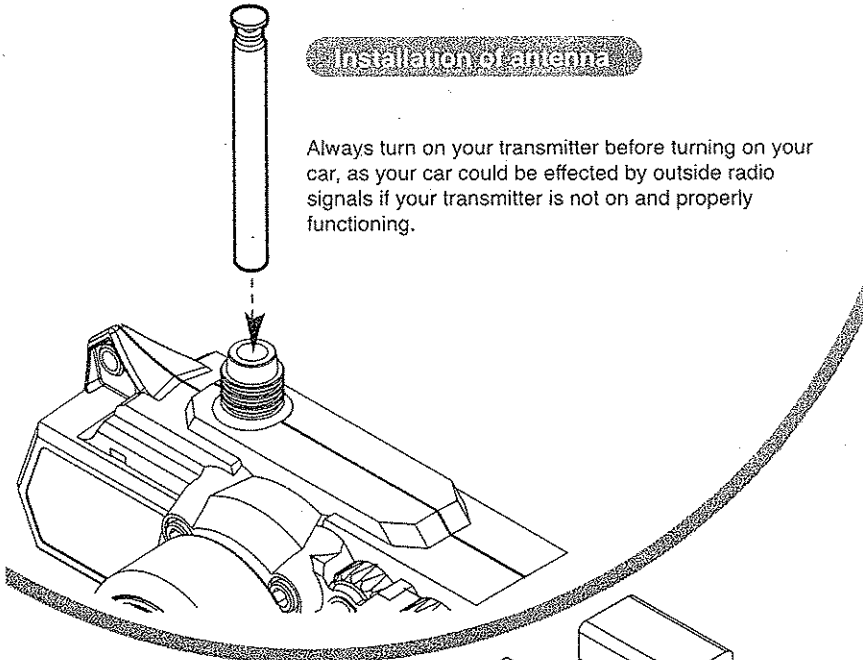

Installation of Battery

Your transmitter uses one 9-Volt battery. The battery compartment is located in the base of the transmitter. Press down and towards the back of the transmitter to remove the battery cover. Insert the 9-volt battery in the correct orientation according to the polarity marked inside (+ and -).

Battery Notes:
 Turn on the transmitter using the On/Off Switch. Confirm the Power Light is on. If the power light is not illuminated, check the polarity (+ and -) of the battery. If you are confident you have properly positioned the battery and the power light is not on, then try a new battery.

Once the battery light is on you may turn off the transmitter and replace the battery cover.

• When you notice the BAND LED is blinking or the control range of your vehicle decreases, replace the battery.

• Use only fresh batteries of the required size and type.

• Do not mix old and new batteries or different types of batteries (standard, alkaline or rechargeable) or rechargeable batteries of different types (NiCd or NiMH).

• If you are not planning to use your vehicle for several days, remove the batteries. Batteries can leak and damage your vehicle. Dispose of batteries properly. Do not burn or bury batteries.

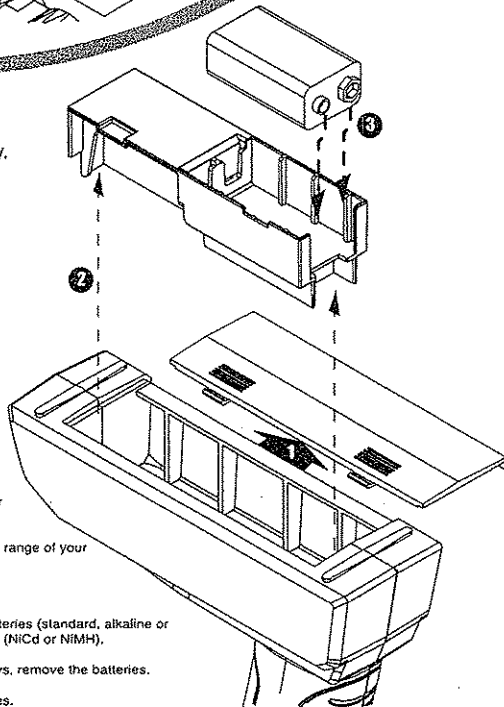

THE RL4 CHASSIS

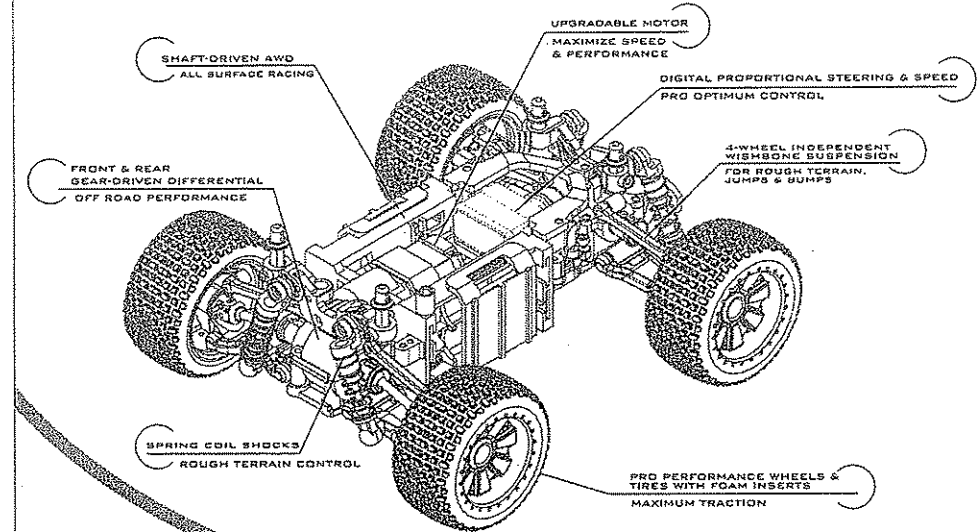

Bottom View

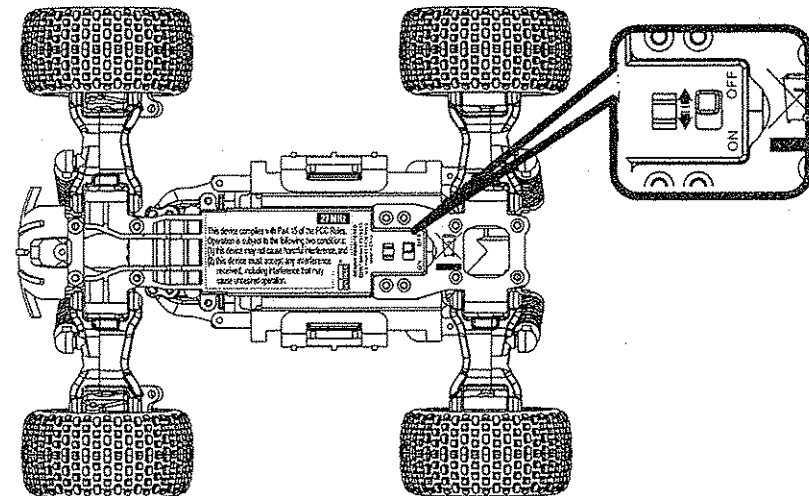

Top View

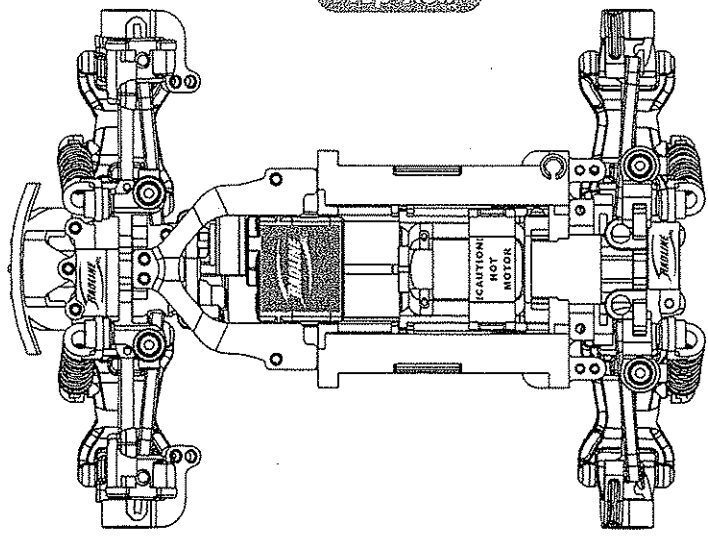

Side View

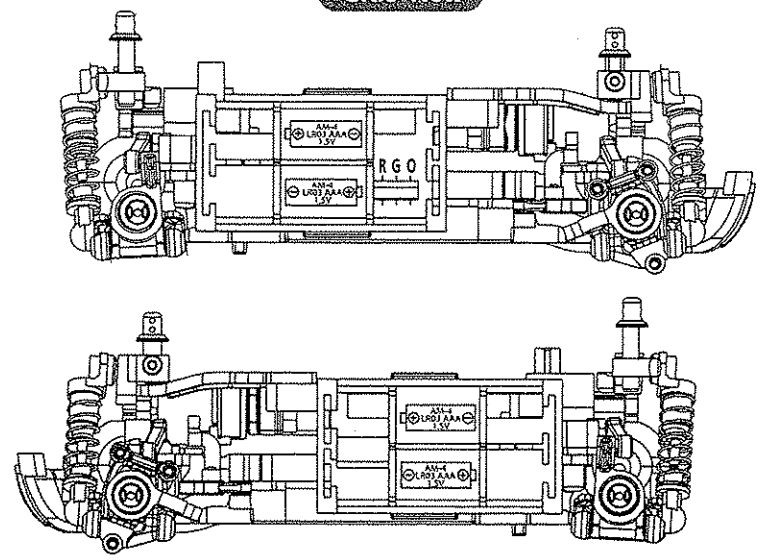

Setting up the antenna

You must install the antenna mast (tube) before you operate your vehicle.

Locate the antenna wire that is fixed to the receiver.

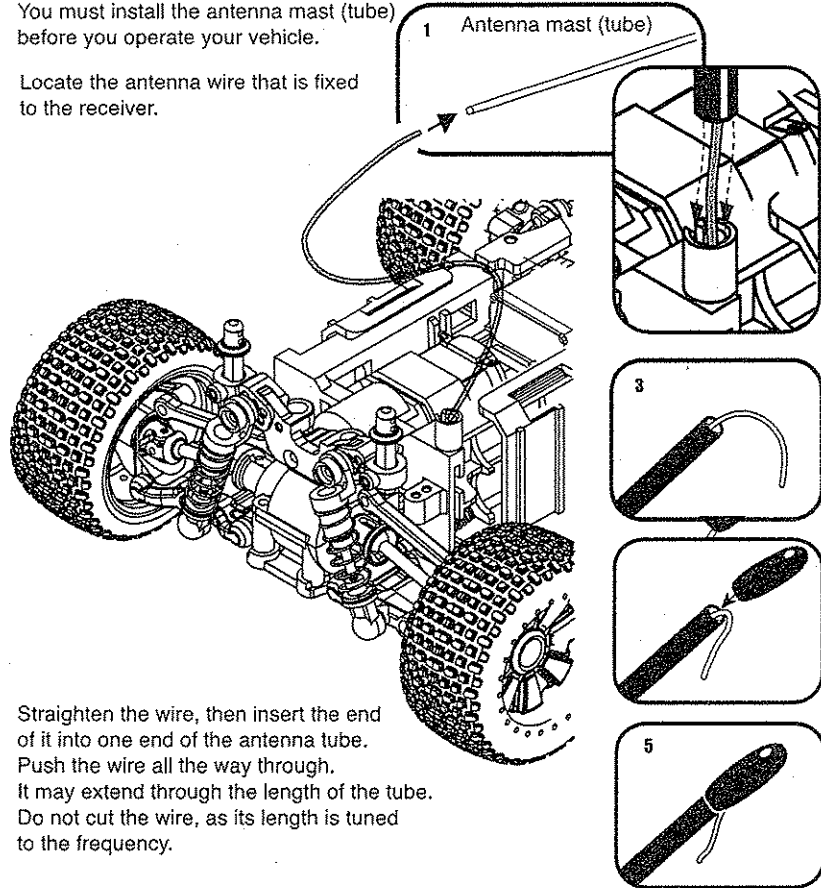

Straighten the wire, then insert the end of it into one end of the antenna tube. Push the wire all the way through. It may extend through the length of the tube. Do not cut the wire, as its length is tuned to the frequency.

Insert the base of the tube into the molded post on the chassis. Hold the antenna tube at the bottom of the tube. Do not push from the top. Feed the antenna wire into the slot provided on the post. Gently secure the tube into the post.

Fold any remaining wire over the tube and secure the wire and/or cap the tube with the antenna tip. The wire may not extend past the tube.

Always fully extend the antenna on the transmitter and face the antenna on the transmitter straight up for best performance.

SELECT ONE OF THE THREE BANDS (RED, ORANGE OR GREEN)

Your vehicle runs on either 27 Mhz or 49 Mhz as was preset at the factory. You cannot change the frequency. Your car also runs on one of three bands that you can change, and allows you to race three cars with the same frequency at once without one interfering with the others. You can race against any vehicle that is running on a different frequency from yours without concern for interference.

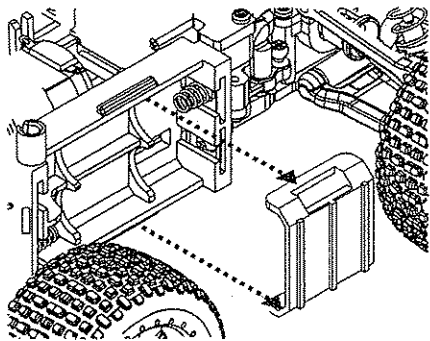

To change the band and prepare for battery installation, gently lift up and out on the top edge of the battery covers to remove from the chassis. If it is difficult to remove the battery cover, you may want to use a small flat head screwdriver (not included) to gently lift and push out the battery cover.

Locate the 3-Band switch that is located in the right hand side battery box in the lower right hand corner. This switch has three positions: Red, Green and Orange. Your transmitter default band is red. Your car is also preset

on the red band. If you are planning to be racing against other cars, you may want to select another band now or select an alternate band at a later time.

To change bands, use the small Philips head screw driver included and slide the switch to the right. The middle stop is the green band and the right stop is the orange band. The default band is red located on the left stop. You will match the transmitter band to the car band later when you tune your vehicle.

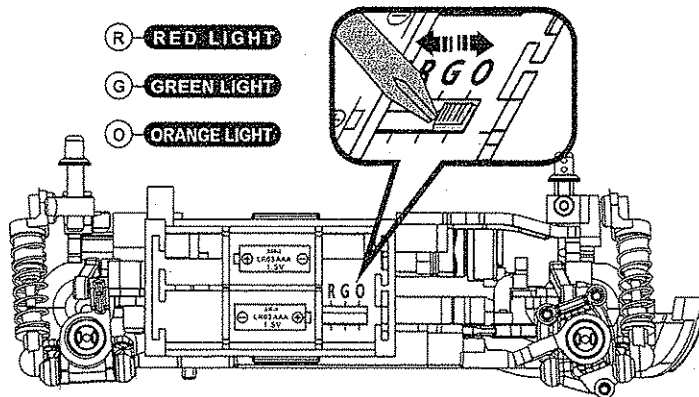

Install Batteries

The four AAA batteries provided are alkaline batteries and will have a very limited life. They are provided to get you up and running. You will need to replace the batteries very soon.

We suggest you replace with four AAA rechargeable Nickel Metal Hydride batteries (NiMH) available at your local hobby dealer. You must use a recharging unit designed for recharging NiMH batteries. Follow the manufacturers directions for use and charging.

Insert two AAA batteries into one of the two battery compartments being careful to insert in the correct orientation according the polarity marked inside (+ and -).

Replace the battery cover by placing one side over the raised holder and pushing in gently on the other side. The battery cover will snap into place.

Repeat steps above to insert batteries in the second battery compartment.

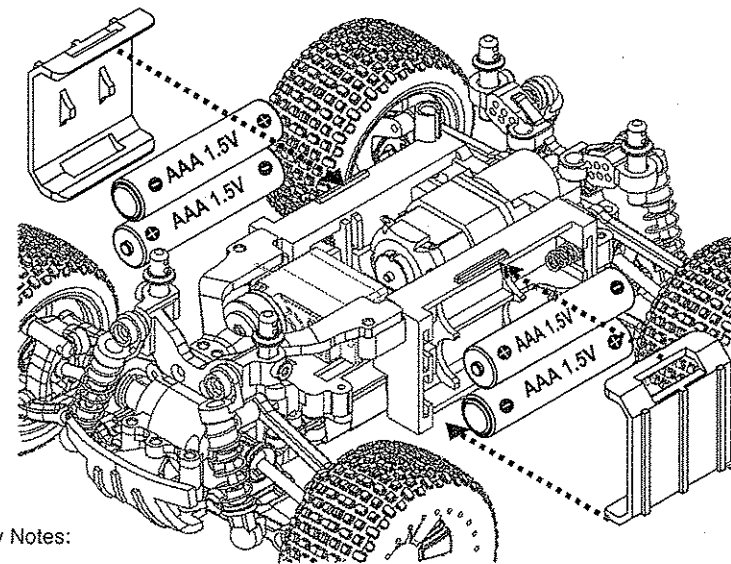

Battery Notes:

- When you notice the speed of your car is decreasing or the BAND LED is blinking it is time to replace the batteries.
- Use only fresh batteries of the required size and type.
- Do not mix old and new batteries or different types of batteries (standard, alkaline or rechargeable) or rechargeable batteries of different types (NiCd or NiMH) or different capacities.
- If you are not planning to use your vehicle for several days, remove the batteries. Batteries can leak and damage your vehicle.
- Dispose of batteries properly. Do not burn or bury batteries.

ATTACHING THE BODY TO THE CHASSIS

Guide the antenna through the antenna hole in the car body.

Set the car body over the four posts on the chassis.

Using the four body pins provided, slide one into the hole on each of the four posts.

Detour

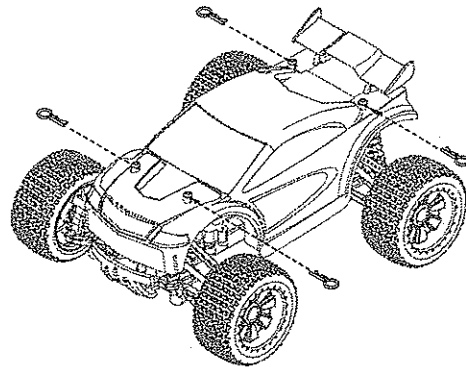
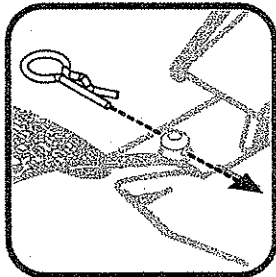
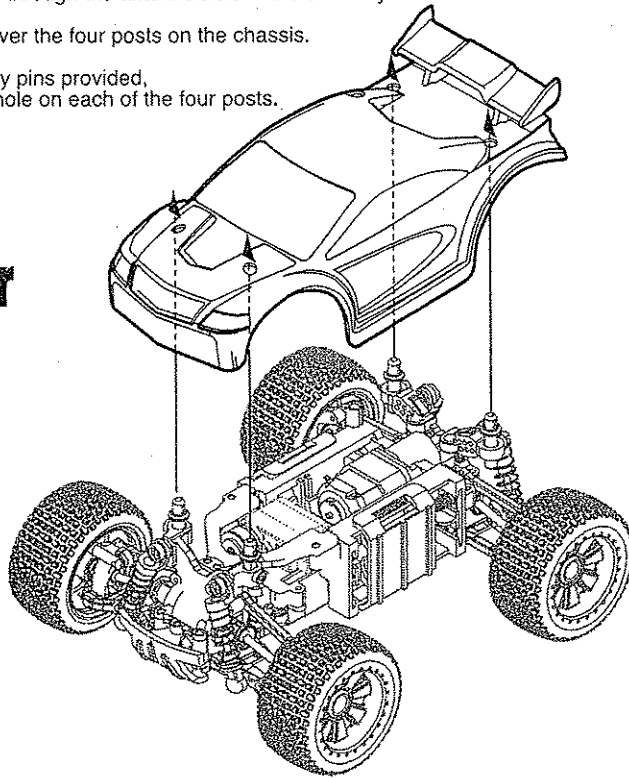

15

Warpath

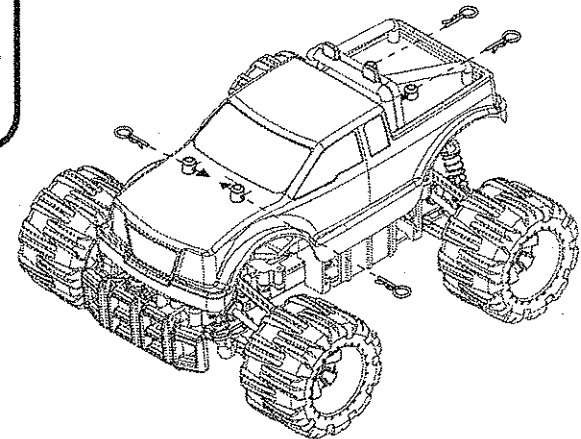
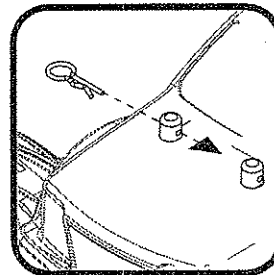
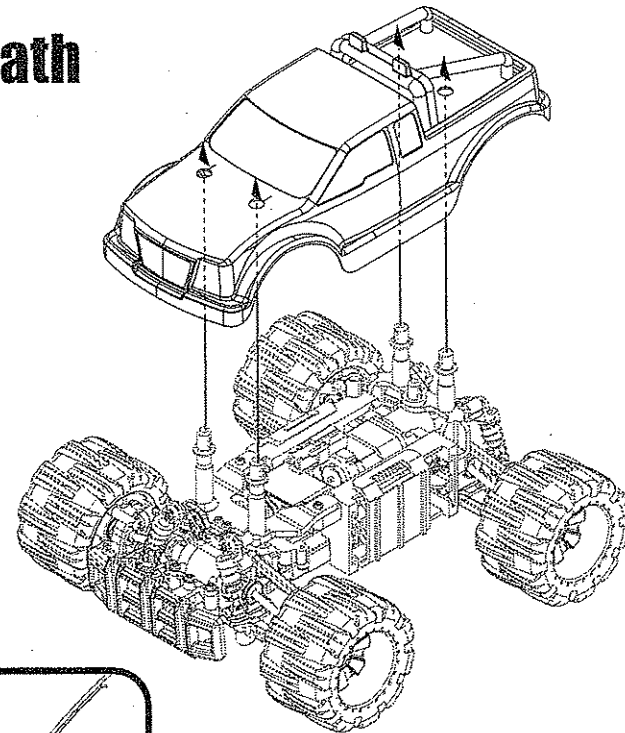

16

Fang

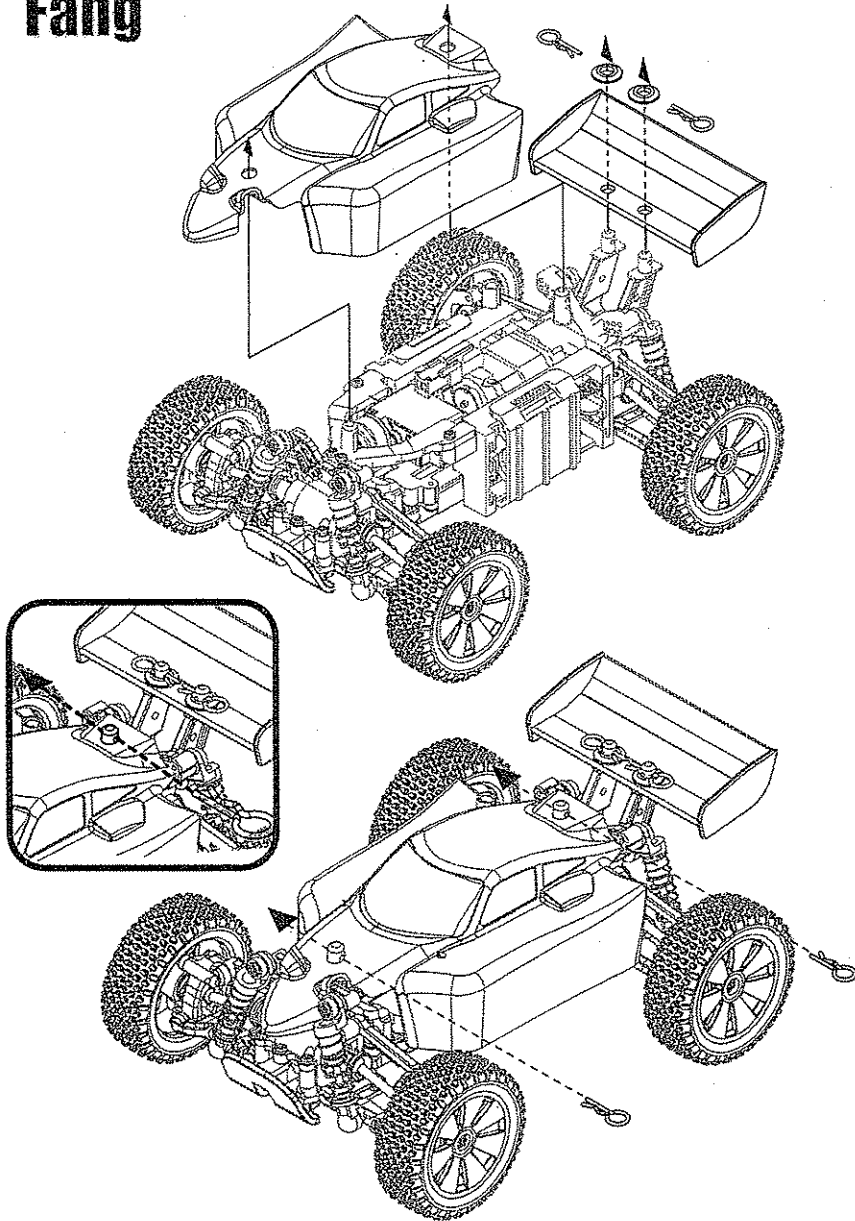

DECORATE YOUR VEHICLE BODY

The decals are printed on self-adhesive label stock. Gently remove the labels from the backing and place one edge in the proper position on the car body. Gently smooth the decal down with your finger. This process of smoothing from one side to the other will prevent air bubbles under the label.

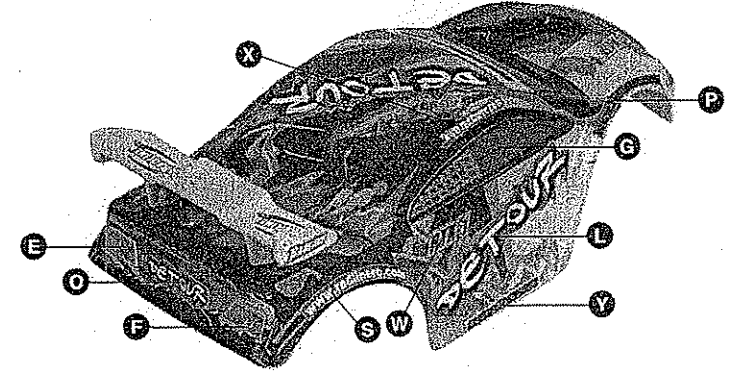
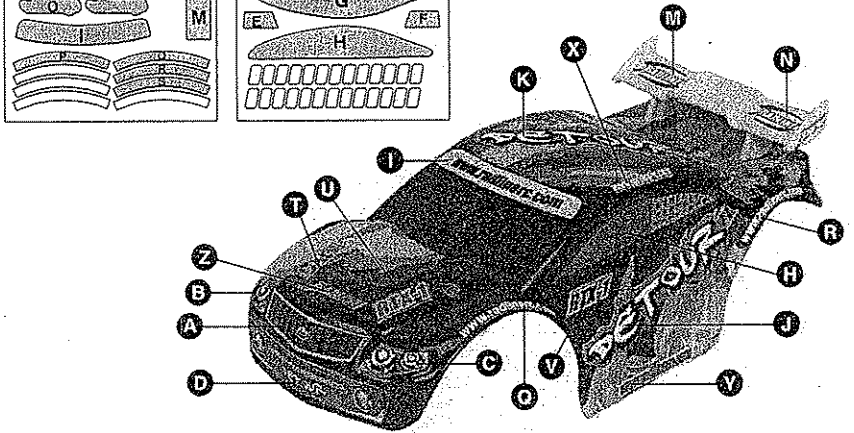
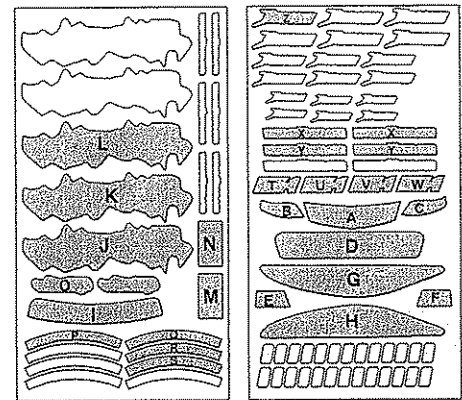

DECORATE YOUR VEHICLE BODY

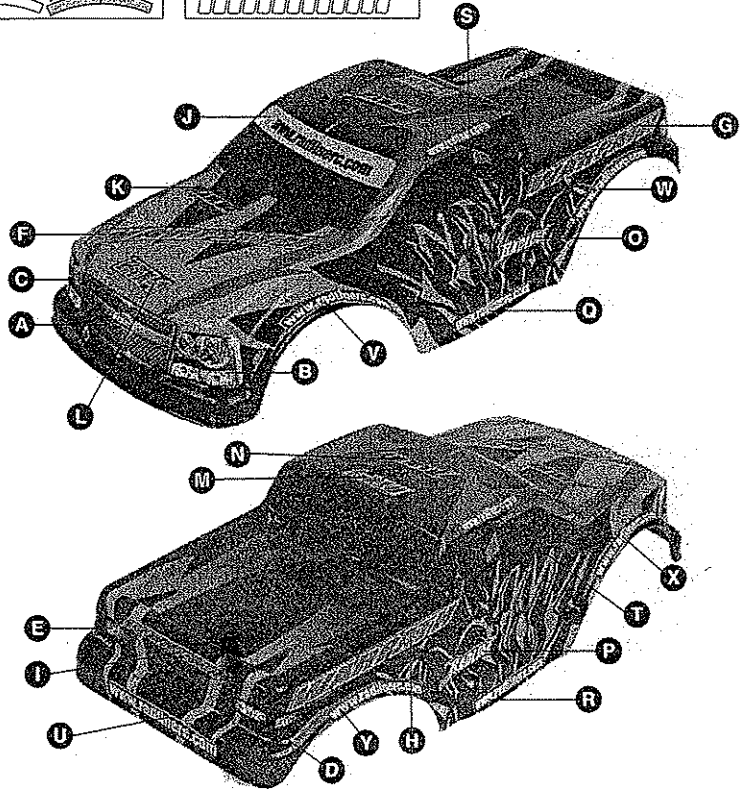
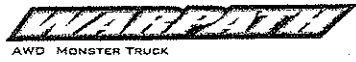
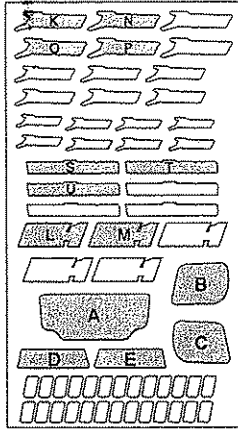
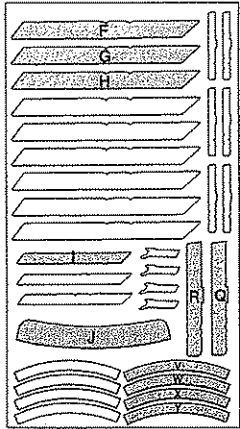

DECORATE YOUR VEHICLE BODY

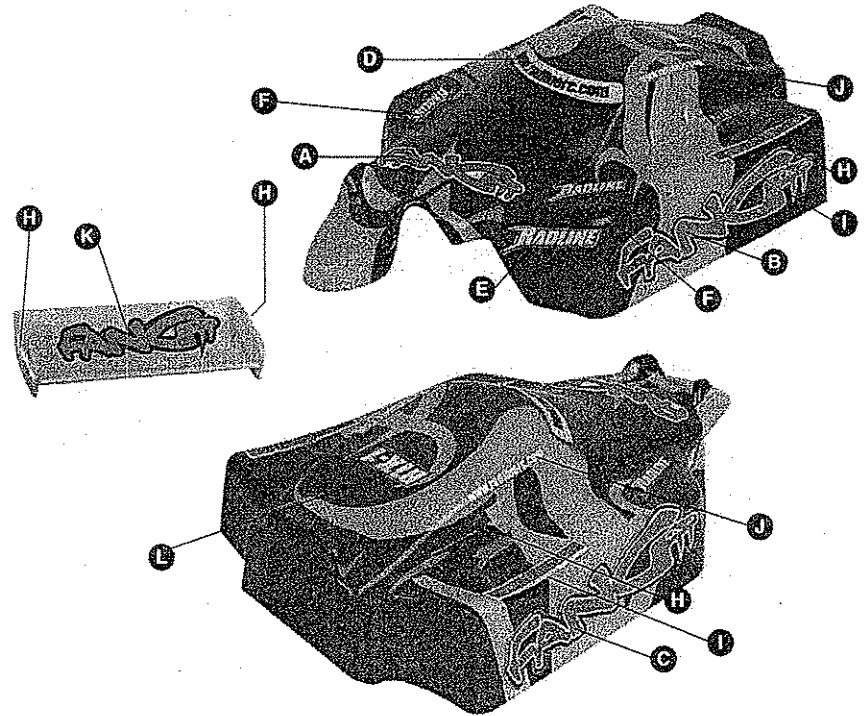
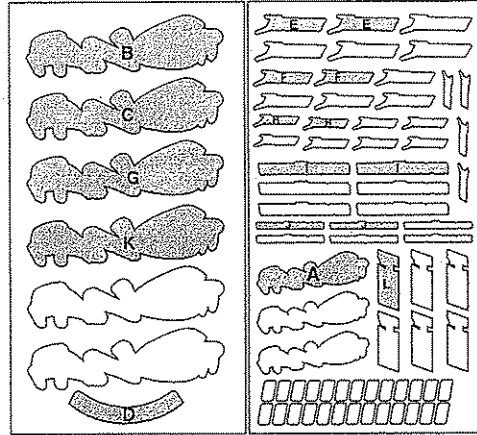

TIGHTEN THE WHEELS ON YOUR VEHICLE

The wheels on your vehicle can be removed and or replaced. They should be properly secured out of the box, however it is a good idea to confirm your wheels are properly attached to the chassis. Place the chassis on a flat surface on its four wheels. Now hold one wheel so it does not turn, and, using the Philips head screwdriver provided, gently turn the screw located in the center of the wheel clockwise to tighten. This should be done slowly and gently--DO NOT FORCE. Gently turn the screw clockwise until it stops turning. There is no need to over turn. Once the screw stops turning remove the screwdriver. Your wheel is now properly secured. Repeat this process on the other three wheels.

SETTING THE TRANSMITTER AND CAR BAND

Turn the Transmitter on. Fully extend the antennae. Recall the band you selected for your car (Red, Green or Orange). On the backside of your transmitter notice the LED color. The LED should be red. If you did not change your car band from the preset red, then your transmitter and car are both set on red and should perform properly. If you changed your car band to either Green or Orange you need to match that color on your transmitter. To switch the transmitter band to green, press the button once. To set to orange, press it twice. The color of the LED will change accordingly. You can press it one more time to return to the red band.

PRE-RUN ROUTINE

Hold your car in one hand and move the on/off switch located on the bottom of your car to the on position. Immediately confirm the LED color on the car matches the color you selected on your transmitter. If they do not match, press the button on the back of the transmitter until the LED color matches that on the car. You must confirm that your car and transmitter are on the same color for your car to perform properly.

Set your car on a block to lift the wheels off the surface or securely hold in one hand. Always turn the transmitter on prior to turning on you vehicle. Your vehicle could be controlled by outside transmissions if your transmitter is not on.

Adjust the throttle trim by turning the throttle trim knob clockwise until the wheels are moving. Once the wheels start to move turn the throttle trim knob counter clockwise slowly until the wheels stop and the car is making no sounds. Your throttle trim is now properly set. Repeat this adjustment each time you run your car.

Adjust the steering trim by looking down at the front wheels and turning your steering trim clockwise or counter clockwise to set the front wheels in the neutral position. You may want to make last minute adjustments to the steering trim when you start to run your vehicle.

Check your throttle by moving the throttle trigger forward and confirm the vehicle wheels move forward. Move the throttle trim backward to confirm the vehicle wheels move in reverse. Release the throttle trim to confirm the wheels stop moving in the neutral position.

Check your steering by turning the steering wheel clockwise and counter clockwise and confirming the front wheels respond properly.

Adjust the Acceleration Speed Control by selecting level 1 for slow start level 2 for faster start and level 3 for fastest start. Changing the starting speed will not effect the top end speed--it simply adjusts the speed at which your vehicle accelerates. Using level 1 adjustment will make it easier to control your car as a new driver or in confined racing areas.

Adjust the Turning Radius of your vehicle. Your turning radius can be adjusted for wide turning or tight turning radiuses. Move the Turning radius knob to the left to make wider turns and to the right to make tighter turns. This adjustment allows a new driver to handle the vehicle more easily in the wider turn setting and experienced drivers to make tighter turns when set in the tighter radius setting.

RANGE TEST YOUR VEHICLE

Because your vehicle is controlled by radio frequency, it is subject to interference from outside sources including electric wires, adjacent building and other radio transmitters in the area. This interference can affect the distance or range your transmitter will effectively control the vehicle.

You have completed all the preparation and pre-run routine required before running your vehicle. But one last project is required--you should range test your vehicle before each run session.

Turn on your transmitter first. This will insure your car is not controlled by stray signals from another transmitter in the area. Fully extend the transmitter antennae. Hold the vehicle in your hand making certain you are not holding the wheels. Turn on the vehicle. Confirm that your vehicle is responding to your transmitter only. If there are other transmitters in the area you want to assure you are on different frequencies and or bands.

Place the car on the ground and slowly drive it out to the farthest point you plan to operate the vehicle. As you do this you can make last minute adjustments to the steering trim if necessary.

If you find your vehicle stops or cannot be controlled as it moves farther away, you will have to limit the range you plan to run your vehicle. Once you have determined the range at which you can control your vehicle, you can establish the area in which you can safely run it.

RUNNING YOUR VEHICLE

You are now ready to run your vehicle more aggressively. Have fun, but remember that your vehicle travels quickly and turns quickly. Your driving skill must be developed to properly control the vehicle at high speed. Start out at slow speeds to assure you do not damage your vehicle.

During and after operation, the motor and batteries will be hot. Do not touch them until they have cooled down.

TUNING YOUR VEHICLE

Your vehicle came with a preinstalled pinion gear. This (10 tooth) gear is designed for all surface running. If you want more top end speed and can accept slower acceleration and you are planning to run on hard, smooth surfaces, you may want to install the included larger pinion gear (11 tooth). This larger pinion gear is not intended for rough terrain. Follow the diagram below to remove the motor from your vehicle and install the larger pinion gear.

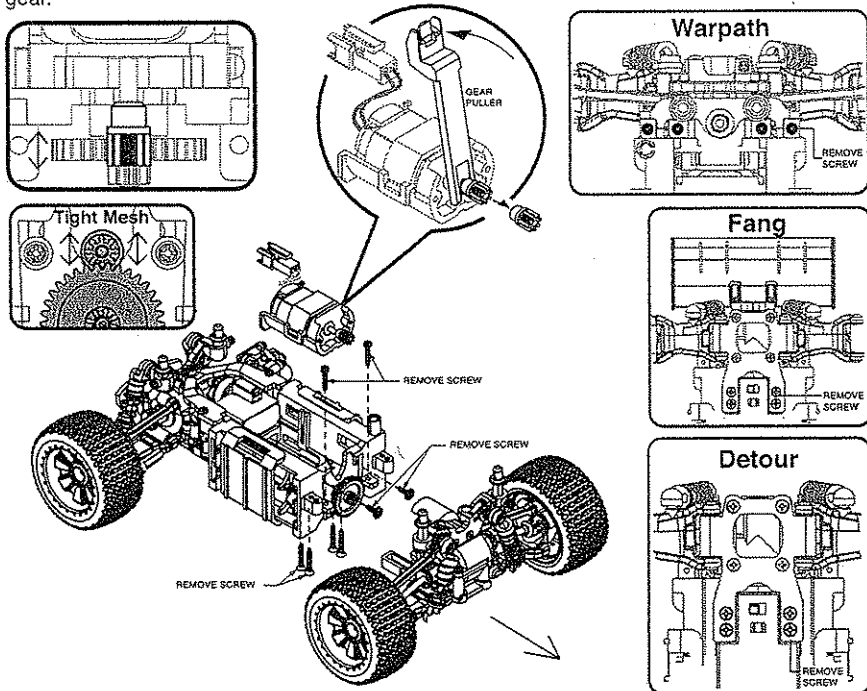

Radline RC offers a variety of after market optional performance parts that allow you to further tune your vehicle. You may want to purchase the Radline RC Performance parts for your vehicle.

Racing Motor-Pack: This pack includes three stock motors, each with different RPM and Torque ratings and a variety of pinion gears. This Three-Motor-Pack will give you a variety of speed and torque options to assure top performance in all racing conditions.

Modified Motor: There are two different types of after market motors that can be purchased for your vehicle. There are stock motors with a variety of ratings available, including the stock motors included in the Racing Motor Pack mentioned above. There are also Modified Motors that feature ball bearings and come in a variety of wire thicknesses and number of turns of wire on the armature. The fewer turns, the more powerful the motor. Our Radline RC Modified Motor will give you more power than any of the motors included in the Racing Pack.

Optional Pinion Gears: This performance pack includes a variety of pinion gears for top performance under any conditions. (Pinion Gear: 13T, 14T, 15T, 16T Spur Gear: 30T, 31T, 32T)

Precision Ball Bearing Set: This performance pack of ball bearings assures low friction performance. Lower friction means faster speeds. (anything else you can add)

Turnbuckle Set: The upgrade turnbuckle set allows you to align the front end of your vehicle. Toe in 1-2 degrees for increased stability.

Optional Shock Springs: This set provides 3 performance sets of front and rear springs. Use the different spring tensions to increase stability and performance on different surfaces.

Oil Filled Shock Pack: Add oil filled shocks to your vehicle to adjust the dampening. Proper set up of the oil filled shocks will add stability and increase handling.

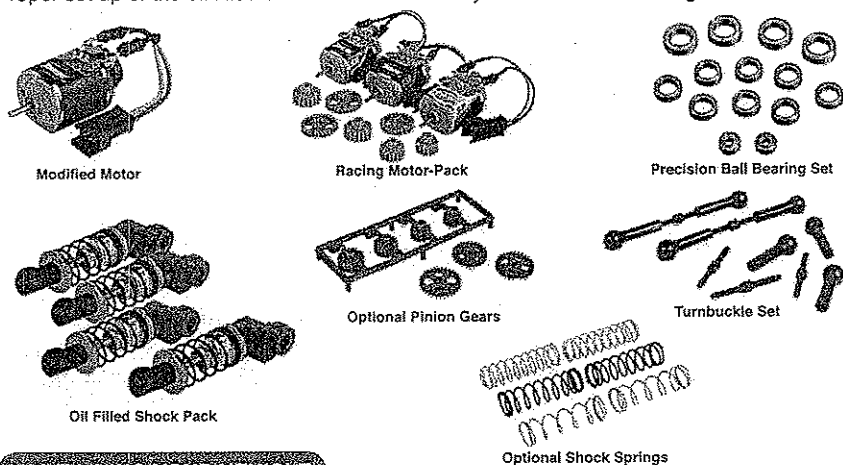

MAINTAINING YOUR VEHICLE

The following procedures should be performed frequently and will keep your vehicle running strong.

- Inspect the vehicle for any obvious damage.
- Check the gears for wear, debris or broken teeth.
- Check the wheels and tighten the wheel screws properly.
- Check for loose screws in the chassis.
- Check the wiring for frayed or damaged wires or connectors.
- Check the steering servo which will wear out over time and require replacement.
- Check all batteries
- Keep the chassis clean and free of sand, dust, dirt and moisture
- Remove and clean the motor after five sessions. Use electric motor cleaning solution available at your local hobby dealer to clean out dirt, sand and dust. Lubricate the bushings of the motor with a light weight electric motor oil
- When you put your vehicle away after running, dust off with a soft bristle brush or cloth.
- Remove batteries from vehicle and transmitter if you are going to store them for more than two days.

Repairing And Replacing Worn Or Broken Parts

All the replacement parts for your vehicle are available from your local hobby dealer or from Radline RC. Please remove the exploded view of your vehicle below to assist in the repair and/or identification of parts required.

Detour

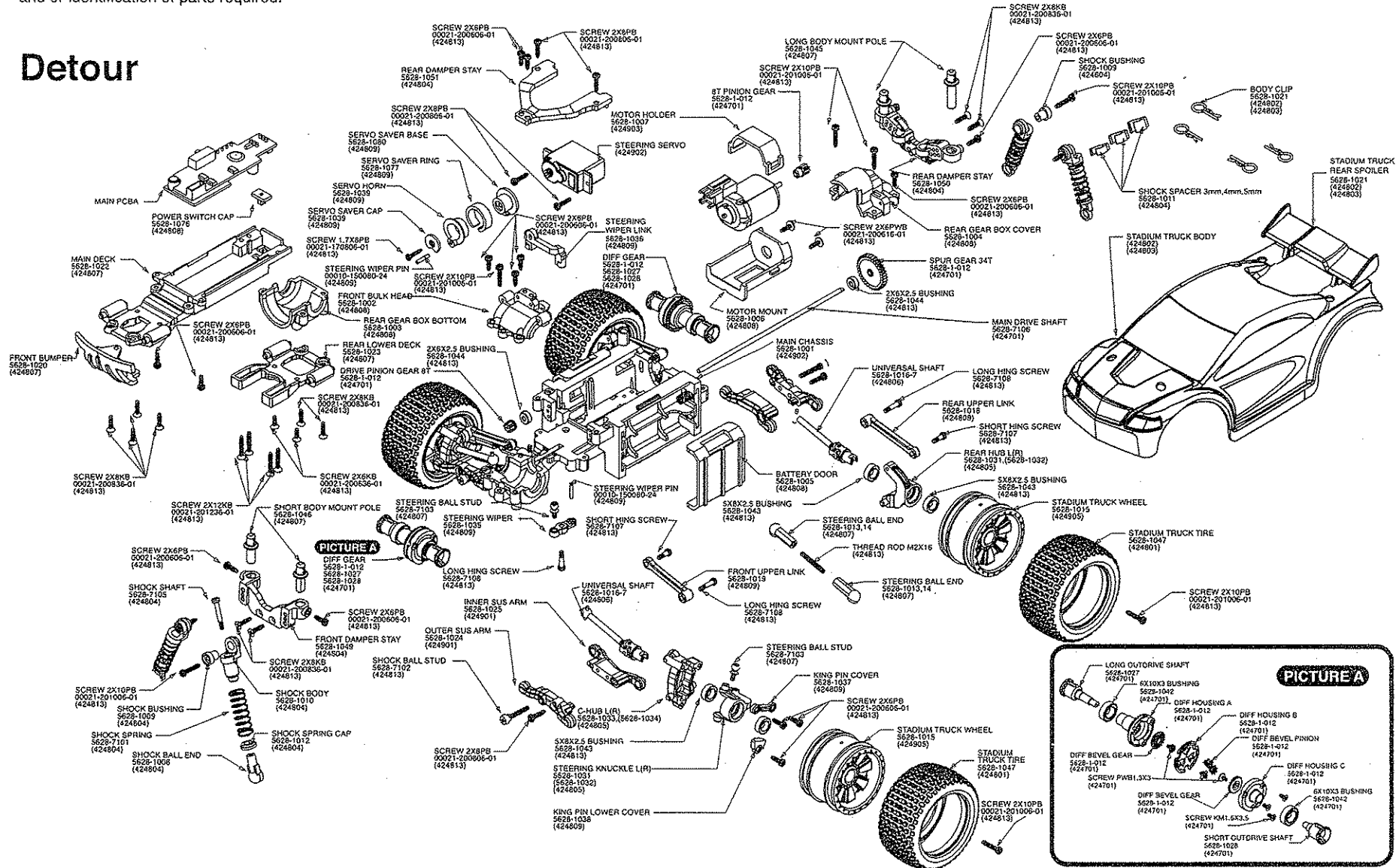

Warpath

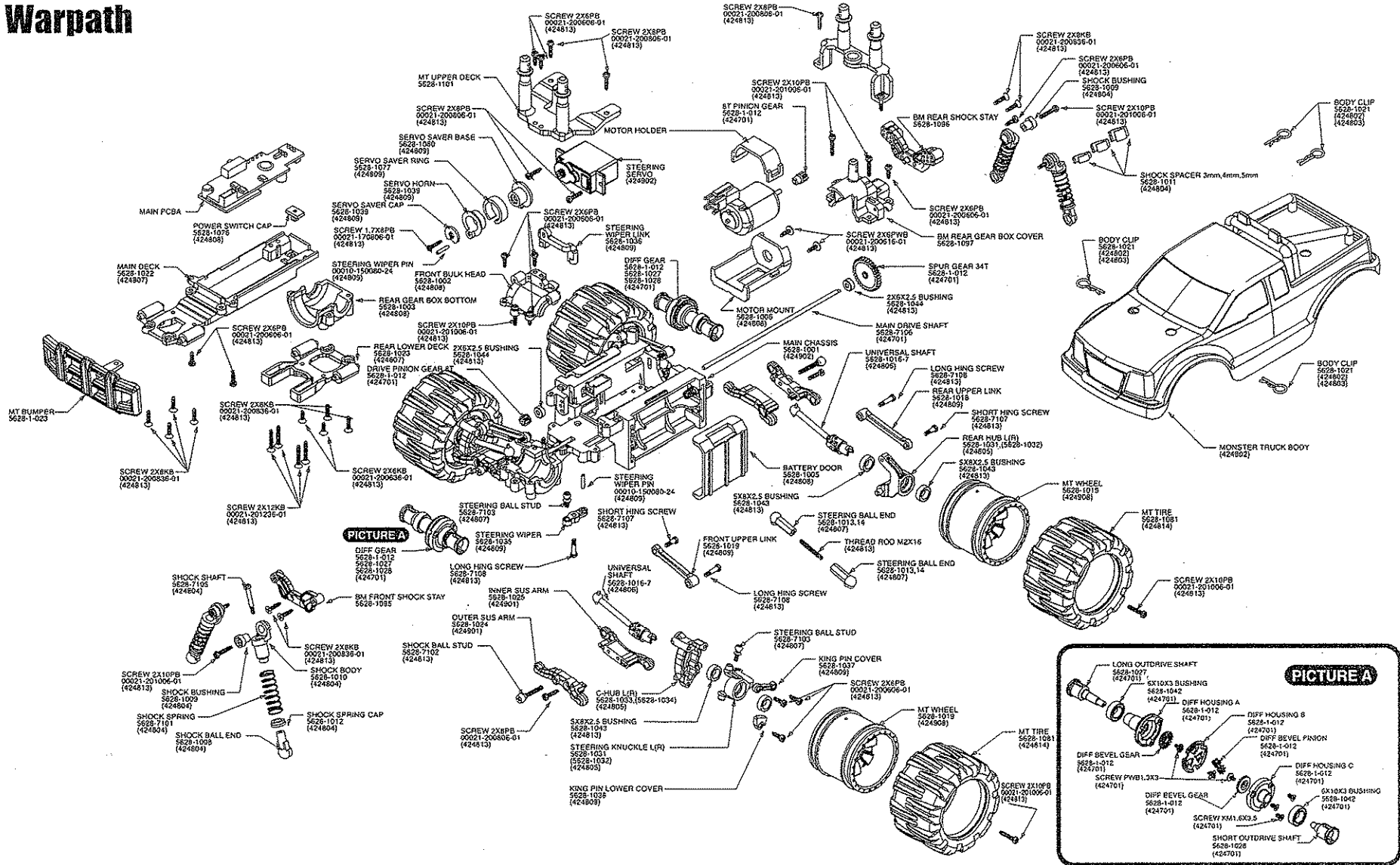

PICTURE A

PICTURE A

TROUBLESHOOTING

Radio System is not working properly

If power light does not come on or is not bright, replace battery

If the power light is on, but the vehicle does not respond properly, check that the battery is installed properly.

Check to see that your vehicle and transmitter are on the same frequency and are set to the same band color.

If range is short, fully extend the antenna. Check the battery. Try a different location---there may be interference from local sources.

Steering System works but the motor does not run

Check the motor wiring connection to assure it is tight and fully connected.

Replace the vehicle batteries.

Check all wiring.

Motor may be bad. Replace motor with a new motor or send motor to Radline RC for review.

Contact Radline RC for return authorization number.

You are always welcome to contact Radline RC for technical advise or repair options.

Limited Warranty

Unimax Toys Limited warrants to the original consumer purchaser this product against defects in material and workmanship as follows:

1. **LABOR:** For a period of thirty (30) days from the date of purchase. If this product is determined to be defective Unimax Toys Limited will repair or replace the product with a new or refurbished unit, at its option, at no charge. After the warranty period, the purchaser will pay the labor charges as outlined by RADLINERC at the time of the repair.

2. **PARTS:** In additions, Unimax will supply, at no charge, new or rebuilt replacement parts in exchange for defective parts for a period of thirty (30) days. After the warranty period the purchaser will pay for all parts.

In the event of a defect covered under this warranty, first call the toll-free number listed below. Many problems can be solved in a phone conversation. If necessary, you will be instructed to return the product, postage prepaid and insured to an address given you over the phone. Enclose your name, address, phone number, email address, dated sales receipt and a brief explanation of the defect. Repair or replacement and return shipment will be free of charge if the product is under Warranty.

This warranty does not cover cosmetic damage or damage due to acts of God or resulting from unauthorized modification, accident, misuse, or abuse. This warranty does not cover damage do to improper operation or maintenance. Proof of Purchase in the form of a bill of sale or a receipt of payment is evidence that the unit is within the Warranty period. If the product is returned without the dated sales receipt the product will be excluded from coverage under this warranty.

This Warranty is valid in the United States Only.

Unimax liability for defects in material or workmanship under this warranty shall be limited to repair or replacement, at our sole option, an in no event shall we be responsible for incidental, consequential, or contingent damages (except in those states that do not allow this exclusion or limitation). This warranty gives you specific legal rights and you may have other rights, which vary from state to state. Some states do not allow the exclusion of incidental or consequential damages. So the above exclusions or limitations may not apply to you.

For Warranty Support or for Assistance with repair or replacement of products out of Warranty \contact

Radline RC

Toll Free Number 1 866 4-Unimax (864629) (valid only in the United States)

Toll Number 1 949 858 5801

Hours: 9:00AM – 5:00PM Pacific Time; Monday – Friday (Holidays excepted).

Or visit our site: www.radlinerc.com

Email: CustomerSupport@radlinerc.com

RadlineRC

29883 Santa Margarita Parkway, #700

Rancho Santa Margarita, CA 92688

The FCC Wants You To Know

Modifying or tampering with your RadlineRC vehicle or transmitter's internal components can cause a malfunction and could void your FCC authorization to operate the equipment.

This equipment has been tested and found to comply with Part 15 of the FCC Rules.

Operation is subject to the following two conditions:

This device may not cause harmful interference

This device must accept any interference received, including interference that may cause undesired operation

Warning: Changes or modifications to this unit not expressly approved by the party responsible for compliance could void the user's authority to operate the equipment.

About FCC compliance

This device complies with Part 15 of the FCC Rules. Operation is subject to the following two conditions:

1) This device may not cause harmful interference, and

2) this device must accept any interference received, including interference that may cause undesired operation.

This equipment has been tested and found to comply with the limits for a Class B digital device, pursuant to Part 15 of the FCC Rules. These limits are designed to provide reasonable protection against harmful interference in a residential installation. This equipment generates, uses and can radiate radio frequency energy and, if not installed and used in accordance with the instructions, may cause harmful interference to radio communications.

However, there is no guarantee that interference will not occur in a particular installation.

If this equipment does cause harmful interference to radio or television reception, which can be determined by turning the equipment off and on, the user is encouraged to try to correct the interference by one or more of the following measures:

- Reorient or relocate the receiving antenna.
- Increase the separation between the equipment and receiver.
- Connect the equipment into an outlet on a circuit different from that to which the receiver is connected.

Consult the dealer or an experienced radio/TV technician for help.