

# **PX- Series Portable Radio Service Manual**

UNIMO Technology Co., Ltd.

- \* This Service Manual is subject to be changed without notice for performance improvement of PX-Series Radio.
- \* Version #1 (February 18, 2008)

==== Table of Contents ====

1. Features of PX-Series Radio
2. Basic Operations of PX-Series Radio
3. Appearance & Components of PX-Series Radio
4. How to charge the Battery
5. Operating Instructions of PX-Series Radio

## 1. Features of PX-Series Radio

PX-Series is designed to have 16 channels selectable switch, which allows users to select their desired channels with ease and PK-Series can be used at the industrial fields and public places for the safety & convenience of users. Also, for powerful sound and for better performance of conversation distance & sound quality, PX-Series has the built-in speaker in the large diameter of Ø40.

PX-Series has the following various functions.

- PLL Synthesizer Type
- 16 channels are selectable.
- Call Guard Squelch of standardized 53 CTCSS / 104 DCS Tones.
- Scramble function of Frequency Inverter Type
- Comander function
- Dual Tone Modulation Frequency (DTMF)
- Selectable Channel Spacing (12.5kHz / 25KHz)
- Normal Scanning and Priority Scanning
- Time-Out Timer (TOT)
- 2-Tone Paging
- BCL (Busy Channel Lock) / BCLO (Busy Channel Lock Out)
- High/Low Power Switching
- 10 Step Squelch Control Using RSSI (0~9)
- Remote Radio Stun/Revive (Use 5 Tone)
- Monitor
- VOX
- Easy Cloning
- USB PC Programming
- PC Tuning
- Advanced Speaker Protection Technology
- Powerful & Clear Sound by Ø45 Speaker (1Watt)

## 1.1 Part Number Breakdown of PX-Series

To identify PX-Series, please refer to the following Part Number Breakdown.

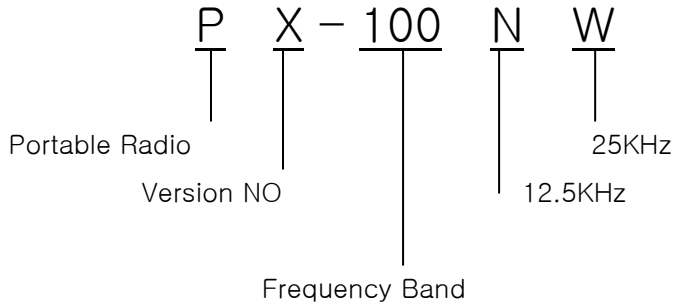

**Frequency Range / Power Output / Channel Spacing per Model**

Model NO.	Frequency Range	RF Power	Channel Spacing
PX-100NW	136~174MHz	5/2 Watt	12.5/25KHz
PX-400NW(A)	400~440MHz	4/2 Watt	12.5/25KHz
PX-400NW(B)	430~470MHz		
PX-400NW(C)	470~512MHz		

## 2. Basic Operations of PX-Series Radio

### 2.1 ON/OFF Volume Switch

Turn the knob of Volume Switch clockwise to turn the Radio on and if turning the Switch to the opposite direction, the Radio is turned off. The audio volume level can be adjusted by turning the Volume Switch and when adjusting the volume, please refer to the index mark indicated nearby the Volume knob.

### 2.2 Channel Switch

16 channels (CH 1 to CH 16) can be selected.

## 2.3 Status Indication LED

User can check the current status of PX-Series Radio by the color of LED and the status indication will be as follows.

- ① When the transmission status is normal, the red LED will be on.
- ② When the reception status is normal, the green LED will be on.
- ③ When the data of CTCSS or DCS code is not being received due to mismatch, the green LED blinks.
- ④ In case of Low battery, the red LED blinks and an alert sound is heard.

## 2.4 Speaker Mic. Jack

When using external speaker microphone and when making PC programming/Cloning/Tuning, the Jack is used and is designed to be compatible with Motorola external speaker microphone for more efficient use of PX-Series Radio.

## 2.5 Speaker

For dynamic sound quality and better sound, PX-Series is designed with Ø45 speaker built-in.

## 2.6 Emergency Key

If you press the Emergency Key in an emergency situation, an emergency siren sound will be heard through the speaker in the Radio and the Radio will transmit an emergency signal to the party through the emergency channel.

## 2.7 PTT Button

If pressing the PTT button, the status indication LED lights in red color and the Radio is converted to transmission mode. If releasing the PTT button, the Radio is converted to reception mode or standby mode. It is recommended to talk about 5~7cm away from the microphone for using in better sound quality and for better voice communication.

Also, by using PTT button and other button, it is possible to set up the RF Power.

- ① PTT button + Menu button : The Radio is converted to High Power(5W) and the status indication LED lights in red color.
- ② PTT button + Monitor button : The Radio is converted to Low Power(2W) and the status indication LED lights in orange color.

## 2.8 Menu Button (Scan Button)

If pressing Menu button for about 2 seconds, the Scan operation is proceeded and by pressing the Menu button again, the Scan operation is released.

## 2.9 Monitor Button

If pressing the Monitor button, the receiving status of the current channel can be checked.

Normal Mode : During pressing the Monitor button for about 2 seconds, it is possible to check the receiving status.

Continuous Mode : During pressing the Monitor button for more than 2 seconds, a beep tone is heard along with a noise and the monitor function is continuously maintained. If pressing the Monitor button again, the monitor function will be released.

## 3. Appearance & Components of PX-Series Radio

### 3.1 Appearance of PX-Series Radio



Figure 3-1) Appearance of PX-Series Radio



Figure 3-2) Top Appearance of PX-Series Radio

### 3.2 Basic Operation Method

Please read this user guide carefully before using this PX-Series Radio.

This user guide contains the detailed explanation about the installation & removal method of antenna and battery.

#### 1) Installation and Removal of Antenna

The Figure 3-10 shows the installation and removal method of antenna. Turn the antenna clockwise for installation of antenna and in order to remove the antenna from Radio, turn the antenna counterclockwise.

- ▶ **Caution:** When installation of the antenna, giving a strong pressure to the Radio or pulling the antenna from Radio with a strong power can make damage on the antenna connector, which may cause the Radio to have critical problem.

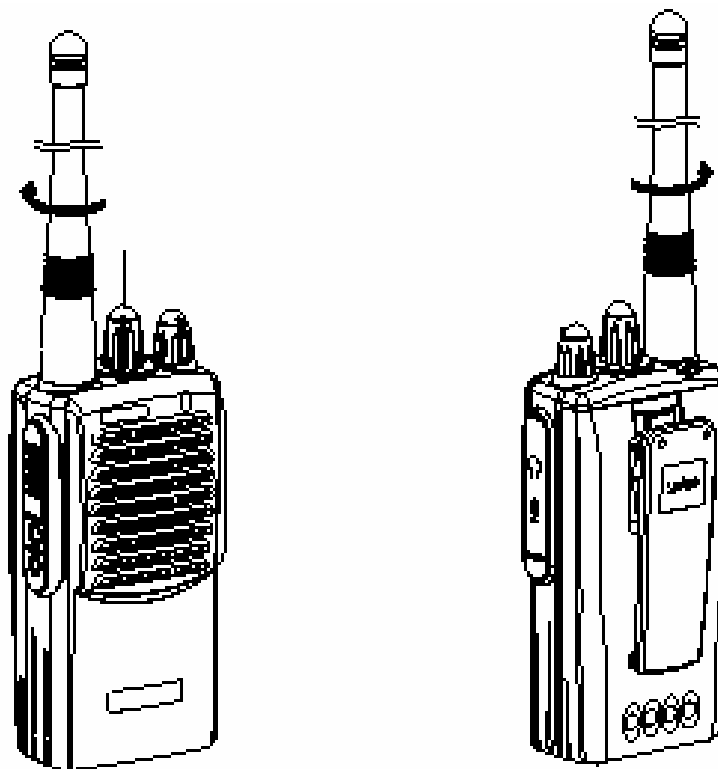

Figure 3-3) Installation & Removal method of Antenna

## 2) Installation and Removal of Battery

The Figure 3-1 shows how to remove battery. The material of Radio body on which the battery is installed is aluminium. If pushing the battery softly after alignment (③) of battery on the Radio body in aluminium material, the battery is installed with a similar sound to camera shutter.

In order to remove the battery from the Radio, move downwards (①) the locker on the top side of battery and pull (②) the battery pack at the same time.



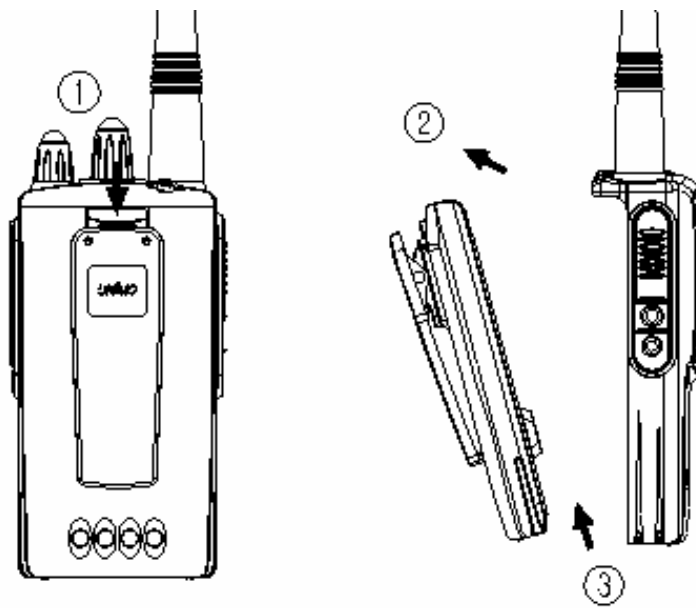

Figure 3-4) Installation & Removal method of Battery

### 3) How to Disassemble Radio

Unscrew 2 screws at the back side of Radio as shown on Figure 3-3 and by using a jig, pull the jig to the (O) direction and give the jig a lift to the (X) direction. Then, the case is disassembled from the Radio.

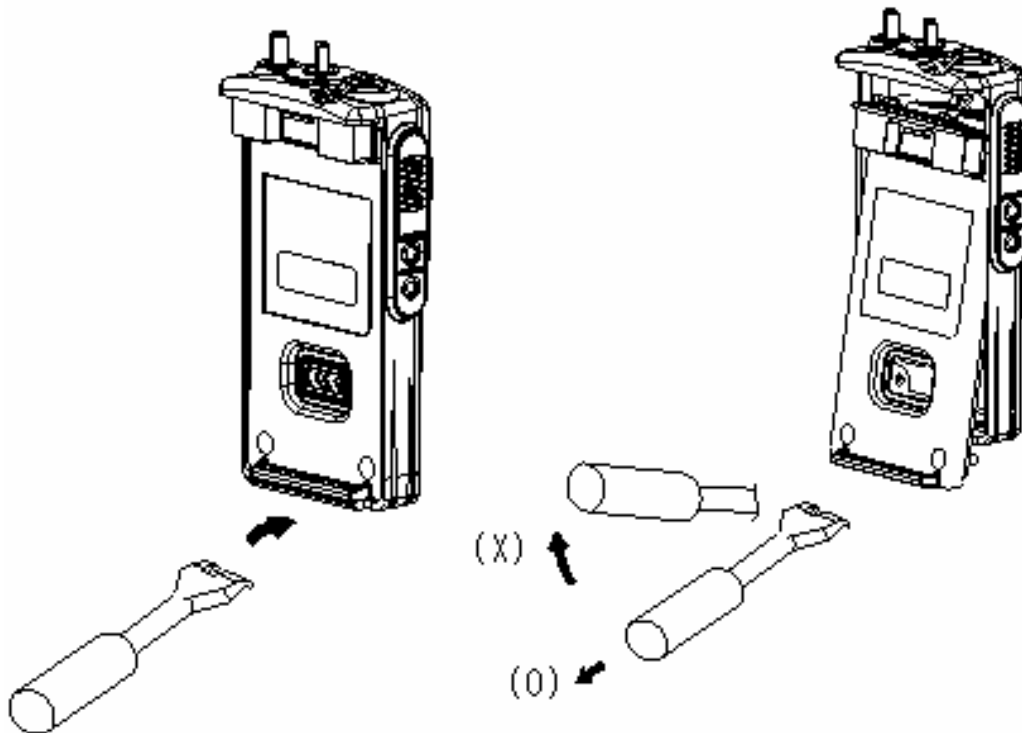

Figure 3-5) Disassembly Method of PX-Series Radio

## 4) Components of PX-Series Radio



PX-Series Radio



CHX-150FB



PBX-2150LB



User Guide



Hand-Strap



Antenna

## 4. How to charge the Battery

### 4.1 How to charge the Battery

PX-Series Radio is designed to use 2 kinds of batteries, which are PBX-2150LA (1500mAH Li-ion) of standard.

The PX-Series Radio receives power from high-performance Li-ion battery. The battery is safe, of high-performance and highly reliable. Using the enclosed standard charger makes it possible to get sufficient efficiency and lifetime of the battery.

- ▶ **Caution: Charging of the UNIMO battery on the other manufacturer's charger can cause unexpected damage of the battery and the Radio.**

## 4.2 When to charge Battery

Low battery voltage will shorten the talk range and will make the performance of Radio worse. Please make charge in case of followings.

- 1) When the battery has low performance after being used for 10~12hours
- 2) When the red LED on the front of Radio blinks (every 0.5 second) during transmitting or receiving signal
- 3) When a “beep“ sound (alert sound indicating low battery) is generated while the Radio is in use

### 4.2.1 How to check the remaining capacity of Battery

If pressing the Menu + Monitor buttons at normal mode, user can check the remaining capacity of battery.

Battery Capacity Status	LED Indication Status	Remarks
At Full Capacity	Green	
At 1/2 Capacity	Yellow	
At 1/5 Capacity	Red	

## 4.3 How to Charge

- 1) Plug the charger (CHX-150FB) into the electricity power outlet for AC220V.
- 2) When charging the Radio with the battery installed, insert the Radio into the charger slot after power off.
- 3) The charger (CHX-150FB) has one slot.
- 4) Although the green LED is on after full charge, please continue the charging for 30 more minutes for the complete full charge.

Status	LED Indication	Status	LED Indication
During charging	Red LED is ON.	When Error monitoring	Red LED blinks.
After complete charging	Green LED is ON.	During maintaining charge	Green LED is ON.

#### 4.4 Charger (CHX-150FB)

The CHX-150FB charger is designed to charge only the Li-ion battery enclosed in this Radio. It is possible to use the AC input voltage of AC85~250V.



Figure 3-3) Charger (CHX-150FB)

#### Specifications of CHX-150FB Charger

- Input Voltage : AC85 ~ 250V
- Available Battery : PBX-2150LA or PBX-2180LA
- Fast Charging Time : In 3 and half hours
- Operating Temperature : 0°C~+50°C
- Dimensions : 105(W)x105(D)x37(H)m/m
- Charging Current : 850mA(Fast Charging)

## 5. Operating Instructions of PX-Series Radio

### 5.1 Power On/Off

Turn Power switch clockwise and as soon as power is supplied, a “beep” sound is heard or the “Star Spangled Banner” is played and the Radio enters into the previous latest state.

☞ **Caution** : If turning power on by pressing a button on Radio, the Radio may enter into a special mode and in this case, the transmission and reception of Radio may not be possible. Don't use the Radio for the other purpose apart from the above.

### 5.2 Transmission Method

If pressing the PTT button on the left side of Radio for transmission, the DTMF is transmitted according to the setting as soon as the PTT button is pressed or a “beep” sound is heard at Dual PTT Mode. During this time, voice communication will not be made and after that, the red LED (High Power) or yellow LED (Low Power) for transmission and reception is turned on and voice is transmitted. For voice communication in the best sound quality, it is recommended to talk 5~10cm away from the Radio.

☞ **Note**: If transmitting consecutively for more than a certain time when setting of BCLO function and TOT function, the transmission can be forcibly interrupted for other users.

### 5.3 Reception Method

User can adjust the volume by using volume switch and during normal reception, the green LED is turned on. If frequency is same but Radio is not in a normal reception state, the green LED blinks. In order to check if the current channel is in use, press the Monitor button (M) on the left side of Radio. If pressing the Monitor button (M) for about 2 seconds, the monitor function is activated with a “beep” sound. To release from the monitor function, press the monitor button shortly.

### 5.4 Changing Channels

Channel Rotary Switch is used for changing channels. On the side of Channel Switch, channel numbers is stipulated and whenever changing channels, the Radio generates the different channel sounds every each channel. If the channel switch is located at a channel with no frequency on it, an alert sound is heard continuously and in this case, no transmission and reception is made.

## 5.5 Adjusting Transmission Power

The transmission power can be changed to High-Power or Low-Power. If pressing the MENU (SCAN) key during pressing the PTT Key, the red LED (High-Power) is turned on and if pressing the MON key, the yellow LED (Low-Power) is turned on. By changing the power to Low power under a good communication condition, the user can extend the use time of battery.

## 5.6 Operation of Scan Function

By pressing the **"Menu (Scan)"** button for more than 2 seconds in Standby mode, the Scan function is executed with a "beep" sound. To deactivate the Scan function, press the **"Menu (Scan)"** button once shortly or turn off and on the power.

### 1) Normal Scan

When the scan list is S1, S2, S3 at the normal scan mode, the Radio proceeds the channel scan in the sequence of S1, S2, S3, S1, S2, S3.... The user can delete (by pressing the EMR key) the current receiving channel temporarily from the scan list and at that time, user can move to the next channel. If getting out of Scan Mode or if turning on power again, the list deleted temporarily is returned back to the original.

### 2) Priority Scan

If the Priority Scan Channel is set up, the Radio proceeds the channel scan in the sequence of P, S1, P, S2, P, S3.... During receiving signal through common channel, the Radio scans the priority channel periodically and if the Radio detects the priority channel, it starts receiving the priority channel. The user can delete (by pressing the EMR key) the current receiving channel temporarily from the scan list and at that time, user can move to the next channel. However, the priority channel will not be deleted..

When transmitting during scan operation, the Radio makes transmission through the channel which is set up by Pc-Programmer.

- Home : Transmit through the channel which is set up.
- Last Receive : Transmit through the latest channel which is finally received.
- Current Scan : Transmit through the channel which is scanning.
- The operation is not possible in Dual PTT Mode.

## 5.7 VOX Function

The VOX function is set up by Pc-Programmer and without pressing the PTT key, the voice signal is transmitted through microphone.

## 5.8 Compander Function

This function is for improving the quality of voice. When transmitting, it transmits compressed voice and when receiving, it expands the compressed voice, which is for improvement of communication quality.

### \* Selection Method of Compander

If turning on power during the PTT + MENU (Scan) key, the conversion sound of Compander Mode is generated and from that time, the Compander function operates. Although the power is turned off and on, the Compander function is maintained.

To release from the Compander function, turn on power during pressing the PTT + MENU (Scan) key once again.

Indication Method : If the Compander function is already set up when turning on power, the green LED is turned on with a sound and after the sound, the green LED is turned off. (If the Scramble function is also set up, the yellow LED lights with a sound and after the sound, the yellow LED is turned off.)

## 5.9 Cloning Function

The Cloning function is to copy the data such as Frequency/Tone/Scan into other Radio.

### \* Cloning Method

- 1) First, prepare the Cloning cable (**PECLONA**) for PX-Series Radio.
- 2) The original Radio should be turned on with pressing the **PTT button** and the Radio to be copied should be in the Standby mode for receiving.
- 3) The yellow LED of original Radio is turned on.
- 4) Connect the Cloning cable to the Ear/Mic. Jacks of 2 Radios.
- 5) If pressing the **"Menu(Scan)" button** of the original Radio, the copy is executed and after completing the copy, the green LED of original Radio lights and if the copy is failed, the red LED is turned on.
- 6) After removing the Cloning cable, turn off and on the power of 2 Radios.  
Finally please use the Radio after checking if the copy is succeeded without problem.

⚠Caution : If the Cloning is made into other maker's Radio, a critical malfunction can happen.

## 5.10 Indication Function of Batter Voltage

In order to check the remaining battery capacity, press the MENU (Scan) + MON key successively at Normal Mode. Then, the LEDs show the followings for 1 second and return back to the original.

- . Green LED is turned on. : satisfaction
- . Yellow LED is turned on. : sufficiency
- . Red LED is turned on. : Shortage
- . Red LED blinks with an alert sound. : Turn-off

## 5.11 Stun / Revive Function

By using this function, it is possible to stun and revive the Radio with Stun ID from the control center which is far apart from the Radio. If Radio receives a Stun ID from the other Radio, the Radio with the Stun ID received lights the green LED and the red LED in turn.

In this state, no key operates. (However, if pressing the PTT key, an alert sound is generated.)

And although the power is turned off and on, this function is maintained.

If Radio receives Revive ID from the other Radio, the Radio returns back to the original with a "beep" sound.

## 5.12 Dual PTT (Home Channel) Function

If pressing the EMR + PTT key successively, the Radio generates a "beep" sound and makes the conversion to the channel designated by PC Program. If Dual PTT function is set up, the function and channel sound of the current channel selection switch are deleted and the Radio is operated by the Dual PTT only.

In order to release from the function, press the EMR + PTT key once again, or turn off and on the power.

- . This function is not operated at the Scan Mode.

## 5.13 Emergency Call Function

If pressing the EMR key, emergency alert sound is heard and the Radio sends the emergency call to the current channel or Home-Channel.

If the Radio is set up in repeat mode, the emergency call sound is heard periodically.

- . This function is not operated at the Scan Mode.



## 5.14 Scramble / Descramble Function

This function is used to protect the PX-Series Radio from overhearing of the other Radio which is using the same frequency.

If turning on the power during pressing the MENU (Scan) + MON key, the conversion sound to Scramble Mode is generated and at this time, Scramble Function is operated.

And although the power is turned off and on, this function is maintained.

In order to release from the Scramble function, press the MENU (Scan) + MON key once again and turn on the power.

Indication Method : If the Scramble function is already set up when turning on power, the red LED is turned on with a sound and after the sound, the red LED is turned off. (If the Componder function is also set up, the yellow LED lights with a sound and after the sound, the yellow LED is turned off.)

## 5.15 Monitor Function

In order to open the squelch compulsorily, press the MON key. If pressing the MON key for more than 2 seconds, the squelch is opened continuously with a “beep” sound. If you want to get out of this mode, press the MON key shortly once again, or turn off and on the power.

## 5.16 BCL/BCLO Function

This function is used not to interrupt the other users who are using the same frequency and by pressing the PTT key, an alert sound is generated.

BCL(Busy Channel Lock) : Limits transmission in case of same frequency.

BCLO(Busy Channel Lock Override) : Limits transmission in case of different sub-tone.

## 5.17 TOT Function

This function is used to prevent from using one channel continuously for a long time. If user exceeds the transmission time which is set by Pc-Programmer, the transmission is stopped and an alert sound is generated. If a Penalty time is set up, the Radio makes transmission normally after the penalty time.

## 5.18 2 Tone Function

In case of 2 Tone channel, the Radio reads the received 2 Tone and if the 2 Tone corresponds with that of my Radio, the Radio receives the corresponding 2 Tone normally. (In case of No Tone or the corresponding Sub-tone)

### 5.19 CTCSS Frequency Table

No.	Frequency	No.	Frequency	. No	Frequency	No	Frequency
1	67.0	15	110.9	29	179.9	43	196.6
2	71.9	16	114.8	30	186.2	44	199.5
3	74.4	17	118.8	31	192.8	45	206.5
4	77.0	18	123.0	32	203.5	46	229.1
5	79.7	19	127.3	33	210.7	47	254.1
6	82.5	20	131.8	34	218.1	48	165.5
7	85.4	21	136.5	35	225.7	49	171.3
8	88.5	22	141.3	36	233.6	50	177.3
9	91.5	23	146.2	37	241.8	51	60.7
10	94.8	24	151.4	38	250.3	52	62.5
11	97.4	25	156.7	39	69.3	53	64.7
12	100.0	26	162.2	40	159.8		
13	103.5	27	167.9	41	183.5		
14	107.2	28	173.8	42	189.9		

## 5.20 DCS Tone Table

No.	DCS Code	No.	DCS Code	No.	DCS Code		
1	023	27	165	53	413	79	731
2	025	28	172	54	423	80	732
3	026	29	174	55	431	81	734
4	031	30	205	56	432	82	743
5	032	31	223	57	445	83	754
6	043	32	226	58	464	84	036
7	047	33	243	59	465	85	053
8	051	34	244	60	466	86	122
9	054	35	245	61	503	87	122
10	065	36	251	62	506	88	212
11	071	37	261	63	516	89	225
12	072	38	263	64	532	90	246
13	073	39	265	65	546	91	252
14	074	40	271	66	565	92	255
15	114	41	306	67	606	93	266
16	115	42	311	68	612	94	274
17	116	43	315	69	624	95	325
18	125	44	331	70	627	96	332
19	131	45	343	71	631	97	356
20	132	46	346	72	632	98	446
21	134	47	351	73	654	99	452
22	143	48	364	74	662	100	454
23	152	49	365	75	664	101	455
24	155	50	371	76	703	102	462
25	156	51	411	77	712	103	523
26	162	52	412	78	723	104	526

### **Acknowledging Special Precautions and the FCC Notice Cautions.**

Modifications not expressly approved by the party responsible for compliance could void the user's authority to operate the equipment.

### **FCC compliance Information**

This device complies with part 15 of FCC Rules.

Operation is subject to the following two conditions: 1. This device may not cause harmful interference, and 2. This device must accept any interference received, including interference that may cause undesired operation.

### **Information to User**

This equipment has been tested and found to comply with the limits for a Class B digital device, Pursuant to part 15 of the FCC Rules. These limits are designed to provide reasonable protection against harmful interference in a residential installation.

This equipment generates, uses and can radiate radio Frequency energy and, if not installed and used in accordance with the instruction, may cause harmful interference to radio communications.

However, there is no guarantee that interference will not occur in a particular installation. If this equipment does cause harmful interference to radio or television reception, which can be determined by turning the equipment off and on, the user is encouraged to try to correct the interference by one or more of the following measures:

- > Reorient or relocate the receiving antenna.
- > Increase the separation between the equipment and receiver
- > Connect the equipment into an outlet on a circuit different from that to which the receiver is connected.

Consult the dealer or an experienced radio/TV technician for help.

## RADIO FREQUENCY ENERGY SAFETY INFORMATION

This UNIMO transceiver has been tested and complies with the standards listed below, in regards to radio Frequency(RF) energy electromagnetic energy(EME) generated by the transceiver

- > FCC RF exposure limits for Occupational use only. RF exposure limits adopted by the FCC are generally based on recommendations from the national council on radiation protection and measurement, & the American National National Standards Institute.
- > FCC OET Bulletin 65 Edition 97-01 Supplement C
- > American National Standards Institute(C95.1-1992)
- > American National Standards Institute(C95.3-1992)

### WARNING

This UNIMO transceiver generates RF EME while transmitting. RF EME(Radio Frequency Electric & Magnetic Energy)has the potential to cause slight thermal, or heating effects to any part of your body less than the recommended distance from this radio transmitter's antenna.

RF energy exposure is determined primarily by the distance to and the power of the transmitting device. In general, RF exposure is minimized when the lowest possible power is used or transmission time is kept to the minimum required for consistent communications, and the greatest distance possible from the antenna to the body is maintain.

The transceiver has been designed for and is classified for Occupational use only. Occupational/controlled exposure limits are applicable to situations in which persons are exposed to RF energy as a consequence of their employment, and such persons have been made aware of the potential for exposure and can exercise control over their exposure.

This means you can use the transceiver only if you are aware of the hazards of operating a transceiver and are familiar in ways to minimize these hazards. This transceiver is not intended for use by the general public in uncontrolled environments.

Uncontrolled environment exposure limits are applicable to situations in which the general public may be exposed to RF energy ,or in which the persons who are exposed as a consequence of their employment may not be fully aware of the potential for exposure or cannot exercise control over their exposure

The following list provides you with the information required to ensure that you are aware of RF exposure and of how to operate this transceiver so that the FCC RF exposure limitations are not exceeded.

- > While transmitting(holding the PTT switch), always keep the antenna at least 2.5cm (1 inches) from your body or face ,as well as from any bystanders

> Do not transmit for more than 50% of the total transceiver use time; transmitting over 50% of the total use time may exceed the limits in accordance to the FCC RF exposure requirements. Nominal transceiver operation is 5% transmission time, 5% reception time, and 90% stand-by time

> Use only the specified antenna for this transceiver; this may be either the antenna provided with the transceiver or another antenna authorized by UNIMO.

Use only UNIMO authorized accessories (antennas, battery packs, belt clips, Speaker/Mics or headsets etc.):

When worn on the body, always place the radio in a UNIMO recommended clip or carrying case meant for this product. The use of other than recommended or approved body-worn accessories may result in RF exposure levels which exceed the FCC's occupational /controlled environment RF exposure limits.

#### **CAUTION**

To ensure that your exposure to RF EME is within the FCC limits for occupational use, you must observe and adhere to the above points.

#### Electromagnetic Interference Compatibility

Electronic devices are susceptible to electromagnetic interference(EMI)if they are not adequately shielded or designed for electromagnetic compatibility. Because this transceiver generates RF energy, it can cause interference to such equipment.

>Turn OFF your transceiver where signs are posted to do so. Hospitals and health care facilities use equipment that is sensitive to electromagnetic radiation.

> Turn OFF your transceiver while on board an aircraft when so instructed, Use of the transceiver must be in accordance with airline regulations and/or crew instructions.