



Maintenance Manual

PZ-series Portable Radio

PZ-400, PZ-100



TABLE OF CONTENTS

SPECIFICATIONS	4
MODEL: PZ-100.....	4
MODEL: PZ-400.....	5
MODEL NUMBER.....	6
PZ-SERIES RADIO PACKAGE NUMBERS	6
FEATURES	7
CONTROLS & INDICATORS	8
Controls	9
Indicators	10
BATTERY PACKS.....	12
Installing the Battery Pack.....	13
Removing the Battery Pack.....	14
Charging the Battery Pack.....	15
CHARGER.....	16
RADIO OPERATIONS.....	17
Installation and Removal of Antenna.....	17
Power On/Off.....	17
Transmission.....	17
Receiving.....	18
Changing Channels.....	18
Adjusting Transmitting Power.....	18

SCAN Operating mode.....	18
Emergency Call	20
VOX	20
Monitor	20
Dual PTT (Home Channel) mode.....	20
Subtone	21
2 Tone Function	23
Call Function	23
Comander.....	24
Scramble	24
Stun / Revive Function	24
BCL/BCLO.....	25
TOT	25
Key Lock	25
Initial.....	25
Whisper mode.....	25
PSC.....	26
Equalizer.....	26
Password.....	26
Language	26
Squelch Level	26
Cloning	26

SPECIFICATIONS

MODEL: PZ-100

GENERAL

Dimensions(Less Antenna) H x W x D	112.2 × 56mm × 31.9 mm
Weight	
Radio (less battery)	
with battery (2600mAH)	
Programmable Channels	16 Channels
Channel Spacing	12.5 / 25 kHz
Power Source	7.5V DC Rechargeable Li-ion 2600 mAH battery pack
Current Drain (maximum)	
Receive Standby mode	60 mA
Receive Full Audio	350 mA
Transmit at 5 Watts	1.6 A

TRANSMITTER

Frequency Range	136 ~ 174 MHz
Frequency Stability	±2.5 ppm (-30 to +60 °C)
RF Power Output	5 Watts / 2 Watts
Spurious and Harmonic	-65dB
FM Hum and Noise	40dB (12.5 kHz), 45dB (25 kHz)
Audio Distortion	5% maximum
Audio Frequency Response	+1, -3dB from 6dB per octave pre-emphasis Characteristic from 300 ~ 3000Hz

RECEIVER

Frequency Range	136 ~ 174 MHz
Sensitivity	.282uV 12 dB SINAD
Squelch Sensitivity	.25uV 10dB SINAD
Selectivity	60dB (12.5KHz), 65dB(25KHz)
Spurious and Harmonic Rejection	70dB
Inter-modulation	60dB
FM Hum and Noise	40dB
Audio Output Power	1 Watt across an 16-ohm load
Audio Distortion	Less than 5% at rated output
Audio Response	+1, -3 dB from 6dB per octave de-emphasis Characteristic from 300 ~ 3000Hz

MODEL: PZ-400**GENERAL**

Dimensions(Less Antenna) H x W x D	112.2 × 56mm × 31.9 mm
Weight	
Radio (less battery)	
with battery (2600mAH)	
Programmable Channels	512 Channels
Channel Spacing	12.5 / 25 kHz
Power Source	7.5V DC Rechargeable Li-ion 2600 mAH battery pack
Current Drain (maximum)	
Receive Standby mode	60 mA
Receive Full Audio	350 mA
Transmit at 5 Watts	1.6 A

TRANSMITTER

Frequency Range	400 ~ 470 MHz
Frequency Stability	±2.5 ppm (-30 to +60 °C)
RF Power Output	4 Watts / 2 Watts
Spurious and Harmonic	-65dB
FM Hum and Noise	40dB (12.5 kHz), 45dB (25 kHz)
Audio Distortion	5% maximum
Audio Frequency Response	+1, -3dB from 6dB per octave pre-emphasis Characteristic from 300 ~ 3000Hz

RECEIVER

Frequency Range	400 ~ 470 MHz
Sensitivity	.282uV 12 dB SINAD
Squelch Sensitivity	.25uV 10dB SINAD
Selectivity	60dB (12.5KHz), 65dB(25KHz)
Spurious and Harmonic Rejection	70dB
Inter-modulation	60dB
FM Hum and Noise	40dB
Audio Output Power	1 Watt across an 16-ohm load
Audio Distortion	Less than 5% at rated output
Audio Response	+1, -3 dB from 6dB per octave de-emphasis Characteristic from 300 ~ 3000Hz

MODEL NUMBER

To identify the model number of PZ-series Radio is as followings

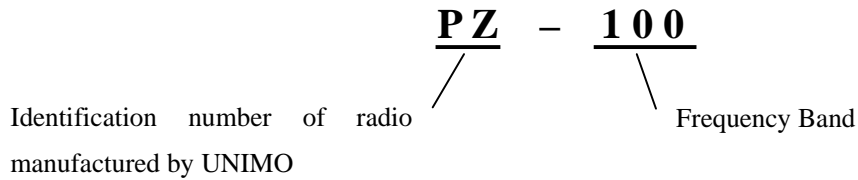

Model Number	Description
PZ - 100	Frequency band: 136 – 174 Mhz,
PZ - 400	Frequency band: 400 – 470 Mhz,

PZ-SERIES RADIO PACKAGE NUMBERS

Package Number	Description
PZ10XXXE	136 – 174Mhz PZ series radio
PZ10GXXE	136 – 174Mhz PZ series radio with GPS
PZ10XBXE	136 – 174Mhz PZ series radio with Bluetooth
PZ10GBXE	136 – 174Mhz PZ series radio with GPS and Bluetooth
PZ10XXWE	136 – 174Mhz PZ series radio (Waterproof model)
PZ10GXWE	136 – 174Mhz PZ series radio with GPS (Waterproof model)
PZ10XBWE	136 – 174Mhz PZ series radio with Bluetooth (Waterproof model)
PZ10GBWE	136 – 174Mhz PZ series radio with GPS and Bluetooth (Waterproof model)
PZ40XXXE	400 – 470Mhz PZ series radio
PZ40GXXE	400 – 470Mhz PZ series radio with GPS
PZ40XBXE	400 – 470Mhz PZ series radio with Bluetooth
PZ40GBXE	400 – 470Mhz PZ series radio with GPS and Bluetooth
PZ40XXWE	400 – 470Mhz PZ series radio (Waterproof model)
PZ40GXWE	400 – 470Mhz PZ series radio with GPS (Waterproof model)
PZ40XBWE	400 – 470Mhz PZ series radio with Bluetooth (Waterproof model)
PZ40GBWE	400 – 470Mhz PZ series radio with GPS and Bluetooth (Waterproof model)

FEATURES

PZ-series radio is designed for a rugged, lightweight and it can be provided for powerful sound and for better performance of conversation distance & sound quality. The new PZ-series radio provides reliable service in the industrial fields and public places for the safety & convenience of users.

The PZ-series radio is offered with several packages available with respect to the options (GPS function, Bluetooth function). The radio is programmed using a Personal computer and program cable connected to the phone jack on the side of the radio.

- 512 channels are selectable.
- Call Guard Squelch of standardized 53 CTCSS / 104 DCS Tones.
- Scramble function of frequency Inverter Type
- Comander function
- Dual Tone Modulation Frequency (DTMF)
- Selectable Channel Spacing (12.5kHz / 25KHz)
- Normal Scanning and Priority Scanning
- Time-Out Timer (TOT)
- 2-Tone Paging
- BCL (Busy Channel Lock) / BCLO (Busy Channel Lock Out)
- High/Low Power Switching
- 10 Step Squelch Control Using RSSI (0~9)
- Remote Radio Stun/Revive (Use 5 Tone)
- Monitor
- VOX
- Easy Cloning
- USB PC Programming
- PC Tuning
- GPS function (Option)
- Bluetooth function (Option)

CONTROLS & INDICATORS

The following section provides a description of the controls and Indicators for the PZ-series radio. Detailed operating instructions can be found the later chapter.

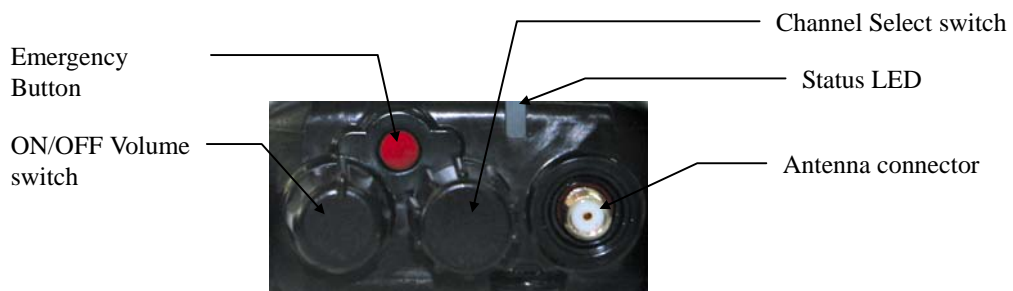

Controls

On/Off Volume Switch

Turn the knob of Volume Switch clockwise to turn the Radio on and if turning the Switch to the opposite direction, the Radio is turned off. The audio volume level can be adjusted by turning the Volume Switch and when adjusting the volume, please refer to the index mark indicated nearby the Volume knob. The knob of volume doesn't exist for the GPS model of PZ-series radio. In this case, press and hold the "F4" button then the radio is turn ON. And during the operation press and hold "F4" button then the radio is turn OFF.

Channel Select Switch

Turn the knob of Channel Select Switch clockwise to increase the channel number and if turning the switch to the opposite direction then decrease the channel number. The channel numbers are pre-programmed using by PC program. The channel selections also can be changed by up and down buttons on front side of the radio.

PTT Button

The radio is converted to transmission mode and transmitting the RF power by pressing and holding the PTT button on the side of the radio. The status indication LED lights in red color. And the radio is converted to receive standby mode by release the PTT button. It is recommended to talk about 5~7cm away from the microphone for using in better sound quality and for better voice communication.

Monitor Button

The receiving status of the selected channel can be checked using by "Monitor" button.

Normal Mode: During the press and holding the "Monitor" button for about 2 seconds, it is possible to check the receiving status of the channel.

Continuous Mode: Press and holding the "Monitor" button for more than 2 seconds, a beep tone is heard along with a noise and the monitor function is continuously maintained. If pressing the Monitor button again, the monitor function will be released.

Emergency Button

Press the "Emergency" button in an emergency situation, an emergency siren sound will be heard through the speaker in the Radio. And the Radio will transmit an emergency signal to the party through the

emergency channel.

Menu Button (Scan Button)

If pressing Menu button for about 2 seconds, the Scan operation is proceeded and by pressing the Menu button again, the Scan operation is released.

Speaker Microphone Jack

The speaker microphone Jack on the side of the radio will be used for interface with external speaker microphone accessories and making PC programming/Cloning/Tuning,

Indicators

Status Indication LED

The users can be recognized the current status of PZ-series radio by the color of LED. The status indication will be as followings.

- When the transmitting status is normal, the red LED will be ON.
- When the receiving status is normal, the green LED will be ON.
- When the CTCSS tone or DCS code is not being received due to mismatch, the green LED will be blinked.
- When the low battery condition, the red LED will be blinked and an alert tone will be generated.
- When the Cloning mode, the orange LED will be blinked.

Graphic LCD

The one line of 14 characters (7 characters for Korean language) graphic type of LCD uses for indication of several kinds of status of the radio. The Group/Channel number or the frequency or the pre-programmed name of the channel will be displayed on the LCD. And provides the menu operation. In addition there are 9 status ICON indicators, also can be displayed the several kinds of status of the radio.

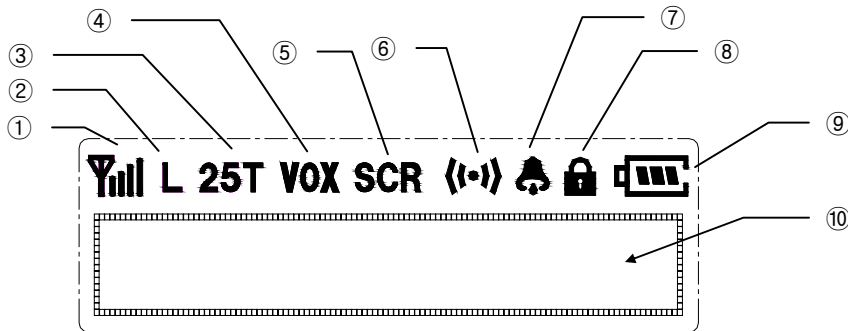

- ① Signal strength indicator is ON when the radio receives RF signal. It can be divided for 4 kinds of signal levels. In case of good signal, all 4 the signal strength indicator bar is ON.
- ② Transmitting power indicator is ON when the Low power mode is selected.
- ③ 2Tone, 5Tone mode indicator is ON when the channel is programmed for 2Tone, 5Tone operation.
- ④ VOX indicator is ON when the VOX mode is activated.
- ⑤ Scrambler mode indicator is ON when the scrambler function is activated.
- ⑥ Compander mode indicator is ON when the compander function is activated.
- ⑦ Radio generates a several kinds of alert tones when the alert tone function is activated. This indicator is OFF when this function is deactivated.
- ⑧ Lock indicator is ON when the radio is locked.
- ⑨ Battery capacity indicator. All the indicators are ON when the battery is full charged. After in use the battery capacity indicator inner the box is OFF one by one. Outer box is blinked when the battery power is low and need to charging
- ⑩ The one line of 14 characters (7 characters for Korean language) graphic LCD area.

The LCD backlighting can be programmed to turn on anytime a button is pressed. It will remain on for a programmable length of time after the button is released. And it may be programmed to remain off all times.

BATTERY PACKS

The following battery pack is available for use with the PZ-series radio.

- PBX-2260LA: Rechargeable Battery Packs (2600mAh Li-ion).

The PX-Series Radio receives power from high-performance Li-ion battery. The battery is safe, of high-performance and highly reliable. Using the enclosed standard charger makes it possible to get sufficient efficiency and lifetime of the battery.

**CAUTION**

Battery Packs used with the PZ-series radio must be supplied by UNIMO Technology Co., Ltd.

Installing the Battery Pack

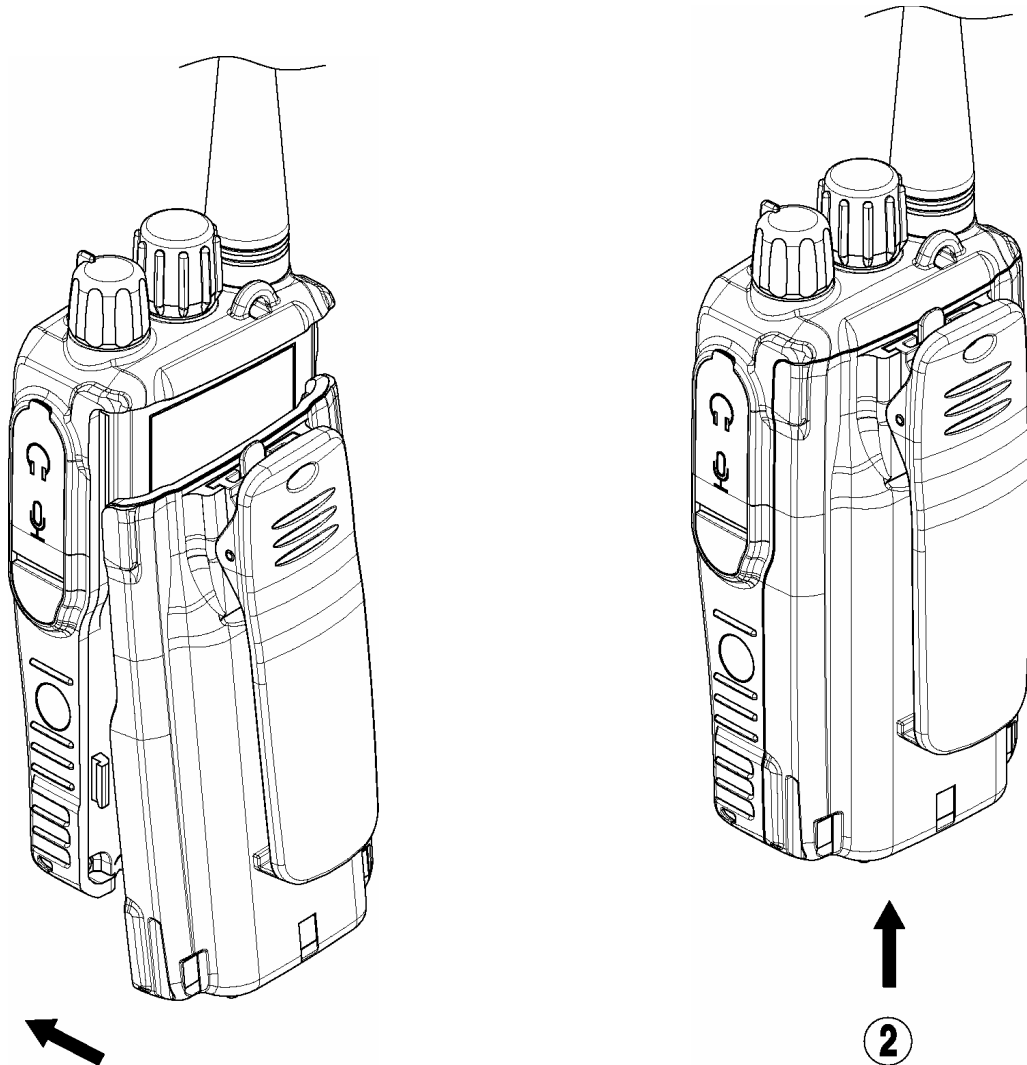

- Ensure the ON/OFF volume switch is set to OFF position of the radio.
- Hold the radio and battery pack with the back of them facing you. See Figure
- Align the hook back of the radio with the hook front side of the battery pack
- Press and slide the battery pack fully upper side of the radio until the battery release latch click into place.

Removing the Battery Pack

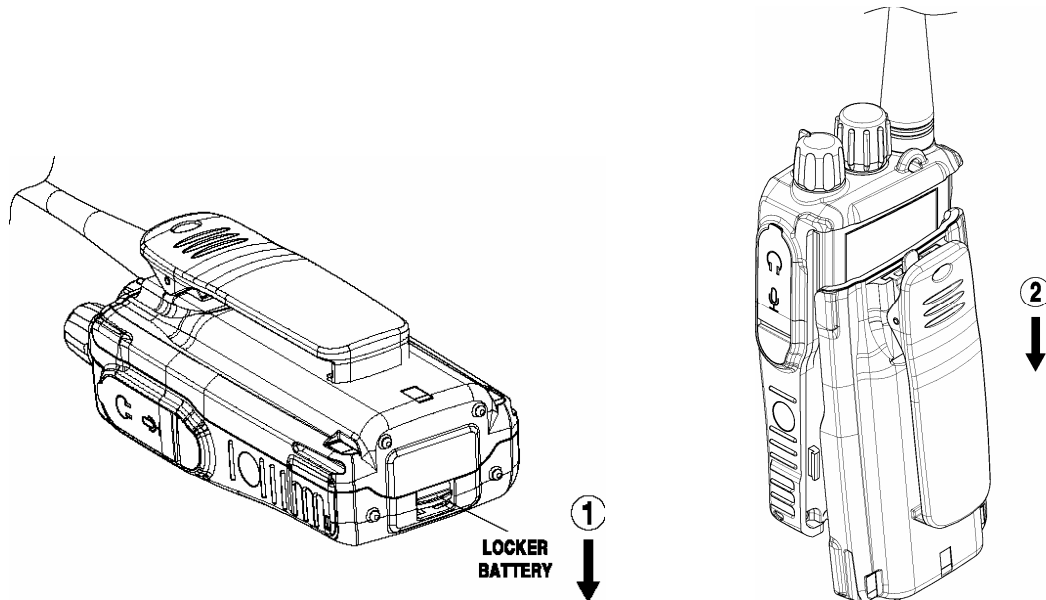

- Ensure the ON/OFF volume switch is set to OFF position of the radio.
- Press down the release latch and slide the battery pack down side of the radio. See Figure

Charging the Battery Pack

New batteries or batteries that have been stored for a long time period of time, should be fully charged before placing into service. Low battery voltage will shorten the talk range and will make the performance of radio worse.

When the battery pack requires charging the battery indicator in the LCD will blink and the radio will sound a high pitch tone every seconds.

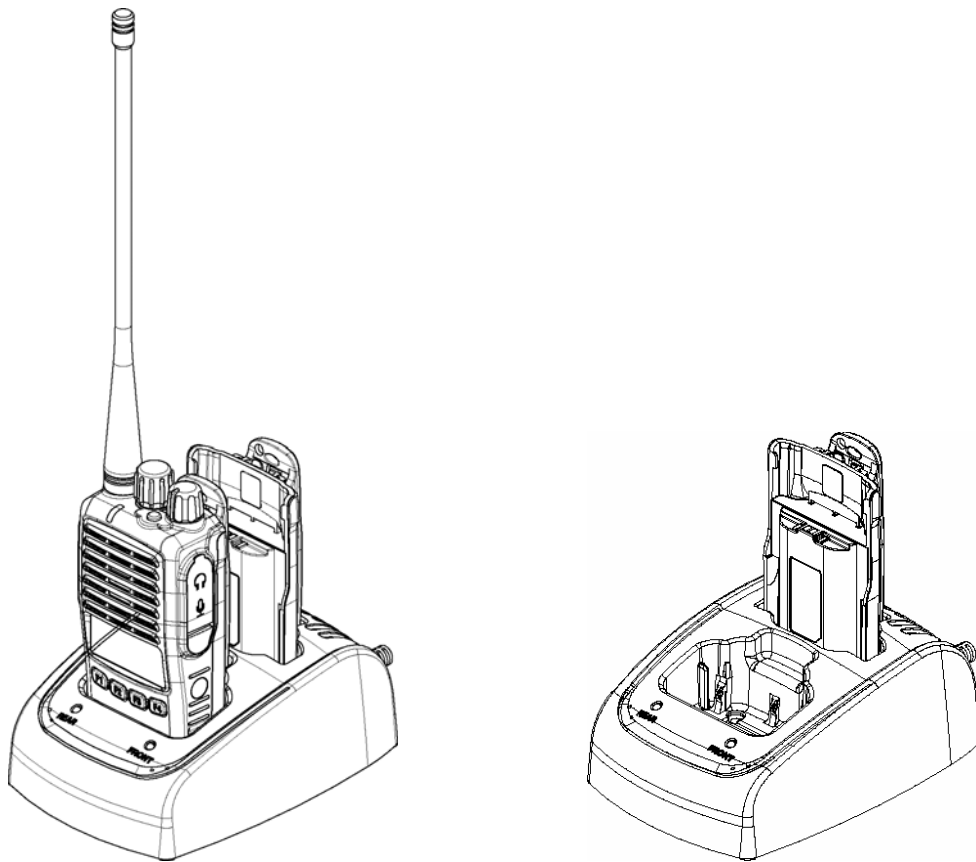

How to Charging

- Plug the charger (CHZ-260FB) into the electricity power outlet for AC220V.
- The charger (CHZ-260FB) has two slots.
- When charging the radio with the battery installed, insert the radio into front slot of the charger after power off.

- When charging the battery only, insert battery into rear slot of the charger.
- Although the green LED is on after full charge, please continue the charging for 30 more minutes for the complete full charge.

During the charging	red LED is turn ON
After complete charging	green LED is turn ON
Error condition	red LED is blinks
During maintaining charge	green LED is turn ON



CAUTION

Charger used with battery packs must be supplied by UNIMO Technology Co., Ltd. Charging the battery on the other manufacturer's can cause unexpected damage of the battery and the radio

CHARGER

The CHZ-260FB is designed for charging the high capacity batteries(PBZ-2260LA) of PZ series radio.



Input Voltage	AC 85V ~ 250V
Battery	PBZ-2260LA, PBZ-2260LB
Rapid Charging Time	In 3 and half hour
Operating Temperature	0 ~ 50 °C
Charging Current	900 mA (Fast Charging)

RADIO OPERATIONS

Installation and Removal of Antenna

Put the antenna into the antenna connector of the radio and turn the antenna clockwise for installation of antenna and in order to remove the antenna from Radio, turn the antenna counterclockwise.



CAUTION

When installation of the antenna, giving a strong pressure to the Radio or pulling the antenna from Radio with a strong power can make damage on the antenna connector, which may cause the Radio to have critical problem.

Power On/Off

Turn Power switch clockwise and as soon as power is supplied, a “beep” sound is heard and the model name of the radio is



displayed and the Radio enters into the previous latest state. If the user ID is pre-programmed than this is displayed on the LCD.



CAUTION

If turning power on by pressing a button on Radio, the Radio may enter into a special mode, in this case, the transmitting and receiving of radio may not be possible. Don't use the Radio for the other purpose apart from the above.

Transmission

Pressing the PTT button on the left side of Radio for transmission. The DTMF or 5 Tone is transmitted according to the setting of the radio. During this time voice communication will not be made and after that the red LED is turned on and voice is transmitted. For voice communication in the best sound quality, it is recommended to talk 5~10cm away from the radio.



CAUTION

If transmitting consecutively for more than a certain time when setting of BCLO function and TOT function, the transmission can be forcibly interrupted for other users.

Receiving

The radio operates as a receiving standby mode except for the transmitting period. User can adjust the volume by using the volume switch. The green LED is turn ON when the radio receives the RF signal and can heard the transmitting voice. According to the setting of transmitting radio, can be heard the DTMF tone or 5 Tone and displayed caller ID on the LCD.

If frequency is same as current channel but sub-tone is not same as current setting than the green LED blinks. In order to check if the current channel is in use, press the Monitor button (M) on the left side of Radio. If pressing the Monitor button (M) for about 2 seconds, the monitor function is activated with a “beep” sound. To release from the monitor function, press the monitor button shortly.

Changing Channels

Channel Switch and “F1”/“F2” buttons are used for changing channels. Turn the Channel switch clockwise or press “F1” button to increase the channel number with beep sound. And Turn the Channel switch counter-clockwise or press “F2” button to decrease the channel number with beep sound. Press and hold “F1”/“F2” button then changing channel continuously. When the channel is changed, channel number or channel names are displayed on the LCD. The channel frequencies include sub-tone information are pre-programmed by PC program.



Adjusting Transmitting Power

The transmitting power can be selected to High-Power mode or Low-Power mode. The user can change the transmitting power on the Menu mode. When Low-Power mode is selected, the indicator icon “L” is displayed on the LCD. By changing the power to Low-power mode under a good communication condition, the user can extend the battery life.



SCAN Operating mode

SCAN function is executed with a “beep” sound when pressing the “F3” and “F2” button consecutively within 0.5 seconds during the standby state. The radio will change the scan channel and check the RF signal at regular interval. Pressing “F4” button then SCAN function can be deactivated.



A scan channel list must be created before SCAN can be used. The radio will not go into SCAN mode where no scan channels are programmed. The scan channel list can be established in PC program of Menu mode.



Normal Scan

Once SCAN is activated, the radio will perform a normal scan mode. When the scan channel list is NS1, NS2 and NS3 on the normal scan mode, the radio proceeds to scan in the sequence of NS1, NS2, NS3, NS1, NS2, NS3.... During the receiving mode user can move to the next channel by pressing the “F1” or “F2” buttons. And delete current receiving channel temporarily from the scan channel list.

If getting out of SCAN Mode or turning on power again, the list deleted temporarily is returned back to the original.

Priority Scan

As soon as priority scan channel is detected, the radio will change priority scan mode. When the scan channel list is NS1, NS2, NS3 and priority scan channel is PS, the radio proceeds to scan in the sequence of PS, NS1, PS, NS2, PS, NS3, PS, NS1....

During receiving signal through common channel, the radio scans the priority channel periodically. And if the radio detects the signal on the priority channel, it starts to receive the signal from the priority channel.

During the receiving mode user can move to the next channel by pressing the “F1” or “F2” buttons. The user can delete current receiving channel temporarily from the scan list and at that time, user can move to the next channel. But the radio receives the signal from priority channel then it will not be deleted.

Transmitting

Pressing the PTT button cause the radio to transmit on selected channel frequency and to stop the SCAN mode. And the selected channel frequency can be established in PC programmer.

- Home channel.
- Last receiving channel
- Current scan channel.

Emergency Call

If pressing the EMR key, radio transmitting the emergency alert tone or 5-Tone message in Sell-call mode. Also user can hear the emergency alert tone. If the radio is set up in repeated mode, the radio transmitting the emergency alert tone periodically. This function can be performed when SCAN is activated.



VOX

The VOX function is set up by Pc-Programmer and without pressing the PTT key, the voice signal is transmitted through microphone.



Monitor

In order to open the squelch compulsorily, press the MON key. If pressing the MON key for more than 2 seconds, the squelch is opened continuously with a “beep” sound. If you want to get out of this mode, press the MON key shortly once again, or turn off and on the power.

Dual PTT (Home Channel) mode

If pressing the “F3” + PTT key successively, the radio generates a “beep” sound and makes the conversion to the HOME channel designated by PC Programmer. “[HM]” message is displayed on the left side of the LCD. In order to release from the Dual PTT function, press the EMR + PTT key once again, or turn off and on the power. This function can be performed when SCAN is activated.



Subtone

The radio can be programmed for CTCSS encode/decode tone frequencies and DCS code.

CTCSS tone frequency

A list of standard tone frequencies for CTCSS tone are as shown below.

No.	Frequency	No.	Frequency	No.	Frequency	No.	Frequency
1	67.0	15	110.9	29	179.9	43	196.6
2	71.9	16	114.8	30	186.2	44	199.5
3	74.4	17	118.8	31	192.8	45	206.5
4	77.0	18	123.0	32	203.5	46	229.1
5	79.7	19	127.3	33	210.7	47	254.1
6	82.5	20	131.8	34	218.1	48	165.5
7	85.4	21	136.5	35	225.7	49	171.3
8	88.5	22	141.3	36	233.6	50	177.3
9	91.5	23	146.2	37	241.8	51	60.7
10	94.8	24	151.4	38	250.3	52	62.5
11	97.4	25	156.7	39	69.3	53	64.7
12	100.0	26	162.2	40	159.8		
13	103.5	27	167.9	41	183.5		
14	107.2	28	173.8	42	189.9		

DCS code

A list of standard tone frequencies for CTCSS tone are as shown below.

No.	DCS Code	No.	DCS Code	No.	DCS Code	No.	DCS Code
1	023	27	165	53	413	79	731
2	025	28	172	54	423	80	732
3	026	29	174	55	431	81	734
4	031	30	205	56	432	82	743
5	032	31	223	57	445	83	754
6	043	32	226	58	464	84	036
7	047	33	243	59	465	85	053
8	051	34	244	60	466	86	122
9	054	35	245	61	503	87	122
10	065	36	251	62	506	88	212
11	071	37	261	63	516	89	225
12	072	38	263	64	532	90	246
13	073	39	265	65	546	91	252
14	074	40	271	66	565	92	255
15	114	41	306	67	606	93	266
16	115	42	311	68	612	94	274
17	116	43	315	69	624	95	325
18	125	44	331	70	627	96	332
19	131	45	343	71	631	97	356
20	132	46	346	72	632	98	446
21	134	47	351	73	654	99	452
22	143	48	364	74	662	100	454
23	152	49	365	75	664	101	455
24	155	50	371	76	703	102	462
25	156	51	411	77	712	103	523
26	162	52	412	78	723	104	526

2 Tone Function

The radio encodes the received 2 Tone before receiving the transmission voice when current channel is activated 2 Tone. If the 2 Tone corresponds with that of current channel then radio receives the corresponding 2 Tone normally. (In case of No Tone or the corresponding Sub-tone)

Call Function

The radio can be called the individual radio or Group of radio using by 5 Tone of Call Function. The radio can be programmed for 200 different IDs and names using by PC programmer.

The radio enters Call mode when pressing the “F3” and “F1” button simultaneously during the standby mode. When the Call mode is activated then call IDs are displayed on the LCD and change next IDs using by channel select switch. And press “F1” button the call the individual or group of radio. Press “F3” button then transmitting the reset tone. If user doesn’t select a ID of called radio then display “No Rx ID” on the LCD screen.

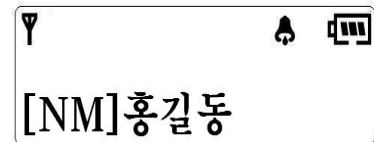

The radio returns the standby mode when pressing the “F4” button.

The call mode can’t be activated when the caller’s ID doesn’t program into the radio.

Individual Call

- Enters the Call mode using by press the “F3” and “F1” buttons simultaneously.
- Select the Call ID that the user wants to communicate.
- To initiate a call, the user press the “F1” button then the radio transmits the calling signal. And the caller’s ID was displayed on receiving radio. The receiving radio enters the Call mode when receives the calling signal.

Individual Communication

- Enters the Call mode using by press the “F3” and “F1” buttons simultaneously.
- Select the Call ID that the user wants to communicate.
- To initiate a communication, the user press the PTT key then the radio transmits the calling signal after that transmitting the voice.

Group Call

- Enters the Call mode using by press the “F3” and “F1” buttons simultaneously.
- Select the Group Call ID that the user wants to communicate. The Group IDs can be programmed using by PC programmer.
- To initiate a call, the user press the “F1” button then the radio transmits the calling signal. And the caller’s Group ID was displayed on receiving radios.

Group Communication

- Enters the Call mode using by press the “F3” and “F1” buttons simultaneously.
- Select the Group Call ID that the user wants to communicate.
- To initiate a communication, the user press the PTT key then the radio transmits the calling signal after that transmitting the voice.

Compander

The compander function is used for improving the voice quality. When transmitting, it transmits compressed voice and when receiving, it expands the compressed voice, which is for improvement of communication quality.



Scramble

The scramble function is used to protect the radio from overhearing of the other radio that is used same frequency. The scramble can be activated by Menu mode. Although the power is turned off and on, this function is maintained. Indicator Icon “SCR” is ON when the scramble is activated.

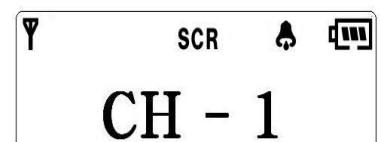

Stun / Revive Function

It is possible to stun and revive the radio with Stun ID from the control center. If the radio receives Stun ID then all of the key and buttons of the radio doesn’t perform. In this state, pressing the PTT buttons then can be heard alert sound. And although the power is turned off and on, this state is maintained.



If the radio receives Revive ID from the other radio, the Radio returns back to the original with a "beep" sound.

BCL/BCLO

BCL/BCLO function is used not to interrupt the other users who are using the same frequency. If BCL/BCLO is activated then transmitting is prohibited from the same channel that was used for others. In this case, alert sound is heard and message is displayed on the LCD.

BCL(Busy Channel Lock) : Prohibit transmission from the same frequency.

BCLO(Busy Channel Lock Override) : Prohibit transmission in case of different sub-tone.

TOT

TOT function is used to prevent from using one channel continuously for a long time. If the radio transmits over the TOT time continuously, the transmitting is automatically stopped and an alert sound is generated. If a Penalty time is set up then the radio makes transmitting normally after the penalty time. The TOT and penalty time can be setup by PC programmer.

Key Lock

Pressing and holding the "F4" buttons over 2 seconds then Key Lock is activated when the radio is standby mode. And the indicator Icon is ON. Up/Down and Menu buttons doesn't operate during this function is activated. Key Lock function can be deactivated, pressing the "F4" buttons once more when the Key Lock is activated.



Initial

The radio should be turn on with pressing the "F3" button. The radio can be initialized the setting of the function by user. And display "INITIAL" on the LCD screen.

Whisper mode

It can be possible to amplify the very low voice for the normal transmitting voice. It can be changed on the PC programmer or Menu mode on the radio.

PSC

It can be increased the battery lifetime when the PSC function is activated. It can be changed on the PC programmer or Menu mode on the radio.

Equalizer

It can be possible to emphasize the high or low frequency band of the receiving audio. It can be changed on the PC programmer or Menu mode on the radio.

Password

User can be set the password into the radio. The password input screen is displayed on the LCD screen when turn the radio power on. When the user put in the correct password then the radio is activated. It can be changed on the PC programmer or Menu mode on the radio.

Language

User can be selected the language of the radio. It can be changed on the PC programmer or Menu mode on the radio.

Squelch Level

The user can be set the 9 different squelch level on the radio. It can be changed on the PC programmer or Menu mode on the radio.

Cloning

The personality data of radio such as frequency/Tone/Scan can be copied to other radio directly using by cloning function. The following section provides a description of 2 different kind of cloning function.

Wire Cloning

- Prepare the cloning cable (PECLONA) for PZ-series radio.
- The original radio should be turned on with pressing the PTT button and the radio to be copied should be in the standby mode for receiving.
- “Clone(Line)” message will be displayed on the LCD screen of the original radio.

CLONE(LINE)

- Ear/Microphone jack of original radio connect to the target radio through cloning cable.
- If pressing the “F3” button of the original radio, the copy is executed. After completing the copy, “Clone complete” message will be displayed on the LCD.

Removing the cloning cable, turn off and on the power of 2 Radios. Please use the radio after checking if the copy is succeeded without problem.

Wireless Cloning

- The original radio should be turned ON with pressing the Monitor button and press “F1” button then radio is ready to set the transmitting mode. “CLONE(TX)” message will be displayed on the LCD screen.

CLONE (TX)

- The radios to be copied should be turned ON with pressing the Monitor button and press “F2” button then radios are ready to set the receiving mode. “CLONE(RX)” message will be displayed on the LCD screen.

CLONE (RX)

- The copy is executed when pressing the “F3” button of the original radio.
- After completing the copy, “complete” message will be displayed on the LCD screen.



CAUTION

If the Cloning is made into other maker’s Radio, a critical malfunction can happen.

Acknowledging Special Precautions and the FCC Notice Cautions.

Modifications not expressly approved by the party responsible for compliance could void the user's authority to operate the equipment.

FCC compliance Information

This device complies with part 15 of FCC Rules.

Operation is subject to the following two conditions: 1. This device may not cause harmful interference, and 2. This device must accept any interference received, including interference that may cause undesired operation.

Information to User

This equipment has been tested and found to comply with the limits for a Class B digital device, Pursuant to part 15 of the FCC Rules. These limits are designed to provide reasonable protection against harmful interference in a residential installation.

This equipment generates, uses and can radiate radio Frequency energy and, if not installed and used in accordance with the instruction, may cause harmful interference to radio communications.

However, there is no guarantee that interference will not occur in a particular installation. If this equipment does cause harmful interference to radio or television reception, which can be determined by turning the equipment off and on, the user is encouraged to try to correct the interference by one or more of the following measures:

- > Reorient or relocate the receiving antenna.
- > Increase the separation between the equipment and receiver
- > Connect the equipment into an outlet on a circuit different from that to which the receiver is connected.

Consult the dealer or an experienced radio/TV technician for help.

RADIO FREQUENCY ENERGY SAFETY INFORMATION

This UNIMO transceiver has been tested and complies with the standards listed below, in regards to radio Frequency(RF) energy electromagnetic energy(EME) generated by the transceiver

- > FCC RF exposure limits for Occupational use only. RF exposure limits adopted by the FCC are generally based on recommendations from the national council on radiation protection and measurement, & the American National National Standards Institute.
- > FCC OET Bulletin 65 Edition 97-01 Supplement C
- > American National Standards Institute(C95.1-1992)
- > American National Standards Institute(C95.3-1992)

WARNING

This UNIMO transceiver generates RF EME while transmitting. RF EME(Radio Frequency Electric & Magnetic Energy)has the potential to cause slight thermal, or heating effects to any part of your body less than the recommended distance from this radio transmitter's antenna.

RF energy exposure is determined primarily by the distance to and the power of the transmitting device. In general, RF exposure is minimized when the lowest possible power is used or transmission time is kept to the minimum required for consistent communications, and the greatest distance possible from the antenna to the body is maintain.

The transceiver has been designed for and is classified for Occupational use only. Occupational/controlled exposure limits are applicable to situations in which persons are exposed to RF energy as a consequence of their employment, and such persons have been made aware of the potential for exposure and can exercise control over their exposure.

This means you can use the transceiver only if you are aware of the hazards of operating a transceiver and are familiar in ways to minimize these hazards. This transceiver is not intended for use by the general public in uncontrolled environments.

Uncontrolled environment exposure limits are applicable to situations in which the general public may be exposed to RF energy ,or in which the persons who are exposed as a consequence of their employment may not be fully aware of the potential for exposure or cannot exercise control over their exposure

The following list provides you with the information required to ensure that you are aware of RF exposure and of how to operate this transceiver so that the FCC RF exposure limitations are not exceeded.

- > While transmitting(holding the PTT switch), always keep the antenna at least 2.5cm (1 inches) from your body or face ,as well as from any bystanders

> Do not transmit for more than 50% of the total transceiver use time; transmitting over 50% of the total use time may exceed the limits in accordance to the FCC RF exposure requirements. Nominal transceiver operation is 5% transmission time, 5% reception time, and 90% stand-by time

> Use only the specified antenna for this transceiver; this may be either the antenna provided with the transceiver or another antenna authorized by UNIMO.

Use only UNIMO authorized accessories (antennas, battery packs, belt clips, Speaker/Mics or headsets etc.):

When worn on the body, always place the radio in a UNIMO recommended clip or carrying case meant for this product. The use of other than recommended or approved body-worn accessories may result in RF exposure levels which exceed the FCC's occupational /controlled environment RF exposure limits.

CAUTION

To ensure that your exposure to RF EME is within the FCC limits for occupational use, you must observe and adhere to the above points.

Electromagnetic Interference Compatibility

Electronic devices are susceptible to electromagnetic interference(EMI)if they are not adequately shielded or designed for electromagnetic compatibility. Because this transceiver generates RF energy, it can cause interference to such equipment.

>Turn OFF your transceiver where signs are posted to do so. Hospitals and health care facilities use equipment that is sensitive to electromagnetic radiation.

> Turn OFF your transceiver while on board an aircraft when so instructed, Use of the transceiver must be in accordance with airline regulations and/or crew instructions.

IMPORTANT Safety Instruction:

CAUTION

To reduce the risk of electric shock, do not remove the top cover (or the rear section).
No user serviceable parts inside, refer servicing to qualified personnel.



This symbol, wherever it appears, alerts you to the presence of uninsulated dangerous voltage inside the enclosure-voltage that may be sufficient to constitute a risk of sock.



This symbol, wherever it appears, alerts you to the important operating and maintenance instructions in the accompanying literature. Please read the manual.

- 1) Read these instructions.
- 2) Keep these instructions.
- 3) Heed all warnings.
- 4) Follow all instructions.
- 5) Do not use this equipment near water.
- 6) Do not using near any heat sources such as radiators, heat resisters, stove, or other equipment that produce heat.

CAUTION
RISK OF EXPLOSION IF BATTERY IS REPLACED
BY AN INCORRECT TYPE.
DISPOSE OF USED BATTERIES ACCORDING
TO THE INSTRUCTIONS

European Union Regulatory Notice

Compliance with these directives implies conformity to harmonized European standards (European Norms) that are listed in the EU Declaration of Conformity issued by HP for this product or product family. This compliance is indicated by the following conformity marking placed on the product.



CE RF Radiation Exposure Statement:

Caution This equipment complies with European RF radiation exposure limits set forth for an uncontrolled environment. This equipment should be installed and operated with a minimum distance of 20 centimeters between the radiator and your body. This transmitter must not be co-located or operating in conjunction with any other antenna or transmitter.