



# UDM-240ZBV,ZV

## Service Manual



**※ BEFORE USING THIS...**

♣ Please read this manual in detail before using the device. (Please read and understand the manual before using this equipment)

♣ Features can be subject to change or modify without any prior notice for its improvement of performance (better performance)

♣ Copyright of this manual belongs to UNIMO Technology Co., Ltd., in a whole or in part authorized copy or modify are prohibited.

♣ Pictures on this manual may differ from the actual products.

♣ Please contact our local agency or Unimo A/S division directly if you have any questions.

## Safety Precautions

This content is for user's safety and property. Please read it and fully understand.

Details affect to its performance and appearance



**Please use recommended voltage for input power supply voltage.**



**Adapter, external ear-phones are designed to be used for Unimo product only. Using non-Unimo goods can cause damage or malfunction to the product.**



**Please use communication purpose only.**



**Please do not disassemble or modify the product.  
Damage or malfunction caused by those, won't be repaired free of charge.**

※ Avoid severe impact to the product.

※ Please keep avoid being exposed to direct sunlight or high temperatures and a lot of humidity

Details affect to the operation of radios or other equipments.

Communication range can be shortened near the products using 2.4GHz due to interference of electric wave.

(Microwave, Wi-Fi, Computer, other equipment using 2.4GHz,... etc.)



Turn off the radio on airplane. Please follow the instructions or rules when you use it.



Please check whether can use or not before using the radio the due to electronic effect.



Do not use the radios near electronic equipments such as Wi-Fi or computers. Radios may does not work properly due to strong interference.

※ Electromagnetic waves in a variety of electrical and electronic equipment can be occurred. The influence of electromagnetic interference is generated. Distance calls can also be shortened remarkably.

### Safety Requirement

Please read the following information about safe and effective use of the product.



Keep your distance at least 1 inch(2.5cm) from your body when you use the radios.



Make sure the regulations regarding the use of radio while driving, please do not use the radios as much as possible while you drive.  
Use additional accessories, such as earphones, for your safety.



Do not listen at very high volume. Your hearing may be affected.



For use in hazardous areas, only explosion-proof device must be used. If an electrical spark pops up in hazardous areas, it can cause severe burns or death.



Turn it off around the workplaces, causing an explosion of electromagnetic behavior of the product. e

## 1 FEATURES

**UDM-240ZH is designed to have light and durable structure and it provides a powerful sound.**

**It is the first product using 2.4GHz band developed in Korea and provides a clear digital sound.**

**It is designed to provide adequate service for industrial products, public safety users.**

**It also provides clear digital radio communication between the UDM-240ZV and can be operated with the existing VHF, UHF, TETRA vehicle and base station if it's interfaced with them.**

- **16 Channels (11~26)**
- **Perfect security. (AES 128bit)**
- **3 levels of audio adjustment**
- **Application of high sensitivity of external antenna**
- **Designation of group ID up to 64,000**
- **1 to N communication (per Channel/ Group ID)**

## 2 COMPONENTS

### Basic components

- Main unit, External antenna, Interface cable, Power supply, User manual, Interface manual

### Optional components

- Programming software
- USB PC Programming cable

\*\*\* Components can be changed according to the request.

### 3 DESCRIPTION

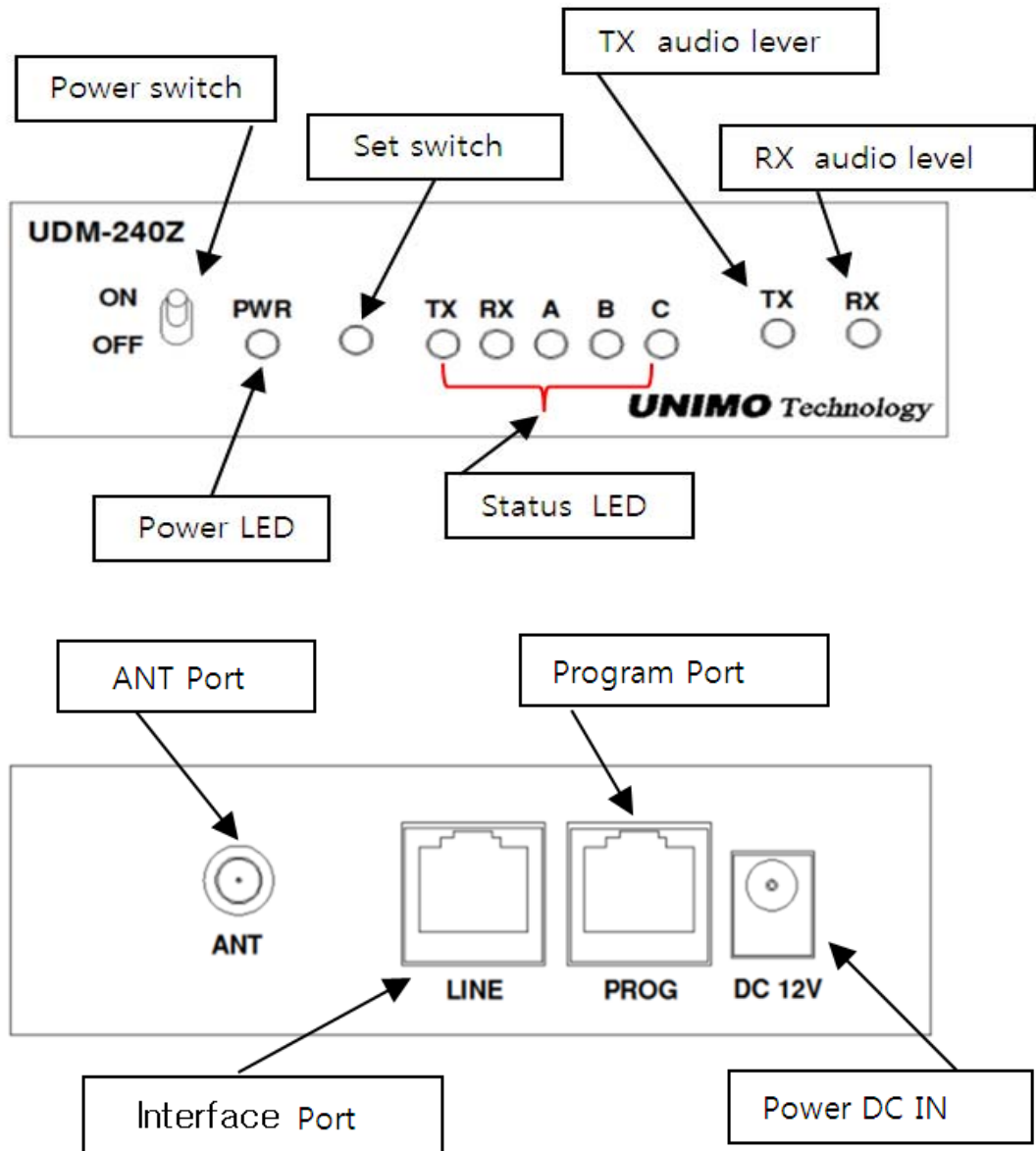



Power On/Off switch

**Supply or shut the main power to the unit.**

Set switch

**Enables user to set operating channel and audio level.**

ANT port

**Connect the external antenna to this port.**

LINE port

**Connect the interface cable to a mobile radio you are going to use.**

PROG port

**It is a port for upgrading the firmware of the device. (for engineer)**

DC IN

**Supply power to the main unit. (UDM-240ZV : 12V~13.8V, UDM-240ZBV : 12V~40V)**

## Status Display

### LED

The users can be recognized the current status by LED indicator on the top of the UDM.

The status indication will be as followings.

- **PWR** : red LED will be on if the power is being supplied
- **TX** : it indicates the receiving status of the device and red LED will be on while transmitting through a mobile radio connected to the device.
- **RX** : It indicates the transmitting status of the device and green LED will be blinking while receiving through a mobile radio connected to the device.
- **A** : It indicates operating channel and audio level.(amber LED)
- **B** : It indicates operating channel and audio level.(green LED)
- **C** : It indicates operating channel and audio level.(red LED)

## 4 HOW TO SET FOR OPERATION

### 4.1 Power ON/OFF

- Turn the device on by the power switch.

### 4.2 Operating channel

Press the setup switch for more than 3 seconds and select the channel according to the below table. After select the channel, if you press the setup switch for 3 seconds again, all the LED will be blinking once and the selected channel will be confirmed.

RX(Green)	A(Yellow)	B(Green)	C(Red)	CH
▶	▶	▶	▶	11 CH
▶	▶	▶	◻	12 CH
▶	▶	◻	▶	13 CH
▶	▶	◻	◻	14 CH
▶	◻	▶	▶	15 CH
▶	◻	▶	◻	16 CH
▶	◻	◻	▶	17 CH
▶	◻	◻	◻	18 CH
◻	▶	▶	▶	19 CH
◻	▶	▶	◻	20 CH
◻	▶	◻	▶	21 CH
◻	▶	◻	◻	22 CH
◻	◻	▶	▶	23 CH
◻	◻	▶	◻	24 CH
◻	◻	◻	▶	25 CH
◻	◻	◻	◻	26 CH

### 4.3 Audio Level

#### TX,RX AUDIO LEVEL SETTING



<b>Level change</b>	<p>While pressing the setup switch, turn the UDM-240ZV on and keep pressing the switch for more than 3 seconds. Then, four LED(PWR,A,B,C) will be blinking once and current level of LED will be on.</p> <p>Select the level by pressing the setup switch and press it again for 3 seconds to save the level you select. Then, the four LED will be blinking once again and the level will be saved.</p>
---------------------	--

## 5 INTERFACE

### Line Port: Connection with an external port



#### UDM-240ZV LINE

8		- GND
7		- Hi-PTT(Output)
6		- Low-PTT(Output)
5		- DISC(Audio input)
4		- Hi-Busy(input)
3		- MIC(Audio-output)
2		- Low-Busy(input)
1		- N.C

#### UDM-240ZV PROG

8		- +5V
7		- DATA-RX
6		- DATA-TX
5		- ISP
4		- GND
3		- N.C
2		- MIC
1		- PTT

UDM-240ZV Front



UDM-240ZV Back



#### UDM-240ZV Ext Function

8		- GND
7		- Hi-PTT(Output)
6		- Low-PTT(Output)
5		- DISC(Audio-input)
4		- Hi-Busy(input)
3		- MIC(Audio-output)
2		- Low-Busy(input)
1		- N.C

#### UDM-240ZV Ext Cable Color



UNIMO UDM-240ZV Ext Interface Cable

UDM-240ZV/ZBV

PROG port

**UNIMO** UDM-240ZH/240ZV Program



**UNIMO** UDM-240ZH/240ZV Program

"Device-Programmer 3.54" Run the program.

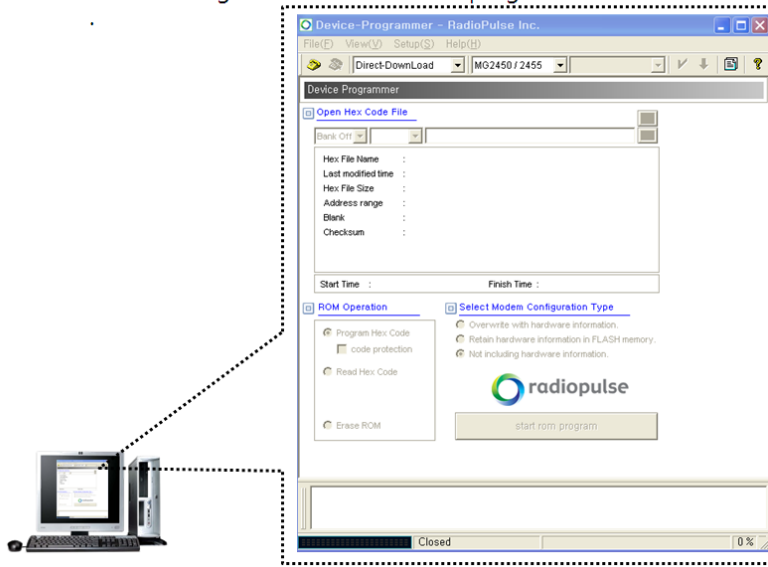

UDM-240ZV/ZBV



### UDM-240ZH/240ZV Program

"Telephone icon", select the Port Settings mode.

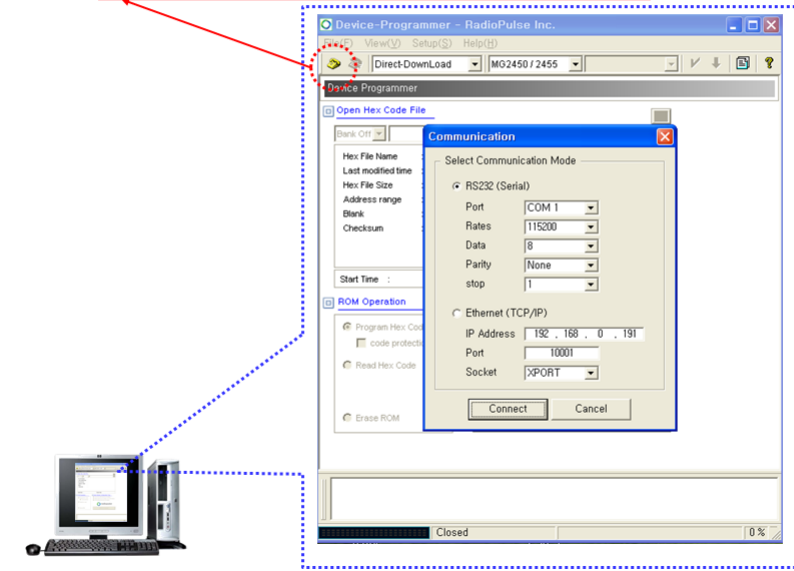

### UDM-240ZH/240ZV Program

Select the port to be used.

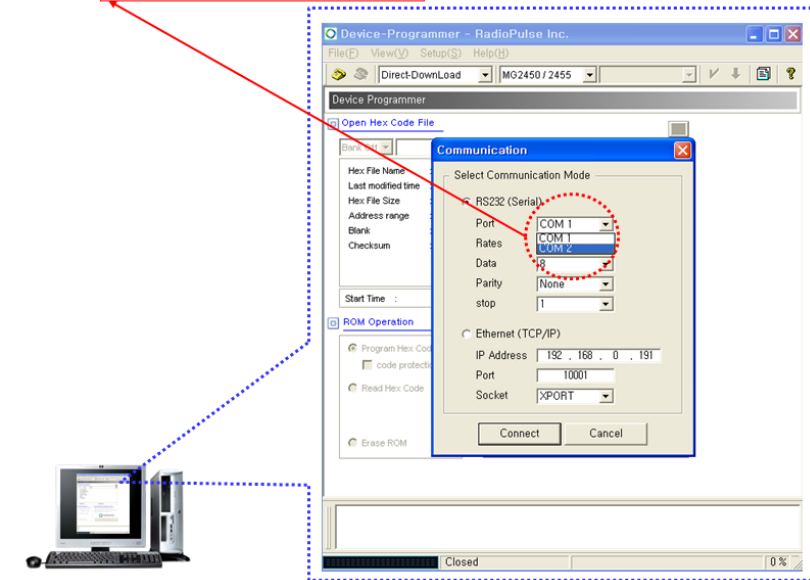

### UDM-240ZV/ZBV



UDM-240ZH/240ZV Program

1. Select the Program mode "Overwrite with hardware information"

2. Advanced menu window will appear.

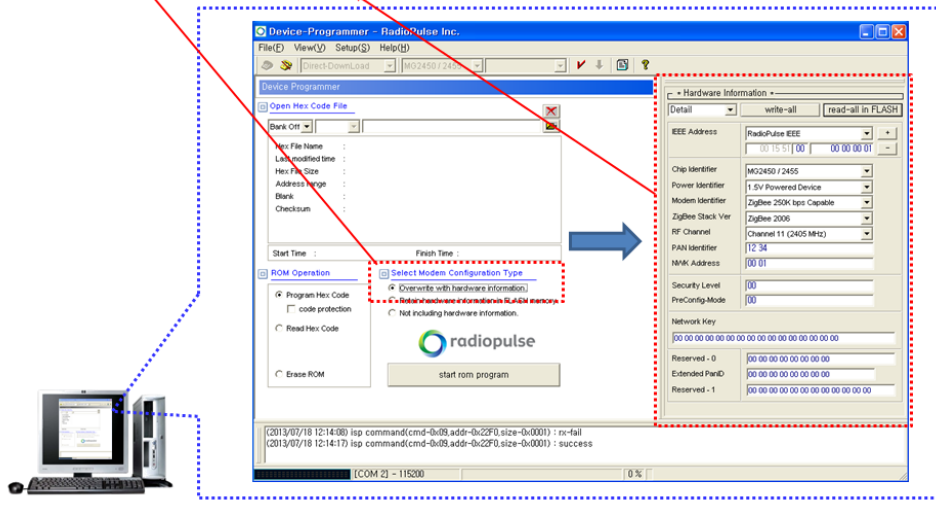





UDM-240ZH/240ZV Program

1. "read-all in FLASH" The program reads the value of the products connected to

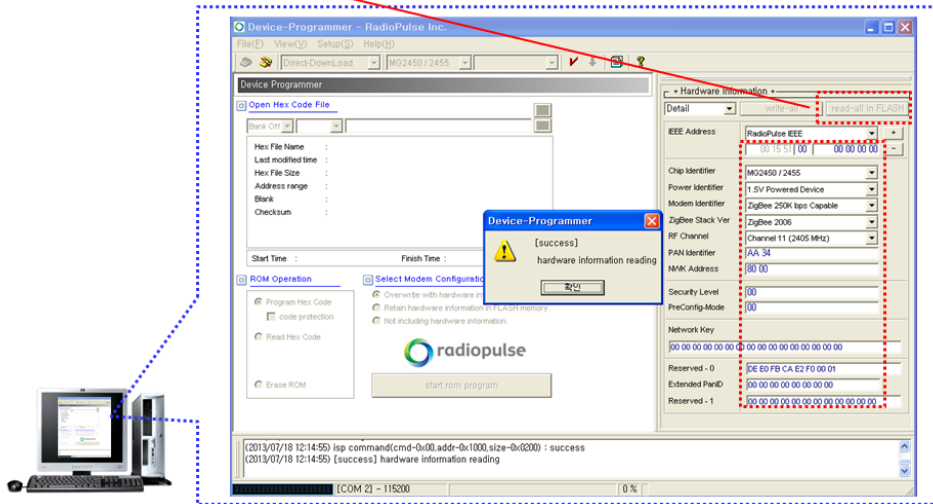



UDM-240ZH/240ZV Program

Flash parameter values

The screenshot shows the 'Hardware Information' window of the UDM-240ZH/240ZV program. A red box highlights the 'Flash parameter values' section, which includes fields for IEEE Address, Chip Identifier, Power Identifier, Modem Identifier, ZigBee Stack Ver, RF Channel, PAN Identifier, NWK Address, Security Level, PreConfig-Mode, Network Key, Reserved - 0, Extended PanID, and Reserved - 1. A warning dialog box is overlaid on the main window, indicating that certain parameters should not be changed arbitrarily.



UDM-240ZH/240ZV Program

"Warning" If the parameter value should not be changed arbitrarily

This screenshot is similar to the one above, but with red boxes highlighting specific parameters in the 'Hardware Information' window: IEEE Address, Chip Identifier, Power Identifier, Modem Identifier, ZigBee Stack Ver, RF Channel, PAN Identifier, NWK Address, Network Key, and Reserved - 0. Red arrows point from the warning dialog to these highlighted parameters, indicating that they should not be changed arbitrarily.

UDM-240ZV/ZBV



UDM-240ZH/240ZV Program

UDM-240ZV Program

Change the parameter values set group ID(00~99)

3. UDM-240ZV  
TX Microphone Input  
Level A, B, C Set
- DC
  - E4
  - E6
  - EB
  - F0
  - F5
  - FA
  - FF (maximum)

2. UDM-240ZV  
Rx Audio Input  
Level A,B,C Set
- DC
  - E4
  - E6
  - EB
  - F0
  - F5
  - FA
  - FF (maximum)



UDM-240ZH/240ZV Program

UDM-240ZH Program

Change the parameter values set group ID(00~99)

2. UDM-240ZH  
Rx Audio Output  
Volume value of  
standby Level Set
- 01
  - 02
  - 03
  - 04
  - 05
  - 06
  - 07
  - 08 (maximum)

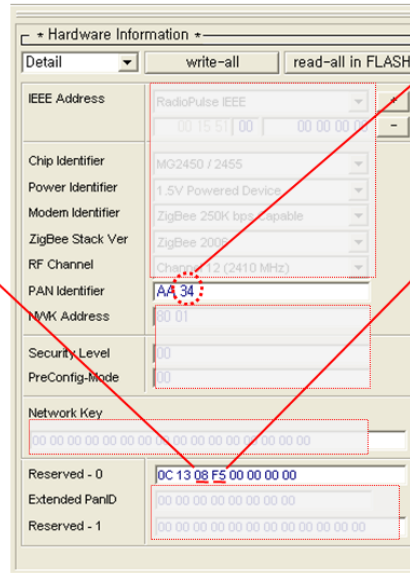

3. UDM-240ZH  
TX Microphone Output  
Level A, B, C Set
- DC
  - E4
  - E6
  - EB
  - FO
  - F5
  - FA
  - FF (maximum)



UDM-240ZH/240ZV Program

Searches for a reference source.

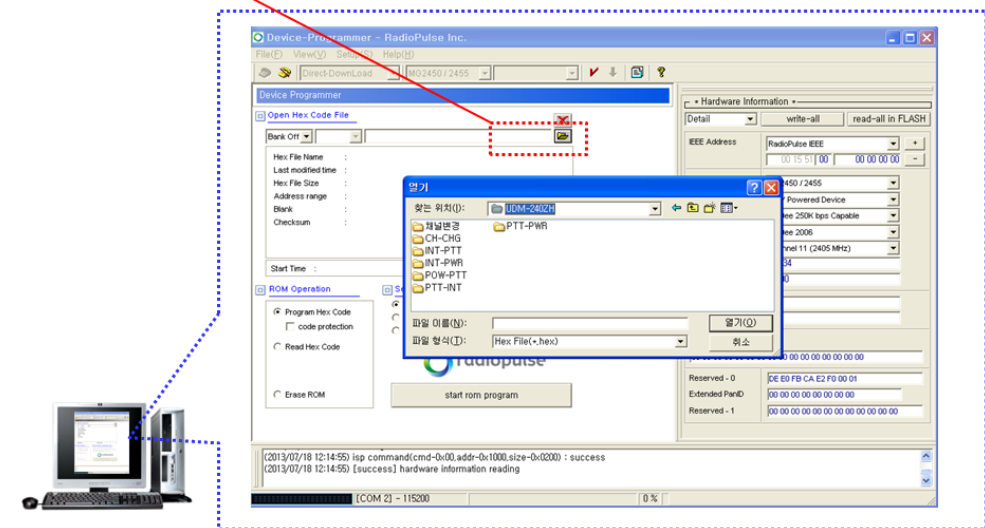

UDM-240ZV/ZBV



### UDM-240ZH/240ZV Program

Selects the program source to be

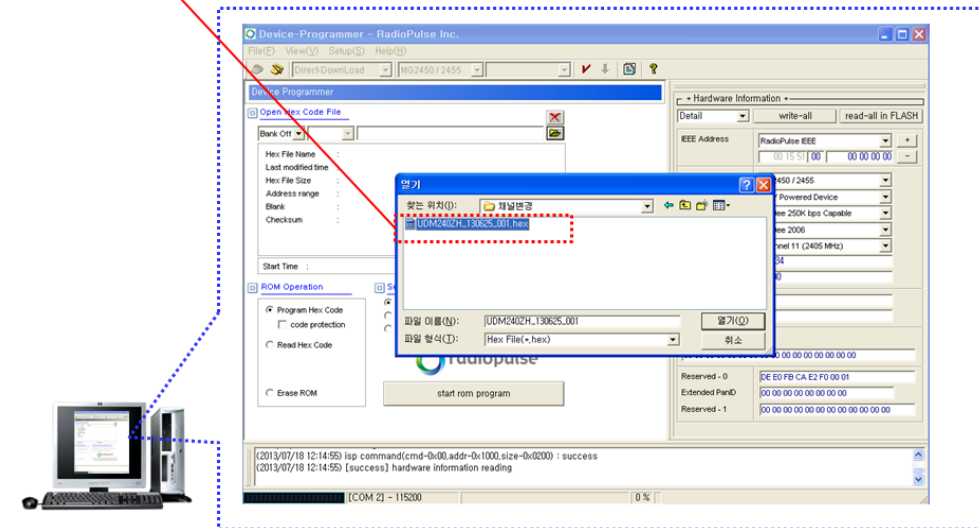



UDM-240ZH/240ZV Program

"Start rom program" Run

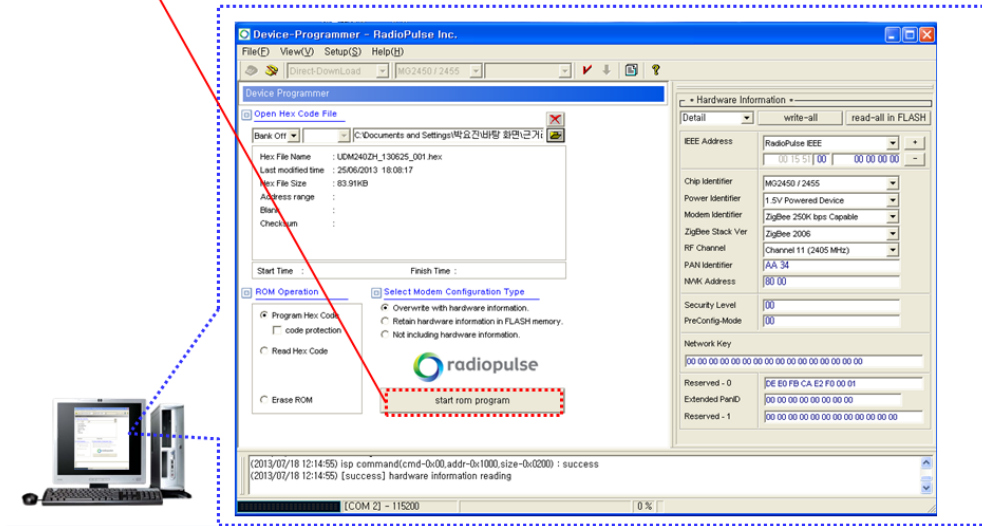

UDM-240ZH/240ZV Program

Check the status

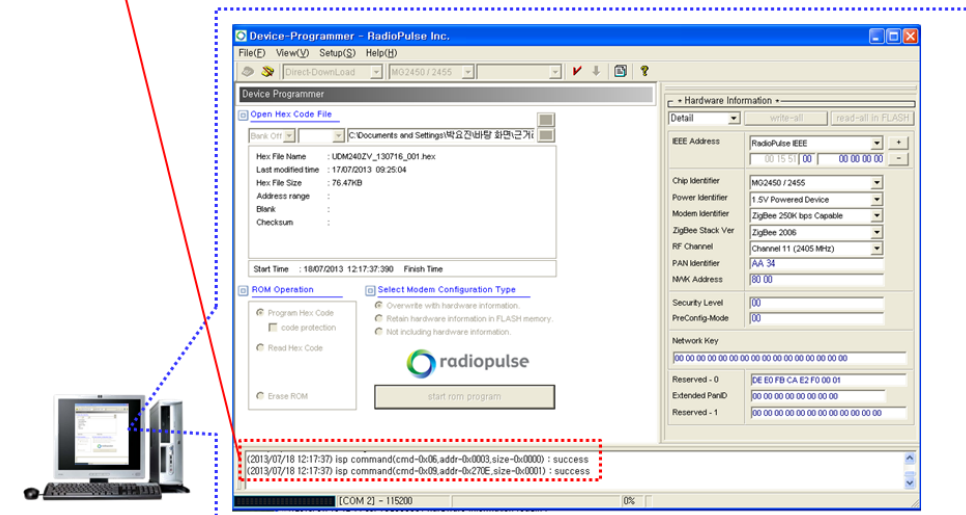

UDM-240ZV/ZBV



UDM-240ZH/240ZV Program

1. Click the "확인" button
2. Switch off the power supply to the product program
3. Disconnect the cable between the product and the program.

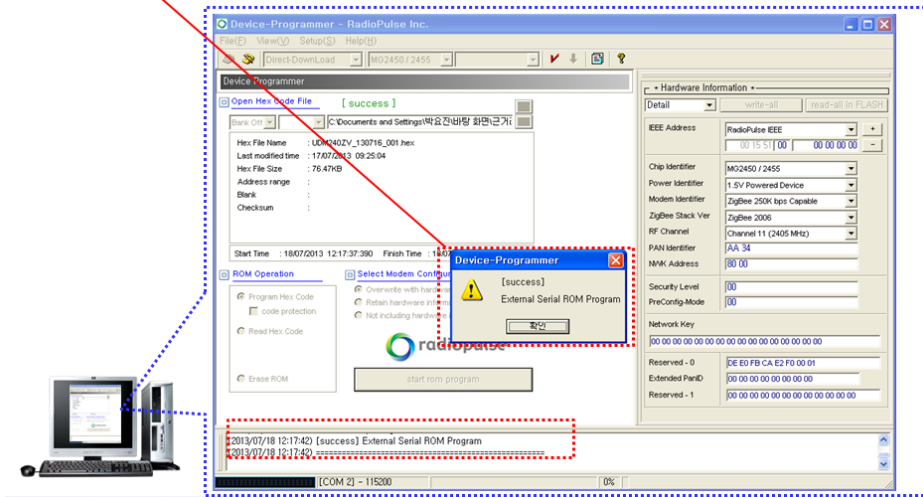

### Functional differences between the version of the program

Model Name	Features	The source file name	
UDM-240ZV	Vehicle ,Base, Receive automatic, Check busy	UDM240ZV_V1_1_송신무선처리.hex	New
	Vehicle , Base, Receive automatic, Check VOX	UDM240ZV_VOX_Level60_retry0.hex	신형
	Vehicle, Base, Check busy	UDM240ZV_노이즈개선_001.hex	New
UDM-240ZBV	Marine, Base, Receive automatic, Check busy	UDM240ZV_V1_1_송신무선처리.hex	New
	Marine, Base, Receive automatic, Check VOX	UDM240ZV_VOX_Level60_retry0.hex	New
UDM-240ZH	Vehicle, Main- PTT, Sub-PTT	UDM240ZH_V2_1car_retry_0.hex	New
	Vehicle, Main- PTT, Sub-PTT, Automatic connection	UDM240ZH_V2_1car_retry_1.hex	New
	Vehicle, Main- PTT, Alarm Coverage	UDM240ZH_1308-INT.hex	Old
	Vehicle, Main- INT, Alarm Coverage	UDM240ZH_1308-PTT.hex	Old
UDM-240ZBH	Marine, Scan, INT-Toggle	UDM240ZH_V2_1boat_retry_0_Toggle_INT.hex	New
	Marine, Scan, INT-Push	UDM240ZH_V2_1boat_Allscan_retry_0_NoINT.hex	New
	Marine, Automatic connection, Scan, INT-Toggle	UDM240ZH_V2_1boat_retry_1_Toggle_INT.hex	New
	Marine, Automatic connection, Scan, INT-Push	UDM240ZH_V2_1boat_Allscan_retry_1_NoINT.hex	New
PZ-400SZ	PZ-400SZ <u>Zigbee</u>	PZ-400SZ( <u>Zigbee</u> )-UDM240_130225_0.hex	Old
	PZ-400SZ	PZ_Rev_03_24_200NW400_Zigbee.hex	Old

**Please note that between the old and new version of the program, the UDM-240ZV[ZH] are not compatible each other.**



6 CIRCUIT DESCRIPTION

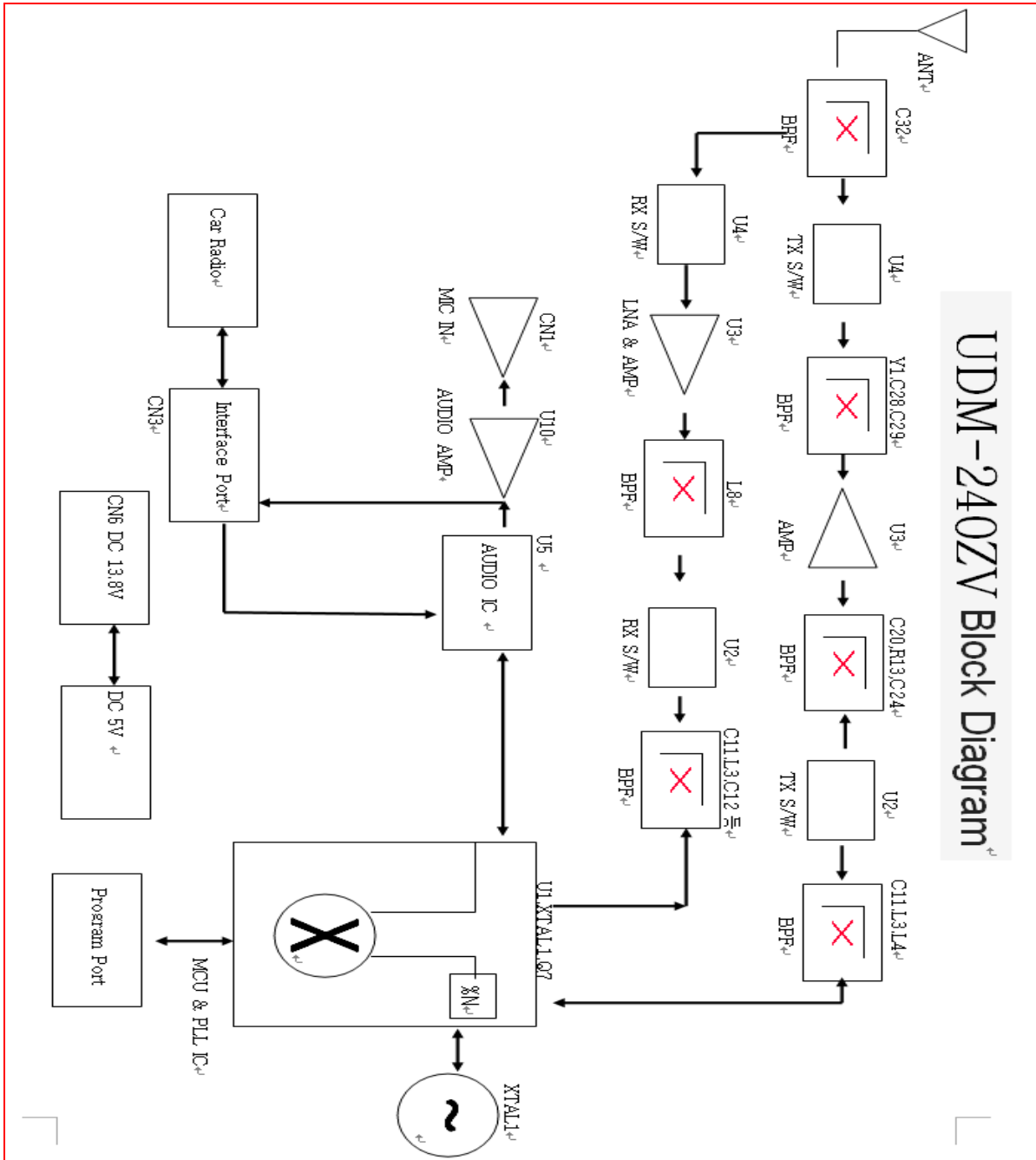

### Audio Amp

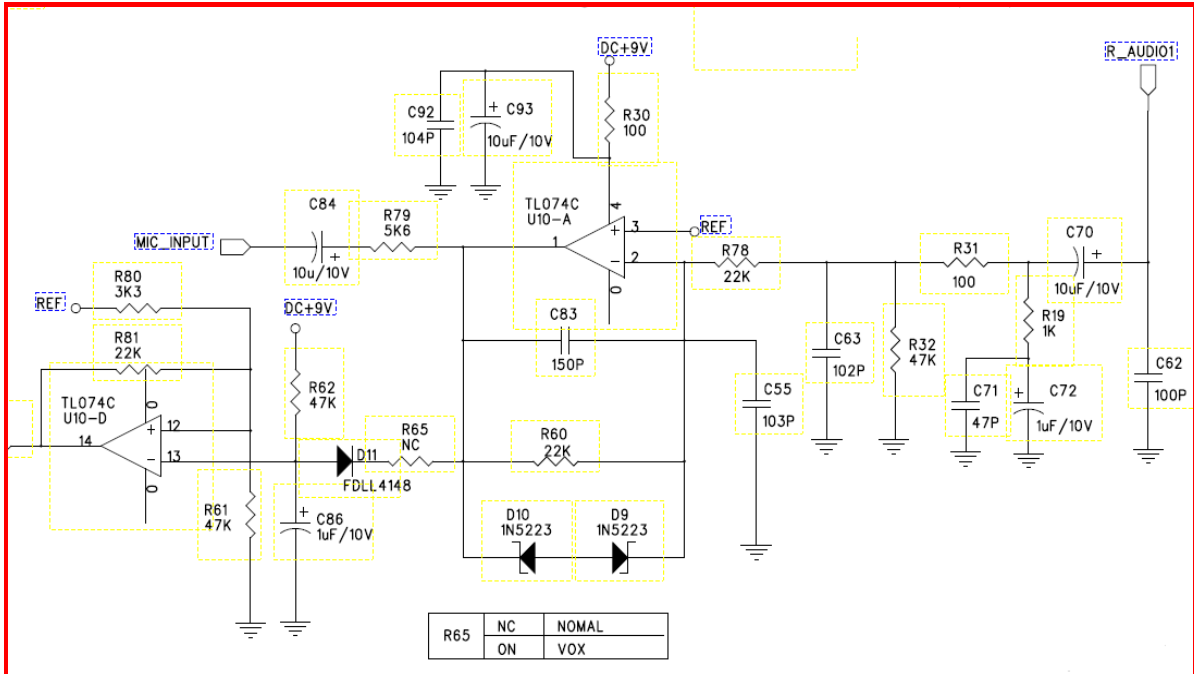

Code

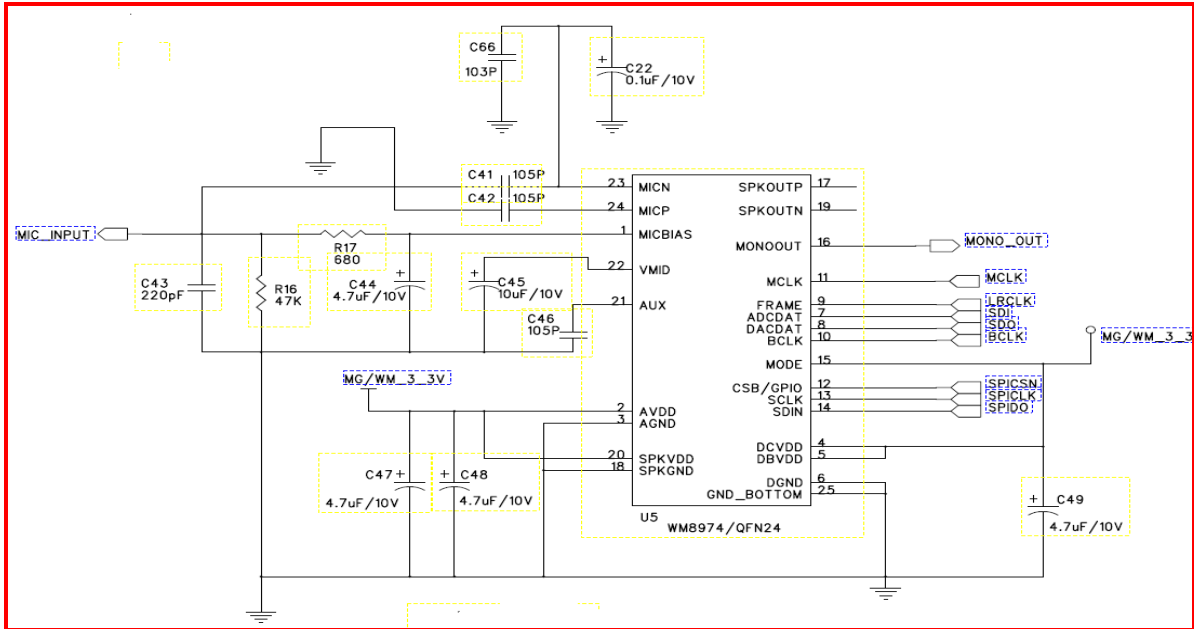

### Main Chip

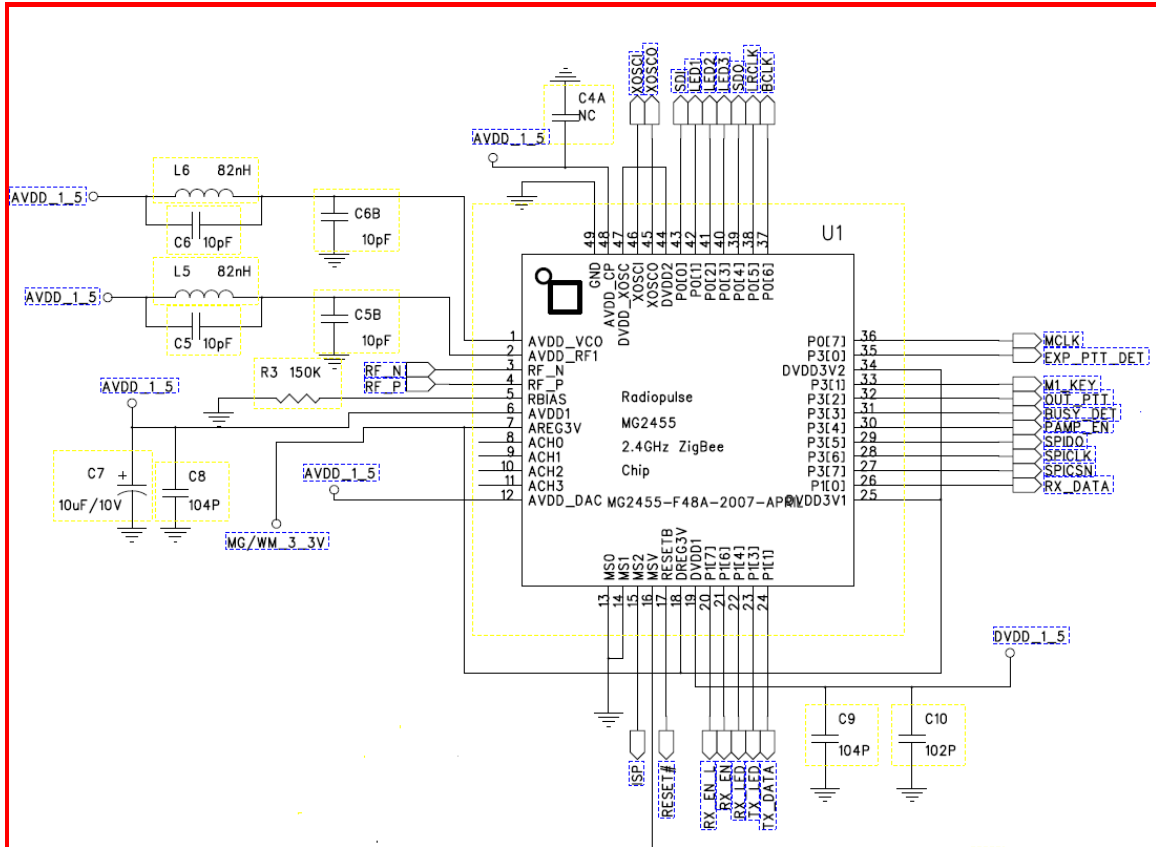

### MIC Amp

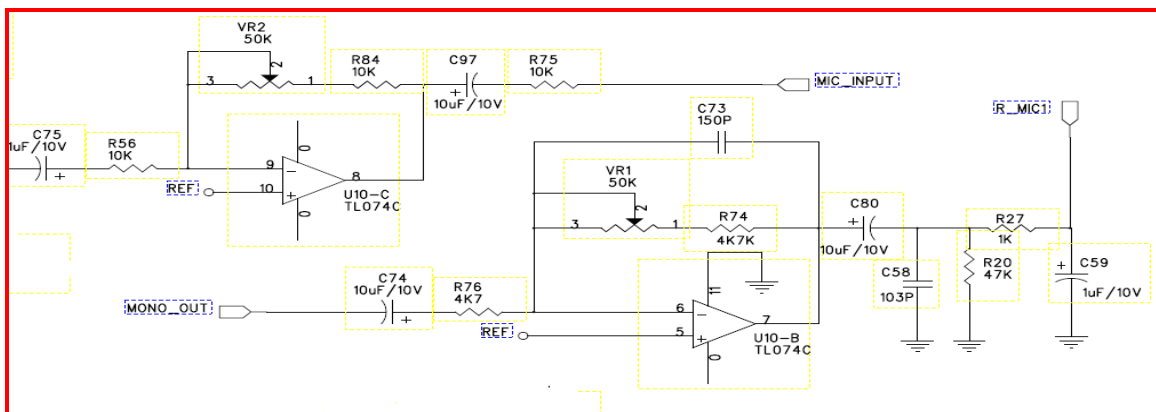

UDM-240ZV/ZBV

### Power Supply

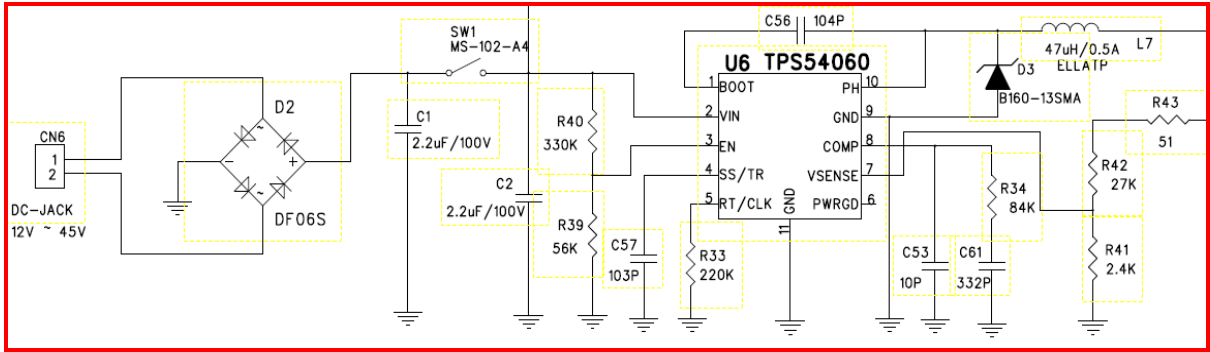

### Audio AMP

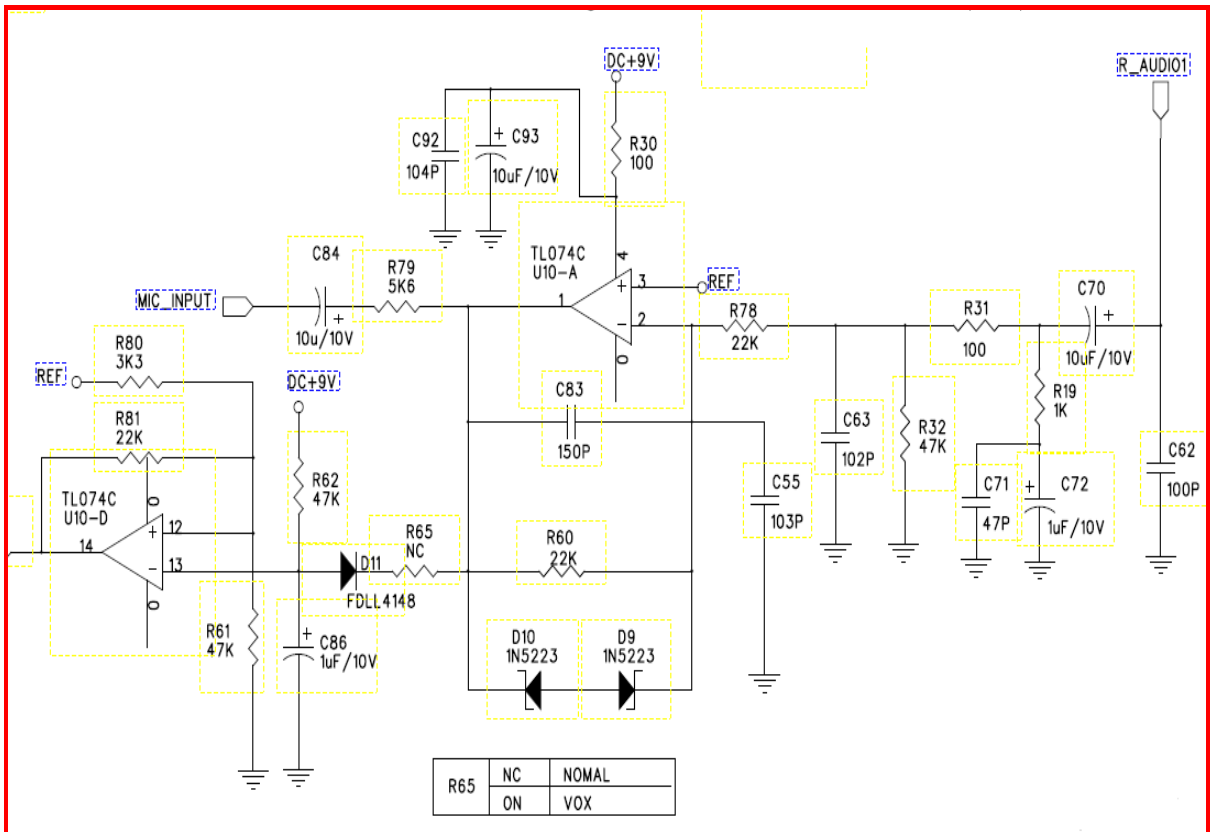

Parts Layout (top)

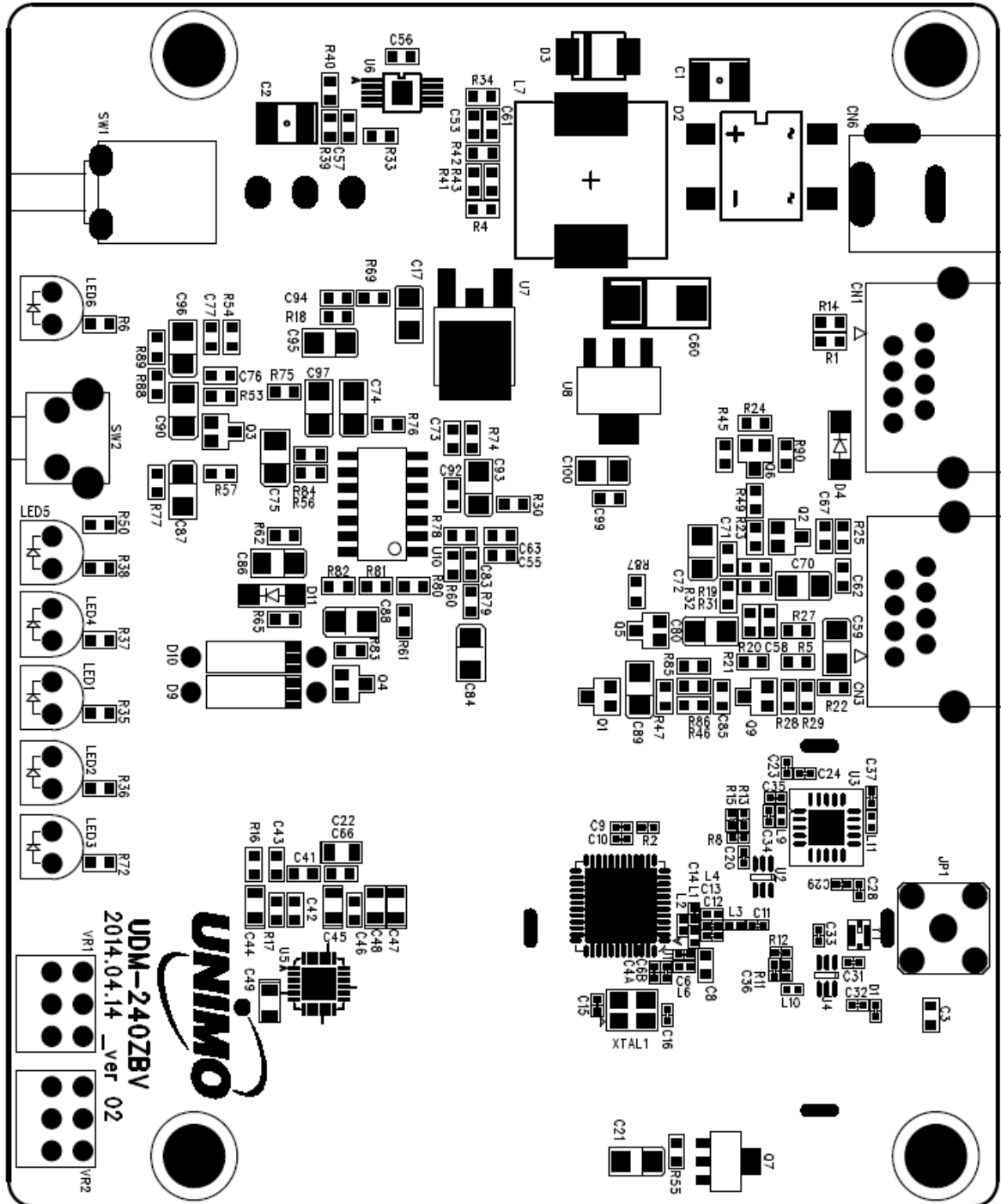

UDM-240ZV/ZBV

Parts Layout (bottom)

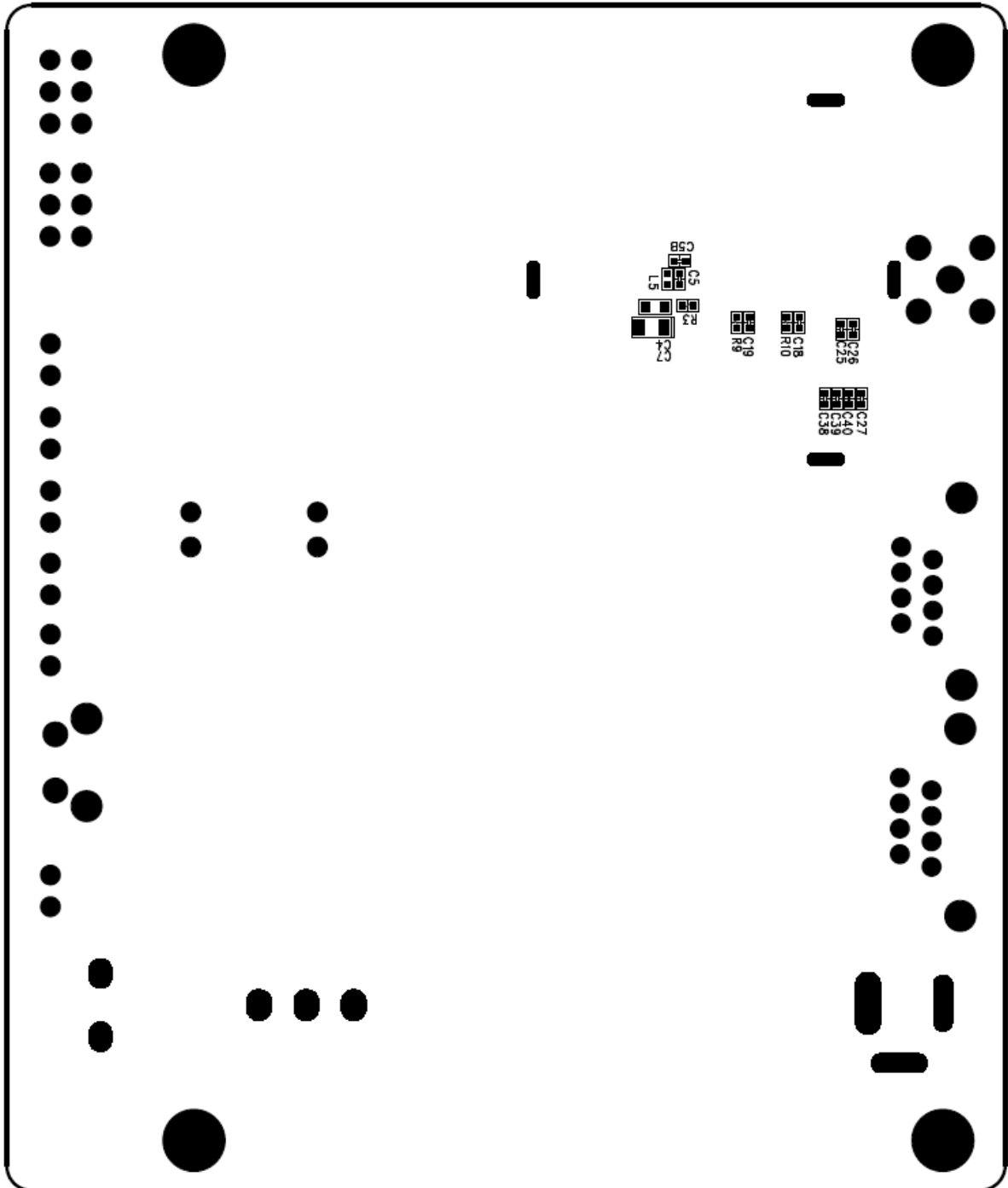

UDM-240ZV/ZBV

## 7 CIRCUIT DIAGRAM

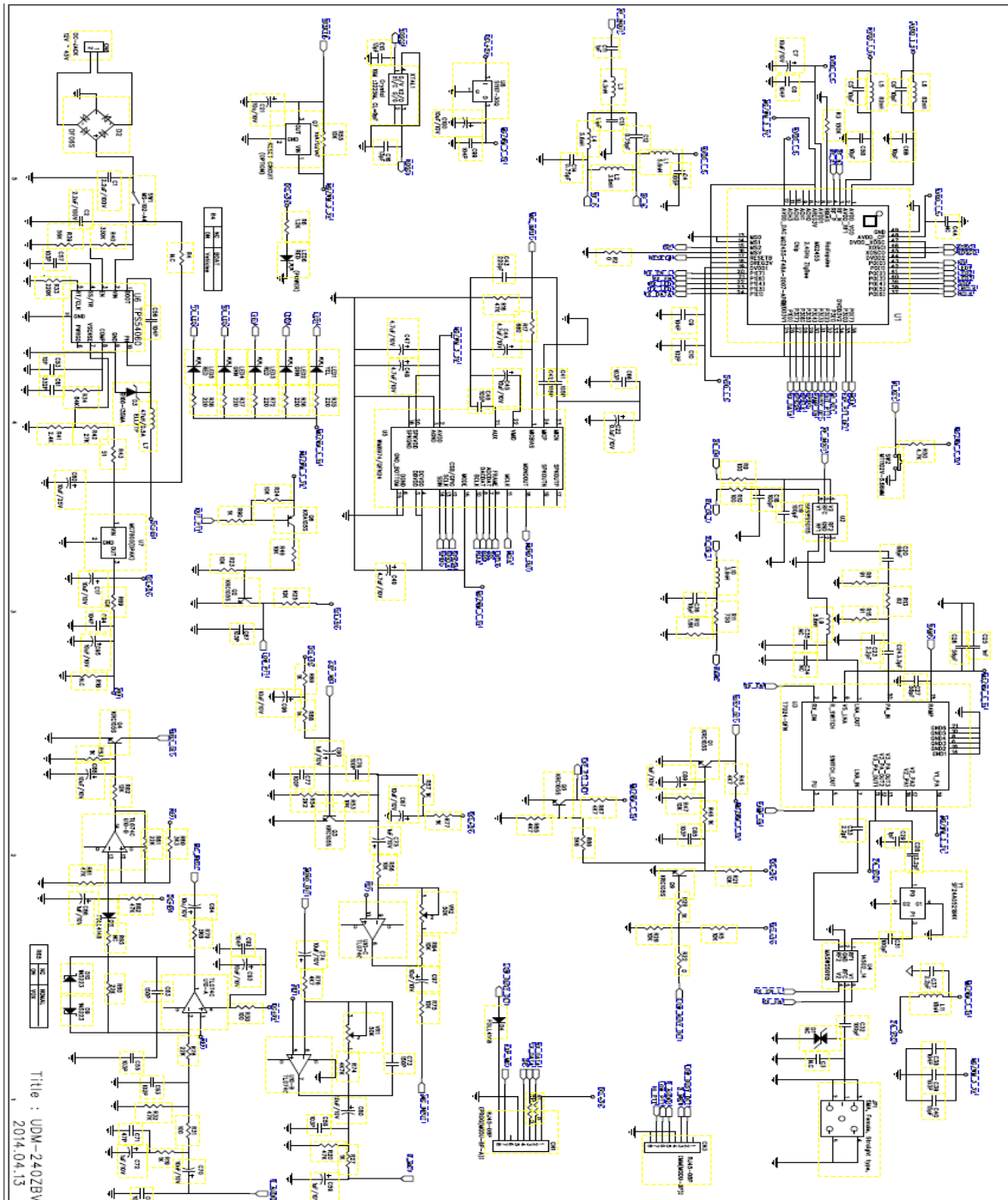

UDM-240ZV/ZBV



8 INSTALLATION

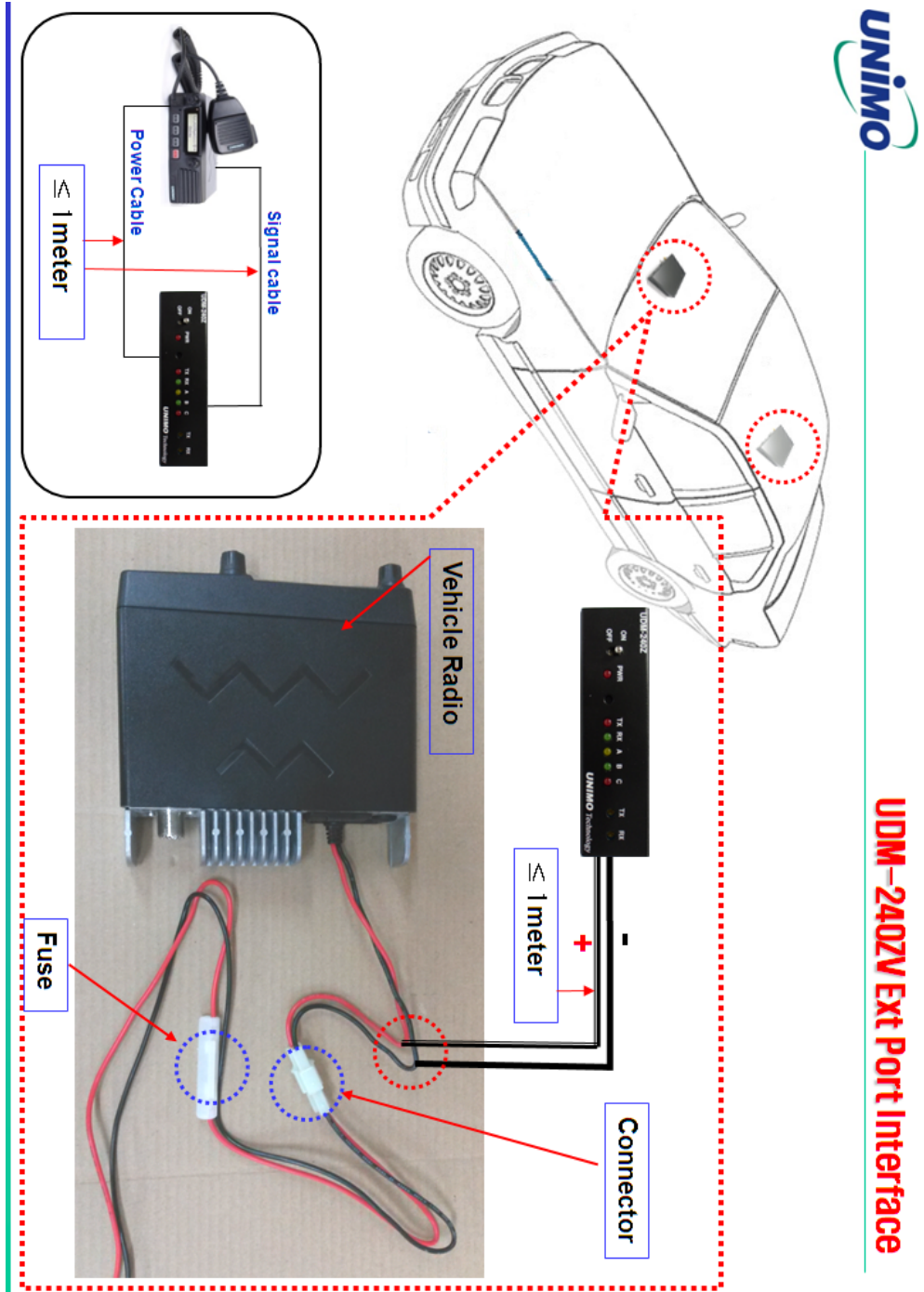

UDM-240ZV/ZBV

## 9 CONSIDERATIONS FOR INSTALLING

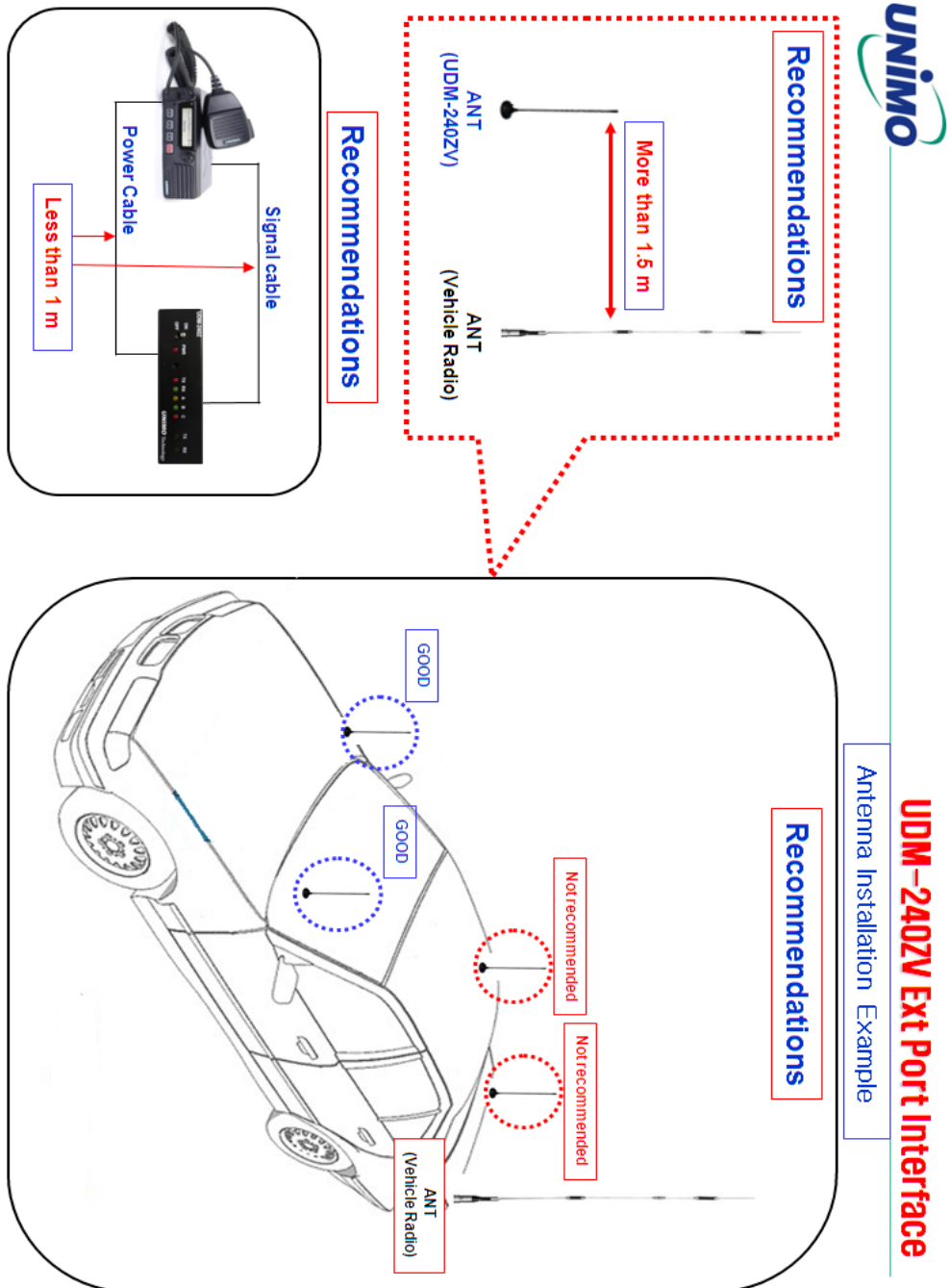

UDM-240ZV/ZBV

### UDM-240ZV Ext Port Interface

#### Currency distance

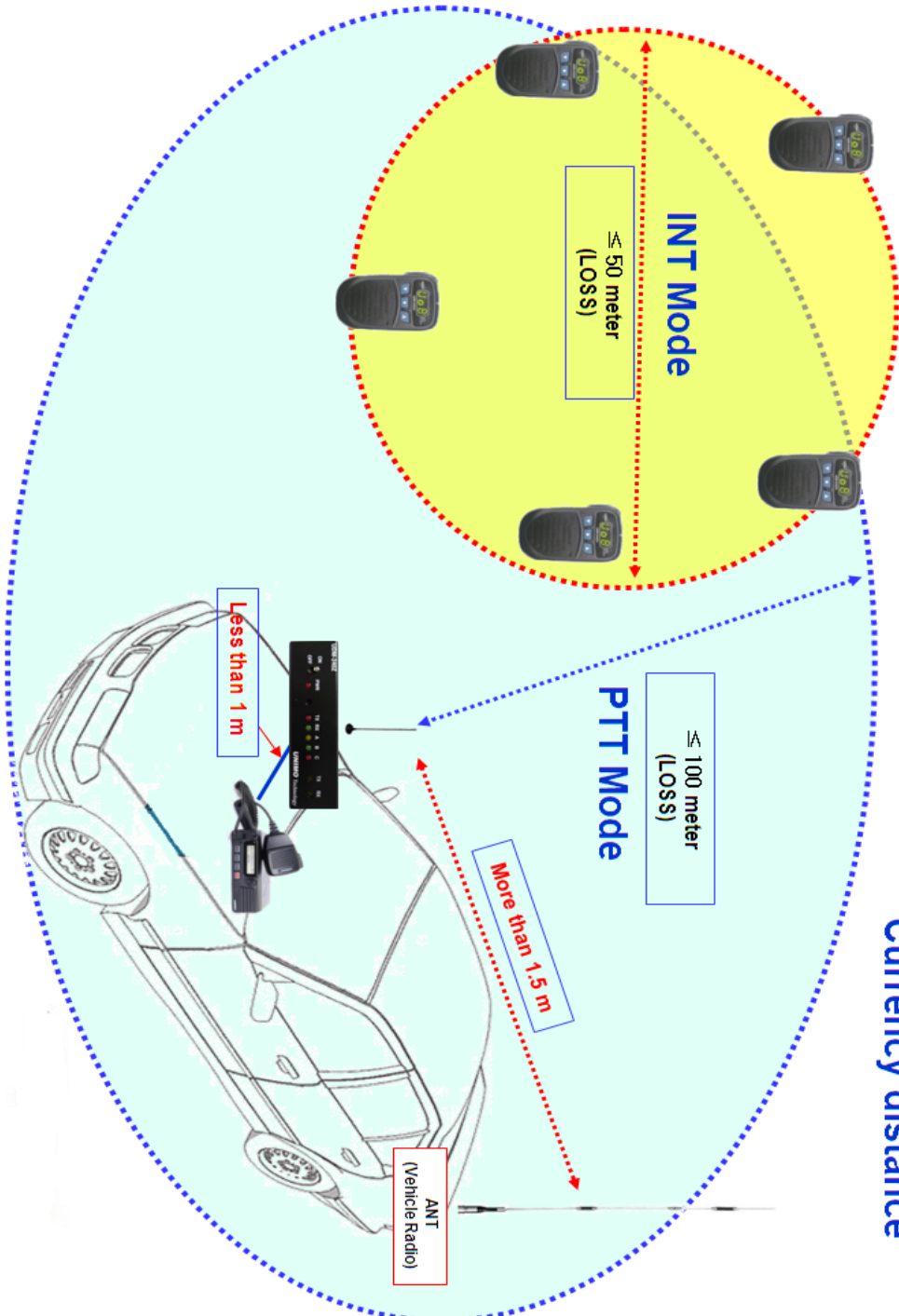

**FCC Information to User**

This equipment has been tested and found to comply with the limits for a Class B digital device, pursuant to Part 15 of the FCC Rules. These limits are designed to provide reasonable protection against harmful interference in a residential installation. This equipment generates, uses and can radiate radio frequency energy and, if not installed and used in accordance with the instructions, may cause harmful interference to radio communications. However, there is no guarantee that interference will not occur in a particular installation. If this equipment does cause harmful interference to radio or television reception, which can be determined by turning the equipment off and on, the user is encouraged to try to correct the interference by one of the following measures:

- Reorient or relocate the receiving antenna.
- Increase the separation between the equipment and receiver.
- Connect the equipment into an outlet on a circuit different from that to which the receiver is connected.
- Consult the dealer or an experienced radio/TV technician for help.

**Caution**

Modifications not expressly approved by the party responsible for compliance could void the user's authority to operate the equipment.

**FCC Compliance Information :** This device complies with Part 15 of the FCC Rules. Operation is subject to the following two conditions: (1) This device may not cause harmful interference, and (2) this device must accept any interference received, including interference that may cause undesired operation

**IMPORTANT NOTE:****FCC RF Radiation Exposure Statement:**

This equipment complies with FCC RF radiation exposure limits set forth for an uncontrolled environment. This equipment should be installed and operated with a minimum distance of 20 centimeters between the radiator and your body. This transmitter must not be co-located or operating in conjunction with any other antenna or transmitter.