



---

## Operation and Maintenance Manual

# DRU-200 SiriusXM<sup>®</sup> Dual Repeater

200W Dual Repeater Unit (DRU)

Unique Broadband Systems Ltd.  
400 Spinnaker Way • Vaughan • Ontario • Canada • L4K 5Y9  
Phone: (905) 669-8533 • Fax: (905) 669-8516  
[www.uniquesys.com](http://www.uniquesys.com)

---

**Document: SX03-10000-01-M01**  
**Revision: 01**  
**Date: July 2014**

**RESTRICTIONS ON USE, DUPLICATION OR DISCLOSURE  
OF PROPRIETARY INFORMATION**

This document contains information proprietary to Unique Broadband Systems Ltd., to its affiliates or to a third party to which Unique Broadband Systems Ltd. may have a legal obligation to protect such information from unauthorized disclosure, use or duplication. Any disclosure, use or duplication of this document or any of the information herein for other than the specific purpose for which it was disclosed by Unique Broadband Systems Ltd. is expressly prohibited, except as Unique Broadband Systems Ltd may otherwise agree in writing. Recipient by accepting this document agrees to the above stated conditional use of this document and this information disclosed herein.

Copyright © 2014, Unique Broadband System Ltd.

---

UBS  
Sirius XM DRU  
Dual  
Terrestrial Repeater

Model No: DRU-200  
Product Number: SX03-10000-02  
FCC ID: 2ACLT-DRU200

UBS  
Sirius XM DRU  
Dual  
Terrestrial Repeater

Model No: DRU-200  
Product Number: SX03-10000-03  
FCC ID: 2ACLT-DRU200

This device complies with part 15 of the FCC Rules.  
Operation is subject to the condition that this device  
does not cause harmful interference.

Note: This equipment has been tested and found to comply with the limits for a Class A digital device, pursuant to part 15 of the FCC Rules. These limits are designed to provide reasonable protection against harmful interference when the equipment is operated in a commercial environment. This equipment generates, uses, and can radiate radio frequency energy and, if not installed and used in accordance with the instruction manual, may cause harmful interference to radio communications. Operation of this equipment in a residential area is likely to cause harmful interference in which case the user will be required to correct the interference at his own expense.

**Caution:**

Changes or modifications not expressly approved by Unique Broadband Systems could void the user's authority to operate this equipment.

---

**This page has intentionally been left blank.**



**DRU-200**

**CONTENTS**

---

<b>SAFETY INSTRUCTIONS</b>	<b>1</b>
----------------------------	----------

---

<b>SYSTEM SPECIFICATIONS</b>	<b>2</b>
------------------------------	----------

---

<b>INSTALLATION</b>	<b>3</b>
---------------------	----------

---

<b>COMMISSIONING</b>	<b>4</b>
----------------------	----------

---

<b>OPERATION</b>	<b>5</b>
------------------	----------

---

<b>MAINTENANCE</b>	<b>6</b>
--------------------	----------

---

<b>CONTACT INFORMATION</b>	<b>7</b>
----------------------------	----------

---

**DRU-200**

**APPENDICES**

---

**REPEATER DRAWINGS  
AND DIAGRAMS**

**A**

---

## Chapter 1

# Safety Instructions





# Contents

<b>1</b>	<b>Safety Instructions .....</b>	<b>1-1</b>
1.1	Manual Overview.....	1-1
1.2	On-Site Safety.....	1-1
1.3	Safe Work Practices .....	1-2
1.4	Safety Notes.....	1-3
1.5	Graphic Symbols .....	1-4
1.6	Electrical Safety .....	1-5
1.6.1	Connection to the AC Power Supply .....	1-5
1.6.2	Installation.....	1-5
1.6.3	Commissioning and Maintenance .....	1-5
1.7	RF Safety.....	1-6
1.7.1	Non-ionizing Radiation .....	1-6
1.7.2	Rules for Operating the Repeater.....	1-6
1.8	Physical Safety.....	1-6
1.9	Static Electricity .....	1-7
1.9.1	Rules for Handling ESD Sensitive Modules.....	1-7
1.10	First Aid .....	1-7
1.10.1	Rescue Breathing .....	1-8
1.10.2	Burns.....	1-8

**This page has intentionally been left blank.**

## **1 Safety Instructions**

### **1.1 Manual Overview**

This manual contains a description of UBS' SiriusXM Digital Terrestrial Repeater DRU-200 (Combined and Independent configurations), as well as descriptions of the components/sub-assemblies which make up the repeater.

The manual also describes the steps required to install the repeater (and its components/sub-assemblies), put it into operation, operate/maintain it and service it. Where applicable, the repeater manual refers to the individual product manuals for several major assemblies. The Appendix includes repeater mechanical, functional and wiring drawings/diagrams.

### **1.2 On-Site Safety**

It is important that service technicians understand the hazards involved with working on broadcasting sites, are able to identify potential hazards and take appropriate action to minimize such hazards. This manual is intended as a general guide for trained and qualified personnel.

The installation, operation, maintenance and service of this equipment involves risks to both personnel and equipment, and must be performed only by qualified personnel exercising due care. Unique Broadband Systems Ltd. shall not be responsible for injury or damage resulting from improper procedures or from the use by improperly trained or inexperienced personnel performing such tasks.

During the installation and operation of this equipment, local building and electrical codes as well as fire protection standards must be observed. Always follow the relevant local or national safety rules and regulations.

### 1.3 Safe Work Practices



1. Workers shall not work in conditions that are unsanitary, hazardous or dangerous to their health or safety.
2. Workers shall wear appropriate personal protective equipment for the specific job or task.
3. Workers shall take all reasonable and necessary precautions to ensure their safety, the safety of their fellow workers and any person likely to be affected by their acts.
4. First aid kits and supplies shall be readily available on site at all times.
5. There shall be transportation readily available for an injured worker.
6. Any flammable material shall be handled and stored in a proper manner.
7. Workers in areas where there is a possible danger of head injury from the impact of falling objects, or from electrical shocks or burns shall wear proper head protection such as a hard hat.
8. Hard hats shall be worn at all times while an overhead hazard exists.
9. When machines or operations present a possible eye injury, proper eye protection shall be worn.
10. Safety toe work boots shall be worn where there is a danger of foot injury.
11. Signs and signals shall be used to alert people of potential dangers.

## 1.4 Safety Notes

Please review the following notes and familiarize yourself with the operation and servicing procedures before working on the repeater.

**Read All Safety Instructions** – All of the safety instructions should be read and understood before operating the repeater.

**Heed all Notes, Warnings, and Cautions** – All of the notes, warnings, and cautions listed in this safety section and throughout the manual must be followed.

**Follow Installation and Operating Instructions** – All of the installation and operating instructions for the repeater should be followed.

**Retain Manuals** – The manuals for the repeater should be retained at the site for future reference.

**Repeater Ratings** - The repeater ratings are provided in the text of this manual along with voltage and current values for the equipment.

**Hazardous Accessibility** – UBS has made attempts to provide appropriate connectors, wiring and shields to minimize hazardous accessibility.

**Protective Earthing Terminal** – A main protective earthing terminal is provided for equipment required to have protective earthing.

**Single Point Breaker or Disconnect** - The customer should provide a single point breaker or disconnect at the breaker box for the main AC input connection to the repeater.

**Circuit Breakers and Wiring** – All circuit breakers and wire are UL and CE certified and are rated for maximum operating conditions.

**Ventilation** – Openings in the cabinet are provided for ventilation. To ensure the reliable operation of the repeater and to protect the unit from overheating, these openings must not be blocked.








**Servicing** – Do not attempt to service the repeater yourself until becoming familiar with the equipment. If in doubt, refer all servicing questions to qualified UBS service personnel.

**Cleaning** – Unplug or otherwise disconnect all power from the equipment before cleaning. Do not use liquid or aerosol cleaners. Use only a damp cloth for cleaning.

**Replacement Parts** – When replacement parts are used, be sure that the parts have the same functional and performance characteristics as the original part. Unauthorized substitutions may result in fire, electric shock, or other hazards. Please contact UBS if you have any questions regarding service or replacement parts.

1.5 Graphic Symbols

Specific warning and caution statements, where applicable, are found throughout this manual.

Symbol	Meaning	Explanation
	High Voltage	Danger - High voltage and/or risk of electric shock.
	Warning	Warning - To prevent damage to equipment or personal injury, the operator must refer to all operating instructions in the manual.
	Electrostatic Discharges	Caution - Improper handling of equipment may result in damage to equipment from electrostatic discharges (ESD).
	Non-ionizing Radiation	Caution - Exposure to radio frequencies may result in person injury.
	Tipping Hazard	Caution - Over tipping the repeater may cause it to fall over, resulting in personal injury or loss of life.
	Lifting Hazard	Caution - Lifting heavy objects may result in personal injury.
	Hot Surface Hazard	Caution - Touching hot surfaces may result in burns. Allow surface to cool before servicing equipment.

## 1.6 Electrical Safety

### 1.6.1 Connection to the AC Power Supply


Electrical connections between the repeater and the building/site electrical service panel must comply with the following conditions:

- A properly rated circuit breaker must be installed in the building/site electrical service panel.
- A properly rated power cable must be used to connect the repeater to the building/site electrical service panel.
- A readily accessible disconnect device shall be installed between the repeater PDU and building/site electrical service panel.
- The repeater can be secured against unintentional power-on.

### 1.6.2 Installation

- Ensure that all repeater PDU circuit breakers and sub-assembly power switches are switched off during the installation.
- Ensure that the main AC power cable to the repeater PDU is the last cable connected to the repeater when installing repeater cables.

### 1.6.3 Commissioning and Maintenance


	Never work on live parts unless specifically required and only if special safety precautions are followed.
---	--

Carefully observe the specific procedures for commissioning and maintenance where AC or DC power is present and observe the following rules.


- Remove rings, watches, and any other metallic jewelry. Short circuits in low-voltage, low-impedance DC circuits can cause severe arcing, which may result in burns or eye injury. Exercise caution to avoid shorting power input terminals.
- Ensure that the repeater's main breaker (or disconnect device) is turned off and a **"DANGER-DO NOT TURN ON - Personnel Working"** sign is hung on the breaker prior to working on the repeater's internal parts.
- Secure the repeater against unintentional power-on.
- Verify that the repeater is isolated from any power.
- Ensure that all repeater PDU circuit breakers are switched off prior to working on internal parts.

## 1.7 RF Safety

### 1.7.1 Non-ionizing Radiation


	<p>The American National Standards Institute (ANSI) has determined that it may be harmful for the human body to be exposed to Radio Frequencies in the range of 3KHz to 300GHz. In that range, people are not allowed to be exposed to RF power levels greater than 1mW/cm<sup>2</sup> for longer than 5 minutes.</p>
---	---

### 1.7.2 Rules for Operating the Repeater

	<p>Opening RF lines during operation may cause electric arcs that can cause burns and eye injuries.</p>
---	---

- Ensure that the repeater RF output ports are connected to properly rated antennas or test (dummy) loads before the repeater is powered on.
- Never turn on RF power if an RF line is open.
- Never undo RF lines during repeater operation.
- Never open modules during repeater operation.


## 1.8 Physical Safety

	<p>Over tipping the repeater may cause it to fall over, resulting in personal injury or loss of life.</p>
---	---

- The repeater will be secured to the building/pad before operation.
- Installation crew members must wear hard hats and steel toe boots/shoes during the installation.
- A minimum of two technicians is required for any lifting and/or positioning of the repeater cabinet.



## 1.9 Static Electricity

	<p>This product contains ESD (Electrostatic Discharge) sensitive devices. Careless handling during repair can weaken, damage or destroy the devices.</p>
---	--


Items such as clothing, paper/cardboard and plastics are the most common sources of electrostatic discharge. Please ensure that cellophane, plastics, masking tapes and white foam do not come into contact with ESD sensitive modules or their packaging.

### 1.9.1 Rules for Handling ESD Sensitive Modules

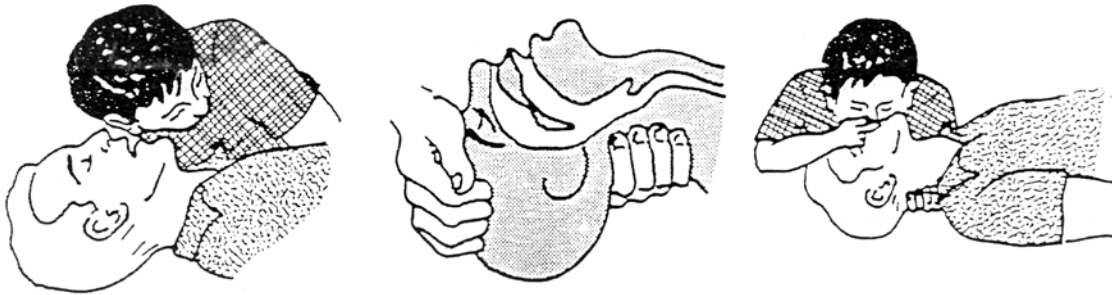
When repairing a module, proper ESD procedures should be followed to minimize the risk of damaging the module.

- All modules should be handled as ESD sensitive devices.
- Failed modules should be handled with the same care as good modules.
- Modules should be stored, packed, or shipped in antistatic bags or containers.
- Do not handle modules by touching the electronic components and/or PCB.
- Either wrist or heel ground straps should be worn prior to and during handling of modules containing ESD sensitive devices.
- Heel straps are only effective while standing on conductive or static dissipative surfaces.
- Surfaces (with resistance to ground in excess of 100 Meg-ohms), such as ordinary tile, should be covered with properly grounded static dissipative runners or waxed with a static dissipative wax.
- Use only ESD rated cleaning devices to clean modules.

## 1.10 First Aid

	<p>Personnel engaged in the installation, operation, or maintenance of the repeater are urged to become familiar with the following rules both in theory and practice. It is the duty of all operating personnel to be prepared to give adequate Emergency First Aid and thereby prevent avoidable loss of life.</p>
---	--

**1.10.1 Rescue Breathing**



<p>1. Find out if the person is breathing.</p> <p>You must find out if the person has stopped breathing. If you think he is not breathing, place him flat on his back. Put your ear close to his mouth and look at his chest. If he is breathing you can feel the air on your cheek. You can see his chest move up and down. If you do not feel the air or see the chest move, he is not breathing.</p>	<p>2. If he is not breathing, open the airway by tilting his head backwards.</p> <p>Lift up his neck with one hand and push down on his forehead with the other. This opens the airway. Sometimes doing this will let the person breathe again by himself.</p>	<p>3. If he is still not breathing, begin rescue breathing.</p> <ul style="list-style-type: none"> <li>• Keep his head tilted backward. Pinch nose shut.</li> <li>• Put your mouth tightly over his mouth.</li> <li>• Blow into his mouth once every five seconds</li> <li>• <b>DO NOT STOP</b> rescue breathing until help arrives.</li> </ul> <p>LOOSEN CLOTHING - KEEP WARM</p> <p>Do this when the victim is breathing by himself or help is available. Keep him as quiet as possible and from becoming chilled. Otherwise treat him for shock.</p>
---	--	---

**1.10.2 Burns**

**Skin Reddened:** Apply ice cold water to the burned area to prevent the burn from going deeper into skin tissue. Cover the area with a clean sheet or cloth to keep away air. Consult a physician.

**Skin Blistered or Flesh Charred:** Apply ice cold water to the burned area to prevent the burn from going deeper into skin tissue.

**Extensive Burn – Skin Broken:** Cover the area with a clean sheet or cloth to keep away air. Treat the victim for shock and take to hospital.

## Chapter 2

# System Specifications



## Contents

<b>2 System Specifications .....</b>	<b>2-1</b>
2.1 External Input Signal Interfaces .....	2-1
2.2 External Output Signal Interfaces .....	2-2
2.3 High Band RF Output .....	2-2
2.4 Low Band Main RF Output .....	2-3
2.5 Low Band Diversity RF Output .....	2-4
2.6 Power Supply .....	2-5
2.7 Mechanical .....	2-5
2.8 Environmental .....	2-5

**This page has intentionally been left blank.**

## 2 System Specifications

### 2.1 External Input Signal Interfaces

S-Band Antenna	
Connector Name	S-SAT
Connector Type	N (female)
Connector Impedance	50 $\Omega$

Ku-Band Antenna	
Connector Name	V SAT
Connector Type	F (female)
Connector Impedance	75 $\Omega$

GPS Antenna	
Connector Name	GPS
Connector Type	N (female)
Connector Impedance	50 $\Omega$

Test Antenna	
Connector Name	ANT
Connector Type	SMA (female)
Connector Impedance	50 $\Omega$

PSTN Phone Line	
Cable Gland Name	TEL
Connector Type	Screw down terminals
Dial-up Modem Manufacturer	Multitech Systems
Model Number	MT5634IND
ACTA Registration Number	AU7USA-25814-M5-E
Ringer Equivalence Number	0.3B

## 2.2 External Output Signal Interfaces

Combined RF Output Port	
Connector Name	Output 1
Connector Type	7/8" EIA Flange
Connector Impedance	50 Ω

Independent RF Output Port	
Connector Name	Output 2
Connector Type	7/8" EIA Flange
Connector Impedance	50 Ω

## 2.3 High Band RF Output

High Band RF Output	
Standard	XM Satellite Radio
Output Connector	Output 1
Output VSWR	< 1.3:1
Centre Frequency	2338.755 MHz
Bandwidth	5.060 MHz
Output Power Level	43 dBm to 53 dBm (20 W to 200 W)
Output Power Level Stability (with ALC engaged)	± 0.2 dB
Spectral Re-growth	> 24 dBc
In-band Carrier to Interference	> 21 dBc
Peak-to-Average Ratio (@ 0.1% CCDF)	> 7.0, < 13.0
Gain Flatness	≤ +0.75 dB
In-band/Out-of-Channel Emissions	> 30 dBc: @ 2335.255 MHz, @ 2342.255 MHz  > 46 dBc: @ 2333.515 MHz, @ 2343.995 MHz
Out-of-Band Emissions	< -90 dB Watts/MHz (< 2320.0 MHz, > 2345.0 MHz)  < -80 dB Watts/MHz (2332.5 - 2345.0 MHz)



## 2.4 Low Band Main RF Output

Low Band RF Output	
Standard	Sirius Satellite Radio
Output Connector	Combined DRU: Output 2 Independent DRU: Output 1
Output VSWR	< 1.3:1
Centre Frequency	2326.250 MHz
Bandwidth	4.012 MHz
Output Power Level	43 dBm to 53 dBm (20 W to 200 W)
Output Power Level Stability (with ALC engaged)	± 0.2 dB
Spectral Re-growth	> 27 dBc
In-band Carrier to Interference	> 24 dBc
Peak-to-Average Ratio (@ 0.1% CCDF)	> 7.0, < 13.0
Gain Flatness	≤ +0.75 dB
In-band/Out-of-Channel Emissions	> 35 dBc: @ 2322.138 MHz  > 35 dBc: @ 2330.362 MHz
Out-of-Band Emissions	< -90 dB Watts/MHz (< 2320.0 MHz, > 2345.0 MHz)  < -80 dB Watts/MHz (2332.5 - 2345.0 MHz)

## 2.5 Low Band Diversity RF Output

Low Band Diversity RF Output	
Standard	Sirius Satellite Radio
Output Connector	Combined DRU: Output 1 Independent DRU: Output 2
Output VSWR	< 1.3:1
Centre Frequency	2326.256040 MHz
Bandwidth	80 kHz
Output Power Level	16 – 26 dBm (40 mW to 400 mW)
Output Power Level Stability (with ALC engaged)	N/A
Spectral Re-growth	> 30 dBc
In-band Carrier to Interference	N/A
Peak-to-Average Ratio (@ 0.1% CCDF)	> 3.0, < 5.0
Gain Flatness	N/A
In-band/Out-of-Channel Emissions	> 45 dBc @ 2322.138 MHz  > 45 dBc @ 2330.362 MHz
Out-of-Band Emissions	< -97 dB Watts/MHz (< 2320.0 MHz, > 2345.0 MHz)  < -87 dB Watts/MHz (2332.5 - 2345.0 MHz)

## 2.6 Power Supply

Power Supply	
Voltage	190 – 264 VAC (208 VAC nominal), Single Phase
Frequency	47 to 63 Hz
Power Consumption	max. 6.1 kVA

## 2.7 Mechanical

Mechanical	
Width	42.80 in. (108.71 cm)
Depth	43.80 in. (111.25 cm)
Height	82.50 in. (209.55 cm)
Weight (unpacked)	825 lbs. (374 kg)

## 2.8 Environmental

Environmental	
Ambient Operating Temperature	-4°F to +131°F (-20°C to +55°C)
Ambient Storage Temperature	-22°F to +167°F (-30°C to +75°C)
Operating Humidity	5% to 95%, non-condensing
Storage Humidity	5% to 99%, non-condensing
Altitude	max. 5500 ft. (1676 m)
Electronics Compartment Cooling	Air-to-Air Heat Exchanger
Electronics Compartment Inside Temperature	14°F to +149°F (-10°C to +65°C)
Electronics Compartment Heat Dissipation	max. 600 W
HPA Compartment Cooling	Forced Air, 1400 CFM
HPA Compartment Inside Temperature	-4°F to +131°F (-20°C to +55°C)
HPA Compartment Heat Dissipation	max. 2920 W

**This page has intentionally been left blank.**

## Chapter 3

# Installation



## Contents

<b>3</b>	<b>Installation .....</b>	<b>3-1</b>
3.1	Introduction.....	3-1
3.2	Components/Sub-Assemblies Installed at the Factory.....	3-1
3.3	Components/Sub-Assemblies Installed On-Site.....	3-3
3.4	Required Tools .....	3-4
3.5	Installation Overview.....	3-5
3.6	Repeater Setup .....	3-6
3.6.1	Moving the Repeater Cabinet .....	3-6
3.6.2	Installation Surface .....	3-7
3.6.3	Repeater Cabinet Positioning.....	3-7
3.6.4	Unpacking.....	3-9
3.7	Electronics Compartment Components.....	3-9
3.7.1	BMS 12 VDC Rectifier Module.....	3-12
3.7.2	High Band Exciter (HBE).....	3-13
3.7.3	Low Band Exciter (LBE).....	3-14
3.7.4	Terrestrial Repeater Monitoring System (TRMS).....	3-15
3.7.5	Dial-up Modem .....	3-15
3.8	HPA Compartment Components .....	3-15
3.8.1	Combined DRU Pre-installation.....	3-18
3.8.2	Independent DRU Pre-installation .....	3-20
3.8.3	DR Filter Box .....	3-21
3.8.4	High Power Amplifier (HPA) .....	3-24
3.8.5	Finalize DR Filter Box and HPA Installation.....	3-27
3.8.6	HPA PSU 30 VDC Rectifier Module.....	3-27
3.9	Internal Wire/Cable Connections .....	3-29
3.9.1	Ground and AC Connections.....	3-30
3.9.2	High Band Exciter (HBE).....	3-31
3.9.3	Low Band Exciter (LBE).....	3-32
3.9.4	Terrestrial Repeater Monitoring System (TRMS).....	3-34
3.9.5	Dial-up Modem .....	3-35
3.10	External Input Signal Interfaces .....	3-36
3.10.1	S-Band Antenna.....	3-37
3.10.2	Ku-Band Antenna .....	3-37
3.10.3	GPS Antenna .....	3-37
3.11	Communications Interfaces .....	3-38
3.11.1	PSTN Phone Line.....	3-38
3.12	Shelter/Room Alarm Connections .....	3-40
3.13	RF Output Interfaces.....	3-42
3.14	AC Power.....	3-44
3.14.1	General Requirements.....	3-44
3.14.2	Repeater Cabinet Ground Connection .....	3-44
3.14.3	Repeater Cabinet AC Power Connection .....	3-46

**This page has intentionally been left blank.**



### 3 Installation

#### 3.1 Introduction

This section describes the installation procedures for the DRU-200, which is to be installed in a restricted access location.

#### 3.2 Components/Sub-Assemblies Installed at the Factory

The following components/sub-assemblies are installed in a Combined DRU cabinet prior to shipping.

**Table 3-1 Combined DRU Components/Sub-Assemblies Installed at the Factory**

Name	Part Number	Quantity
PDU	SX03-10300-01	1
Low Noise Amplifier (LNA)	SX03-50100-01	1
Dual Band Pass Filter (DBPF)	SX03-50200-01	1
BMS Mounting Shelf w/Controller	SX03-50300-01	1
BMS 12 VDC Battery	SX03-50330-01	1
Air-to-Air Heat Exchanger/Heater	SX03-50400-01	1
Break Out Board	SX03-92020-01	1
7/8" Short U-link/Coupler	SX03-10402-01	2
Fan (Blower) Box	SX03-50500-01	1
7/8" Combined Output Coupler/RF Detector	SX03-51430-01	1
HPA PSU Mounting Shelf	SX03-51710-01	1

**NOTE:** A number of other components, which were installed in the cabinet prior to shipping, are not listed in Table 3-1. They include:

- Surge protectors
- Connectors, adapters and flanges
- Mounting brackets and panels
- Ground, AC, DC and communications wires
- RF cables

The following components/sub-assemblies are installed in an Independent DRU cabinet prior to shipping.

**Table 3-2 Independent DRU Components/Sub-Assemblies Installed at the Factory**

Name	Part Number	Quantity
PDU	SX03-10300-01	1
Low Noise Amplifier (LNA)	SX03-50100-01	1
Dual Band Pass Filter (DBPF)	SX03-50200-01	1
BMS Mounting Shelf w/Controller	SX03-50300-01	1
BMS 12 VDC Battery	SX03-50330-01	1
Air-to-Air Heat Exchanger/Heater	SX03-50400-01	1
Break Out Board	SX03-92020-01	1
7/8" Short U-link/Coupler	SX03-10402-01	1
7/8" Long U-link/Coupler	SX03-10403-01	1
Fan (Blower) Box	SX03-50500-01	1
7/8" Combined Output Coupler/RF Detector	SX03-51430-01	1
7/8" Independent Output Coupler/RF Detector	SX03-51450-01	1
HPA PSU Mounting Shelf	SX03-51710-01	1

**NOTE:** A number of other components, which were installed in the cabinet prior to shipping, are not listed in [Table 3-2](#). They include:

- Surge suppressors
- Connectors, adapters and flanges
- Mounting brackets and panels
- Ground, AC, DC and communications wires
- RF cables

### 3.3 Components/Sub-Assemblies Installed On-Site

The following components/sub-assemblies must be installed in a Combined DRU on-site, after delivery.

**Table 3-3 Combined DRU Components/Sub-Assemblies Installed On-site**

Name	Part Number	Quantity
BMS 12 VDC Rectifier Module	SX03-50320-01	2
LBE	N/A	1
HBE	N/A	1
TRMS	N/A	1
Dial-up Modem	N/A	1 (site dependent)
DR Filter Box	SX03-10700-02	1
High Power Amplifier (HPA)	SX03-40000-01	2
HPA PSU 30 VDC Rectifier Module	SX03-51720-01	2

The following components/sub-assemblies must be installed in an Independent DRU on-site, after delivery.

**Table 3-4 Independent DRU Components/Sub-Assemblies Installed On-site**

Name	Part Number	Quantity
BMS 12 VDC Rectifier Module	SX03-50320-01	2
LBE	N/A	1
HBE	N/A	1
TRMS	N/A	1
Dial-up Modem	N/A	1 (site dependent)
DR Filter Box	SX03-10700-03	1
High Power Amplifier (HPA)	SX03-40000-01	2
HPA PSU 30 VDC Rectifier Module	SX03-51720-01	2

### 3.4 Required Tools

The following tools will be needed to install the repeater:

**Table 3-5 Required Tools**

Tool	Type	Size
Screwdriver	Phillips	#3
Screwdriver	Phillips	#2
Screwdriver	Slotted	1/4"
Screwdriver	Slotted	3/32"
Hex Driver		9/64"
Open End Wrench		1/2"
Open End Wrench		7/16"
Open End Wrench		11/32"
Open End Wrench		5/16"
Torque Wrench		5/16"
Wire Stripper		

### 3.5 Installation Overview

The repeater can be installed by following the basic sequence below:

- Repeater set-up
  - Check the installation surface structure, flatness and suitability.
  - Position the repeater cabinet according to site drawings.
  - Unpack the components (assemblies).
- Electronics compartment components (assemblies)
  - Install the BMS 12 VDC rectifier module in the BMS mounting shelf.
  - Mount the HBE in the electronics compartment.
  - Mount the LBE in the electronics compartment.
  - Mount the TRMS in the electronics compartment.
  - Mount the dial-up modem in the electronics compartment (where applicable).
- HPA compartment components (assemblies).
  - Install the DR filter box in the HPA compartment.
  - Install the HPA's in the HPA compartment.
  - Install the HPA 30 VDC rectifier modules in the HPA PSU mounting shelf.
- Internal wire/cable connections
  - Connect the ground, communications, RF and power wires/cables to the HBE.
  - Connect the ground, communications, RF and power wires/cables to the LBE.
  - Connect the ground, communications, RF and power wire/cables to the TRMS.
  - Connect the ground, communications and power wire/cables to the dial-up modem (where applicable).
- External input signal interfaces
  - Connect the cable from the S-Band antenna to the S-SAT surge protector.
  - Connect the cable from the Ku-Band VSAT antenna to the V SAT surge protector.
  - Connect the cable from the GPS antenna to the GPS surge protector.
- Communications interface
  - Connect the PSTN phone line to the Telco surge protector (where applicable).
- Shelter/room alarm connections
  - Connect any shelter/room alarm contacts/sensors (where applicable) to the break out board.
- RF output interfaces
  - Connect a broadcast antenna to Output 1 (where applicable).
  - Connect a broadcast antenna to Output 2 (where applicable).
- Repeater AC power
  - Connect the external ground conductor to the repeater.
  - Connect the main AC power cable to the repeater.

**NOTE:** Detailed repeater installation information can be found in the subsequent sections of this manual.

### 3.6 Repeater Setup

The DRU-200 repeater may be installed outdoors (typically on the roof of a building or at the base of a transmission tower) or it may be installed indoors (typically on the top floor of a building nearest to roof, or in a shelter at the base of a transmission tower) in a restricted access location.

#### 3.6.1 Moving the Repeater Cabinet

For shipping purposes, the repeater is attached to a pallet. Some options for moving the repeater are:

- Using a crane to lift the repeater
- Using a pallet tuck
- Using a four wheeled furniture dolly
- Placing casters under the pallet

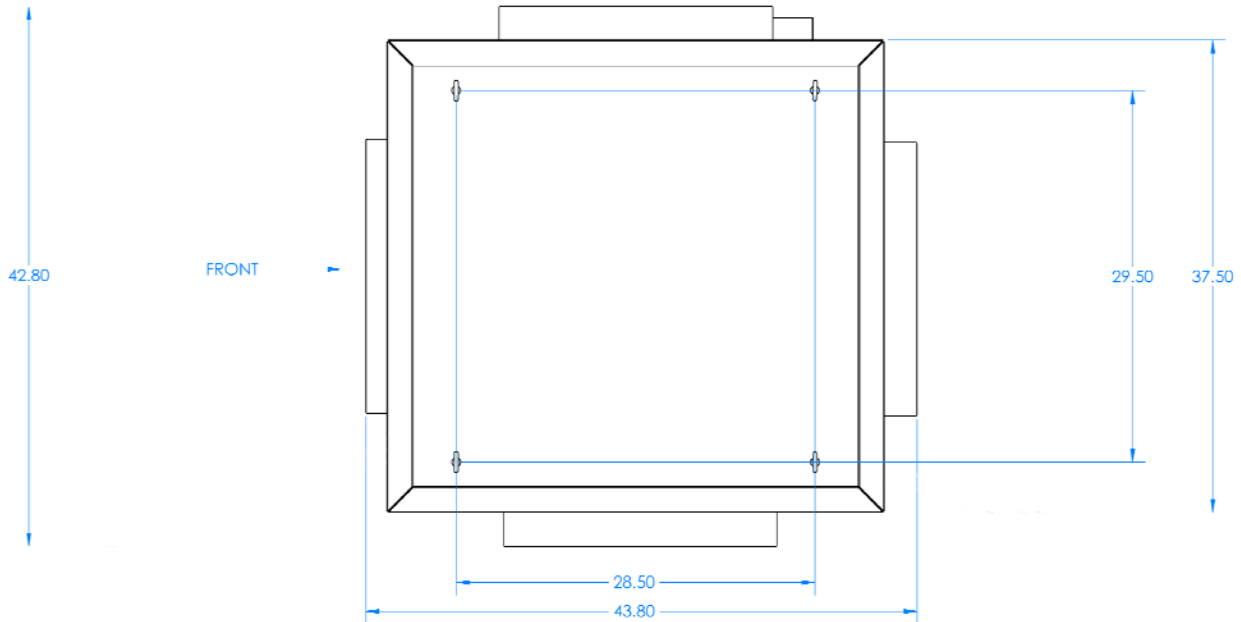
If the repeater is to be lifted using the lifting eyes attached to the repeater cabinet hood (see [Figure 3-1](#)), care should be taken to apply lifting forces vertically at each eye. A spreader bar or other rigging device provided by the installer may be employed for this purpose.



Do not stand under a suspended cabinet, otherwise you could be crushed.

If the repeater is moved from the delivery location to the installation location while still attached to the pallet, a pallet truck or casters are viable options. However, if the repeater cabinet must be removed from the pallet, a narrower furniture dolly is a viable option for moving the repeater cabinet.

**Figure 3-1 Repeater Cabinet Top Down View**



**3.6.2 Installation Surface**

The load bearing strength of the roof or floor where the repeater will be placed should be taken into consideration. The repeater weighs approximately 825 lbs. and rests on an area of 7.85 square feet of roof or floor space.

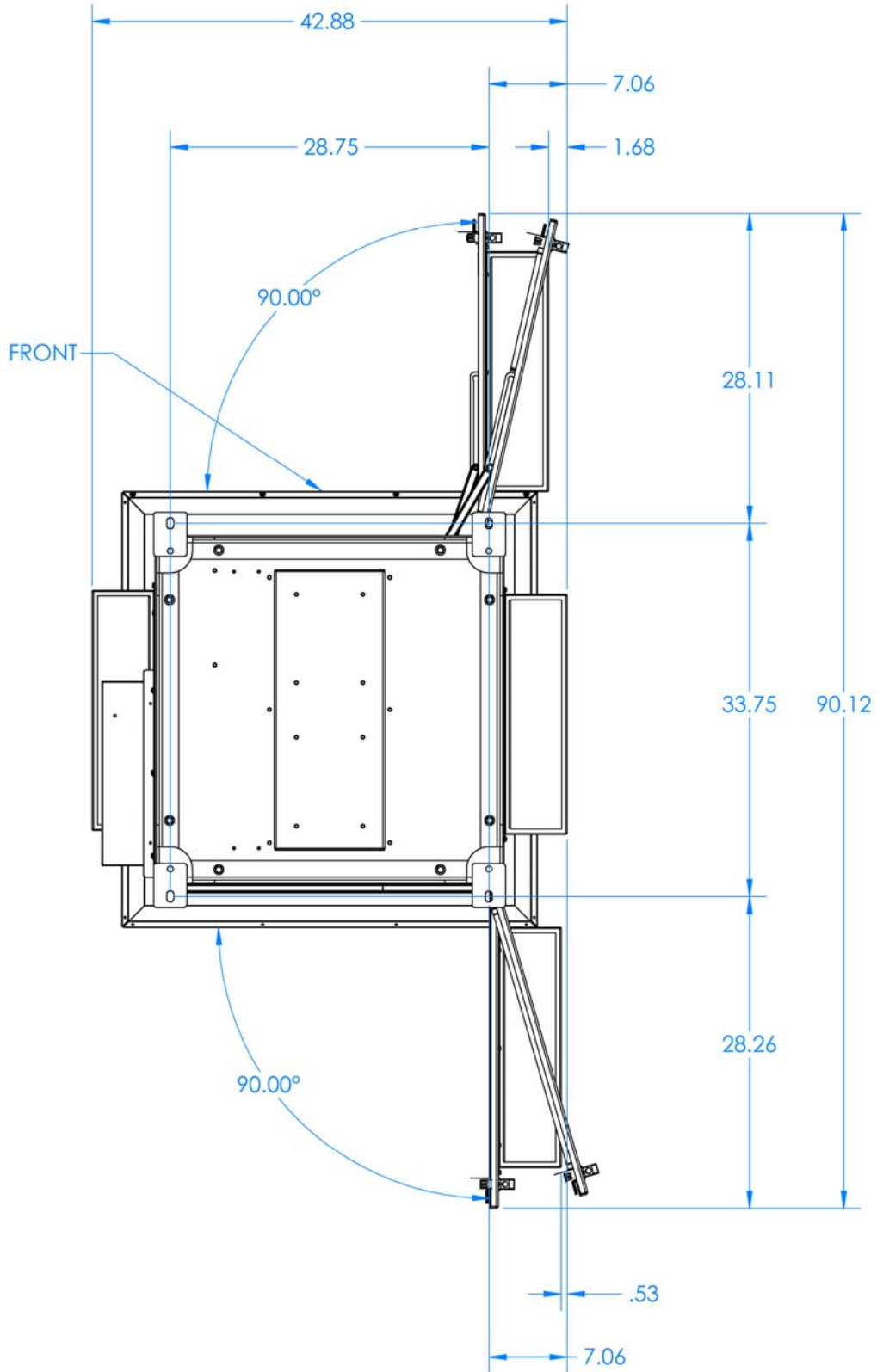
Before installing the repeater cabinet, check the installation surface structure, flatness and suitability.

**3.6.3 Repeater Cabinet Positioning**

	<p>Over tipping the repeater may cause it to fall over, resulting in personal injury or loss of life.</p>
--	---

- The methods described in Section 3.6.1 can be used to move the repeater to the required installation location.
- Unbolt the repeater’s feet from the pallet before attempting to remove it from the pallet.
- Position the repeater according to site drawings (if available).
- The repeater must be bolted to a load frame, to the roof surface, or to the floor at all sites to prevent possible tipping. Please see [Figure 3-2](#) for mounting hole locations.

**Figure 3-2 Repeater Cabinet Bottom Up View**





- The repeater cabinet should be positioned within the room to allow for adequate ventilation.
- Sufficient space must be made available in front of the cabinet so that the front doors to be opened and closed, allowing the installer to access the PDU, BMS, LNA, DBPF, LBE, HBE, TRMS, dial-up modem, DR filter box, HPA's and HPA PSU.
- Sufficient space must be made available behind the cabinet so that the rear doors can be opened and closed, allowing the installer to access the 12 VDC battery, U-link/couplers, output coupler(s) and component rear panel interfaces (connectors).
- Sufficient space must be made available on the left side of the cabinet, allowing for cable connections to surge protectors as well as routing ground, AC, communications and alarm wires/cables into the cabinet.
- Sufficient space must be made available above the cabinet for the removal or installation of the cabinet hood, permitting the installer to access the fan box.

#### 3.6.4 Unpacking

Inspect all crates and boxes for exterior damage and make note of any dents, broken seals, or other indications of improper handling. In the event any in transit damage is discovered, report it to UBS.

Remove the repeater cabinet and components (assemblies) from their crates and boxes. Verify that all materials are enclosed as listed on the packing slip and report any shortages to UBS.

Open the front and rear doors on the repeater cabinet and inspect the interior for packing material and carefully remove any material that is found. Do not remove any labeling or tags from the cabinet, drawers/modules, wires/cables or connectors; these are identification markers that make assembly of the repeater system much easier.

#### 3.7 Electronics Compartment Components

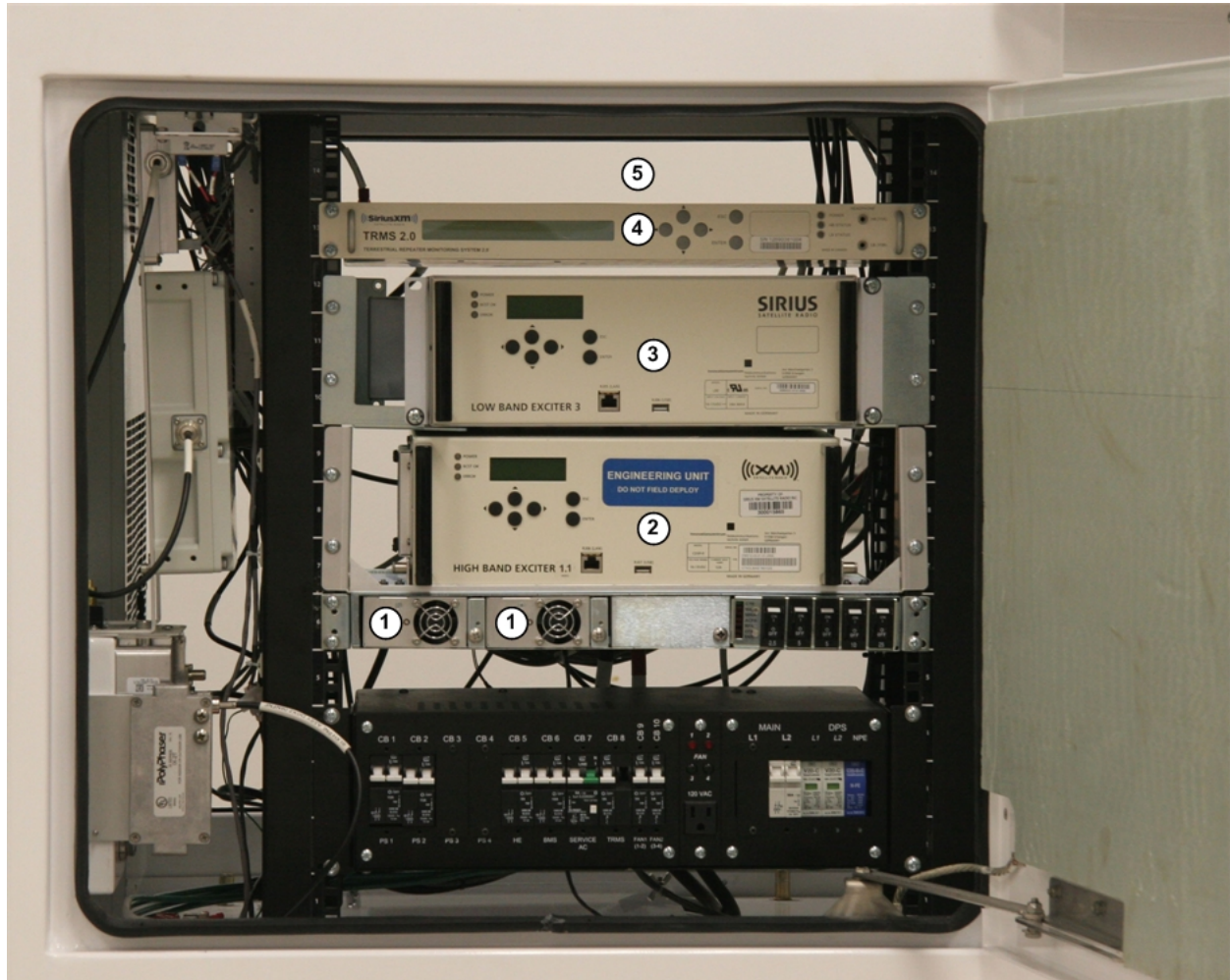


Always ensure that the circuit breaker in the building/site electrical service panel or AC disconnect device is in the OFF position prior to beginning any installation work in the repeater cabinet. This will prevent injury caused by electric shock and prevent damage to equipment.

Several components must be installed in the electronics compartment:

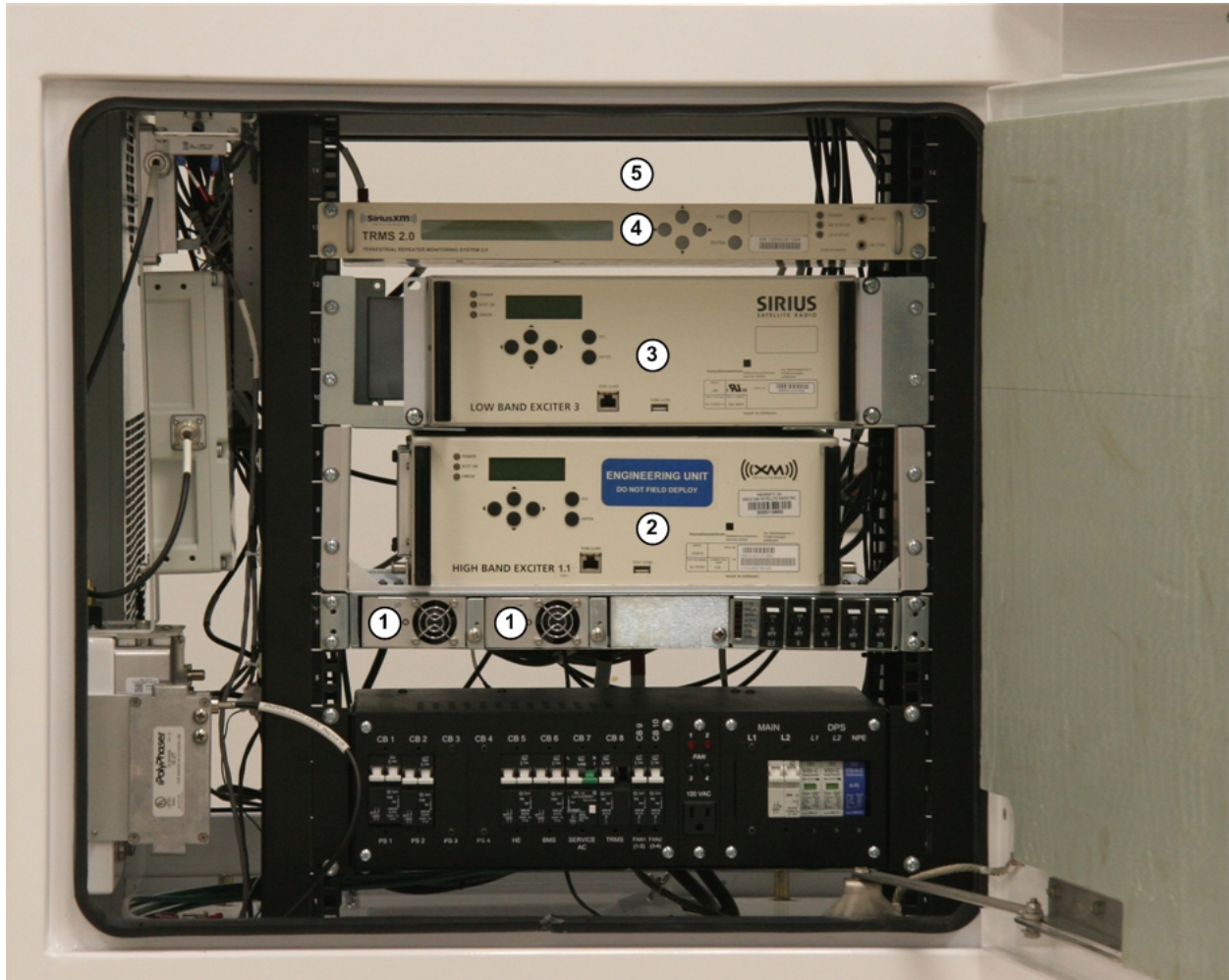
- Battery Management System (BMS) 12 VDC Rectifiers
- High Band Exciter (HBE)
- Low Band Exciter (LBE)
- Terrestrial Repeater Monitoring System (TRMS)
- Dial-up Modem (site dependent)

**Figure 3-3 Un-populated Electronics Compartment**



- 1) Empty Slot for BMS 12 VDC Rectifier Module
- 2) Bracket for HBE
- 3) Bracket for LBE
- 4) Empty Slot for TRMS
- 5) Shelf for Dial-up Modem

**Figure 3-4 Populated Electronics Compartment**



- 1) BMS 12 VDC Rectifier Module
- 2) HBE
- 3) LBE
- 4) TRMS
- 5) Location of Dial-up modem

### 3.7.1 BMS 12 VDC Rectifier Module

The BMS mounting shelf includes two (2) empty slots for the 12 VDC rectifier modules. Please refer to [Figure 3-3](#), [Figure 3-4](#) or drawing SX03-10000-03-D01 for the mounting position of the rectifiers.

The BMS 12 VDC rectifier modules should be installed in the following sequence:

1. Slide the first rectifier module into the left-most slot until it stops – see [Figure 3-7](#).
2. **Secure the rectifier module to the shelf by tightening the Phillips pan head screw until it stops.** As the screw is tightened, the rectifier module will slide all the way into the slot.
3. Slide the second rectifier module into the middle slot until it stops and repeat step 2.

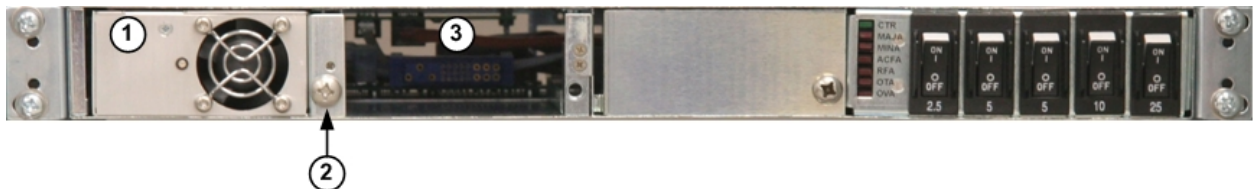
**Figure 3-5 12 VDC Rectifier Module Front and Rear Panel**



**Figure 3-6 BMS Mounting Shelf with Controller**



**Figure 3-7 BMS Mounting Shelf with 1 Rectifier Module Installed**



- 1) 12 VDC Rectifier Module
- 2) **Mounting Screw (supplied with rectifier module)**
- 3) Empty Slot for Second 12 VDC Rectifier Module

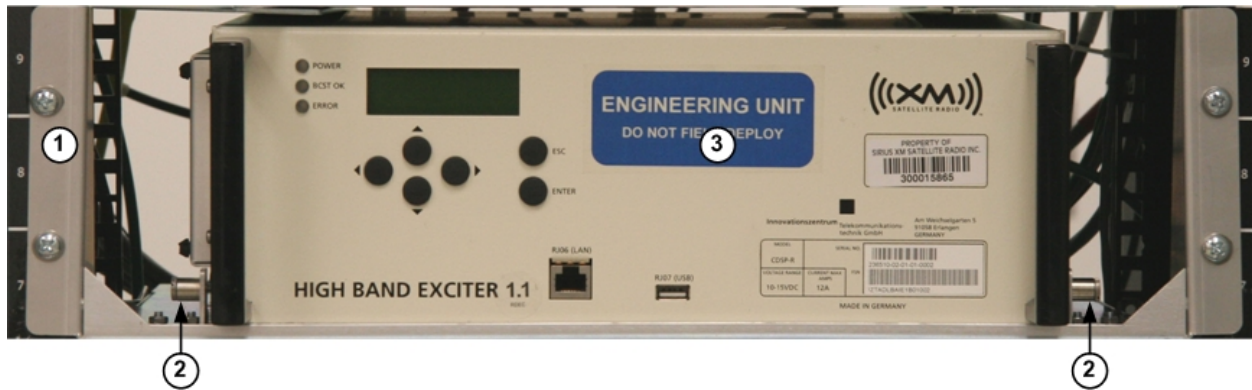
### 3.7.2 High Band Exciter (HBE)

The electronics compartment includes a custom mounting bracket for the HBE. Please refer to [Figure 3-3](#), [Figure 3-4](#) or drawing SX03-10000-03-D01 for the mounting position of the HBE.

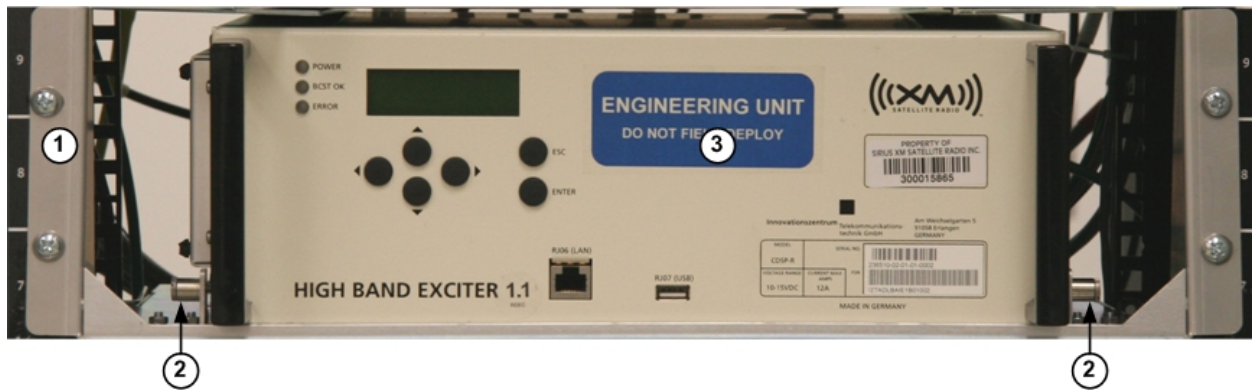
The HBE should be installed in the following sequence:

1. Place the HBE on the custom mounting bracket located above the BMS.
2. Secure the HBE to the custom mounting bracket by tightening the four (4) knurled screws (2 located on either side of the HBE; 1 near the front of the HBE and 1 near the back of the HBE) – see [Figure 3-9](#).

**Figure 3-8 HBE Mounting Bracket**



**Figure 3-9 HBE Mounting Bracket with HBE**



- 1) HBE Mounting Bracket
- 2) Knurled Screw
- 3) HBE

### 3.7.3 Low Band Exciter (LBE)

The electronics compartment includes a custom mounting bracket for the LBE. Please refer to [Figure 3-3](#), [Figure 3-4](#) or drawing SX03-10000-03-DO1 for the mounting position of the LBE.

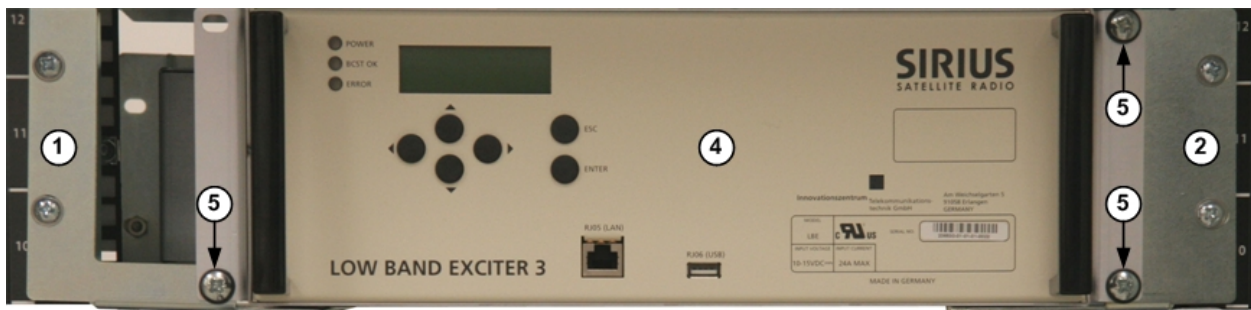
The LBE should be installed in the following sequence:

1. Place the LBE on the custom mounting bracket located above the HBE.
2. Secure the LBE to the custom mounting bracket by installing three (3) Phillips pan head screws (1 located on the left bracket and 2 located on the right bracket) – see [Figure 3-11](#).

**Figure 3-10 LBE Mounting Brackets**



**Figure 3-11 LBE Mounting Brackets with LBE**



- 1) LBE Mounting Bracket (left side)
- 2) LBE Mounting Bracket (right side)
- 3) Mounting Screw Hole
- 4) LBE
- 5) Mounting Screw

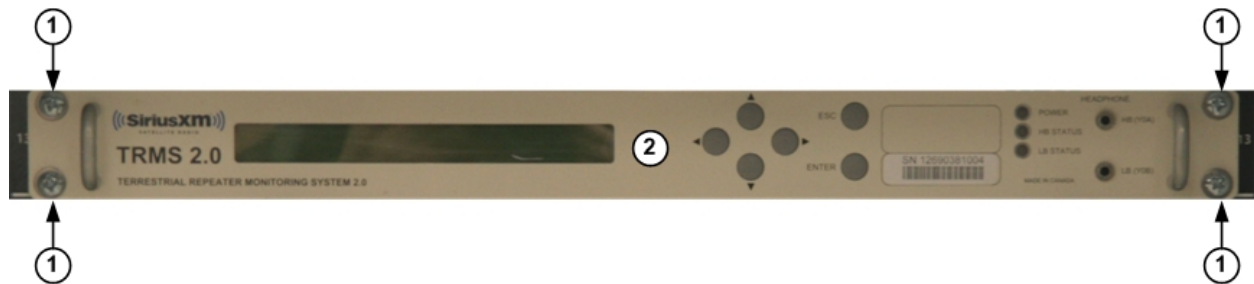
### 3.7.4 Terrestrial Repeater Monitoring System (TRMS)

The electronics compartment mounting rails includes an open slot for the TRMS. Please refer to [Figure 3-3](#), [Figure 3-4](#) or drawing SX03-10000-03-D01 for the mounting position of the TRMS.

The TRMS should be installed in the following sequence:

1. Slide the TRMS into the open slot located above the LBE and secure the TRMS by installing four (4) Phillips pan head screws (2 located on either side of the TRMS) – see [Figure 3-12](#).

**Figure 3-12 TRMS in Rack**



- 1) Mounting Screw
- 2) TRMS

### 3.7.5 Dial-up Modem

The DRU-200 will be equipped with a dial-up modem. The electronics compartment mounting rails include a shelf which the dial-up modem can be mounted on. Please refer to [Figure 3-3](#), [Figure 3-4](#) or drawing SX03-10000-03-D01 for the mounting position of the dial-up modem.

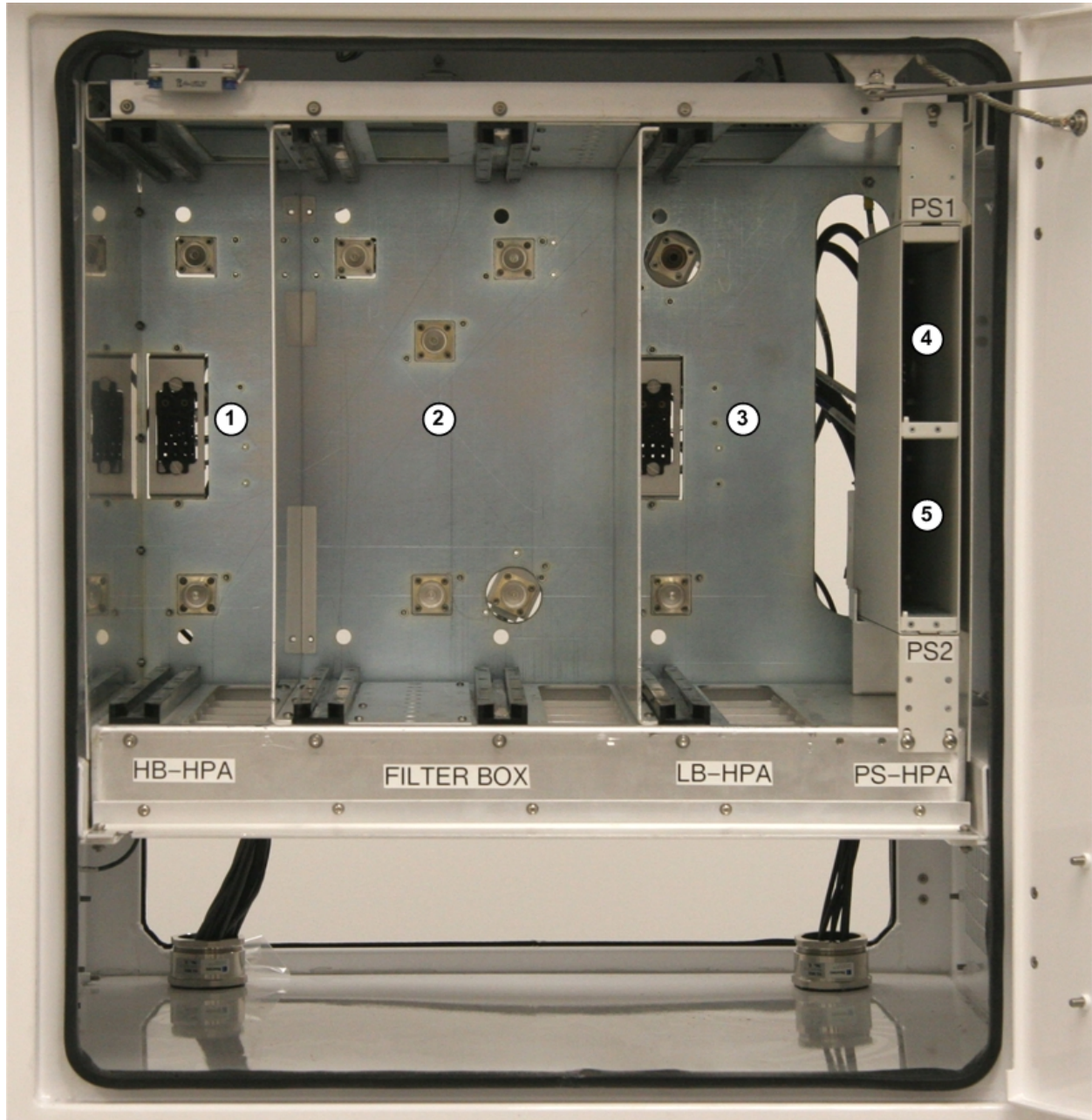
## 3.8 HPA Compartment Components

	<p>Always ensure that the circuit breaker in the building/site electrical service panel or AC disconnect device is in the OFF position prior to beginning any installation work in repeater cabinet. This will prevent injury caused by electric shock and prevent damage to equipment.</p>
--	---

During the installation procedure, several components must be installed in the HPA compartment:

- DR Filter Box
- Low Band and High Band HPA's
- HPA 30 VDC Rectifiers

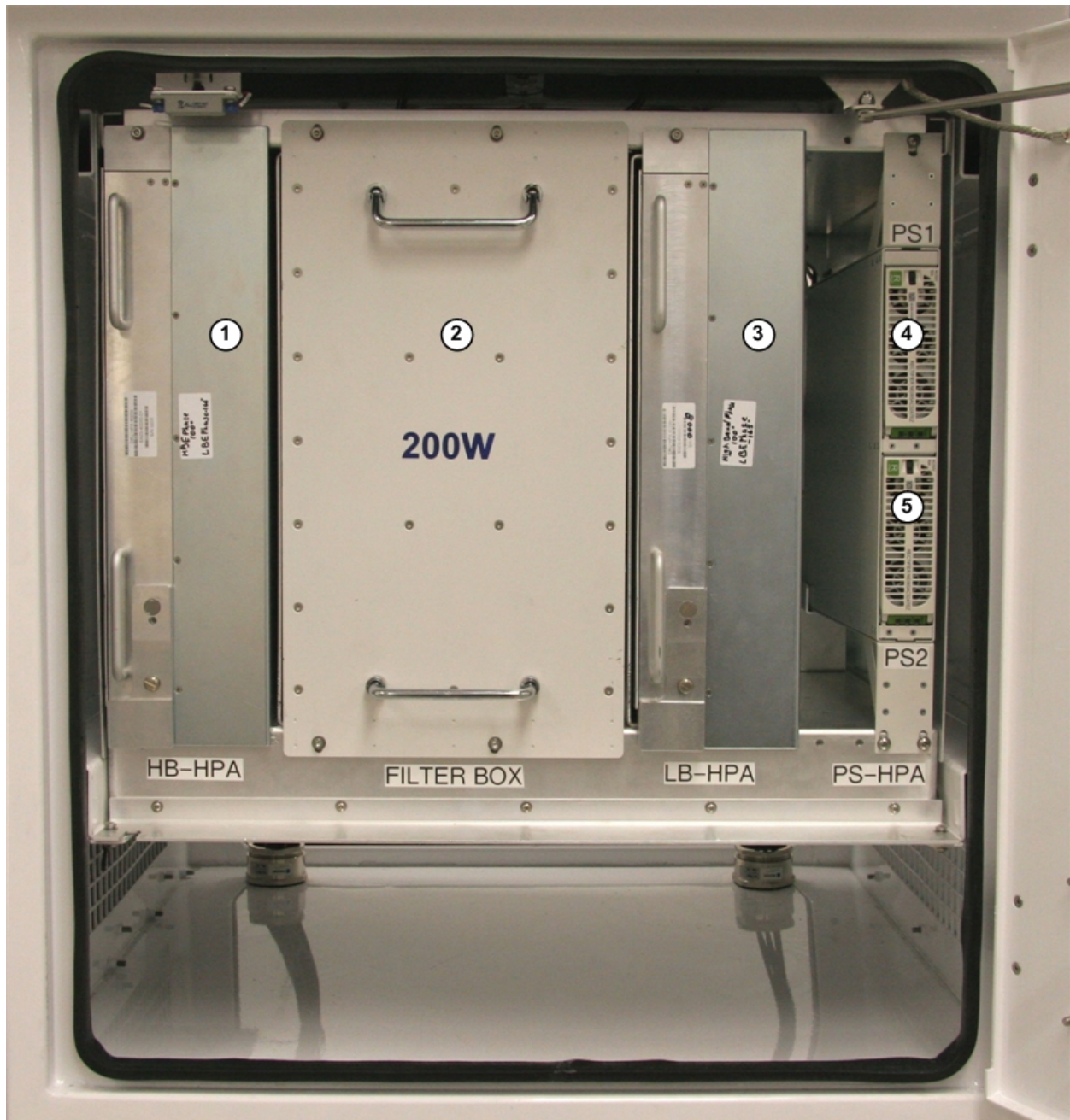
**Figure 3-13 Un-populated HPA Compartment**



- 1) Empty Slot for HB HPA 1
- 2) Empty Slot for DR Filter Box
- 3) Empty Slot for LB HPA 2
- 4) Empty Slot for HB HPA PS 1 (30 VDC Rectifier Module)
- 5) Empty Slot for LB HPA PS 2 (30 VDC Rectifier Module)




**Figure 3-14 Populated HPA Compartment**



- 1) HB HPA 1
- 2) DR Filter Box
- 3) LB HPA 2
- 4) HB HPA PS 1 (30 VDC Rectifier Module)
- 5) LB HPA PS 2 (30 VDC Rectifier Module)

### 3.8.1 Combined DRU Pre-installation

	<p>Several components mounted on the HPA compartment frame backplane must be loosened prior to installing the DR filter box and HPA's. Not doing so could damage a number of blind mate connectors.</p>
---	---

During product shipment, shear forces may cause some components mounted to the HPA compartment frame backplane to become slightly misaligned. It is important that these components are loosened prior to installing the DR filter box and HPA's. Loosening these components allows the DR filter box and HPA's to slide into the HPA compartment frame with less restrictions.

Please refer to [Figure 3-15](#) for the locations of the components that should be loosened.


1. Loosen the two (2) 8-32 socket head cap screws which secure the LB U-link/coupler to the backplane ([Figure 3-15](#), item 1).
2. Loosen the two (2) 8-32 socket head cap screws which secure the HB U-link/coupler to the backplane ([Figure 3-15](#), item 2).
3. Loosen the two (2) 8-32 socket head cap screws which secure the combined output coupler to the backplane ([Figure 3-15](#), item 3).
4. Loosen the two (2) 8-32 socket head cap screws which secure the LB filter input adapter to the backplane ([Figure 3-15](#), item 4).
5. Loosen the two (2) 8-32 socket head cap screws which secure the LBD filter input adapter to the backplane ([Figure 3-15](#), item 5).
6. Loosen the two (2) 8-32 socket head cap screws which secure the LBD filter output to the backplane ([Figure 3-15](#), item 6).
7. Loosen the two (2) 8-32 socket head cap screws which secure the HB filter input adapter to the backplane ([Figure 3-15](#), item 7).

Once the HPA compartment frame backplane components have been loosened, the installer can proceed to install the DR filter box and HPA's.

*Figure 3-15 Combined DRU HPA Compartment Frame Backplane*

PICTURE TBD

### 3.8.2 Independent DRU Pre-installation

	<p>Several components mounted on the HPA compartment frame backplane must be loosened prior to installing the DR filter box and HPA's. Not doing so could damage a number of blind mate connectors.</p>
---	---

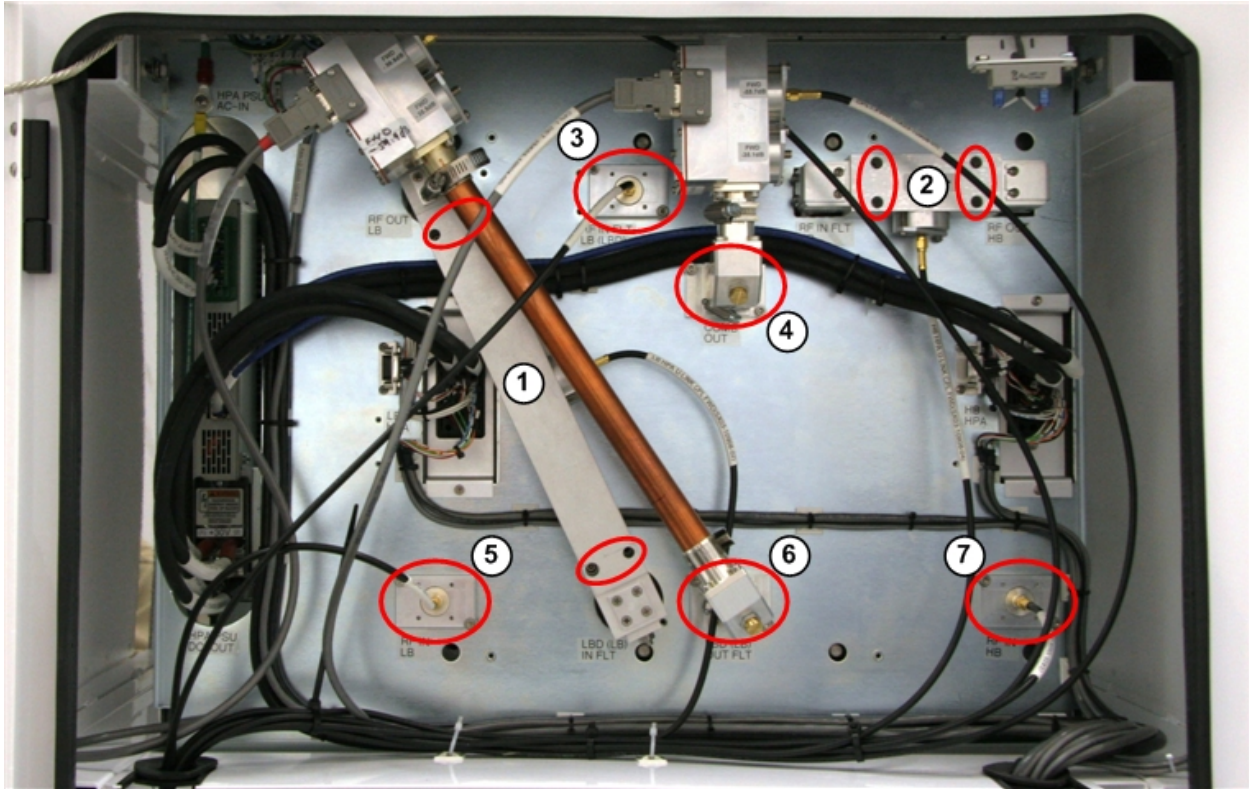
During product shipment, shear forces may cause some components mounted to the HPA compartment frame backplane to become slightly misaligned. It is important that these components are loosened prior to installing the DR filter box and HPA's. Loosening these components allows the DR filter box and HPA's to slide into the HPA compartment frame with less restrictions.

Please refer to [Figure 3-16](#) for the locations of the components that should be loosened.

8. Loosen the two (2) 8-32 socket head cap screws which secure the LB U-link/coupler to the backplane ([Figure 3-16](#), item 1).
9. Loosen the two (2) 8-32 socket head cap screws which secure the HB U-link/coupler to the backplane ([Figure 3-16](#), item 2).
10. Loosen the two (2) 8-32 socket head cap screws which secure the LBD filter input adapter to the backplane ([Figure 3-16](#), item 3).
11. Loosen the two (2) 8-32 socket head cap screws which secure the combined output coupler to the backplane ([Figure 3-16](#), item 4).
12. Loosen the two (2) 8-32 socket head cap screws which secure the LB filter input adapter to the backplane ([Figure 3-16](#), item 5).
13. Loosen the two (2) 8-32 socket head cap screws which secure the independent output coupler 90° elbow to the backplane ([Figure 3-16](#), item 6).
14. Loosen the two (2) 8-32 socket head cap screws which secure the HB filter input adapter to the backplane ([Figure 3-16](#), item 7).

Once the HPA compartment frame backplane components have been loosened, the installer can proceed to install the DR filter box and HPA's.

**Figure 3-16 Independent DRU HPA Compartment Frame Backplane**



### 3.8.3 DR Filter Box

	<p>Always install the DR filter box with the aid of a second handler. The DR filter box weighs approximately 50 lbs.</p>
--	--

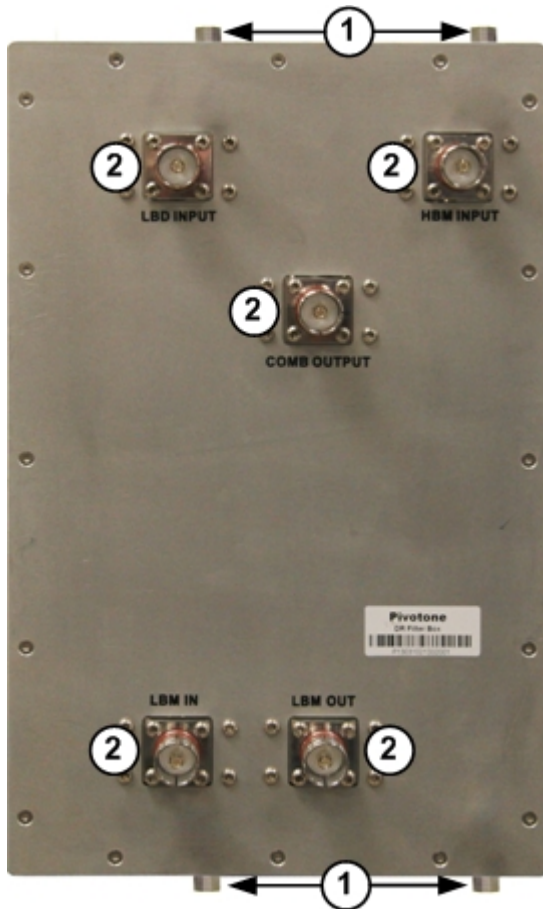
The HPA compartment frame includes a slot for the DR filter box. Please refer to [Figure 3-13](#), [Figure 3-14](#) or drawing SX03-10000-03-D01 for the mounting position of the DR filter box.

The DR filter box should be installed in the following sequence:

1. Using two handlers, one located on each side of the DR filter box, lift the DR filter box and position it level to the open space in the HPA compartment frame.
2. Carefully line up the DR filter box sliders (2 located on the top and 2 located on the bottom of the DR filter box) with the slide rails mounted in the HPA compartment frame – see [Figure 3-18](#).
3. Slowly push the DR filter box into the HPA compartment frame until it stops.

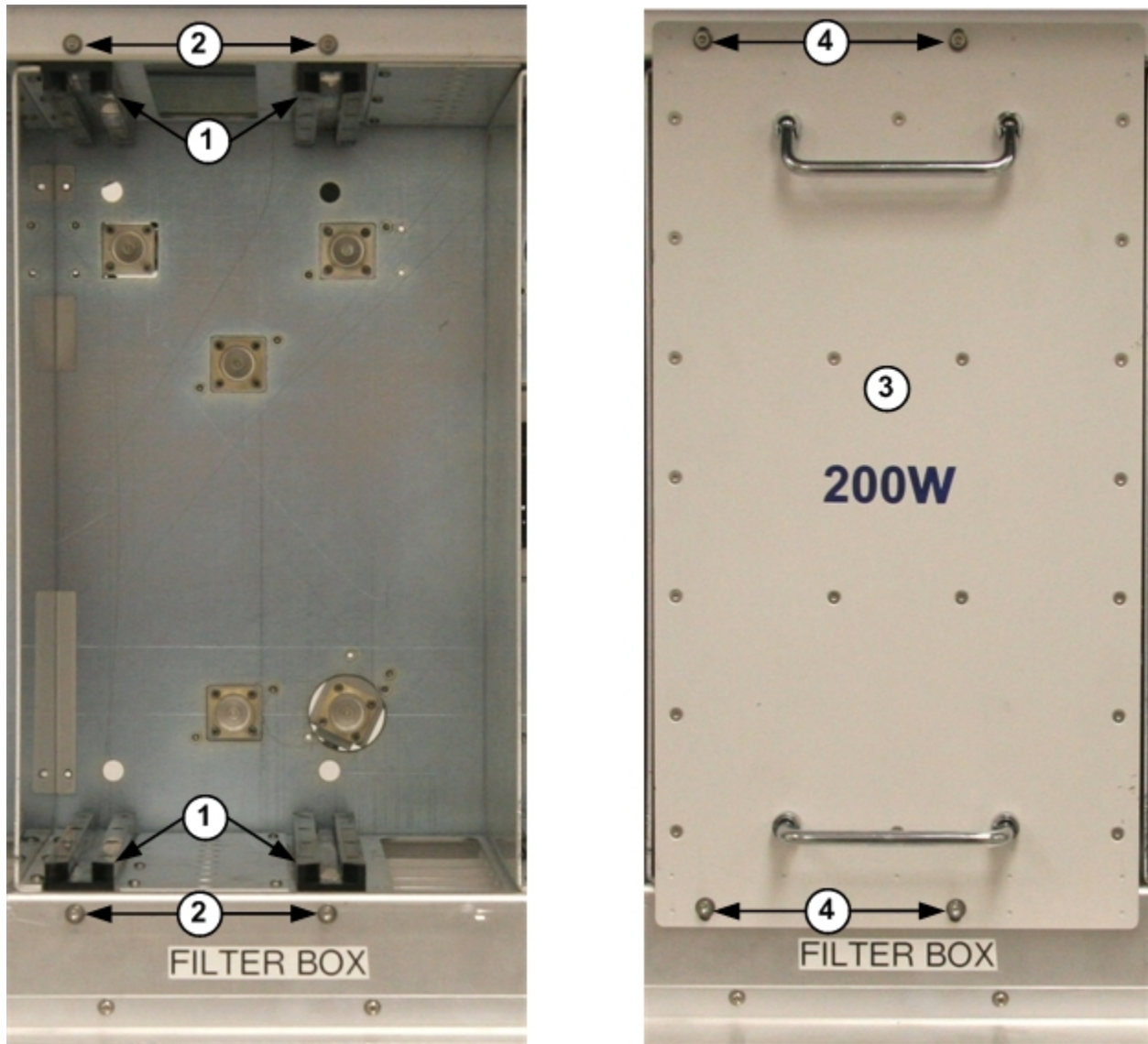
4. There are five (5) 7/8" blind mate connectors located on the DR filter box rear panel which are aligned with corresponding connectors on the HPA compartment frame backplane – see [Figure 3-17](#). Ensure that the connectors are aligned properly and slowly push the DR filter box into the backplane until it stops. At this point, the back side of the DR filter box front panel should be flush with the HPA compartment frame.
5. Secure the DR filter box in place by tightening the four (4) 10-32 Phillips head captive screws (2 located on the top and 2 located on the bottom of the DR filter box) with a torque rating of 19.2 Inch Lbs. – see [Figure 3-18](#).

**Figure 3-17 Independent DR Filter Box Rear Panel**




- 1) Slider
- 2) 7/8" Blind Mate Connector

**Figure 3-18 DR Filter Box Compartment (before and after)**



- 1) Slide Rail
- 2) Mounting Screw Hole
- 3) Independent DR Filter Box
- 4) 10-32 Phillips Head Captive Mounting Screw

### 3.8.4 High Power Amplifier (HPA)

	<p>Always install the high power amplifiers with the aid of a second handler. The high power amplifier weighs approximately 55 lbs.</p>
---	---

The HPA compartment frame includes two (2) slots for the HPA's. Please refer to [Figure 3-13](#), [Figure 3-14](#) or drawing SX03-10000-03-D01 for the mounting position of the HPA's.

The HPA's should be installed in the following sequence:

1. Before the HPA is installed in the HPA compartment frame, remove the magnetic plate from the HPA front panel – see [Figure 3-19](#).
2. Using two handlers, one located on each side of the HPA, lift the HPA and position it level to the open space in the HPA compartment frame to the left of the DR filter box.
3. Carefully line up the HPA sliders (1 located on the top and 1 located on the bottom of the HPA) with the slide rails mounted in the HPA compartment frame – see [Figure 3-21](#).
4. Slowly push the HPA into the HPA compartment frame until it stops.
5. There are three (3) blind mate connectors located on the HPA rear panel which are aligned with corresponding connectors on the HPA compartment frame backplane – see [Figure 3-20](#). Ensure that the connectors are aligned properly and slowly push the HPA into the backplane until it stops. At this point, the back side of the HPA front panel should be flush with the HPA compartment frame.
6. Secure the HPA in place by tightening the 10-32 Phillips head captive screw (located at the top of the HPA front panel) with a torque rating of 19.2 Inch Lbs. – see [Figure 3-21](#).
7. Place the magnetic plate at the bottom of the HPA front panel and tighten the 10-32 Phillips head captive screw with a torque rating of 19.2 Inch Lbs. Note: The magnetic plate must be installed in order for the HPA to power up later on.
8. Repeat steps 1 through 7 for the second HPA, which is mounted in the slot to the right of the DR filter box.

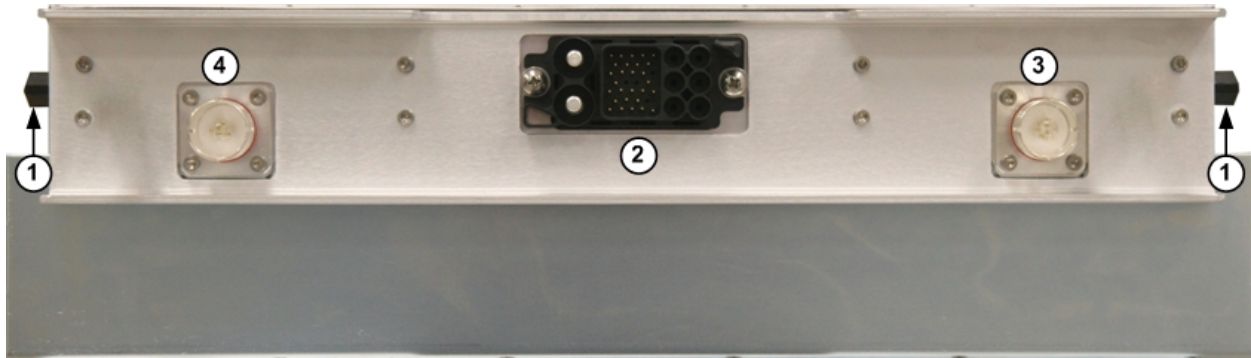


**Figure 3-19 HPA Front Panel**



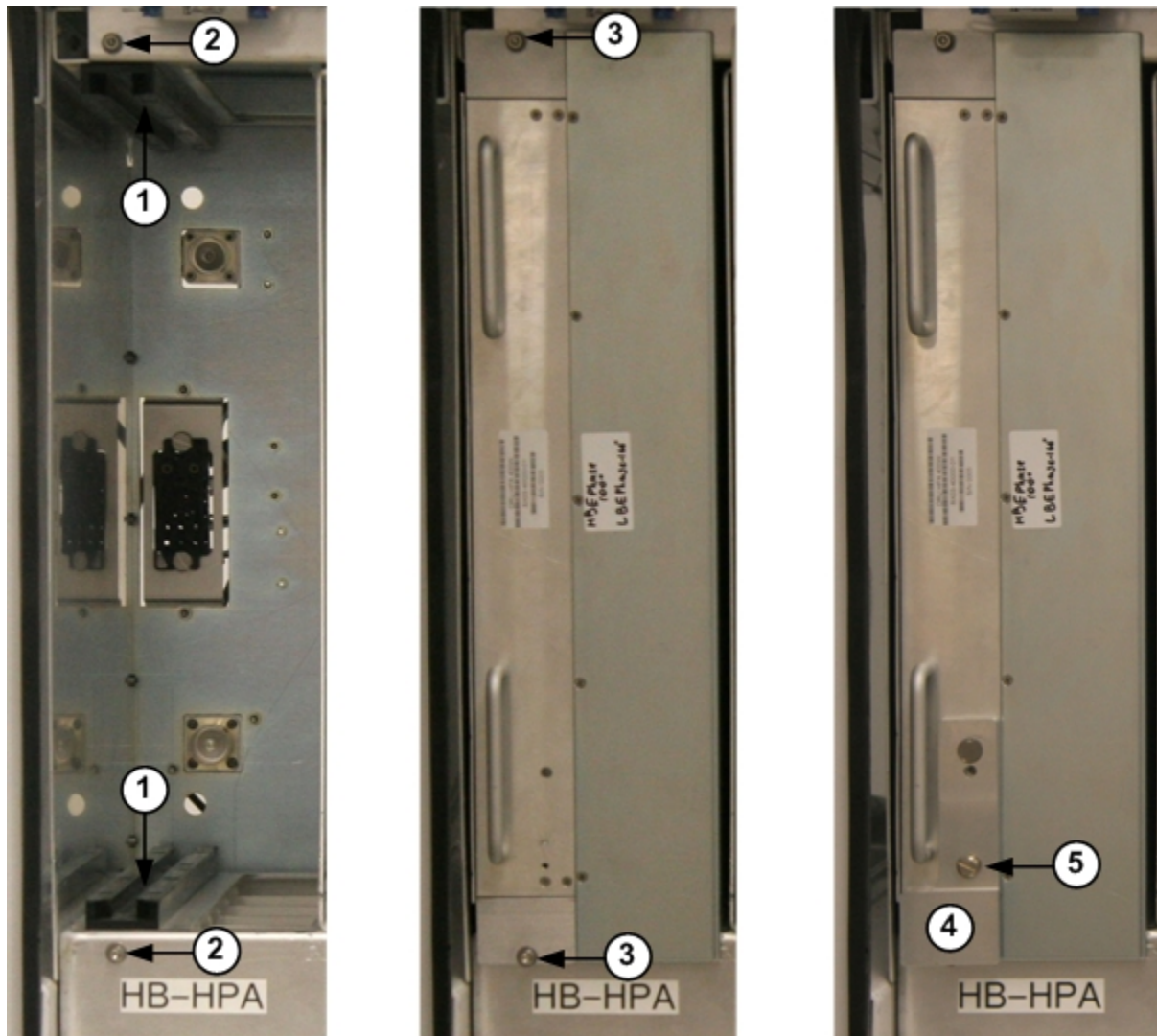
- 1) Handle
- 2) Magnetic Plate
- 3) Magnetic Plate 10-32 Phillips Head Captive Mounting Screw

**Figure 3-20 HPA Rear Panel**




- 1) Slider
- 2) DC and Control Connector
- 3) 7/8" Blind Mate RF Input Connector
- 4) 7/8" Blind Mate RF Output Connector

**Figure 3-21 HPA Compartment (before and after)**



- 1) Slide Rail
- 2) Mounting Screw Hole Location
- 3) 10-32 Phillips Head Captive Mounting Screw
- 4) Magnetic Plate
- 5) Magnetic Plate 10-32 Phillips Head Captive Mounting Screw

### 3.8.5 Finalize DR Filter Box and HPA Installation

	<p>Open or loose RF connections during operation may cause electric arcs that can cause burns and eye injuries, as well as damage equipment. Always ensure that all HPA compartment frame backplane components are tightened once the DR filter box and HPA's are installed.</p>
---	--

Once the installation of the DR filter box and HPA's is complete, the components which are mounted to the HPA compartment frame backplane must be secured in place. A torque rating of 10.8 Inch Lbs. must be used to tighten the 8-32 socket head cap screws which secure these components to the HPA compartment frame backplane.

### 3.8.6 HPA PSU 30 VDC Rectifier Module

The HPA PSU mounting shelf includes two (2) empty slots for the HPA PSU 30 VDC rectifier modules. Please refer to [Figure 3-13](#), [Figure 3-14](#) or drawing SX03-10000-03-D01 for the mounting position of the rectifier modules.

The HPA PSU 30 VDC rectifier modules should be installed in the following sequence:

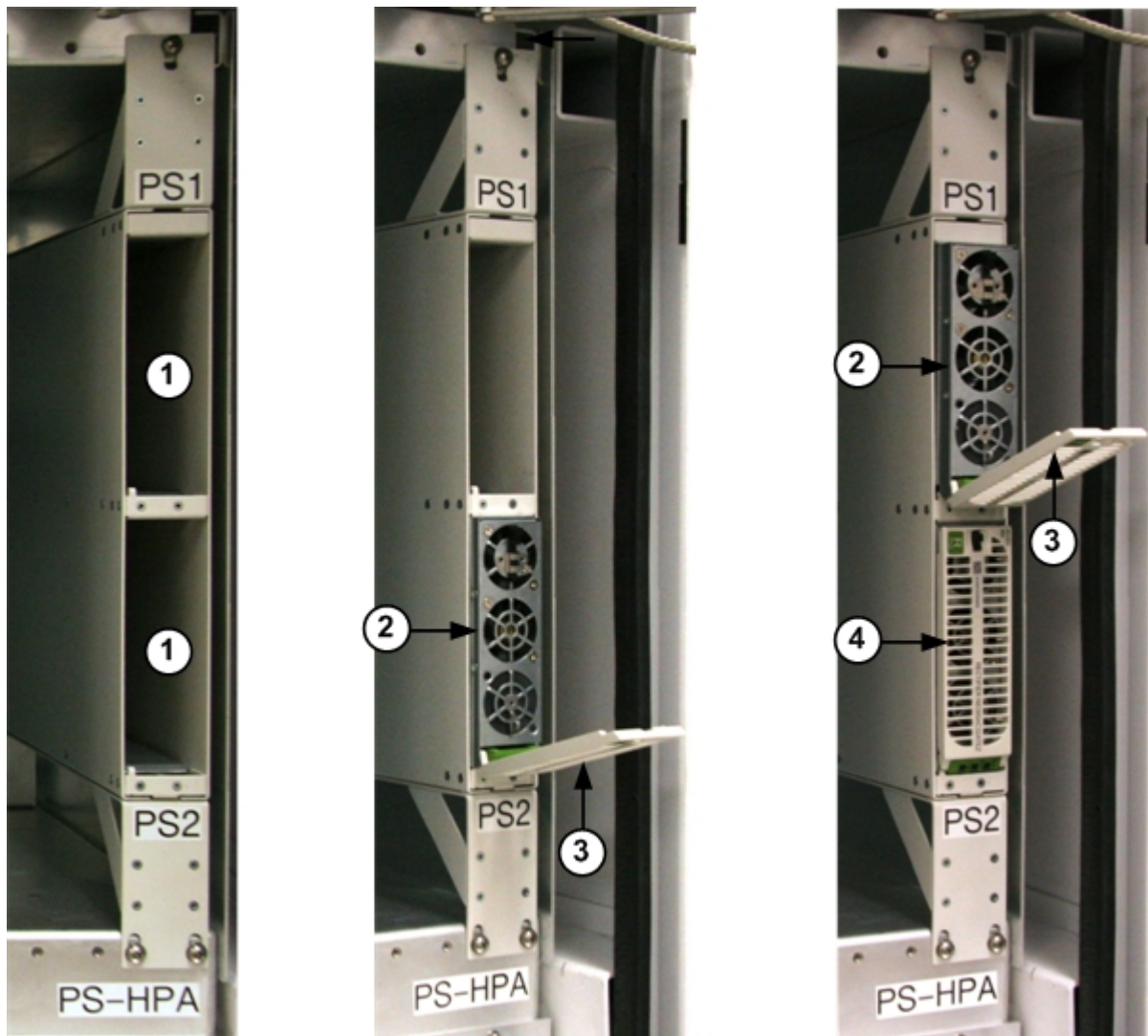
1. Slide the black release button on the rectifier module front grill/cover cover to the right to release the grill/cover from the front of the rectifier module.
2. Position the rectifier module so that the open grill cover is facing down.
3. Slide the rectifier module into either of the empty slots on the HPA PSU mounting shelf until it stops – see [Figure 3-23](#).
4. To secure the rectifier module in place, lift the grill cover up and push it towards the rectifier module until it clicks in place. As the grill cover is pushed in place, the rectifier module will slide all the way into the slot.
5. Repeat steps 1 through 4 for the second rectifier module.

**Figure 3-22 HPA PSU 30 VDC Rectifier Module**



- 1) Front Grill/Cover
- 2) Front Grill/Cover Release Button
- 3) Rear Panel

**Figure 3-23 HPA PSU Shelf (before and after)**

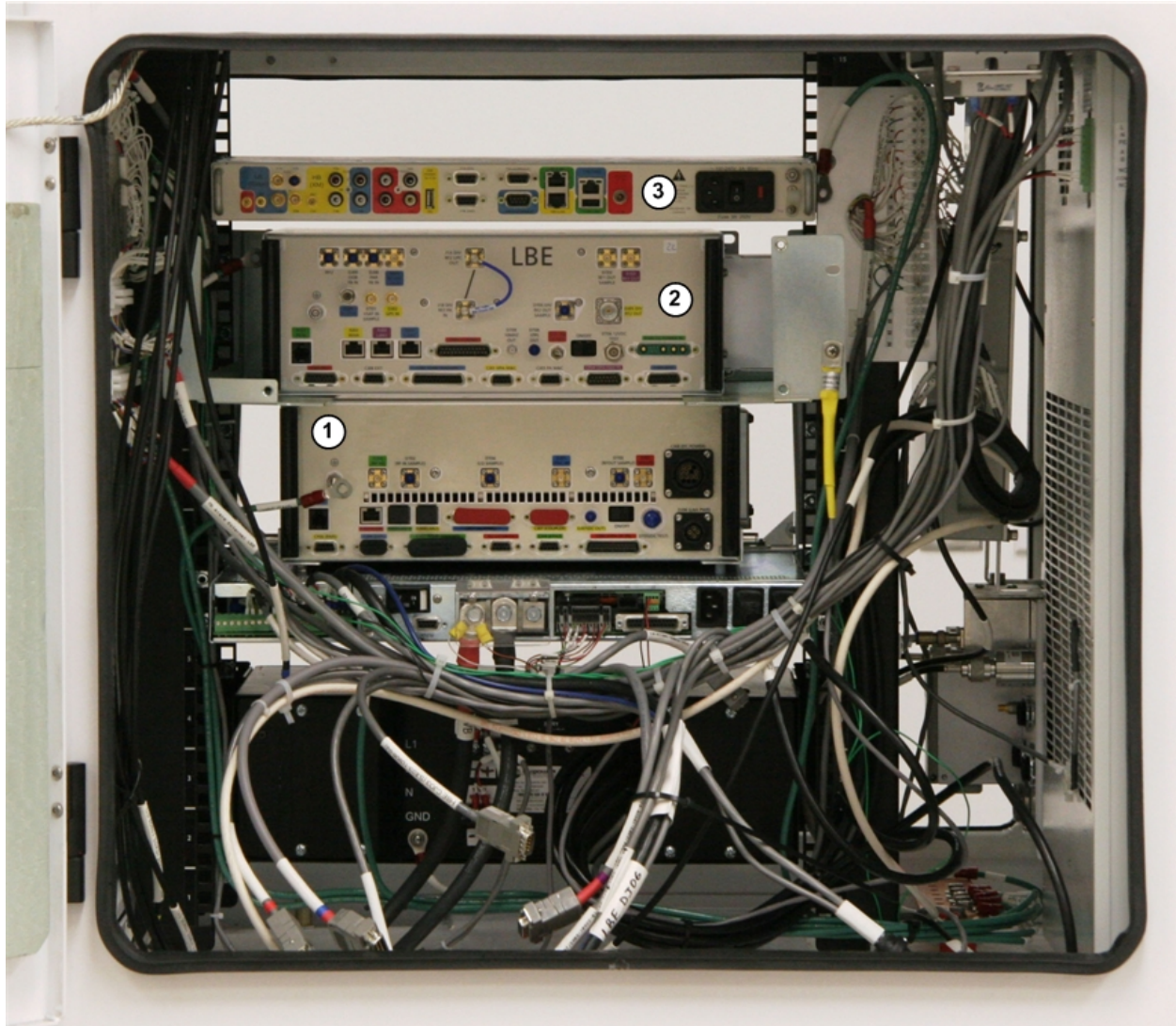


- 1) Open Slot for Rectifier Module
- 2) Disengaged Rectifier Module with Open Grill Cover
- 3) Open Grill Cover
- 4) Fully Secured Rectifier Module with Closed Grill Cover

### 3.9 Internal Wire/Cable Connections

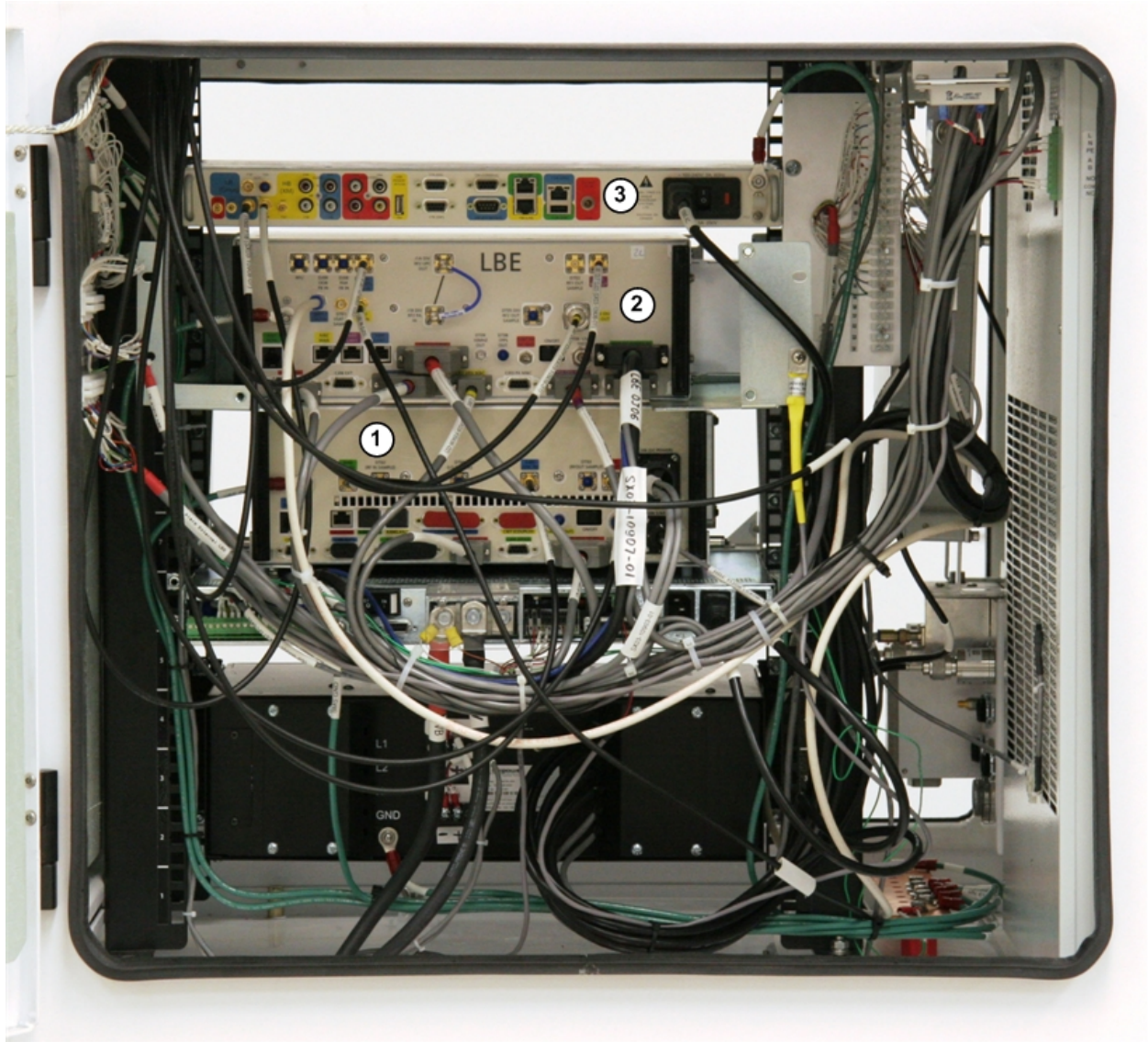
Once the HBE, LBE, TRMS and Dial-up modem (where applicable) are mounted in the electronics cabinet, a number of wires/cables must be connected to these components.

**Figure 3-24 Electronics Compartment (with no connections)**



- 1) HBE Rear Panel
- 2) LBE Rear Panel
- 3) TRMS Rear Panel

**Figure 3-25 Electronics Compartment Components (with connections)**



### 3.9.1 Ground and AC Connections

All repeater cabinet internal ground wires are pre-wired to the cabinet ground bar. During the installation procedure, several components must be connected to the ground bar via the pre-wired ground wires. Please see the subsequent sections of this manual.

All repeater cabinet internal AC components are pre-wired to the cabinet PDU. Only the cabinet PDU needs to be connected to building/site electrical service panel (or AC disconnect device).

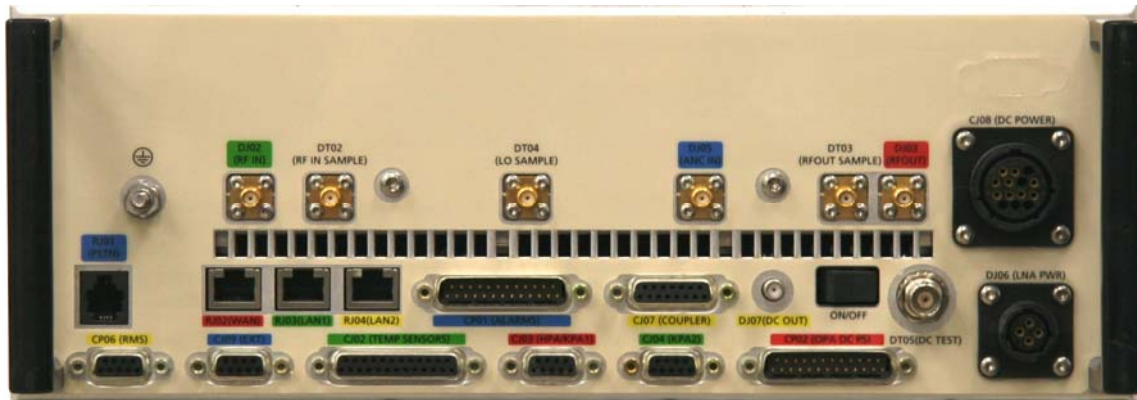
### 3.9.2 High Band Exciter (HBE)

During the installation procedure, a number of wires/cables must be connected to the HBE rear panel. Please refer to [Table 3-6](#) or drawing SX03-10900-03-D06.

The cables should be connected in the order that they appear in [Table 3-6](#).

	<p>Any RF cable, which is terminated with a SMA connector, should be tightened with a 5/16" torque wrench to avoid over tightening and damaging the cable connector or mating connector.</p>
--	--

**Figure 3-26 HBE Rear Panel**




**Table 3-6 HBE Rear Panel Connections**

HBE Port	Name	Type	Cable Number
N/A	N/A	Ground Post	SX03-10926-05
CJ03	HPA/KPA1	DB-9 (F)	SX03-10924-02
CP02	OPA DC PS	DB-25 (M)	SX03-10919-01
RJ02	WAN	RJ-45	SX03-10905-02
RJ03	LAN	RJ-45	SX03-10905-03
DJ06	LNA PWR	4-pos CPC	SX03-10902-01
CJ08	DC POWER	14-pos CPC	SX03-10903-01
DJ02	RF IN	SMA (F), 50 ohm	SX03-10909-02
DJ05	ANC IN	SMA (F), 50 ohm	SX03-10908-04
DJ03	RF OUT	SMA (F), 50 ohm	SX03-10908-03

### 3.9.3 Low Band Exciter (LBE)

During the installation procedure, a number of wires/cables must be connected to the LBE rear panel. Please refer to [Table 3-7](#) or drawing SX03-10900-03-D06.

The cables should be connected in the order that they appear in [Table 3-7](#).

	<p>Any RF cable, which is terminated with a SMA connector, should be tightened with a 5/16" torque wrench to avoid over tightening and damaging the cable connector or mating connector.</p>
---	--

**Figure 3-27 LBE Rear Panel**






**Table 3-7 LBE Rear Panel Connections**

LBE Port	Name	Type	Cable Number
N/A	N/A	Ground Post	SX03-10926-06
CJ02	OC1	DB-15 (F)	SX03-10904-02
CJ06	TEMP SENSORS	DB-25 (F)	SX03-10901-01
CJ01	HPA M&C	DB-9 (F)	SX03-10924-01
CP04	OPA-FAN-PS	DB-15 (M)	SX03-10920-01
CJ05	OC2	DB-15 (F)	SX03-10904-01
RJ02	WAN	RJ-45	SX03-10905-04
RJ03	LAN	RJ-45	SX03-10905-02
RJ04	LAN	RJ-45	SX03-10905-01
CP07	ALARMS	DB-25 (M)	SX03-10922-01
DJ07	SW DC OUT	2.5 mm Locking DC Power Jack	SX03-10927-01
DJ06	DC POWER IN	Combination Sub-D	SX03-10907-01
DJ01	VSAT IN	F (F), 75 ohm	SX03-10910-02
DJ02	GPS IN	SMA (F), 50 ohm	SX03-10909-03
DJ05	DIV RF2 OUT	N (F), 50 ohm	SX03-10909-01
DJ04	RF HPA FB IN	SMA (F), 50 ohm	SX03-10908-02
DJ03	RF1 OUT	SMA (F), 50 ohm	SX03-10908-01
RJ01	TBD	DB-9	N/A

### 3.9.4 Terrestrial Repeater Monitoring System (TRMS)

During the installation procedure, a number of wires/cables must be connected to the TRMS rear panel. Please refer to [Table 3-8](#) or drawing SX03-10900-03-D06.

The cables should be connected in the order that they appear in [Table 3-8](#).

	<p>Any RF cable, which is terminated with a SMA connector, should be tightened with a 5/16" torque wrench to avoid over tightening and damaging the cable connector or mating connector.</p>
---	--

**Figure 3-28 TRMS Rear Panel**



**Table 3-8 TRMS Rear Panel Connections**

TRMS Port	Name	Type	Cable Number
N/A	N/A	Ground Post	SX03-10926-07
Y1B	RF-IN	SMA (F), 50 ohm	SX03-10908-07
Y2B	RF IN	SMA (F), 50 ohm	SX03-10908-05
Y9B	LAN	RJ-45	SX03-10905-03
Y10A	WAN	RJ-45	SX03-10905-01
Y12	N/A (AC Input)	NEMA Socket Polarized Type IEC 603	SX03-10913-01

### 3.9.5 Dial-up Modem

During the installation procedure, a number of wires/cables must be connected to the dial-up modem (where applicable). Please refer to [Table 3-9](#) or drawing SX03-10900-03-D06.

**Note:** The phone line cord between the Telco surge protector and the dial-up modem is not pre-wired in the DRU. The cable should be connected prior to installing the dial-up modem. Please see Section [3.11.1](#) for details.

**Table 3-9 Dial-up Modem Connections**

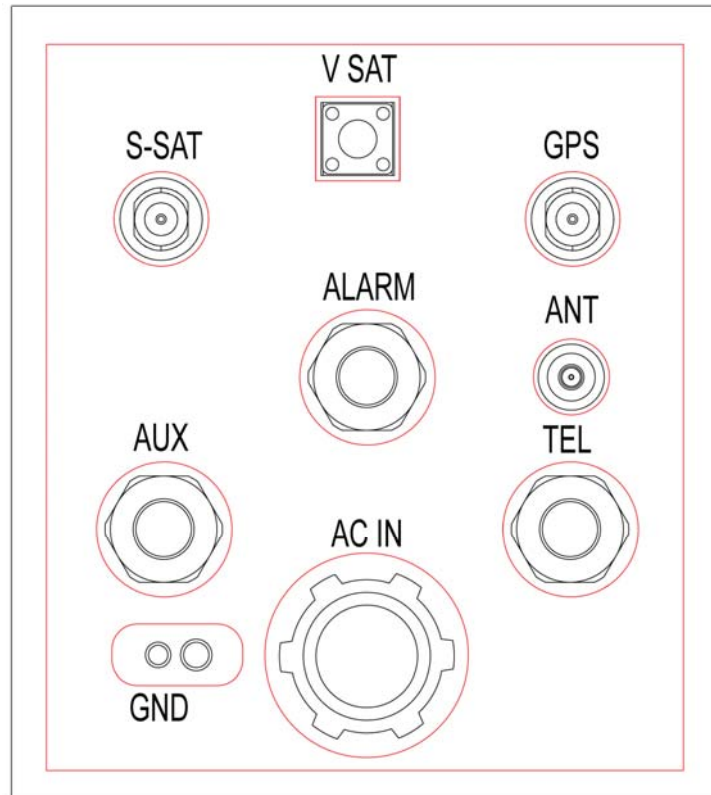
Port	Name	Type	Cable Number
N/A	LINE	RJ-11	N/A
N/A	RS-232	DB-9	N/A
N/A	N/A (DC Input)	2.5 mm Locking DC Power Jack	SX03-10927-01

### 3.10 External Input Signal Interfaces

During the installation procedure, several external input signal connections must be made to the DRU:

- S-Band Antenna (S-SAT)
- Ku-Band VSAT Antenna (V SAT)
- GPS Antenna (GPS)

**Figure 3-29 Repeater Cabinet Cable Entrance**



### 3.10.1 S-Band Antenna

The following steps should be performed to connect the S-Band antenna (HBE RF input) to the DRU:

1. Run a cable from the S-Band antenna to the DRU.
2. If the cable does not already have a male N connector on it, install a male N connector on the end of the cable.
3. Attach and securely tighten the connector to the female N connector marked "S-SAT", which is located on the bottom-left side of the DRU – see [Figure 3-29](#).

### 3.10.2 Ku-Band Antenna

The following steps should be performed to connect the Ku-Band VSAT antenna (LBE RF input) to the DRU:

1. Run a cable from the Ku-Band VSAT antenna to the DRU.
2. If the cable does not already have a male F connector on it, install a male F connector on the end of the cable.
3. Attach and securely tighten the connector to the female F connector marked "V SAT", which is located on the bottom-left side of the DRU – see [Figure 3-29](#).


### 3.10.3 GPS Antenna

The following steps should be performed to connect the GPS antenna (LBE GPS input) to the DRU:

1. Run a cable from the GPS antenna to the DRU.
2. If the cable does not already have a male N-type connector on it, install a male N-type connector on the end of the cable.
3. Attach and securely tighten the connector to the female N-type connector marked "GPS", which is located on the bottom-left side of the DRU – see [Figure 3-29](#).

### 3.11 Communications Interfaces

#### 3.11.1 PSTN Phone Line

	To reduce the risk of fire, use only #26 AWG or larger (I.e. #24 AWG) UL listed phone line cord.
---	--

The following steps should be performed to connect the PSTN phone line to the DRU (where applicable):

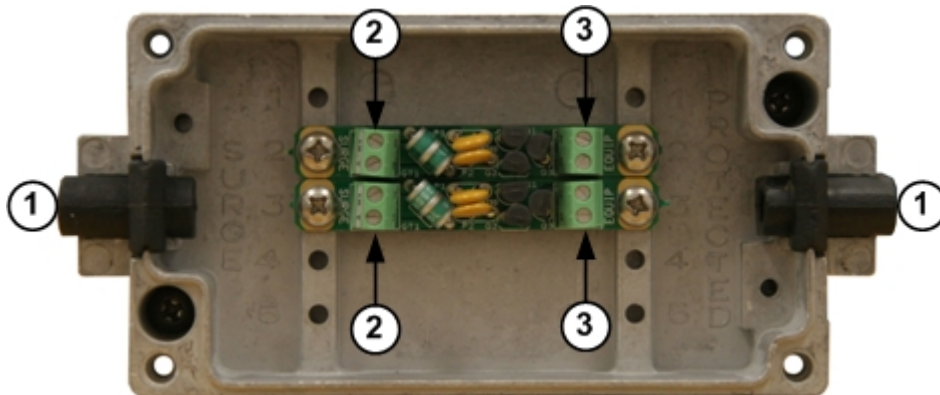
1. Run a #26 AWG or larger phone line cord from the building/site PSTN termination point to the DRU.
2. Loosen the domed sealing nut on the cable gland marked "TEL", which is located on the bottom-left side of the DRU – see [Figure 3-29](#).
3. Feed approximately 24 inches of phone line cord into the DRU through the "TEL" cable gland.
4. Remove the lid screws from the Telco surge protector.
5. Install the cable grommets on the Telco surge protector:
  - Use the small grommet for cord with a 0.114 to 0.225 inch diameter
  - Use the large grommet for cord with a 0.250 to 0,350 inch diameter
6. Feed the phone line cord through the bottom grommet on the Telco surge protector.
7. Cut the cable to the proper length and remove approximately 1 inch of the outer insulation to expose the individual wires.
8. Remove 0.25 inches of insulation from each wire to expose the copper conductor.
9. Insert the copper conductor into the "SURGE" screw terminals on the surge protection modules and tighten the screws.
10. Replace the Telco surge protector lid.

**Figure 3-30 Telco Surge Protector**



- 1) Telco Surge Protector

**Figure 3-31 Telco Surge Protector (open cover)**



- 1) Cable Grommet
- 2) Screw Terminal (Surge Side)
- 3) Screw Terminal (Protected Side)

### 3.12 Shelter/Room Alarm Connections

During the installation procedure, several shelter/room alarm contacts/sensors (where applicable) can be connected to the DRU Break Out Board.

The following steps should be performed to connect an external alarm to the DRU:

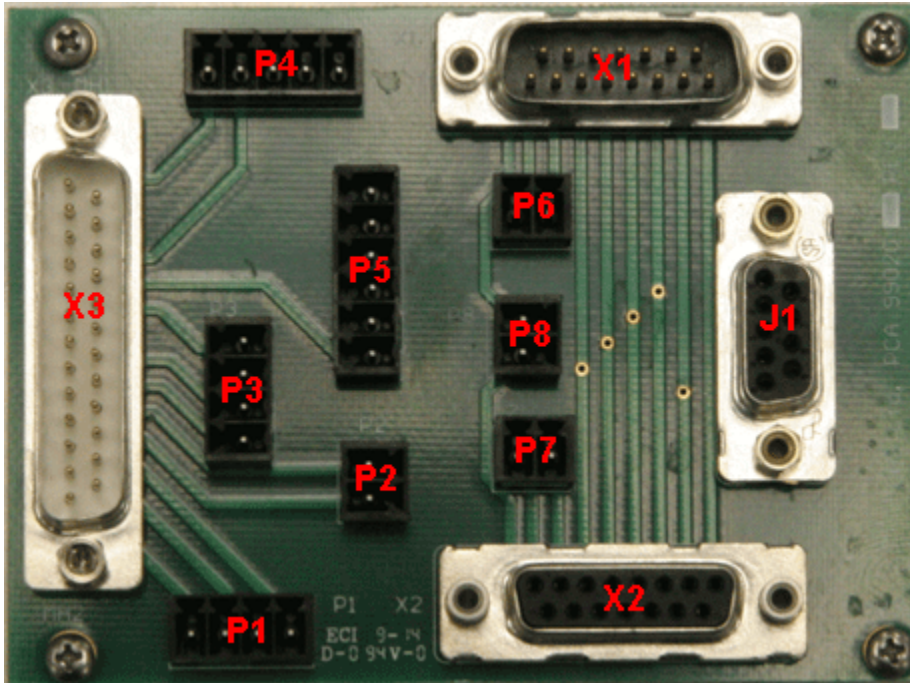
1. Run a cable from the alarm contact/sensor to the DRU.
2. Loosen the domed sealing nut on the cable gland marked "ALARM", which is located on the bottom-left side of the DRU – see [Figure 3-29](#).
3. Feed approximately 72 inches of cable into the DRU and tighten the domed sealing nut on the cable gland.
4. Run the cable along the bottom of the DRU, then up the left wall to the external alarm terminal block – see [Figure 3-32](#).
5. Remove 4 inches of the outer insulation to expose the individual wires.
6. Remove 0.2 inches of insulation from the wires to expose the copper conductors.
7. Insert the wires into the appropriate terminal block contacts and tighten the clamping screws – see [Table 3-10](#) for a list of contacts.

**Figure 3-32 Break Out Board Installed in DRU**





**Figure 3-33 Break Out Board**




**Table 3-10 Break Out Board External Alarm Contacts**

Alarm	Positive (+) Contact	Negative (-) Contact
Low Temp	P1 - 2	P1 - 1 and 3
High Temp	P1 - 4	P1 - 1 and 3
Smoke	P2 - 2	P2 - 1
HVAC1	P3 - 2	P3 - 1 and 3
HVAC2	P3 - 4	P3 - 1 and 3
Blower	P4 - 2	P4 - 1 and 3
Dehydrator	P4 - 4	P4 - 1 and 3
Shelter Door	P5 - 2	P5 - 1 and 3
Spare	P5 - 4	P5 - 1 and 3

**Note:** P4 pin 5 and P5 pin 6 are ground pins.

### 3.13 RF Output Interfaces

	<p>Opening RF lines during operation may cause electric arcs that can cause burns and eye injuries. RF output ports 1 and 2 must be terminated into a broadcast antenna or test load.</p>
---	---

The DRU-200 includes two (2) RF output ports, which are located on the outside of the cabinet above the HPA compartment rear door.

During the installation procedure, these outputs must be terminated into a broadcast antenna or test load.

**Figure 3-34 RF Output Ports**



- 1) Output 1 (Combined RF Output Port) – 7/8" EIA Flange
- 2) Output 2 (Independent RF Output Port) – 7/8" EIA Flange

The HB, LB and LBD transmit signal mapping depends on the DRU configuration – see [Table 3-11](#).

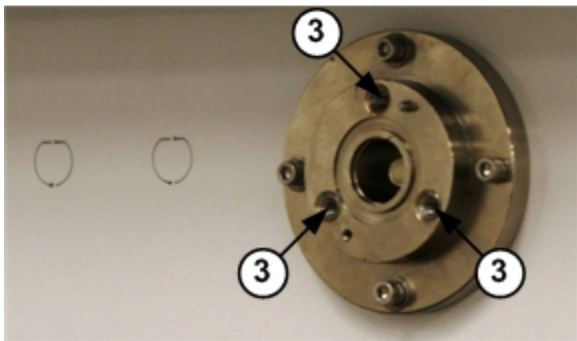
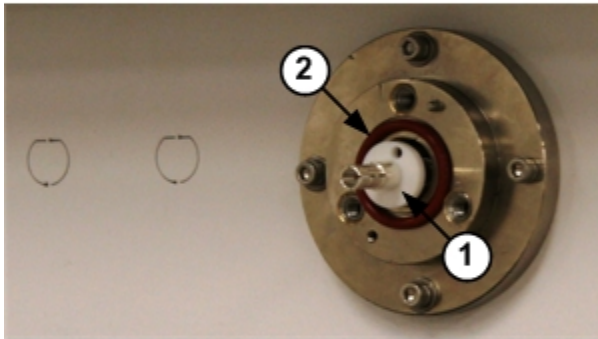
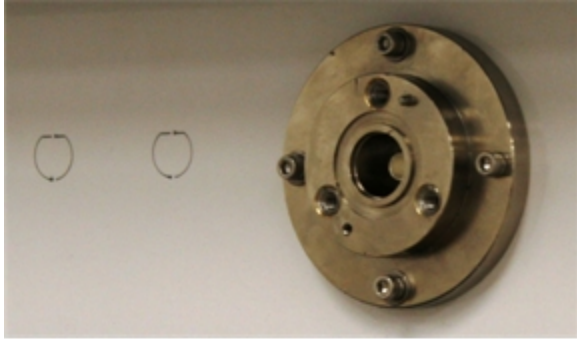
**Table 3-11 RF Output Mapping**

Port	Combined DRU	Independent DRU
Output 1	HB and LB	HB and LBD
Output 2	LBD	LB

The following steps should be performed to terminate Output 1 and Output 2:

1. Insert the inner connector into the 7/8" EIA flange – see [Figure 3-35](#).
2. Place the rubber ring in the 7/8" EIA flange groove – see [Figure 3-35](#).
3. Connect the transmission line (or jumper), with 7/8" EIA flange, to the cabinet according to site drawings.
4. **Secure the transmission line or jumper in place by installing a 1/4-20x1" hex head bolt with 1/4" flat washer and 1/4" spring washer in each one of the holes (3 total) – see [Figure 3-35](#). A 7/16" torque wrench with a rating of 61.5 In. Lbs. should be used to tighten the bolt.**

**Figure 3-35 7/8" EIA Flange Connection (before and after)**




- 1) Inner Connector
- 2) Rubber Ring
- 3) 1/4-20x1" Hex Head Bolt with 1/4" Flat Washer and 1/4" Lock Washer

### 3.14 AC Power


#### 3.14.1 General Requirements

A certified Electrician should connect the repeater to the building/site electrical service panel to meet all local and national electrical codes, and according to the repeater electrical drawing(s).

- AC Supply Voltage: 190 – 264 VAC (208 VAC nominal), Single Phase
- Frequency: 47 to 63 Hz
- Power Consumption: 6.1 kVA max.

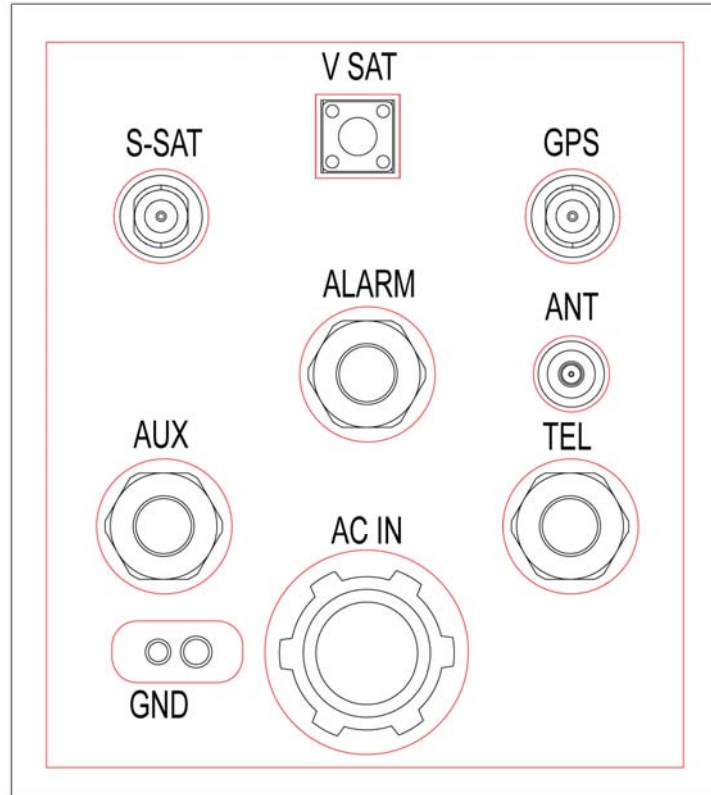
	<p>Verify that the AC supply voltage is within the specified range and check all power cables for damage.</p>
---	---

#### 3.14.2 Repeater Cabinet Ground Connection

	<p>The repeater cabinet must be connected to the building/site's main ground terminal.</p>
---	--

An external ground conductor can be secured to the ground stud located on the left side of the cabinet using the **XX nut** – see [Figure 3-36](#). **A torque rating of XX In. Lbs. should be used to tighten the nut.**

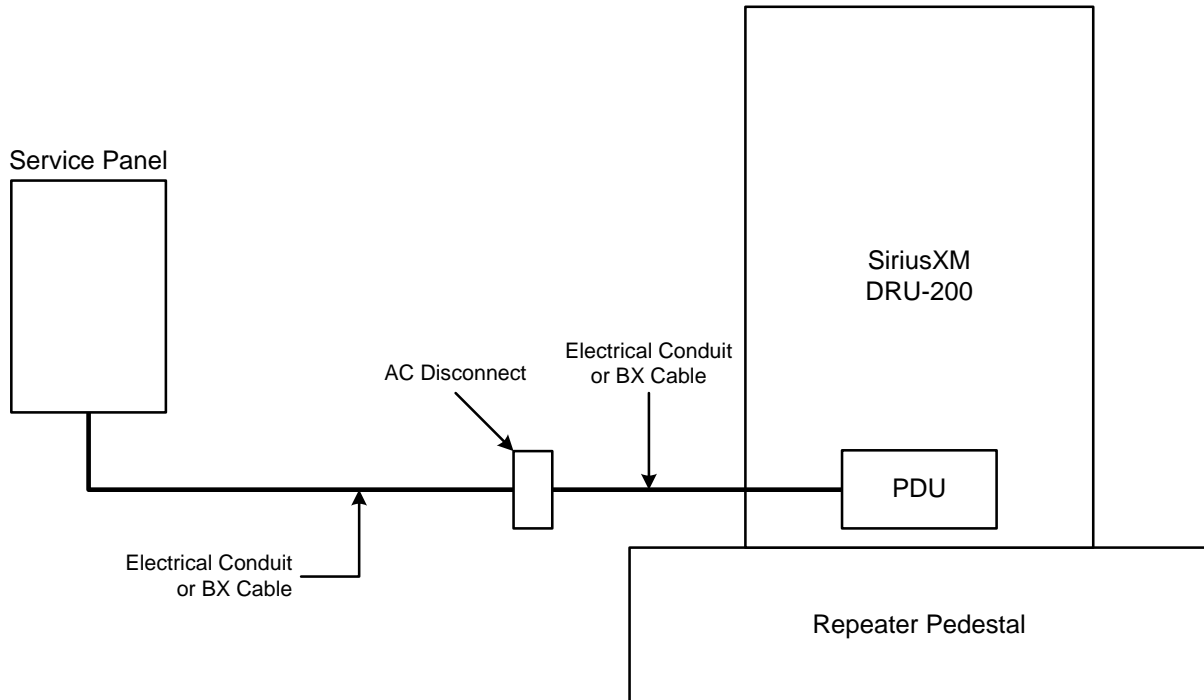
**Figure 3-36 Repeater Cabinet Cable Entrance and Ground Stud**



### 3.14.3 Repeater Cabinet AC Power Connection

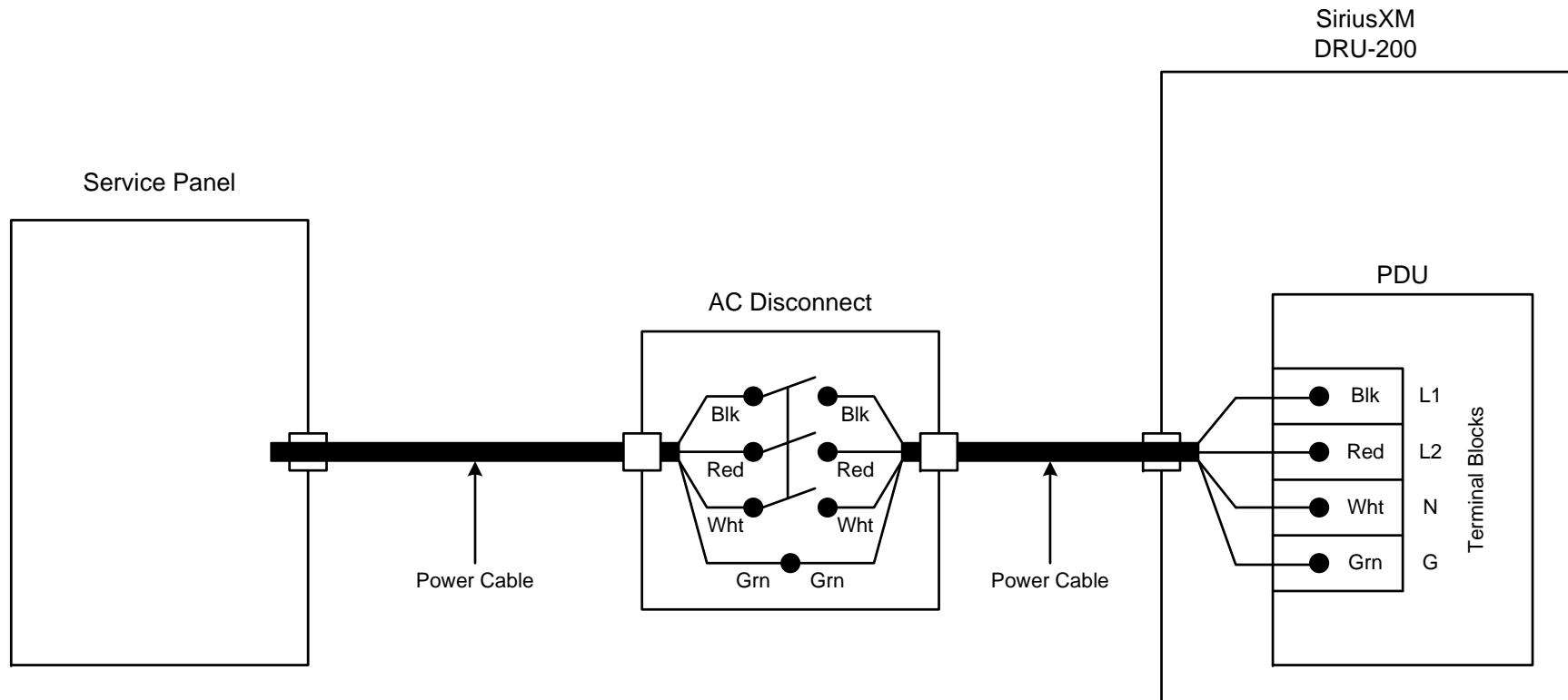
Figure 3-37 depicts the recommended repeater AC power connection.

**Figure 3-37 AC Power Cable Routing**




- Arrange for the installation of an AC disconnect device on the repeater pedestal or in close proximity to the repeater cabinet. The AC disconnect device must be connected to the building/site electrical service panel according to all local and national electrical codes.
- The AC power cable should be run to meet all local and national electrical codes, and according to the repeater electrical drawing(s). This may require the cable to be run inside electrical conduit between the building/site electrical service panel and the repeater cabinet.

Figure 3-38 AC Power Cable Schematic



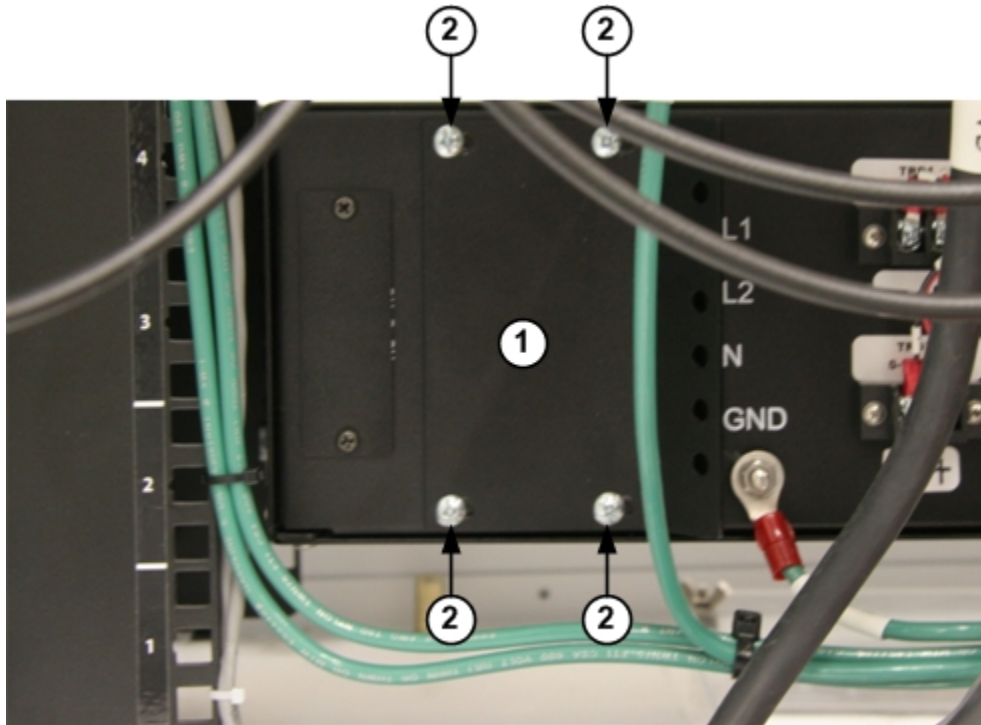
The following steps should be performed to make the electrical connection to the repeater PDU once the power cable has been routed into the cabinet and prepped by a certified electrician:

	Place the circuit breaker in the building/site electrical service panel in the OFF position and place a <b>“DANGER-DO NOT TURN ON - Personnel Working”</b> sign on the circuit breaker.
---	---

1. Remove the terminal block access panel from the back of the PDU by removing the four (4) Phillips head screws – see [Figure 3-39](#).
2. Insert the green wire into the terminal block marked “GND” and tighten the clamping screw – see [Figure 3-40](#).
3. Insert the white wire into the terminal block marked “N” and tighten the clamping screw – see [Figure 3-40](#).
4. Insert the red wire into the terminal block marked “L2” and tighten the clamping screw – see [Figure 3-40](#).
5. Insert the black wire into the terminal block marked “L1” and tighten the clamping screw – see [Figure 3-40](#).
6. Replace the PDU terminal block access panel and verify that all PDU breakers are in the OFF position.
7. Verify that the circuit breaker in the building/site electrical service panel is still in the OFF position and that the AC disconnect device is in the OFF position (where applicable).
8. Place the circuit breaker in the building/site electrical service panel in the ON position and remove the sign.
9. Place the AC disconnect device in the ON position (where applicable).

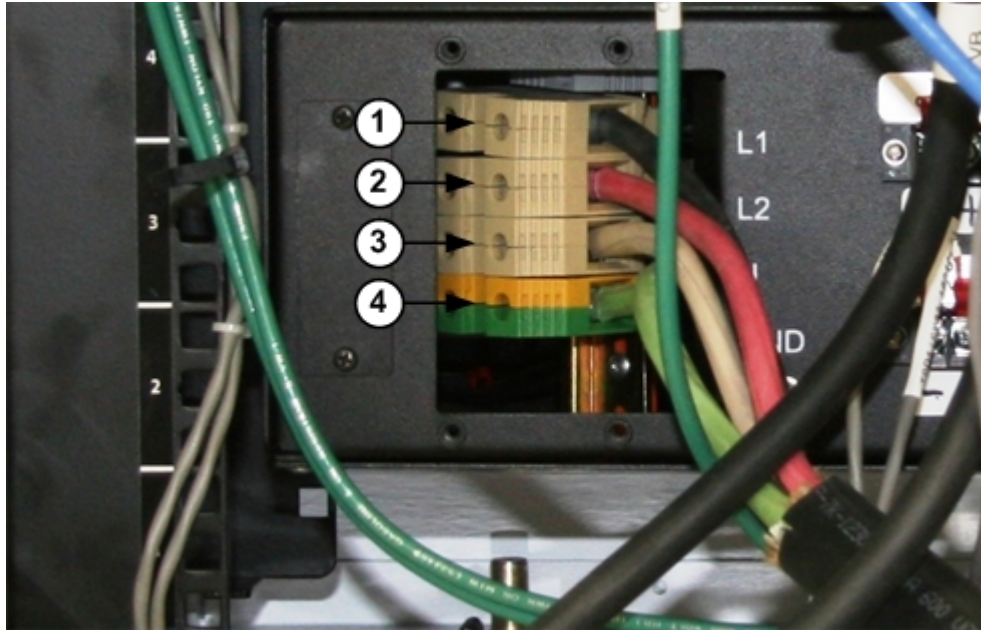


**Figure 3-39 PDU Rear Panel (with access cover installed)**



- 1) Terminal Block Access Panel
- 2) Access Panel Mounting Screws

**Figure 3-40 PDU Rear Panel (with power cable wires installed)**



- 1) Line 1 Terminal Block
- 2) Line 2 Terminal Block
- 3) Neutral Terminal Block
- 4) Ground Terminal Block