

# RS700 Smart RFID Fixed Reader



User's Manual

400682G Version 1.0

## About This Manual

This manual explains how to install, operate and maintain the RS700 Smart RFID Fixed Reader.

No part of this publication may be reproduced or used in any form, or by any electrical or mechanical means, without permission in writing from the manufacturer, which includes but is not limited to photocopying, recording, or information storage and retrieval systems. The material in this manual is subject to change without notice.

© Copyright 2009 Unitech Electronics Co., Ltd. All rights reserved.

Unitech America Web site: <http://www.unitech-adc.com>



Unitech is a member of the Windows Embedded Partner Program.



Unitech is a member of the Oracle Embedded Software Licensing Program.

Microsoft®

**BizTalk Server 2006 R2**

Unitech RFID readers support Microsoft BizTalk Server for data collection.

All product and company names are trademarks, service marks or registered trademarks of their respective owners.

# Regulatory Compliance Statements

---

## Federal Communication Commission Interference Statement

This equipment has been tested and found to comply with the limits for a Class B digital device, pursuant to Part 15 of the FCC Rules. These limits are designed to provide reasonable protection against harmful interference in a residential installation. This equipment generates, uses and can radiate radio frequency energy and, if not installed and used in accordance with the instructions, may cause harmful interference to radio communications. However, there is no guarantee that interference will not occur in a particular installation. If this equipment does cause harmful interference to radio or television reception, which can be determined by turning the equipment off and on, the user is encouraged to try to correct the interference by one of the following measures:

- Relocate the receiving antenna.
- Increase the separation between the equipment and receiver.
- Connect the equipment into an outlet on a circuit that is different from the connected receiver.
- Consult the dealer or an experienced radio/television technician for help.

## FCC Caution:

Any changes or modifications not expressly approved by the party responsible for compliance could void the user's authority to operate this equipment.

This device complies with Part 15 of the FCC Rules. Operation is subject to the following two conditions: (1) This device may not cause harmful interference, and (2) this device must accept any interference received, including interference that may cause undesired operation.

This device and its antenna(s) must not be cohabited or operate in conjunction with any other antenna(s) or transmitter(s).

## FCC Radiation Exposure Statement

This equipment complies with FCC radiation exposure limits set forth for an uncontrolled environment. End users must follow the specific operating instructions for satisfying RF exposure compliance. Please follow the operation instructions in this manual to main compliant with FCC RF exposure compliance requirements. This fixed RFID Terminal meets FCC RF exposure guidelines when used in fixed RFID operation.

## RoHS Statement



This device conforms to RoHS (Reduction Of Hazardous Substances) European Union regulations that set maximum concentration limits on hazardous materials used in electrical and electronic equipment.



## Battery Notices

---

The RS700 is equipped with a Lithium-Ion battery pack. However, the RS700 may not start without an external power source due to battery discharge after extended storage periods. To charge the battery to full capacity, connect the RS700 with the AC Adapter and charge the RS700 for at least 20 hours.

**NOTE:** Press the RS700 Backup Battery Switch before initially using the device.

### Battery charge notice

It is important to consider the environmental temperature whenever the Lithium-Ion battery pack is charged. Charging is most efficient at room temperature or in a slightly cooler environment. It is essential that batteries are charged within the temperature range of **0°C to 50°C (23°F to 122°F)**. Charging batteries outside of this specified temperature range could damage the batteries and shorten their charging life cycle.

## Warranty

---

Unitech limited Warranty covers the following items:

- RS700 Smart RFID Fixed Reader - 1-year limited warranty.
- Please contact a regional Unitech office for further information regarding Unitech's extended warranty package.



# Table of Contents

## Preface

About This Manual	i
<b>Regulatory Compliance Statements</b>	ii
Federal Communication Commission Interference Statement	ii
FCC Caution:	ii
FCC Radiation Exposure Statement	ii
RoHS Statement	ii
<b>Battery Notices</b>	iii
Battery charge notice	iii
<b>Warranty</b>	iii

## Chapter 1

Getting Started	1
<b>Introducing the RS700</b>	1
<b>Features</b>	1
<b>Package Contents</b>	2
<b>A Tour of the RS700</b>	3
Front Panel	3
Top Panel	4
Bottom Panel	4
<b>Connect Power</b>	5

## Chapter 2

Using the Hardware	6
<b>Installing Wi-Fi Antenna</b>	6
<b>Installing RFID Antenna (Optional)</b>	7
<b>Using the GPIO Interface</b>	8
GPIO Pin Assignment	8
<b>Mounting the RS700</b>	9
<b>Performing a Hardware Reset</b>	10

## Chapter 3

Making RFID Applications	11
<b>Using Smart-Reader Server</b>	11
Opening Smart-Reader Server	11
<b>Controlling Smart-Reader Server Remotely</b>	12
Installing Microsoft .NET Framework	12
Installing the SRSRC Program	12
Using the Smart-Reader Server Remote Control	13
Configuring Antenna Port	14
Defining Smart Reader Behavior	15

<i>Creating a New EC Spec</i> .....	16
<i>Specifying Report Criteria</i> .....	17
<i>Setting up Filter Rules</i> .....	18
Defining the EC Spec .....	18
Subscribing the EC Spec.....	19
Redefining the Subscription.....	20
Viewing Data Collection Report .....	21
Viewing Server Log.....	22
<b>Using the Application Programming Interface</b> .....	22
<b>Connecting to BizTalk Server</b> .....	22
<b>Connecting to Oracle Sensor Edge Server</b> .....	30
<b>Chapter 4</b>	
Advanced Settings .....	35
<b>Connecting to a LAN Network</b> .....	35
Obtaining an IP Address.....	35
Setting the System Time.....	36
Setting up Ethernet connection.....	37
<b>Connecting to a WLAN Network</b> .....	38
Managing your Wireless Profiles .....	41
<b>Establishing Terminal-PC Connection</b> .....	44
Installing Microsoft ActiveSync .....	44
Additional Capabilities .....	44
Connecting the terminal to Your Computer .....	45
Using Microsoft ActiveSync to Exchange Files.....	46
<b>Using Remote Control</b> .....	47
<b>Chapter 5</b>	
Troubleshooting .....	48
<b>Appendix A</b>	
System Specification .....	49
<b>Appendix B</b>	
Support .....	50

## Getting Started

### Introducing the RS700

---

Thanks for purchasing the RS700 Smart RFID Fixed Reader. The RS700 is designed for inventory visibility in the warehouse.

The RS700 is a compact, Windows CE 5.0 based stationary data collection terminal with built-in Unitech RFID middleware that provides a Windows-based environment for remote reader control and data filtering functions.

### Features

---

#### Powerful System

- Microsoft Windows CE 5.0 Operating System.
- 520Mhz Intel PXA270 CE CPU.

#### System Memory

- 64 MB SDRAM.
- 64 MB Flash ROM.

#### Power Supply

- External Power: 12V DC, 3A.
- 3800mAh Rechargeable Lithium-Ion Battery.
- Power-over-Ethernet.

#### RFID UHF Reader

- EPCglobal Class1 Gen2 Compliant.
- UHF Frequency: 860 - 960Mhz.
- Built-in RFID Middleware.
- Four Antenna Ports (TNC Connector) and Eight Channels.
- Supports Dense Reader Mode (DRM).

#### Communication

- USB 1.1 Client.
- Serial RS232.
- Ethernet 10/100Base-T.
- IEEE 802.11b/g Wireless LAN, CCX Compatible.
- Relay Outputs (2): Control for Siren and Stacked Lamp.



#### Mounting System

- IP65 Environmental Sealing.
- Operation Temperature: -20°C - 50°C (-4°F - 122°F).
- Storage Temperature: -30°C - 70°C (-22°F - 158°F).
- Uses Din Rail for Wall Mount Installation.

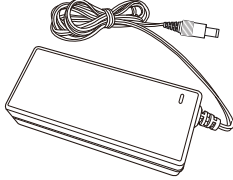
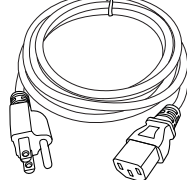
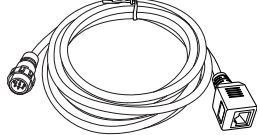
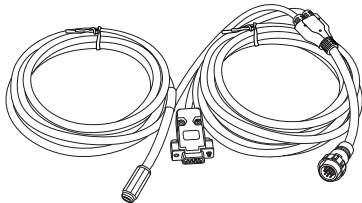
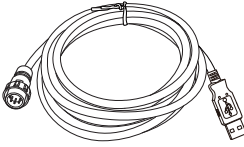
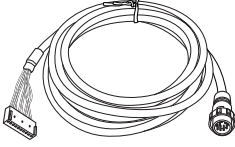
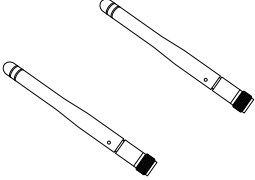

## Package Contents

Please make sure the following contents are in the RS700 box. If anything appears missing or damaged, please contact a Unitech representative.

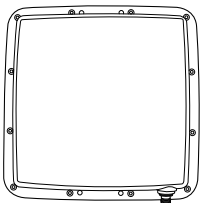
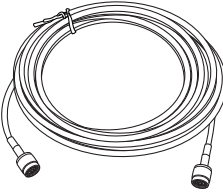
			
<b>Main Unit.</b>	<b>AC Adapter.</b>	<b>Power Cord.</b>	<b>Ethernet Cable.</b>
			
<b>Power/RS232 Cable.</b>	<b>USB Cable.</b>	<b>GPIO Cable.</b>	<b>Two AS103-M-3 Wi-Fi Antennas.</b>
			
<b>Unitech CD-ROM (User Manual, Quick Reference Guide).</b>	<b>Unitech Software Development Kit (Optional).</b>	<b>GPX-026XTPR8-763 RFID Antenna (Optional).</b>	<b>CFD200-NL Antenna Cable (Optional).</b>

## A Tour of the RS700

The following sections describe the main components of the RS700:

### Front Panel

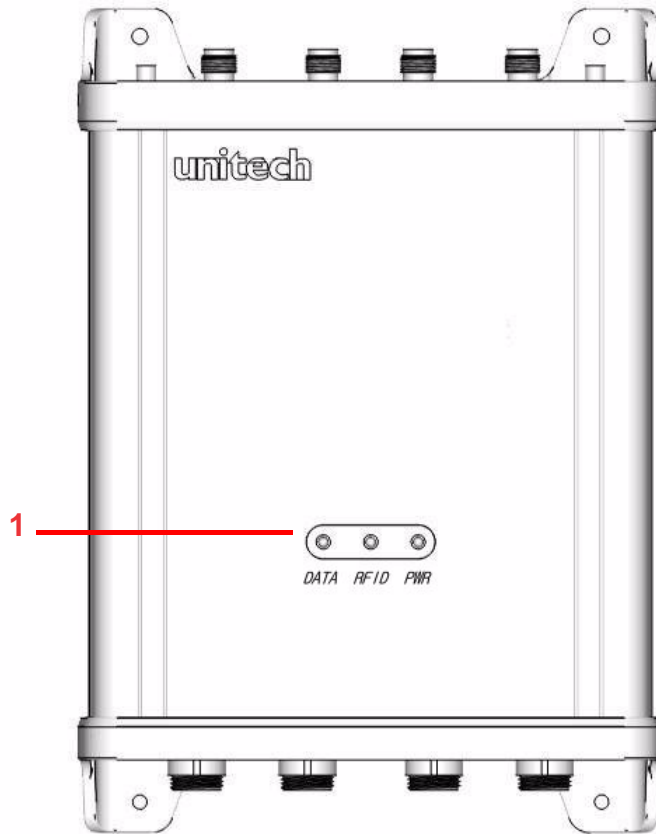

No.	Component	Description
1.	Status Indicators.	Indicates the RS700's terminal operation status (left to right): <b>DATA</b> - Red LED status indicator for data collection. <b>RFID</b> - Yellow LED status indicator for the Smart-Reader Server during normal operation. <b>PWR</b> - Green LED status indicator for receiving external power. (Also dim green LED for receiving Backup Battery power.)

## Top Panel

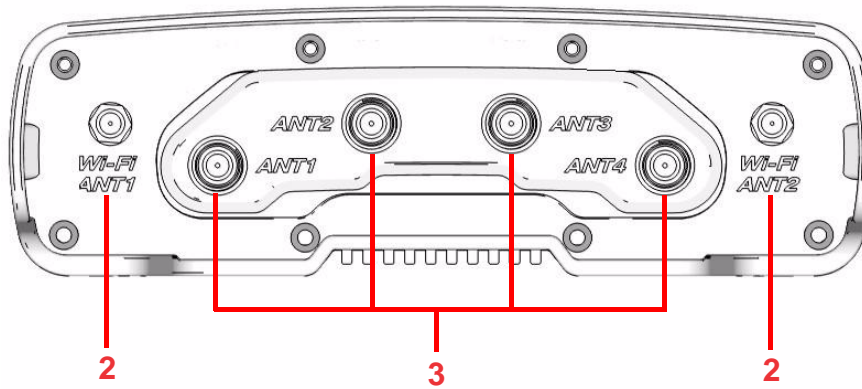

No.	Component	Description
2.	Wi-Fi Antenna Ports.	Wi-Fi ANT1, Wi-Fi ANT2 (left to right), connects the RS700 to Wi-Fi Antennas for wireless signal enhancement.
3.	RFID Antenna Ports.	ANT1, ANT2, ANT3 and ANT4 (left to right) connects the RS700 to RFID Antennas for reading data stored on RFID tags.

## Bottom Panel

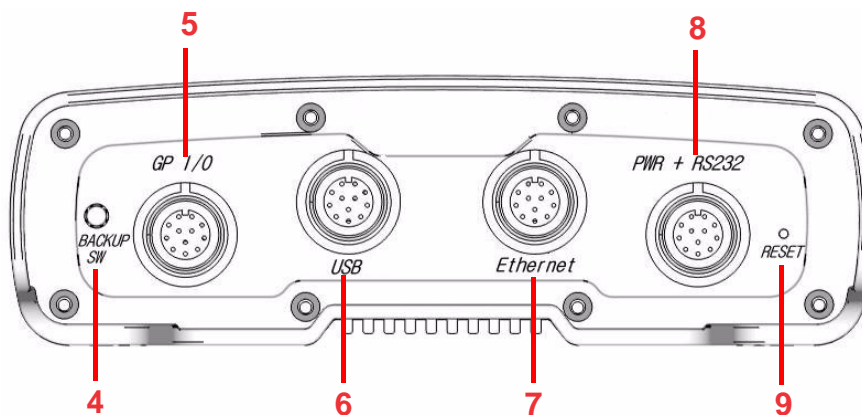

No.	Component	Description
4.	Backup Battery Switch.	Press this switch to engage the Backup Battery.
5.	GPIO Port.	Use the GPIO Cable to connect the RS700 to external controls such as LED indicator lamp, LCD or motion sensor.
6.	USB Port.	Use the USB Cable to connect the RS700 to a host computer and perform Microsoft ActiveSync.
7.	Ethernet Port.	Use the Ethernet Cable to connect the RS700 to a wired Ethernet network.
8.	DC Input Power Port RS232 Port.	Use the Power/RS232 Cable to connect the RS700 to an external power supply or to a computer to perform configuration updates.
9.	Reset Button.	Use a stylus to press the button and reset the RS700.

**CAUTION!** Pressing the Reset Button erases current configuration settings and reboots the RS700.

## Connect Power

An internal backup battery helps prevent data loss when the RS700 disconnects from an external power source. The backup battery stores all data and system settings for up to seven days. Connect power to the RS700 through the following:

**NOTE:** To adequately charge the backup battery, connect the RS700 to an external power source and press the Backup Battery Switch. Charge the RS700 for at least 20 hours. The backup battery begins charging as soon as the RS700 connects to a power source.

1. Connect the Power/RS232 Cable to the PWR + RS232 Port, and rotate the cable cap clockwise to secure the connection.
2. Insert the AC Adapter into the power jack of the Power/RS232 Cable.
3. Insert the Power Cord into the AC Adapter.
4. Plug the other end of the Power Cord into an electrical outlet.

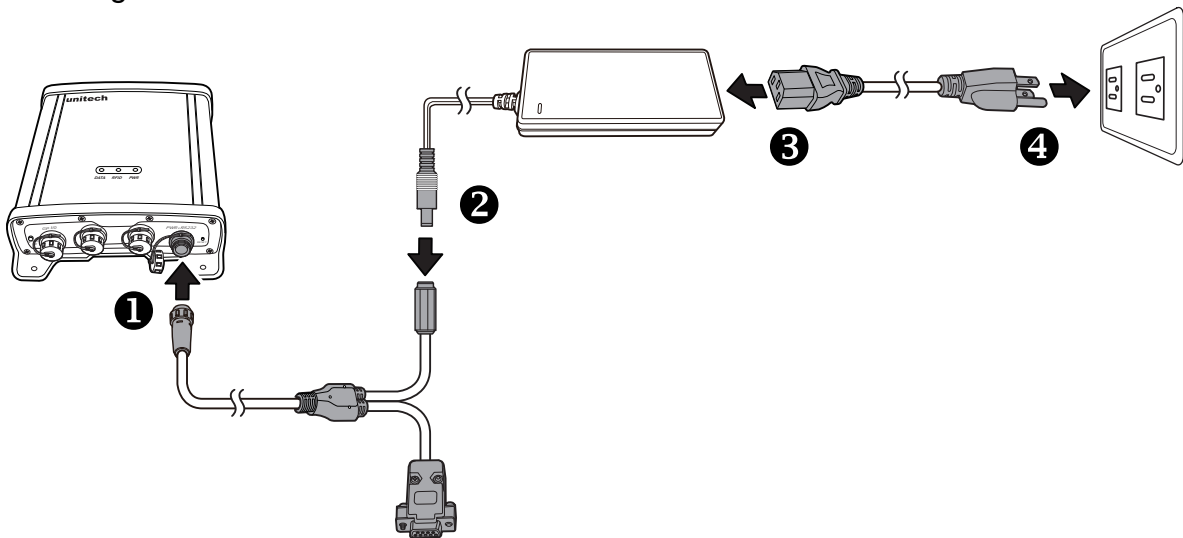

**NOTE:** The PWR LED on the RS700's front panel lights up green when the RS700 connects to a power source.

Once the RS700 connects to an external power source the device is ready for initial setup to make connections and read RFID tags.

# Using the Hardware

The RS700 contains two Antenna Ports for wireless signal enhancement and RFID reading points.

## Installing Wi-Fi Antenna

There are two Wi-Fi Antenna Ports on the RS700 (Wi-Fi ANT1 and Wi-Fi ANT2). Install a Wi-Fi Antenna through the following:

1. Locate the Wi-Fi Antenna Ports on the RS700's top panel.
2. Connect a Wi-Fi Antenna to a desired Wi-Fi Antenna Port, and rotate the antenna cap clockwise to secure the connection.

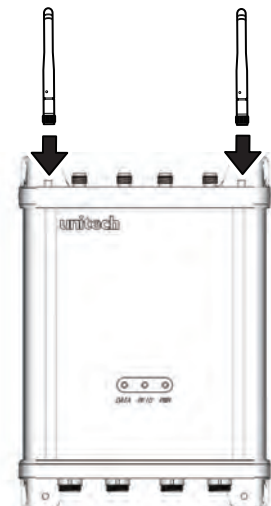

3. Bend the Wi-Fi Antenna(s) to a 90-degree angle.

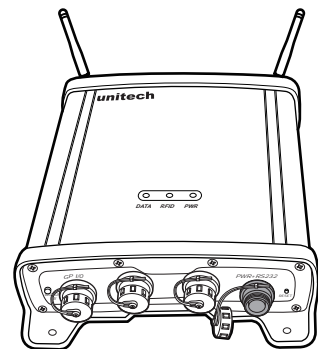

## Installing RFID Antenna (Optional)

The RS700 has four RFID Antenna Ports (ANT1, ANT2, ANT3, and ANT4) and two removable protection caps on ANT2 and ANT3.

**NOTE:** Only remove the protective caps for installing RFID Antennas.

Install an RFID Antenna through the following:

1. Locate the RFID Antenna Ports on the RS700's top panel.
2. If necessary, remove the protection caps on ANT2 and ANT3.
3. Connect the Antenna Cable to the desired RFID Antenna Port, and rotate the cable cap clockwise to secure the connection.
4. Connect the other end of the Antenna Cable to the wall mounted RFID Antenna, and rotate the cable cap clockwise to secure the connection.

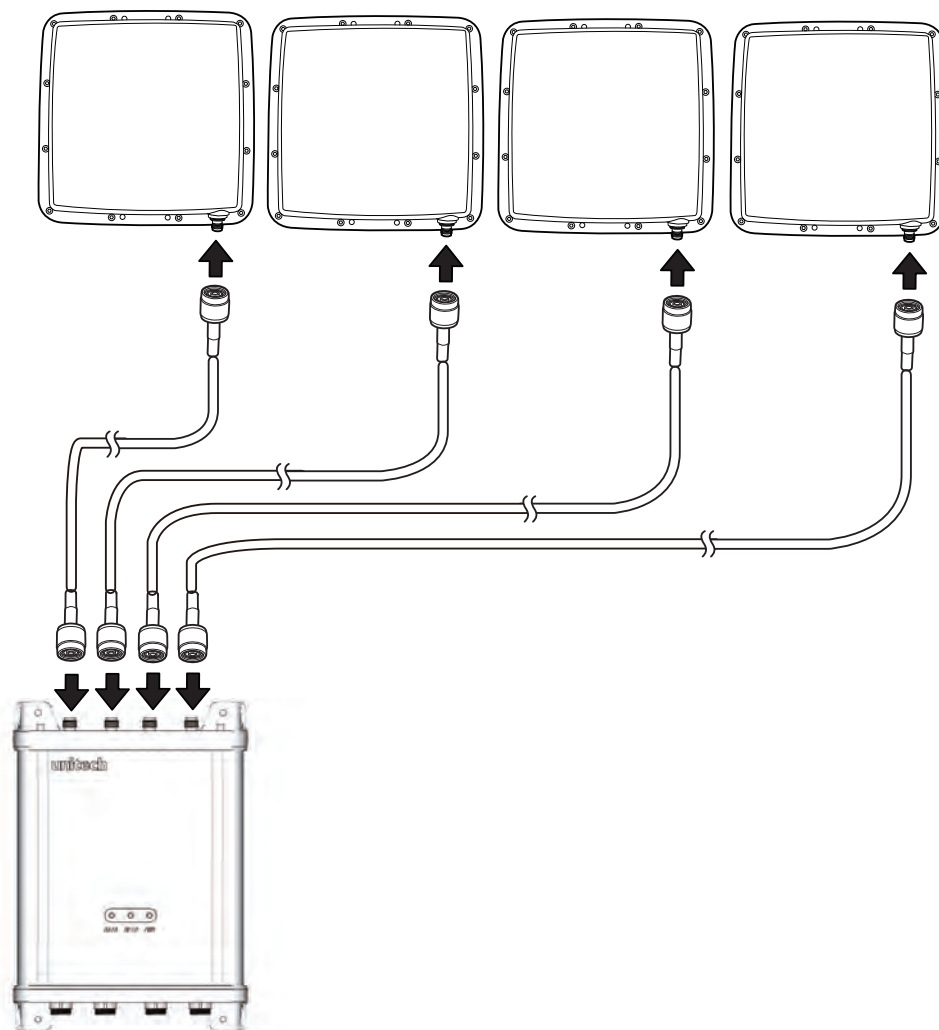

**NOTE:** Refer to the RFID Antenna Installation guide for mounting the RFID Antenna(s).

**WARNING!** To avoid radiation exposure, the RFID Antennas should be installed and operated with minimum distance 1000mm away from the human body.

## Using the GPIO Interface

Use the GPIO Cable to connect the RS700 to several external controls such as an LED indicator lamp, LCD or motion sensor.

### GPIO Pin Assignment

Connect two relay output and digital input signals with the 10-pin GPIO cable. Connect external devices through the following:

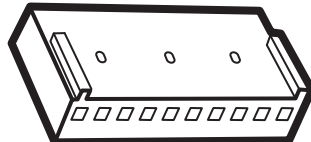

Pin1 ..... 10

Pin	Name	Description
10.	DI1-1.	<p>DIX: Digital Input (X=1; 2).</p> <p>DIX-1: Input Voltage (3.3V - 12V). DIX-2: Ground.</p>
9.	DI1-2.	
8.	DI2-1.	
7.	DI2-2.	
6.	RL1C.	<p>RLX: Relay (X=1; 2).</p> <p>C: Common. NC: Normal Close. NO: Normal Open.</p>
5.	RL1NC.	
4.	RL1NO.	
3.	RL2C.	
2.	RL2NC.	
1.	RL2NO.	

## Mounting the RS700

The RS700 comes standard with a wall mounting kit for easy installation.

Mount the RS700 to a wall through the following:

- Plastic conical anchor (4) 3x25mm.
- Self-tapping screw (4) 3.5x19mm.

1. Locate the four mounting holes on the RS700.

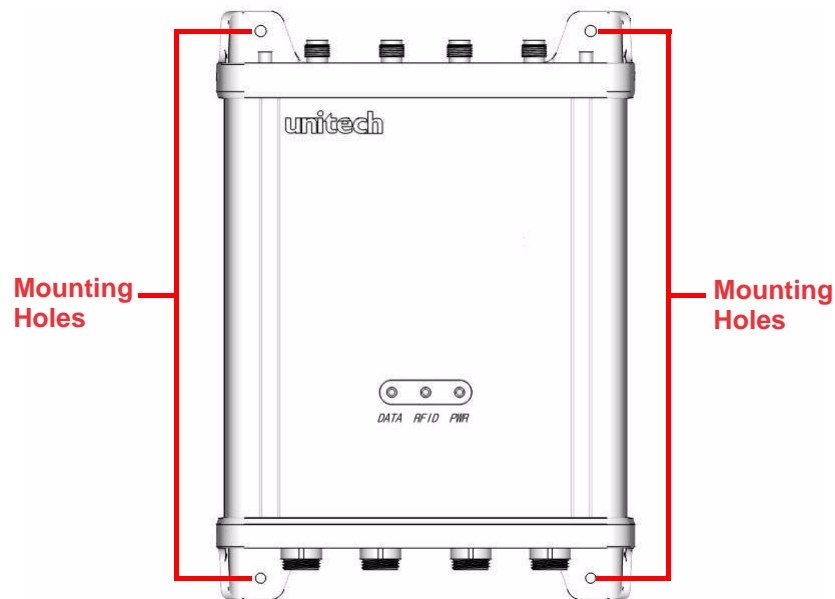

2. Place the RS700 on the wall. Mark the mounting hole locations with a pen.
3. Remove the RS700 and drill four 1/4-inch wide holes at least one inch deep.
4. Insert the four plastic conical anchors into the holes.
5. Secure the RS700 to the wall with the four self-tapping screws, and insert them into the plastic conical anchors.

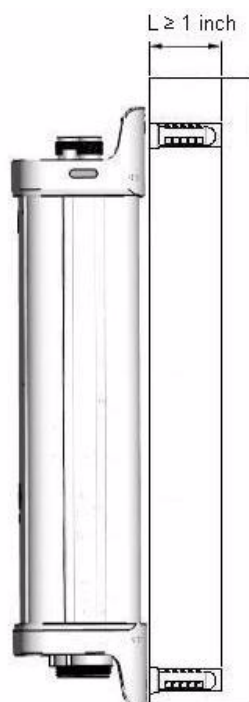



## Performing a Hardware Reset

---

Perform a reset if the RS700 freezes (i.e., no longer responds).

Resetting the RS700 erases all installed records, entries and programs; returning the RS700 to default status. (Not even the date and time settings remain.) All settings return to default mode. However, data stored in the flash storage or in an SD Card Slot will remain intact. Use the remote control to access the SD folder on the RS700. See *Using Remote Control* on page 47.

**NOTE:** During the next Microsoft ActiveSync operation, lost data can be restored that was previously synchronized on the computer, or data can be restored from a storage card.

Reset the RS700 through one of the following:

1. Use a stylus to press the reset button on the RS700's bottom panel.
2. Reconnect the power supply, and reset the Backup Battery Switch to the **on** position.

**CAUTION!** Pressing the Reset Button erases current configuration settings and reboots the RS700. The RS700 returns to default mode. All registry settings and all files (including hidden files) are returned to their original factory defaults.

# Making RFID Applications

The Unitech RS700 Smart RFID Fixed Reader can do more than just read, store or forward data. The built-in Unitech RFID middleware helps filter data, execute commands and perform rich functions at the front end.

The Smart-Reader Server is designed to control and collect data from RFID tags through a wired or Wi-Fi network. Enhancing the data precision is possible by creating accurate reports, reducing server load and even customizing RFID applications on the RS700.

## Using Smart-Reader Server

### Opening Smart-Reader Server

The RS700 automatically starts once it connects to an external power source. Follow the instructions below to check which programs are currently active (If necessary, activate the Smart-Reader Server on the RS700).

1. Install the remote control program. See *Using Remote Control* on page 47.
2. On the remote control window, double click **My Device** → **Windows** → **SRS** → **SmartReader Server**. The SRS window appears with an assigned IP address.

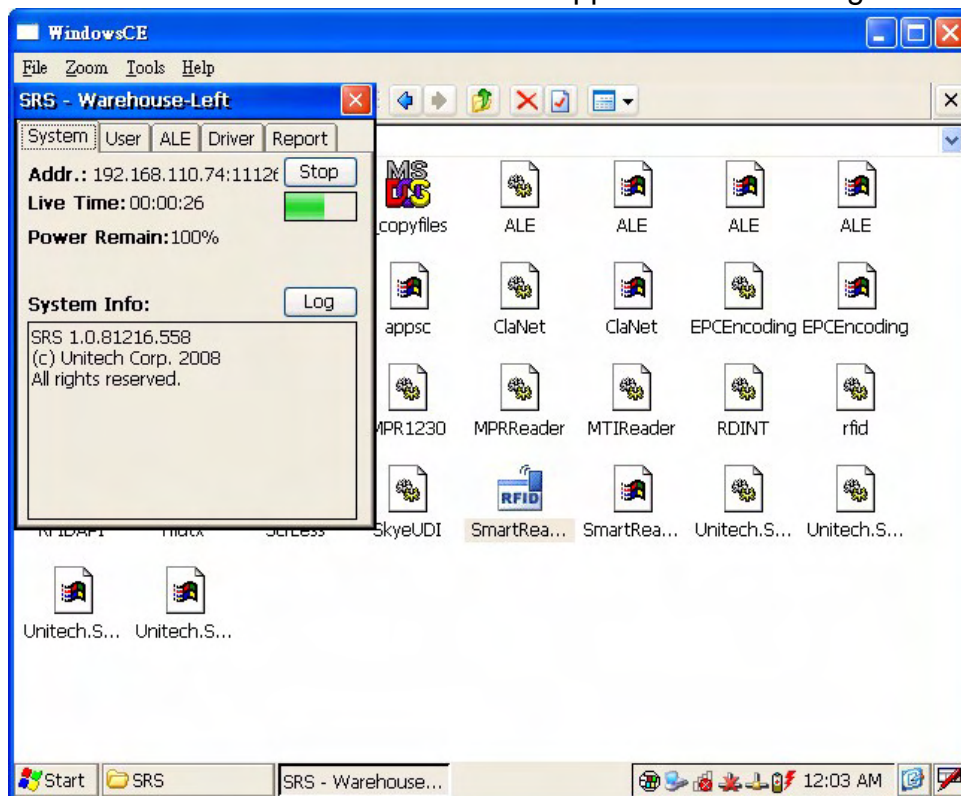

**NOTE:** The yellow RFID LED flashes on the RS700's front panel, indicating that the Smart-Reader Server is operating.

### Controlling Smart-Reader Server Remotely

It is necessary to install the Smart-Reader Server Remote Control (SRSRC) Program, to control the built-in RS700 Smart-Reader Server remotely. Please contact a Unitech representative to acquire the program.

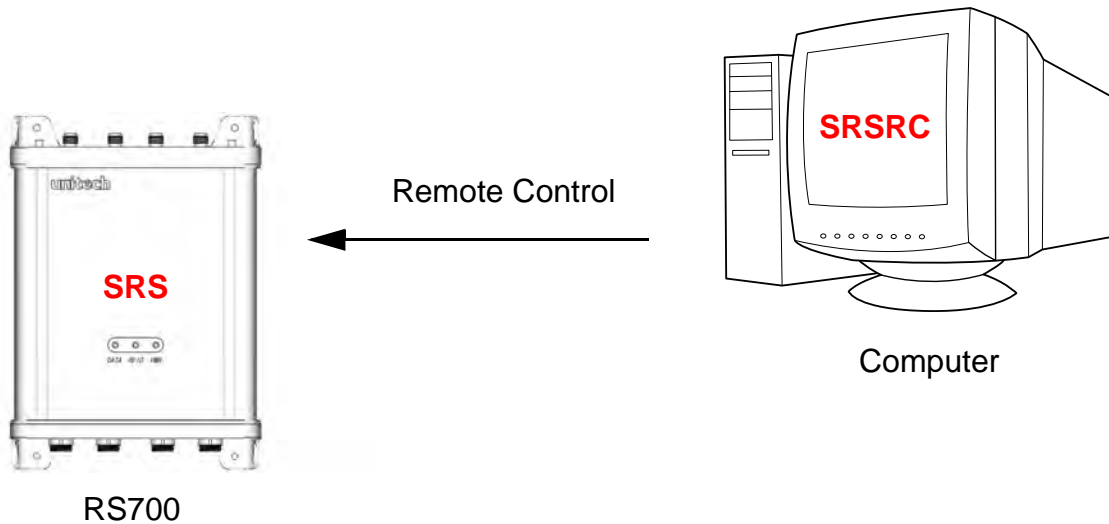

#### Installing Microsoft .NET Framework

To execute the SRSRC, Microsoft .NET Framework 3.5 must be installed on the computer. Download the software from the Microsoft Download Center at:

<http://www.microsoft.com/downloads/details.aspx?FamilyID=333325fd-ae52-4e35-b531-508d977d32a6&DisplayLang=en>.

**NOTE:** Uninstall any previous versions of Microsoft .NET Framework before installing Microsoft .NET Framework 3.5.

#### Installing the SRSRC Program

Install the SRSRC program and acquire an IP address for the RS700 through the following:

1. Connect the computer to a DHCP enabled network.
2. Connect the Ethernet Cable to the Ethernet Port on the RS700's bottom panel, and rotate the cable cap clockwise to secure the connection.
3. Connect the RS700 to the same network via DHCP. The DHCP server will assign an IP address to the RS700.
4. Install SRSRC.msi on the computer.
5. Follow the onscreen instructions to complete the installation of the SRSRC program.
6. Click **Start** → **Programs** → **Smart-Reader Server Remote Control** → **Reader Discovery**.

- Click **Discovery** to lookup the DHCP client in the same subnet.

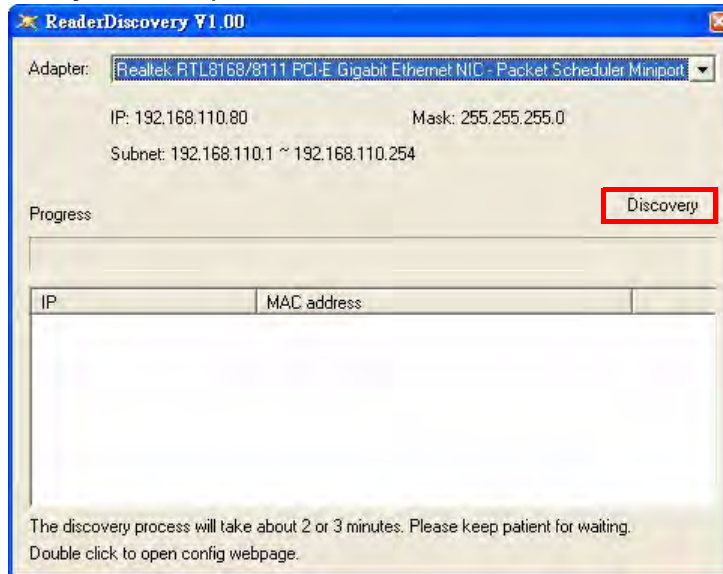

- Refer to the MAC address label attached on the RS700's bottom panel, and discover the RS700's IP address from the list box.

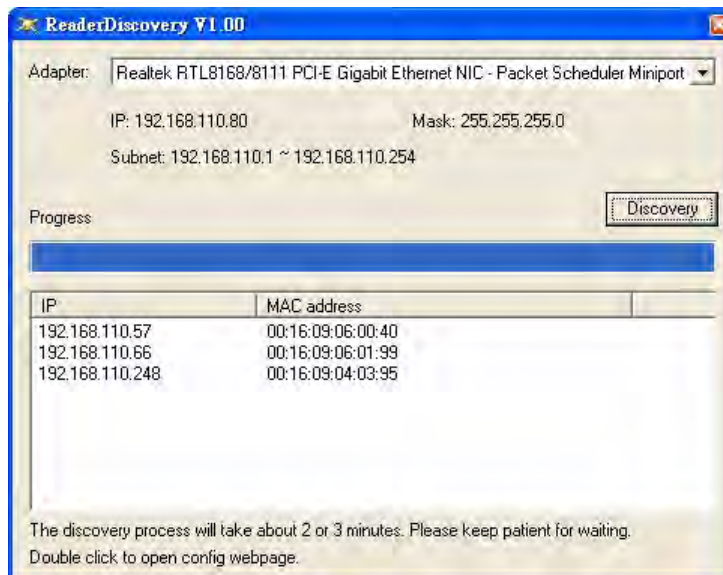

## Using the Smart-Reader Server Remote Control

Start using the SRSRC through the following:

- Click **Start** → **Programs** → **Smart-Reader Server Remote Control** → **Smart-Reader Server Remote Control**.
- Enter the assigned IP address in the **Server Address** field. To login, enter the default user name and password as **unitech**. Click **OK**.

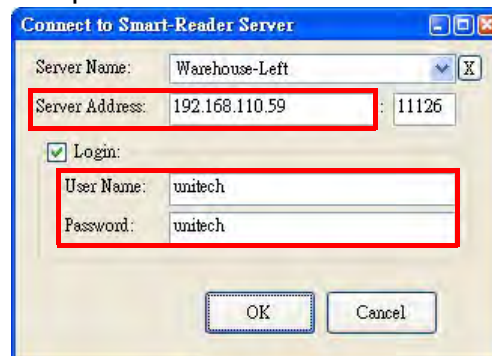

**NOTE:** Do not change the default port number from **11126**, and ensure that the port is not occupied by any other service.

- The SRS Remote Control window appears. The SRSRC menu resides in the left pane, while the reader status is in the right pane. At the bottom right corner of the screen, the login info displays the user name and the login time duration. Click **Stop** to end the connection between the RS700 and the R1000 Reader.

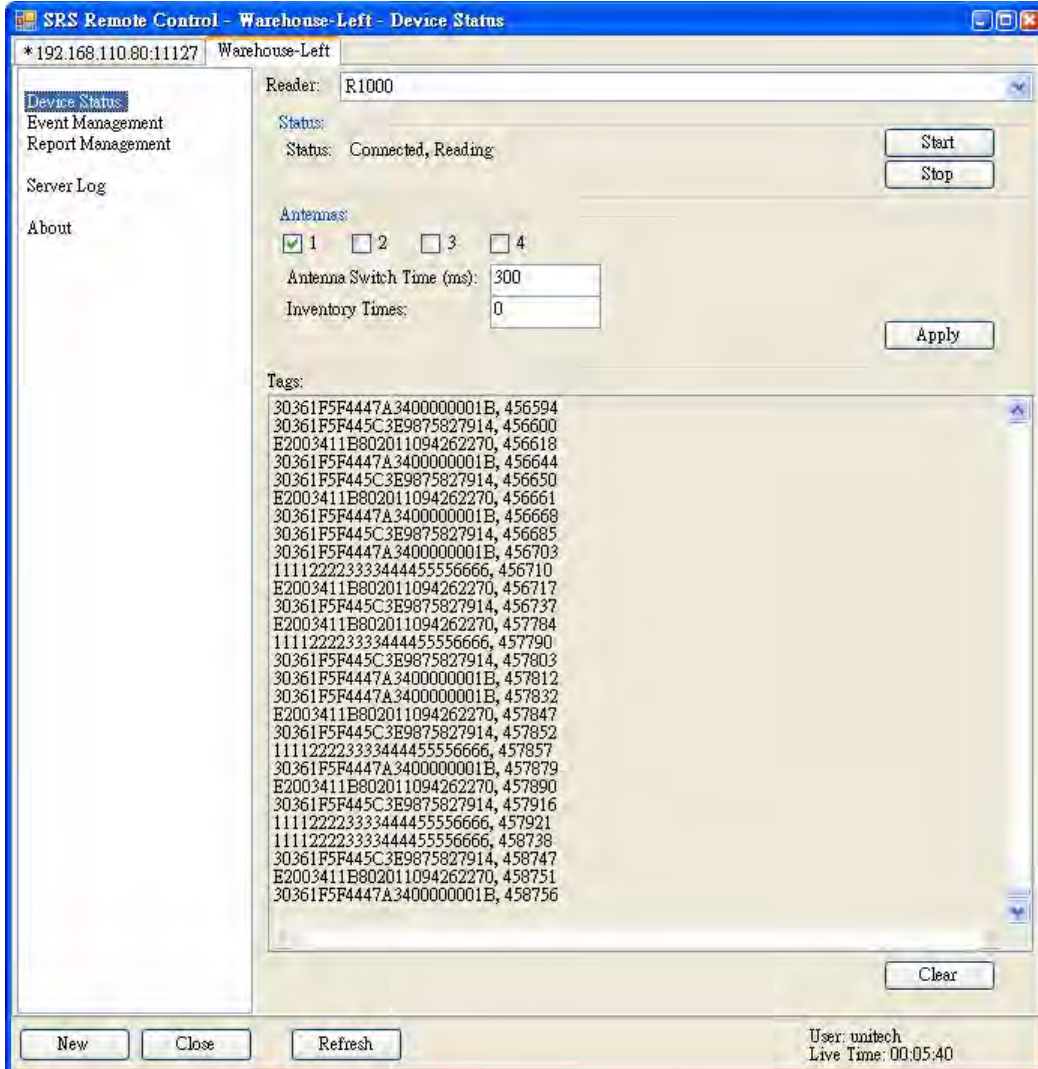

**NOTE:** A dialog box appears informing **User account expired!** (when the screen is idle for three minutes). Login (again) and continue with the settings.

### Configuring Antenna Port

To enable or disable antennas connected to antenna ports, click **Device Status** in the left screen panel. Configure the Antenna Port settings through the following:

- In the **Antennas:** field, check the antenna port number to enable the antenna. Antenna port number (**1** is checked by default). If more than one antenna is enabled, the antennas switch in numerical order (i.e., 1 → 2 → 3 → 4 → 1).
- In the **Antenna Switch Time (ms):** field, input the Antenna Switch Time for each reading period (**300ms** by default).

- In the **Inventory Times:** field, input the Inventory Times for reading times within the reading period (**0ms** by default). A setting of 0 or 8192ms is recommended, but it depends on the local environment.

NOTE: The Antenna Switch Time and the Inventory Times cannot both be simultaneously set at **0**.

- Click **Apply** to save the settings.

Antenna ports switch when the Antenna Switch Time or Inventory Times run out. If installed properly, the Tags screen will display any data collected from the antennas. Click **Clear** at the bottom of the screen to view the fresh data. See *Installing RFID Antenna (Optional)* on page 7.

NOTE: The red DATA LED flashes on the RS700's front panel, indicating data collection.

## Defining Smart Reader Behavior

In the left pane, click **Event Management**. In the right panel, define the event cycle specifications, specify the report criteria and the setup filter rules.

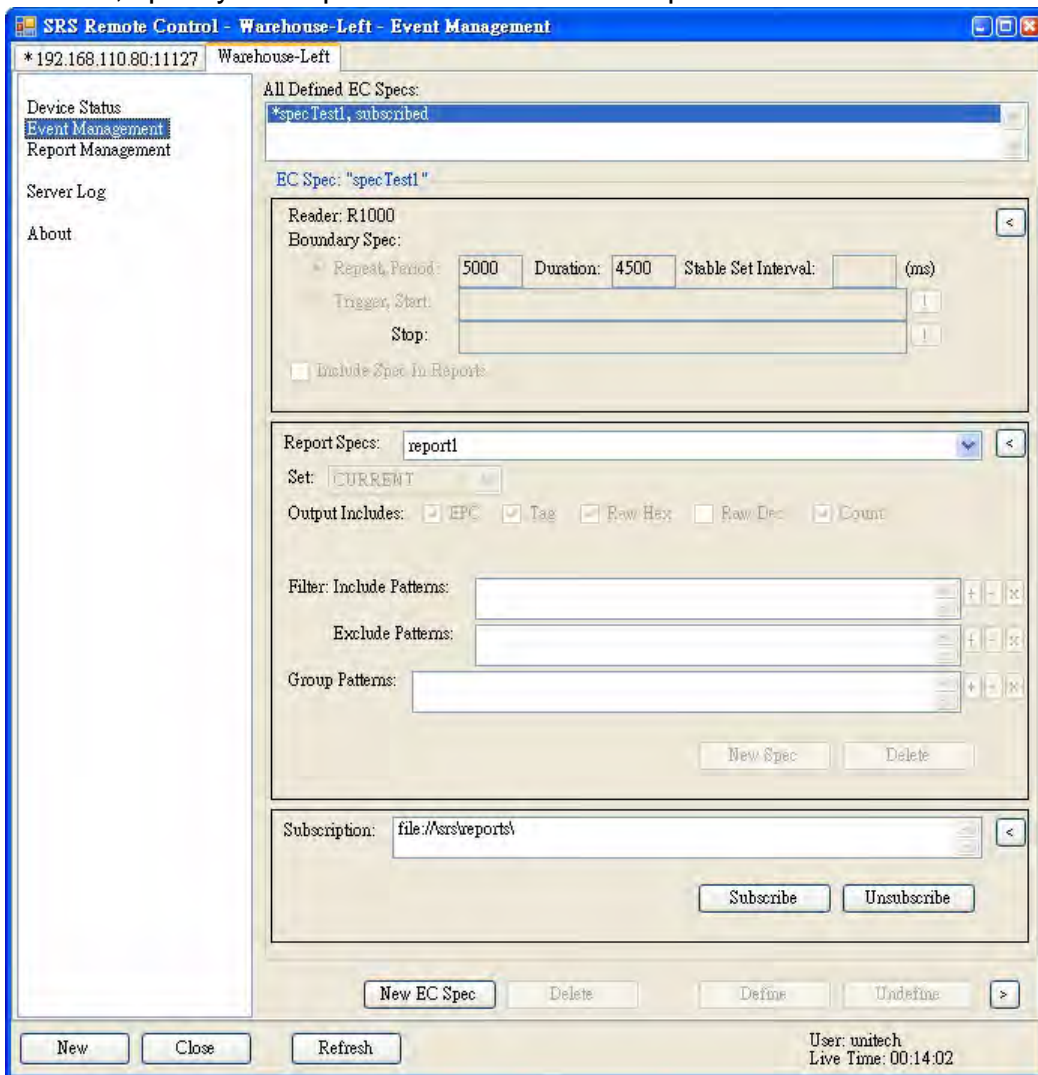

### Creating a New EC Spec

In the **All Defined EC Specs** field, **\*specTest1** is defined and subscribed as the default. Create a new event cycle specification through the following:

1. Click **New EC Spec**. An InputBox screen appears.

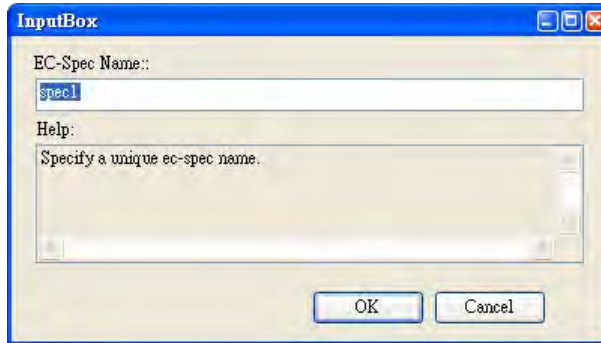

2. Input a unique EC Spec name or accept the default at **spec1**. Click **OK**, and **spec1** appears in the **All Defined EC Specs** field.

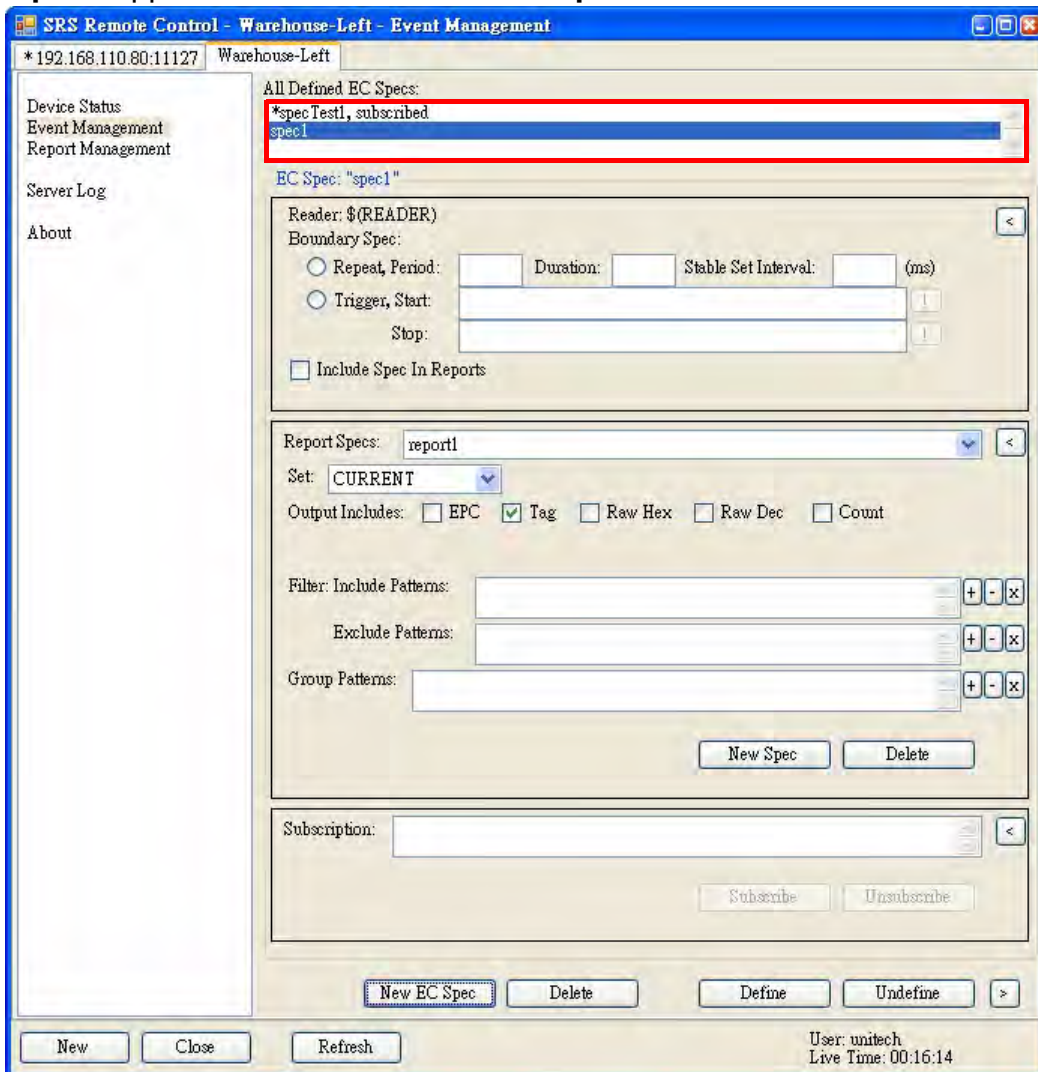

3. In the **All Defined EC Specs:** field, check **Repeat, Period:** for the automatic reading mode, and set the following values in milliseconds.
  - **Repeat, Period:** field - Cycle time (**5000ms** by default).
  - **Duration:** field - Duration for reading data within the cycle time (**4500ms** by default).

- **Stable Set Interval:** field - Interval time between cycles (**0ms** by default).
- 4. Check **Trigger, Start:** to activate the trigger manually. Specify the **trigger start/stop** name for the event cycle. Add **//** before the name string. For example, input the following in each field:
  - Start: **//spec1\_start\_trigger**.
  - Stop: **//spec1\_stop\_trigger**.
- 5. Check **Include Spec In Reports** to include the EC-Spec info in the report.

### Specifying Report Criteria

In the **Report Specs** field, set **report1** as the default. Modify or create reports through the following:

1. Click **New Spec** and **Yes** to create a new report. The **report2** appears in the **Report Specs** field. Click **Delete** to delete a selected report.

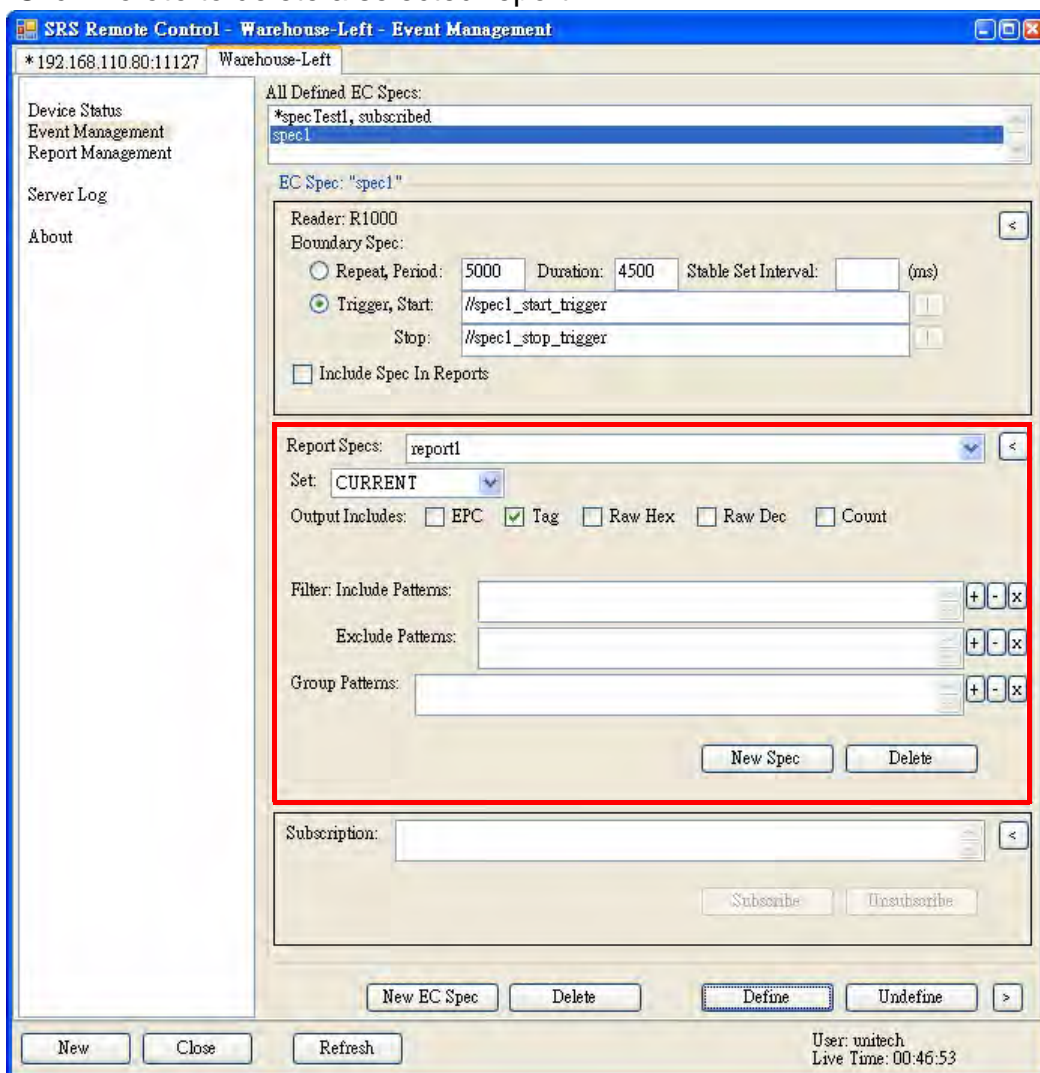

2. In the **Set:** drop down menu, select the occasion for the report:
  - **CURRENT:** Produces report when tag reading occurs.
  - **ADDITIONS:** Produces report when tag seen in this cycle, but not in the previous cycle.
  - **DELETIONS:** Produces report when tags not seen in this cycle, but seen in the previous cycle.



3. Definitions of the options in the **Output Includes** field:
  - **EPC:** Displays EPC encoding method.
  - **Tag:** Displays tag ID.
  - **Raw Hex:** Displays hexadecimal data.
  - **Raw Dec:** Displays decimal data.
  - **Count:** Displays tag count.

### Setting up Filter Rules

Use a filter to sort data in the **Report Specs** field. Setup the filter rules through the following:

1. To add a filter, select a desired report from the **Report Specs** drop down menu. For example, **report1**.
2. To add a new inclusive pattern, click **+** next to the **Include Patterns** field. An InputBox screen appears with some predefined patterns for reference.

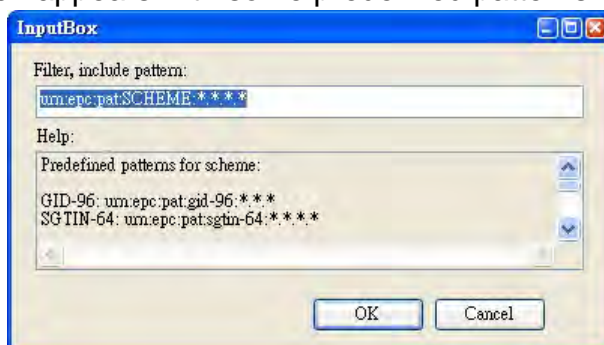

To create a GID-96 encoding, input any of the following:

- **urn:epc:pat:gid-96:20.100.5000** to match the EPC for Unitech serial number 5000.
  - **urn:epc:pat:gid-96:20.100.\*** to match any ABC's EPC (regardless of serial number).
  - **urn:epc:pat:gid-96:20.\*.[5000-9999]** to match any XYZ Corporation product whose serial number is between 5000 and 9999 (inclusive).
  - **urn:epc:pat:gid-96:\*.\*. \*** to match any GID-96 tag.
3. Click **OK** to confirm.
    - To modify an inclusive pattern, select the pattern and click **-**.
    - To delete an inclusive pattern, select the pattern and click **x**.
  4. Follow similar steps to exclude or group patterns.

### Defining the EC Spec

After defining the event cycle and its report specifications, save this EC Spec through the following:

1. Select a desired EC Spec, for example, **spec1**.
2. Click **Define**. The **#spec1, defined** appears in the **All Defined EC Specs** field.

## Subscribing the EC Spec

In order to implement the event cycle, make a subscription to the EC Spec through the following:

1. Select a defined EC Spec in the **All Defined EC Specs:** field. For example, **#spec1**.
2. Click **Subscribe**. An InputBox screen appears with some predefined formats for reference.

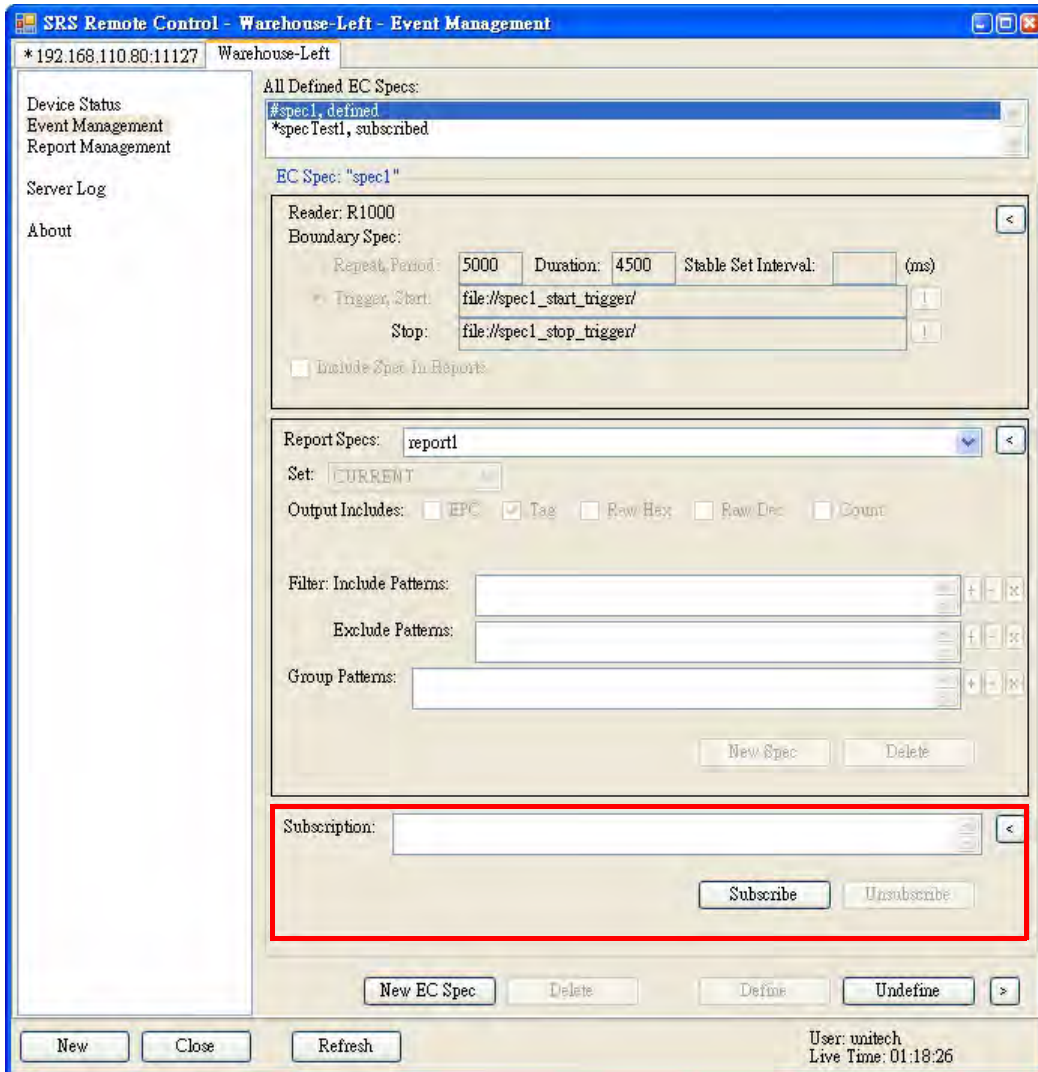

3. In the **Subscribe Notification:** field, input any of the following:

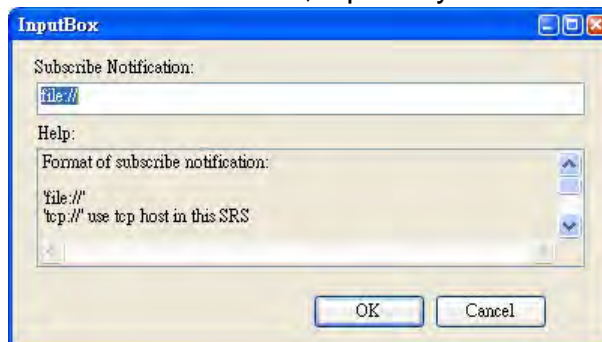

- **file://** to store data in the folder located in the path My Device/srs/reports on the RS700.

- **tcp://** to send the report to the computer hosting SRS, i.e., **192.168.110.80:11127**, the tab shown on the upper left corner of the screen.
  - **tcp://192.168.110.114:11126** to send the report to another computer in the same subnet with IP address **192.168.110.114** and default port **11127**.
4. Click **OK**, and **\*spec1, subscribed** appears in the **All Defined EC Specs** field. Click the **!** button next to the trigger start/stop fields that appear, and this allows to control the reading behaviors.

### Redefining the Subscription

Redefine a subscribed EC Spec through the following:

1. In the **All Defined EC Specs:** field, select a subscribed EC Spec. For example, **\*spec1**.
2. In the **Subscription:** field, select the subscribe notification path.
3. Click **Unsubscribe** to cancel the subscription.

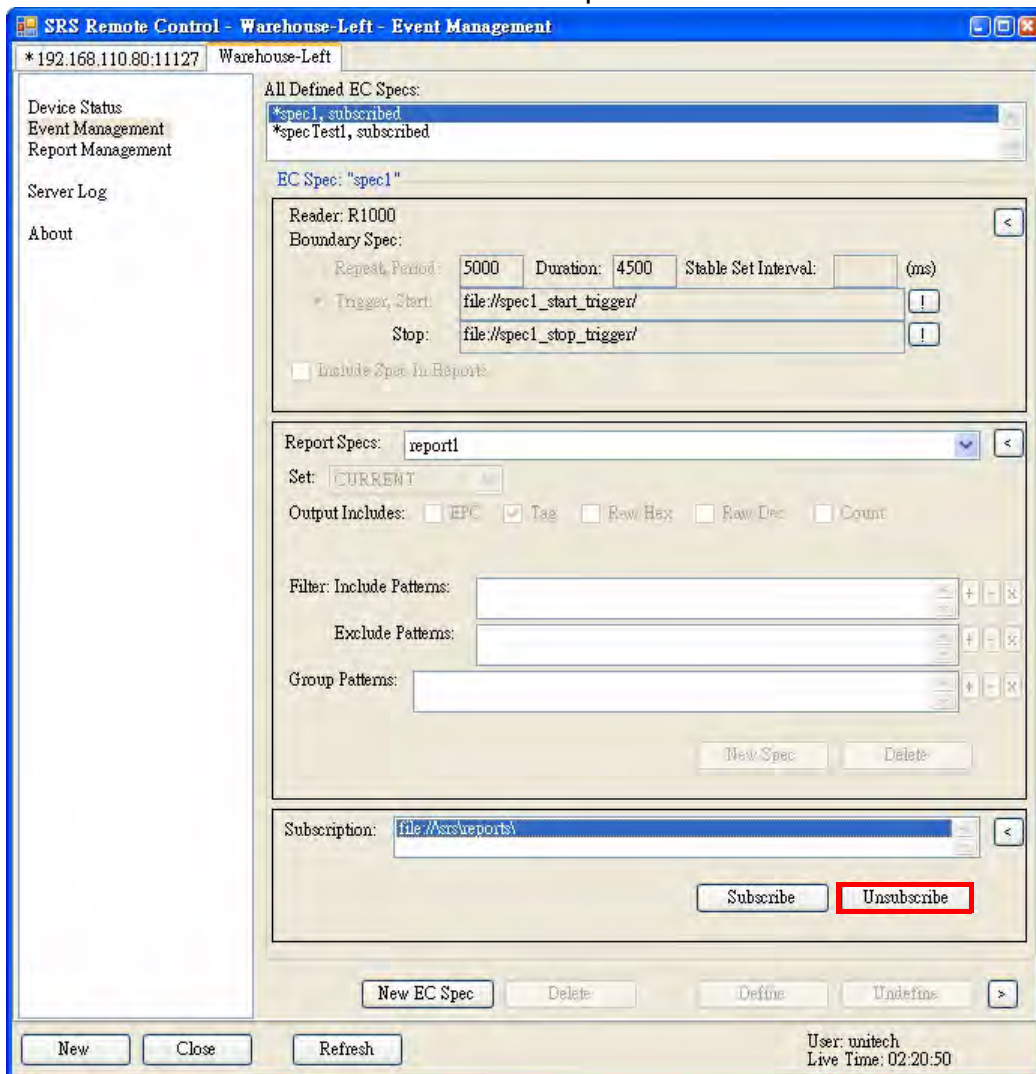

4. Click **Undefine** or **Delete** at the bottom of the screen. Now, it is possible to redefine or delete this EC Spec.

## Viewing Data Collection Report

Click **Report Management** in the left screen panel. All reports set to store on the RS700 will display in the right pane. Manage reports through the following:

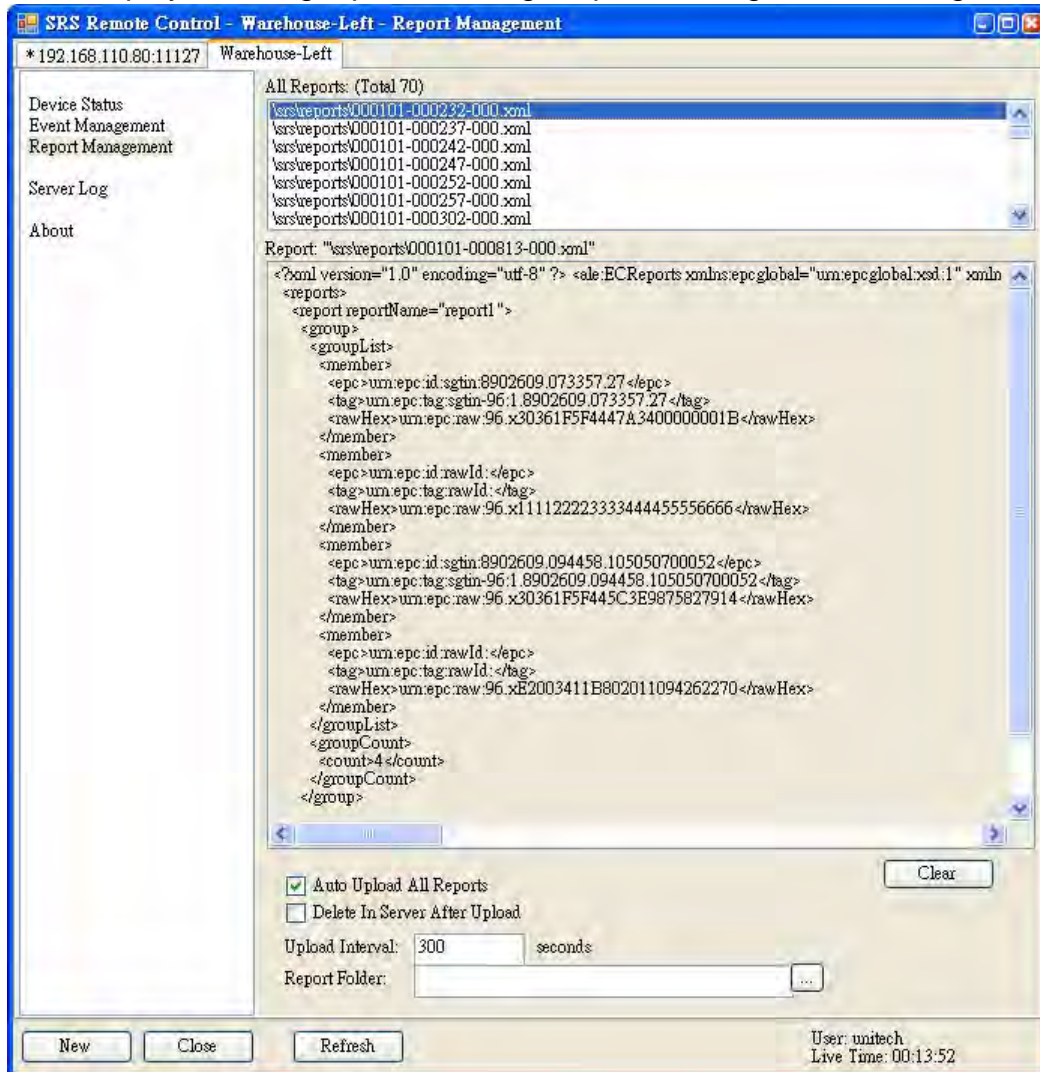

1. Click **Refresh** to load the latest reports into the **All Reports:** field.
2. Double click the desired report in the **All Reports:** field so that it opens in the middle of the screen. Click **Clear** to clear the screen and view the report with fresh data.
3. Check **Auto Upload All Reports** to upload reports to the computer.
4. Check **Delete In Server After Upload** to delete the report after uploading.
5. In the **Upload Interval:** field, set the **Upload Interval** in units of seconds (by default, the value is set at **300** seconds).
6. Choose the preferred folder to store reports in XML format on the computer.

Click on the IP address tab to view reports that set to send out to computers in the network. Click **Refresh** and select a desired IP address. Click **Clear** to clear the screen and view the report with fresh data, or click **Delete** to remove the report page.

### Viewing Server Log

Click **Server Log**, and log events on the Smart-Reader Server display in the right pane. Click **Clear** to clear the screen and view fresh logs.

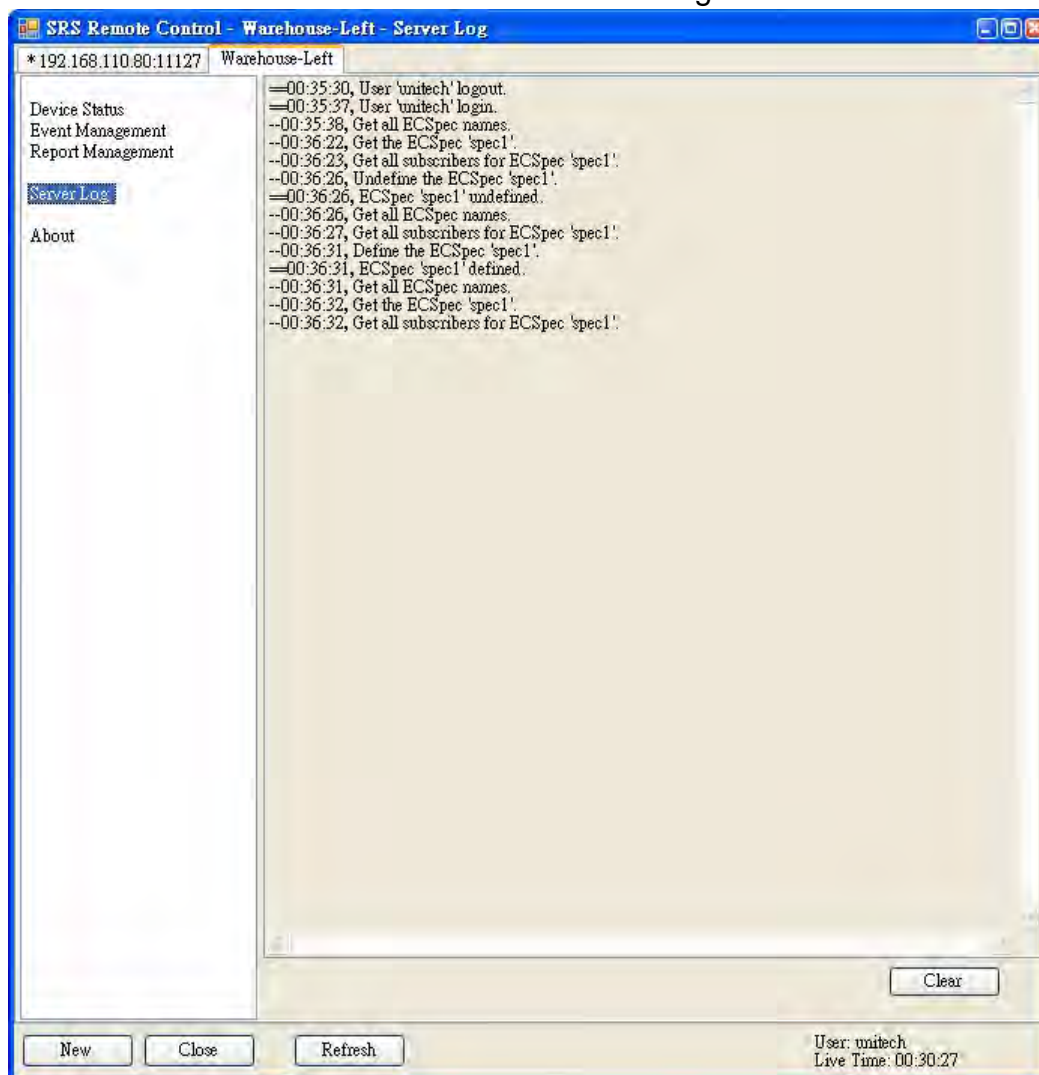

## Using the Application Programming Interface

Besides using the built-in RS700 Smart-Reader Server and SRSRC, develop or customize RFID applications based on specified requirements. To learn more about the API, please refer to the Unitech Software Development Kit and Programming Manual.

## Connecting to BizTalk Server

RS700 supports Microsoft BizTalk Server for data collection. Connect to the BizTalk Server through the following:

1. Copy the UnitechAdapter.dll, which is on the Unitech Software Development Kit CD-ROM, to the BizTalk RFID Manager folder (C:\Program Files\Microsoft BizTalk RFID\bin).
2. Run RFID Manager.

- Right-click **Device Providers** in the left screen panel, and select **New Provider** to add a provider. The Add Provider screen appears.

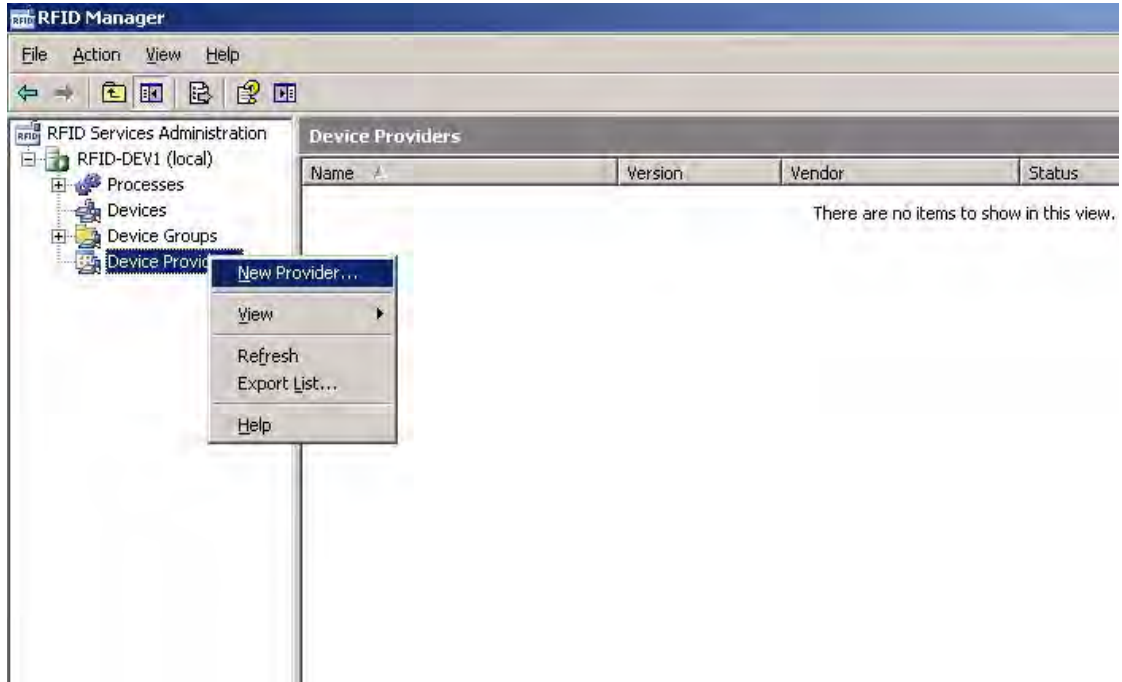

- Type a name for the provider, and click **Browse** to locate the file, Unitech-Adapter.dll which is saved in Step 1. Click **Register** to add the provider.

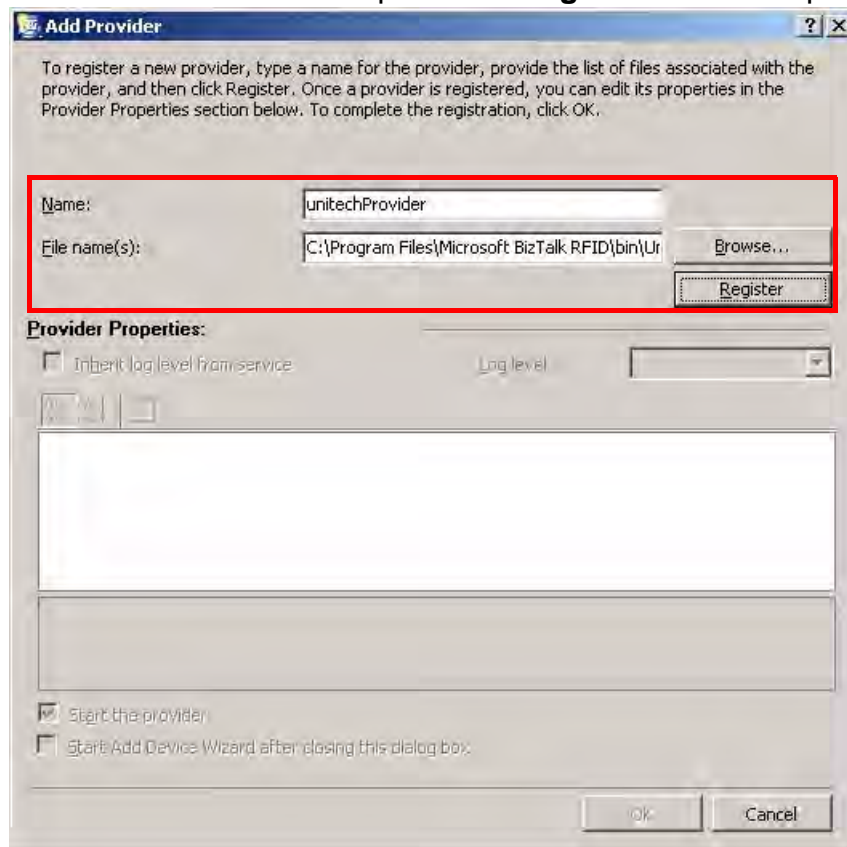

5. Click **OK** to confirm.

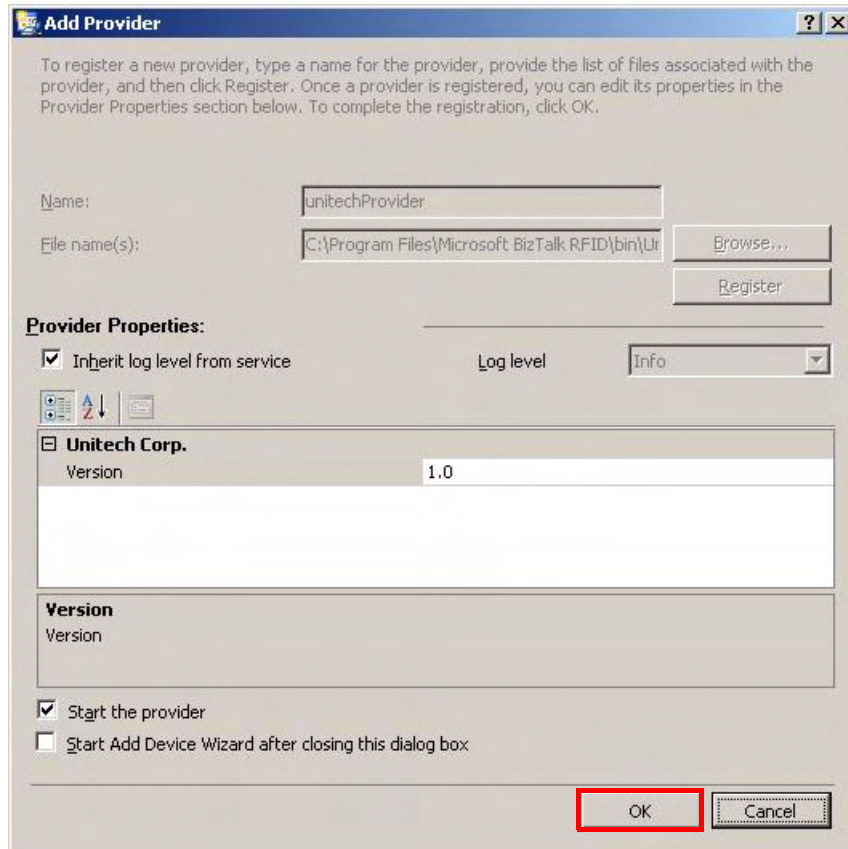

6. Right-click **Devices** in the left screen panel, and select **New Device** to add a device. The Add Device Wizard screen appears.

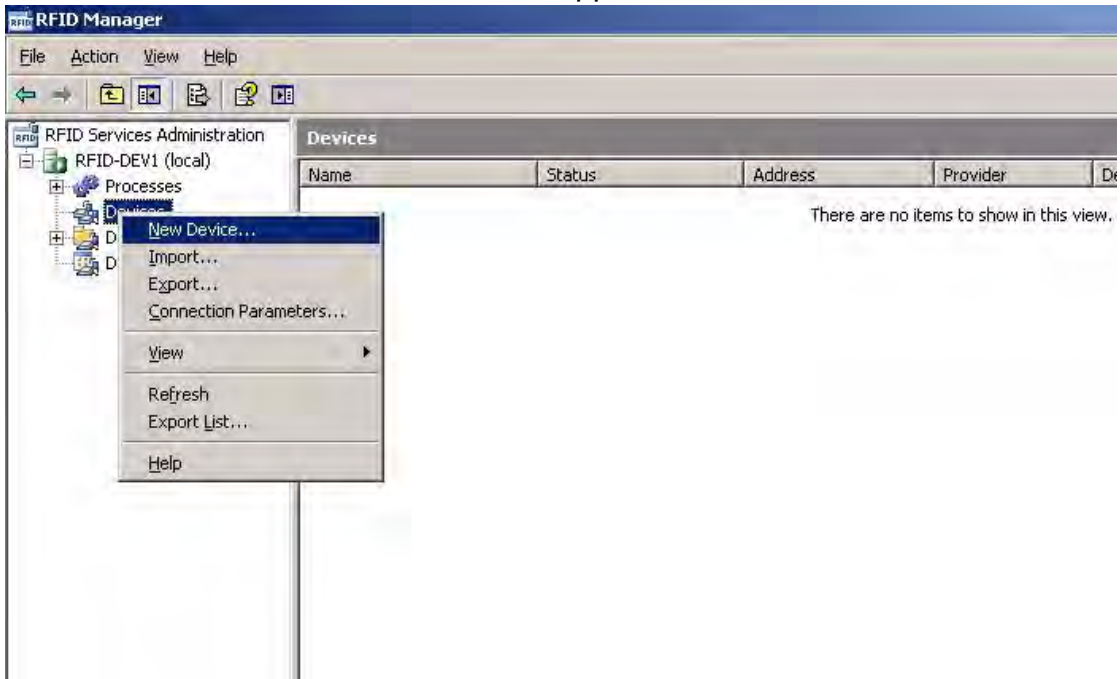

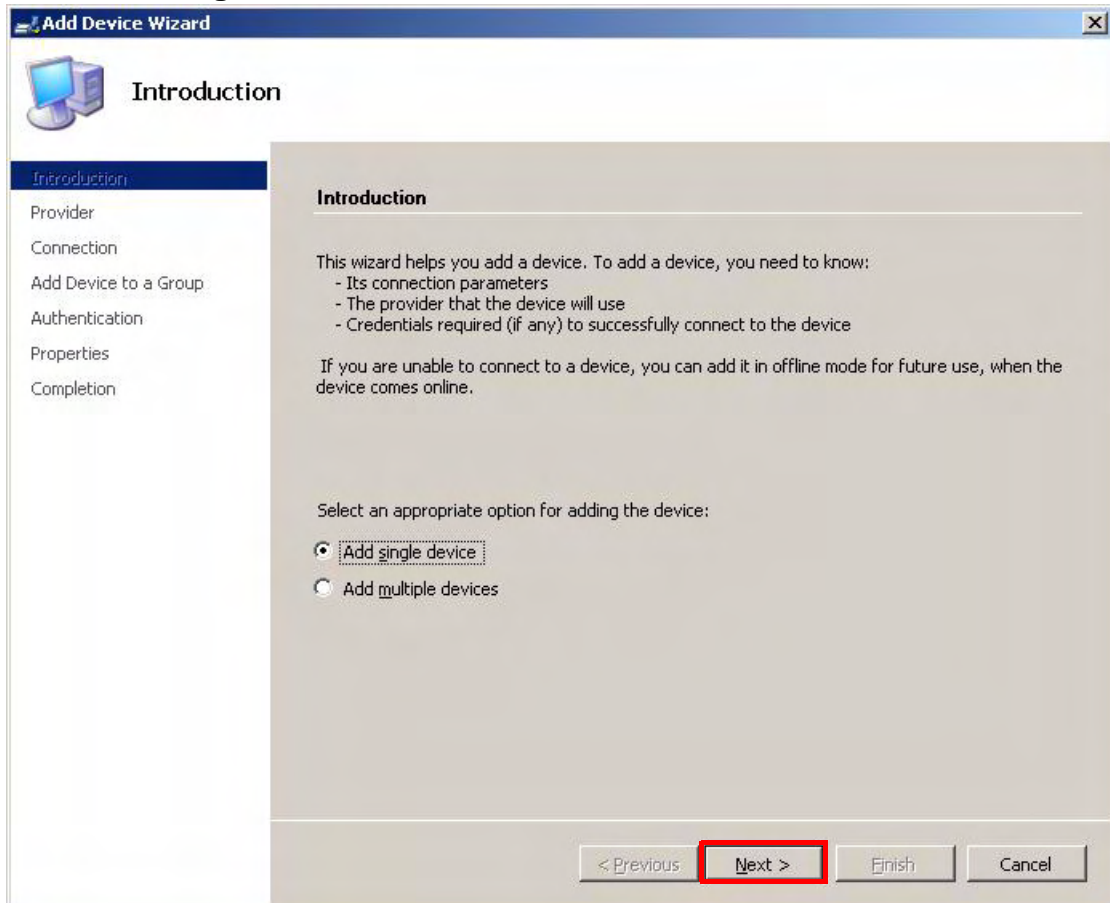
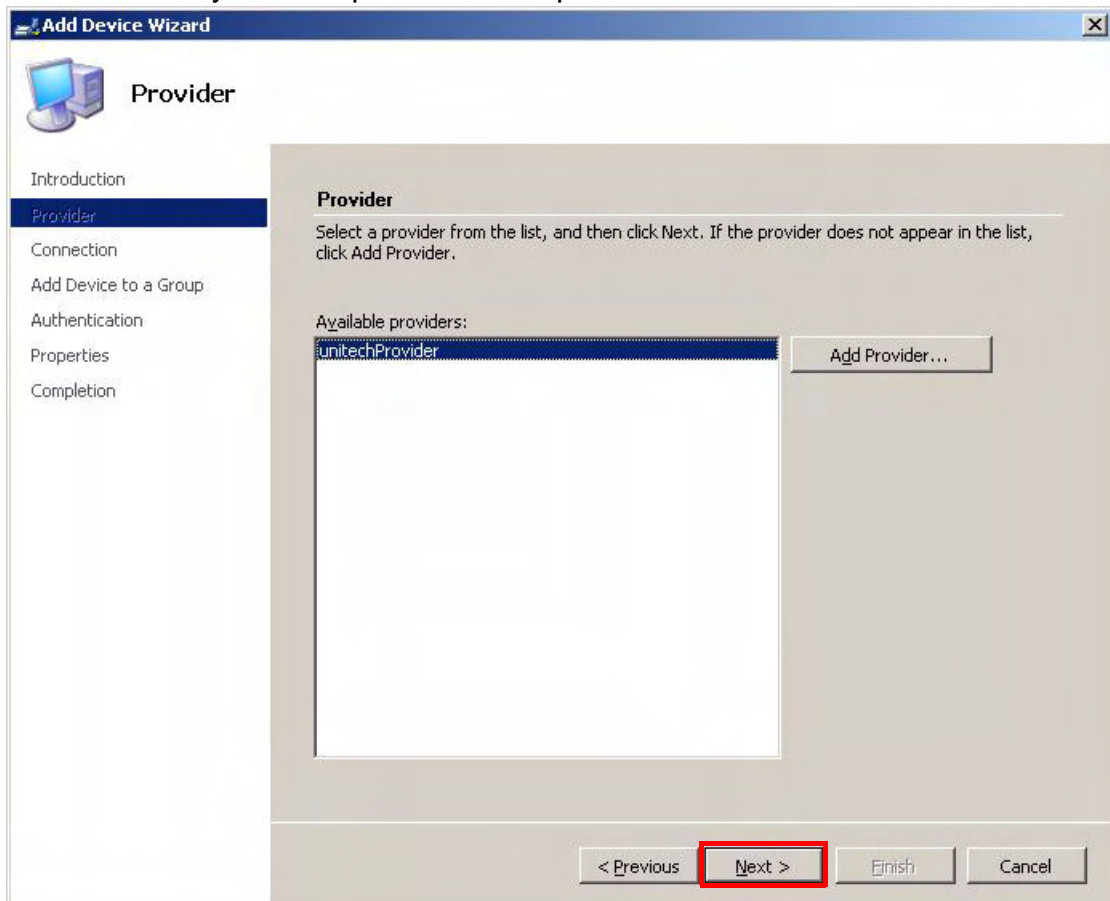
7. Check **Add single device**. Click **Next**.8. Select the newly created provider in Step 4. Click **Next**.



9. Input the RS700's IP address and port number. Click **Next**.

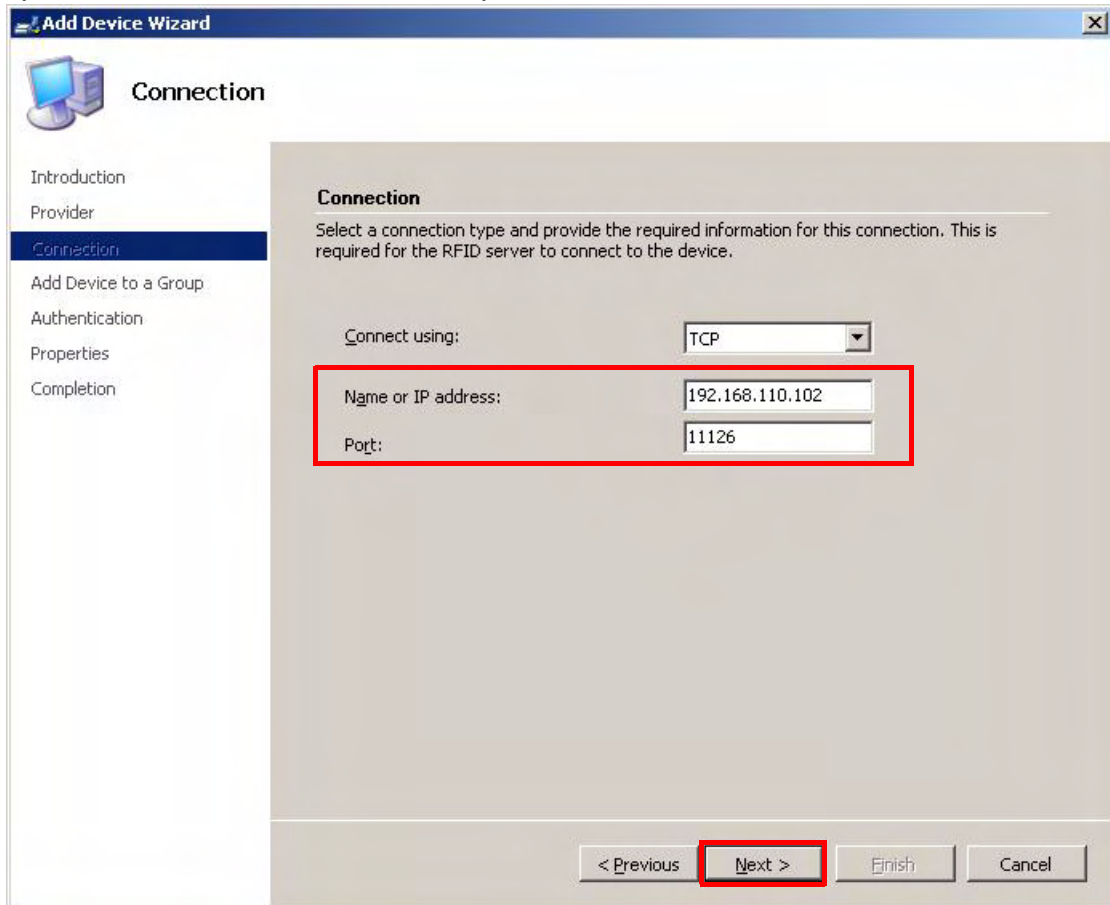

10. Click **Next**.

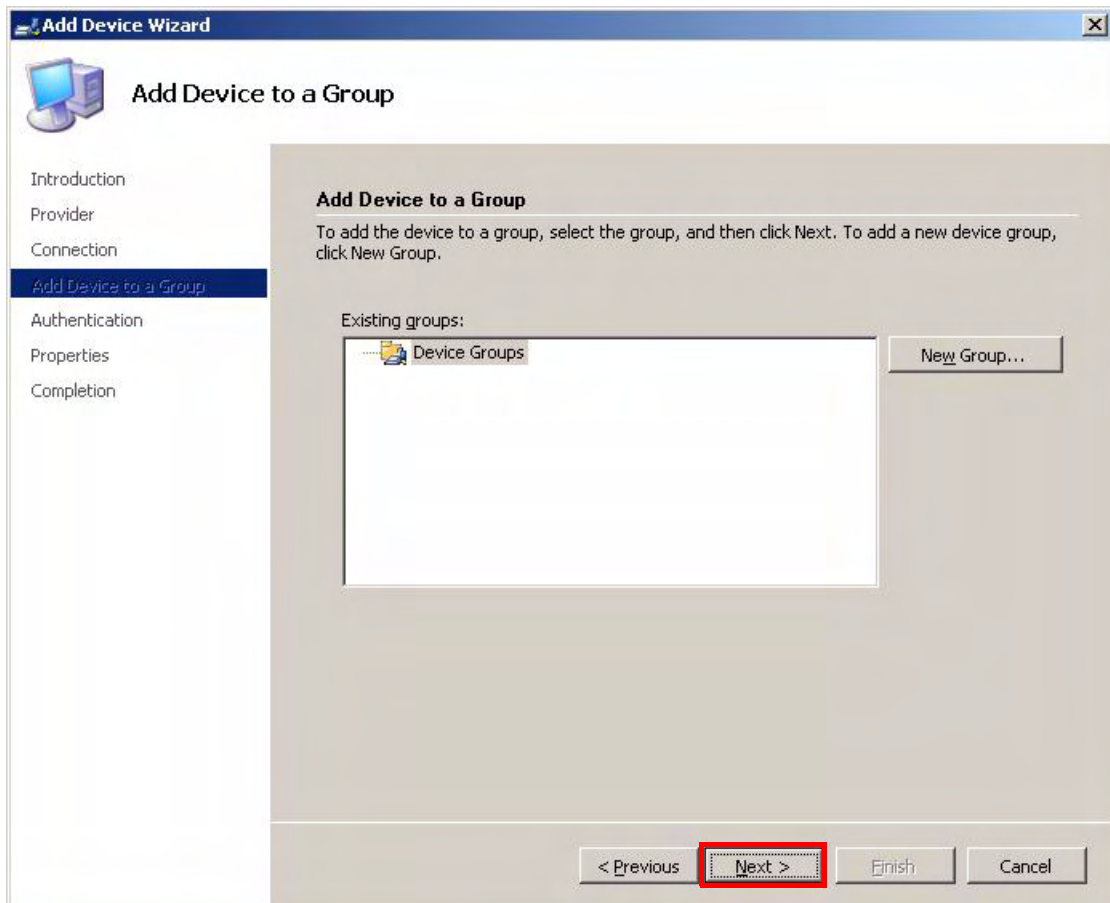

11. Enter the default user name and password as **unitech**. Click **Next**.

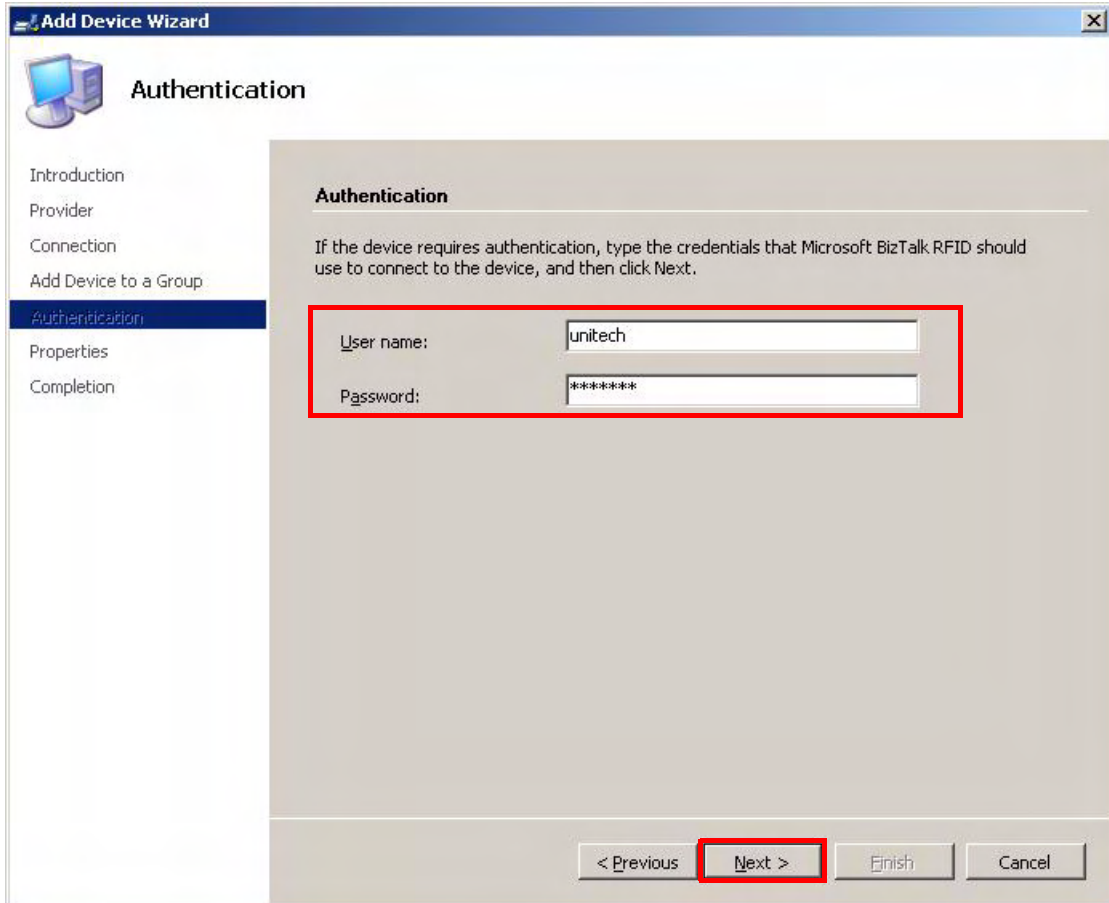

The screenshot shows the 'Add Device Wizard' window with the 'Authentication' step selected in the left-hand navigation pane. The main area is titled 'Authentication' and contains the following text: 'If the device requires authentication, type the credentials that Microsoft BizTalk RFID should use to connect to the device, and then click Next.' Below this text are two input fields: 'User name:' with the value 'unitech' and 'Password:' with the value '\*\*\*\*\*'. A red box highlights these two fields. At the bottom of the window, there are four buttons: '< Previous', 'Next >', 'Finish', and 'Cancel'. The 'Next >' button is highlighted with a red box.

12. Type a name for the device. Click **Next**.

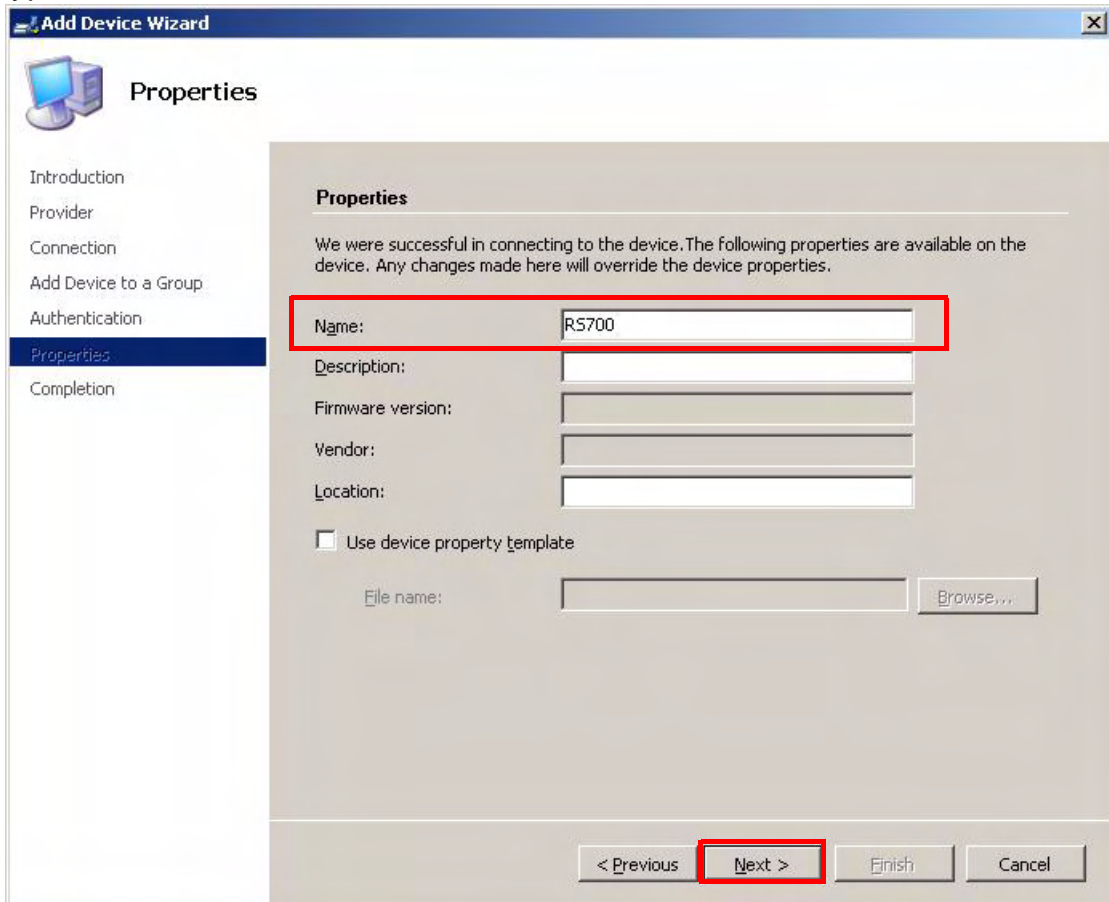

The screenshot shows the 'Add Device Wizard' window with the 'Properties' step selected in the left-hand navigation pane. The main area is titled 'Properties' and contains the following text: 'We were successful in connecting to the device. The following properties are available on the device. Any changes made here will override the device properties.' Below this text are several input fields: 'Name:' with the value 'RS700', 'Description:', 'Firmware version:', 'Vendor:', and 'Location:'. A red box highlights the 'Name:' field. Below these fields is a checkbox labeled 'Use device property template' which is unchecked. At the bottom of the window, there are four buttons: '< Previous', 'Next >', 'Finish', and 'Cancel'. The 'Next >' button is highlighted with a red box.

## 13. Click **Finish**.

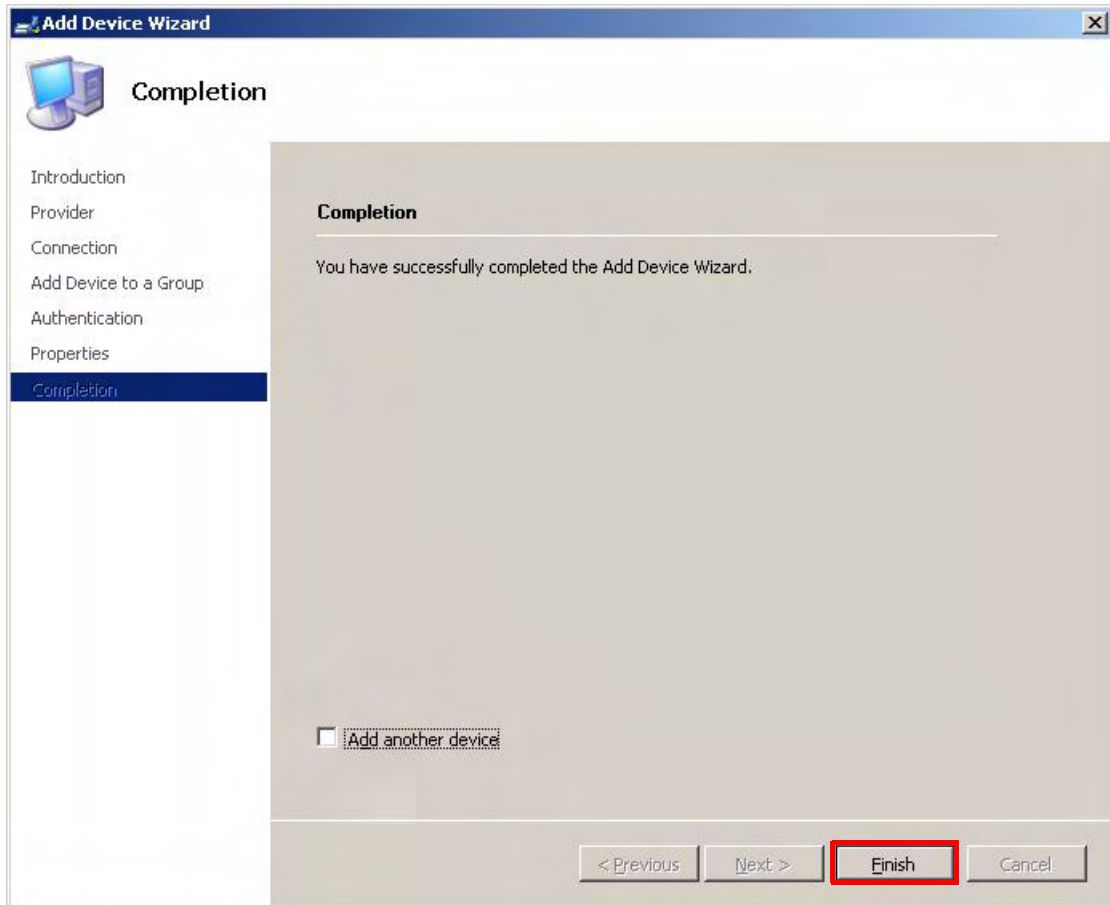

## 14. Right-click the device, and select **View Tags**. The View Tags screen appears.

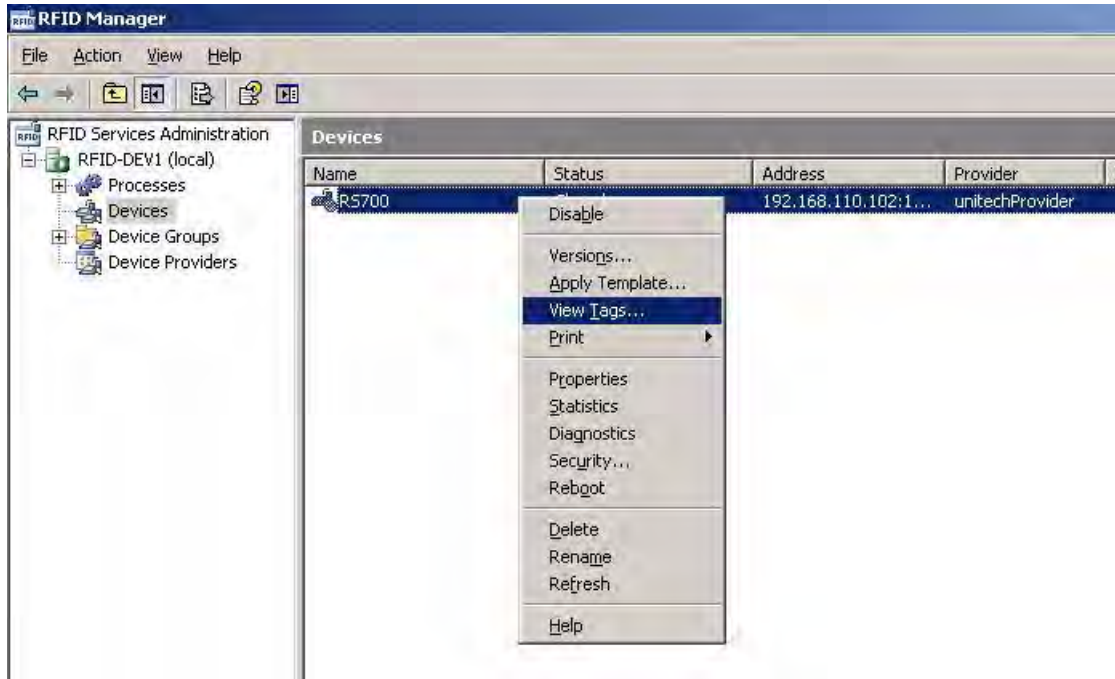

15. Data collected from the RS700 displays in the **Tags:** field. Setup the interval from the **Refresh interval:** drop down menu to update the screen automatically. Or, click **Clear** or **Refresh** to update the screen manually.

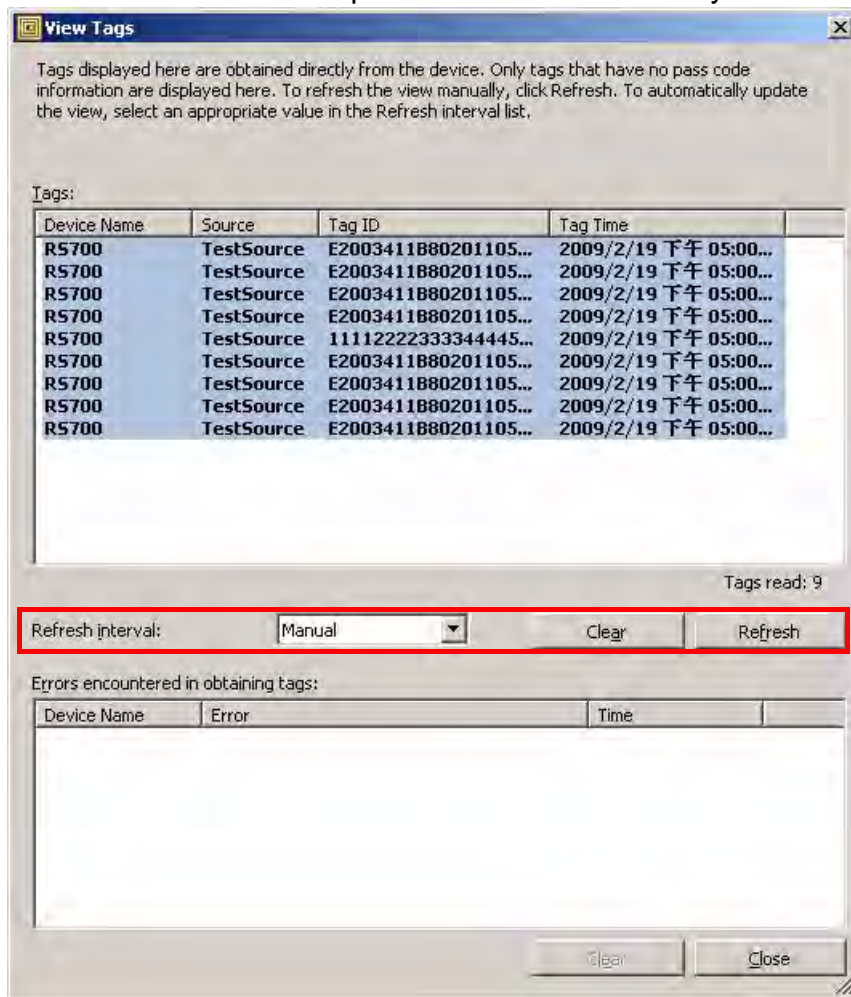

## Connecting to Oracle Sensor Edge Server

The RS700 supports the Oracle Sensor Edge Server (SES) for data collection. Connect to SES through the following:

1. Stop SES.
2. Copy the three files, SmartReaderAdapter.jar, SmartReaderDevice.jar and SmartReaderDispatcher.jar, which are on the Unitech Software Development Kit CD-ROM, to the path **C:\Oracle\product\10.1.3.1\AS\j2ee\home\applications\edge\edge\extensions**.
3. Restart SES.
4. Open the web browser and type **http://127.0.0.1:7777/edge** to login to the server on the local host.
5. Click **MyEdgeServer**.
6. Click **Change dispatcher**.

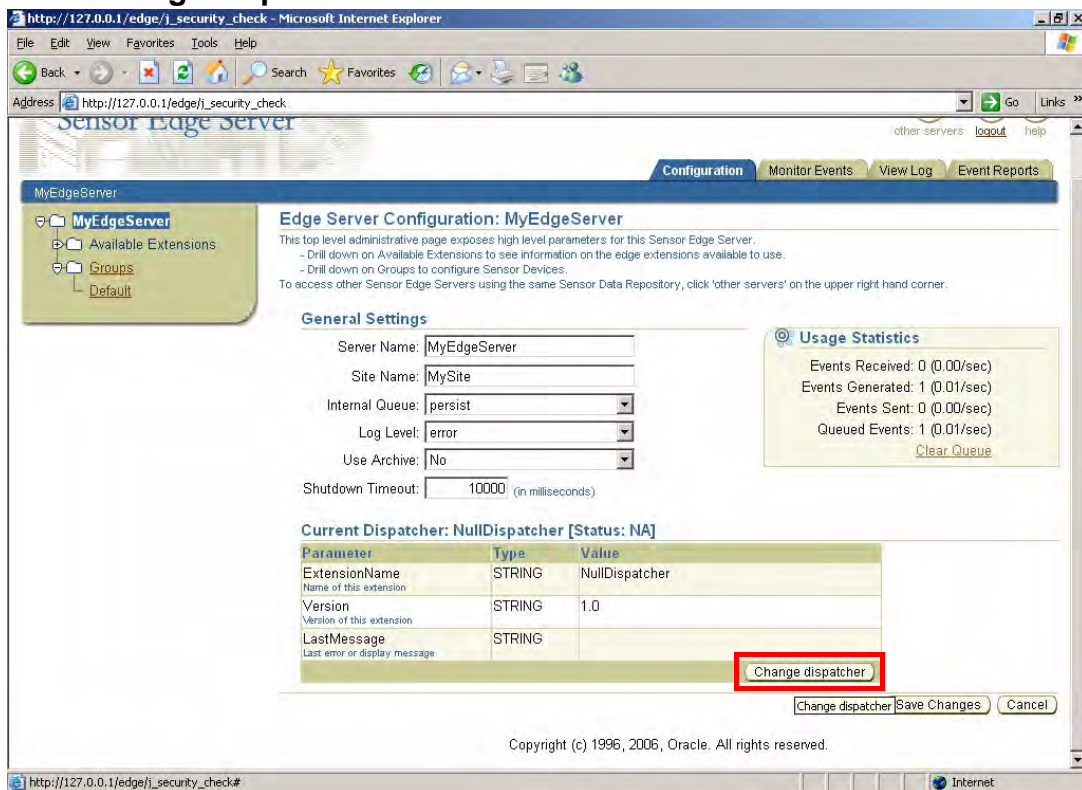

## 7. Select Smart Reader Dispatcher. Click Select.

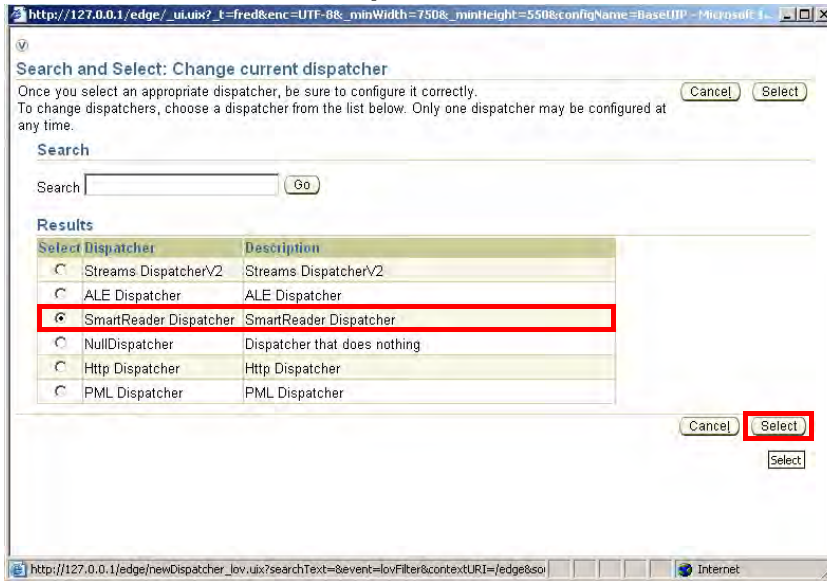

## 8. Set the Log Level to All. Click Save Changes.

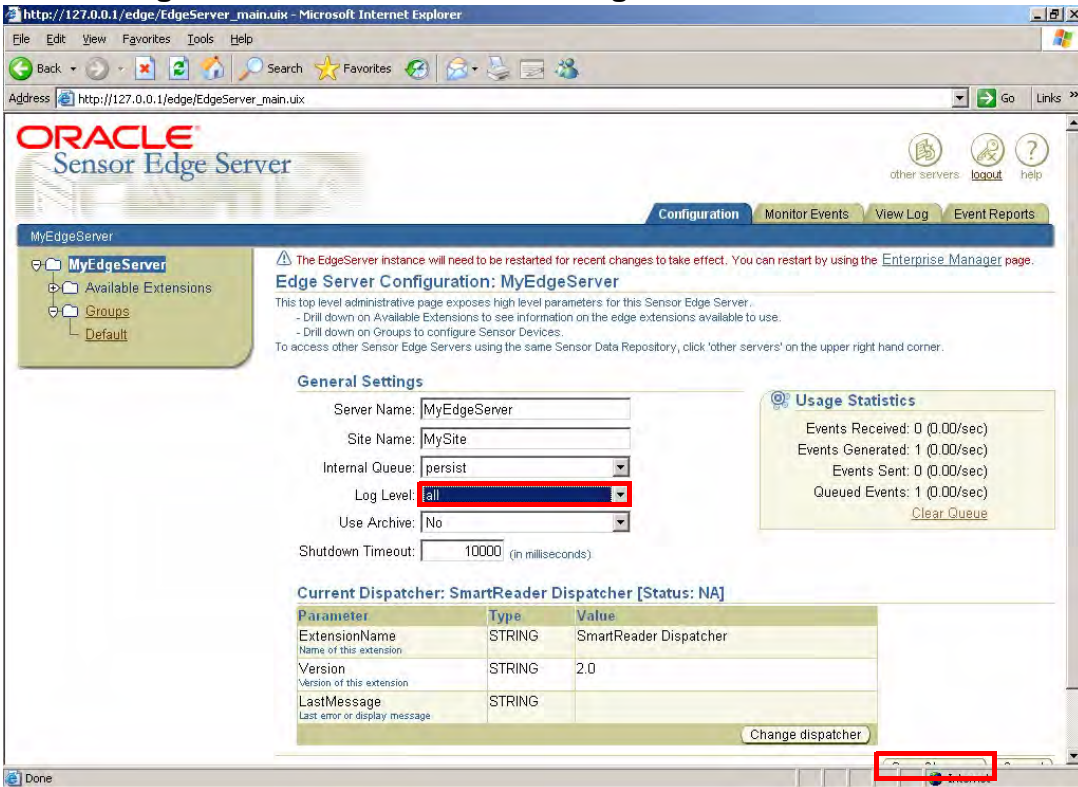

## 9. Click MyEdgeServer → Groups → Default.

## 10. Click Add new device.

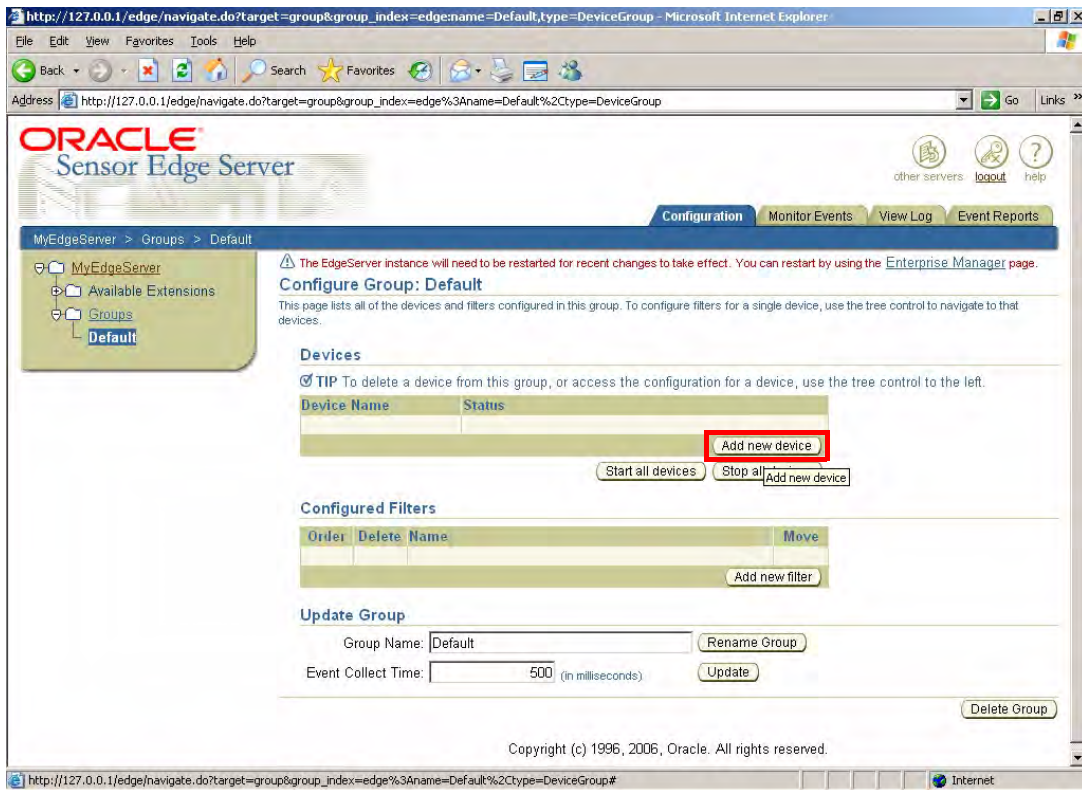

## 11. Select Smart Reader Device.

## 12. Type a name for the device. For example, RS700. Click Select.

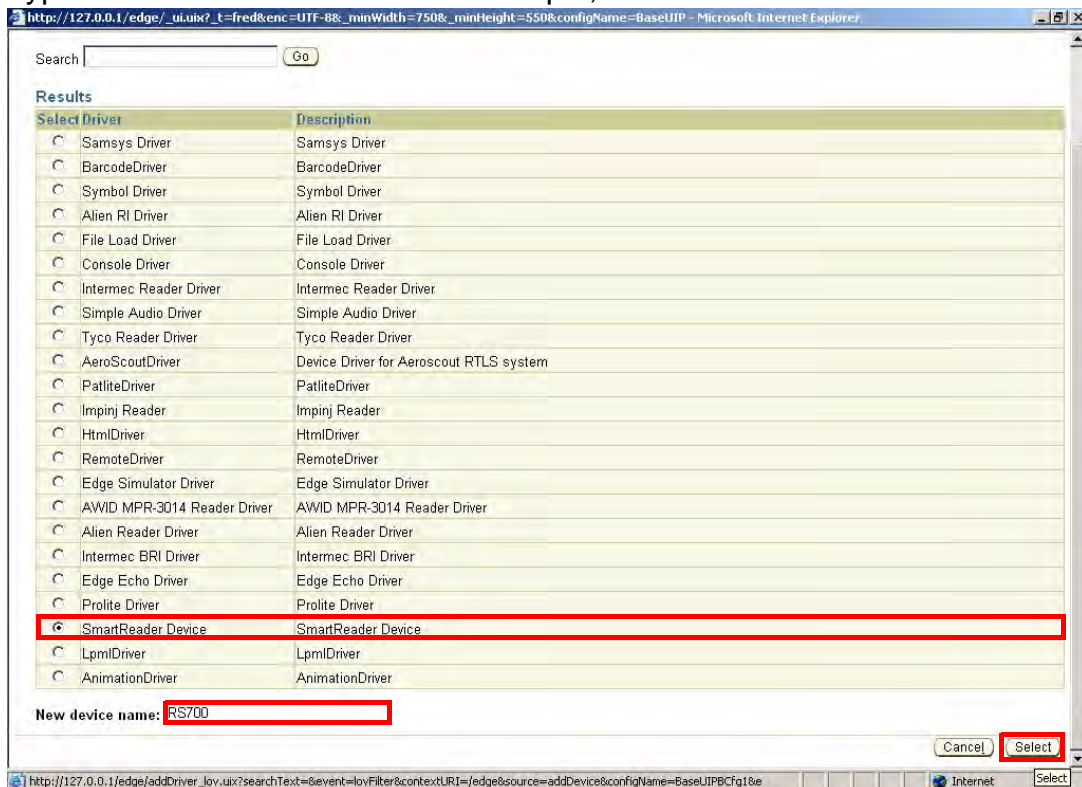

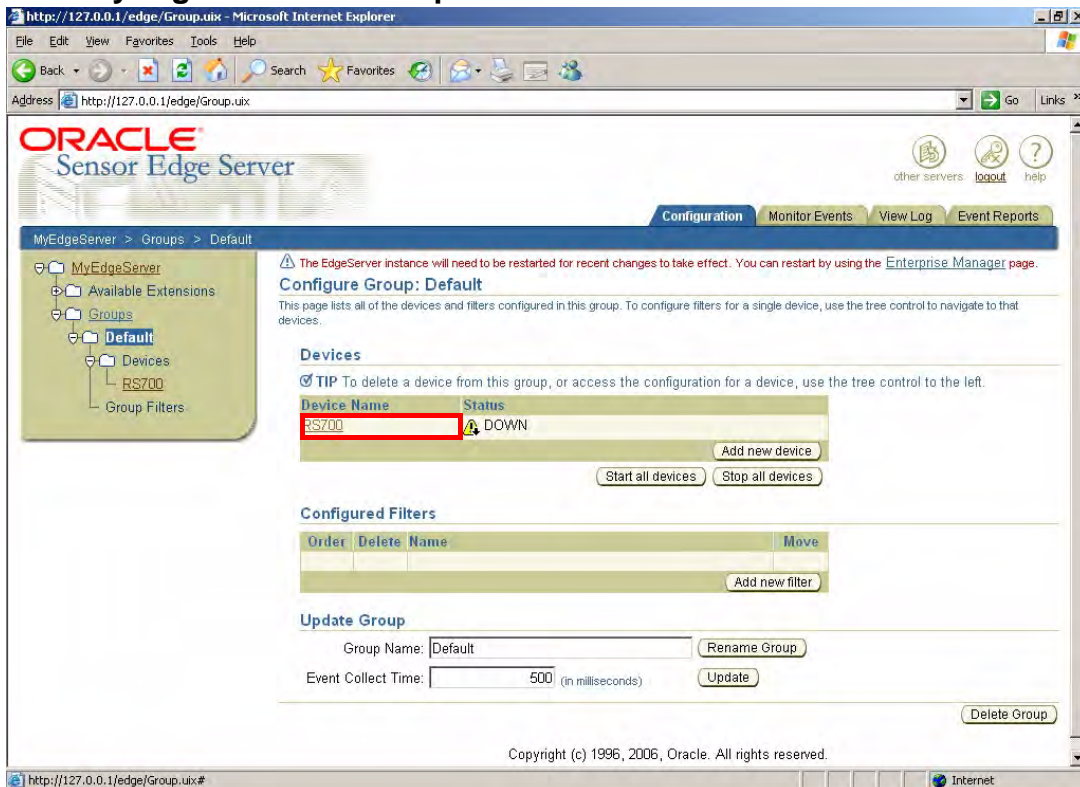
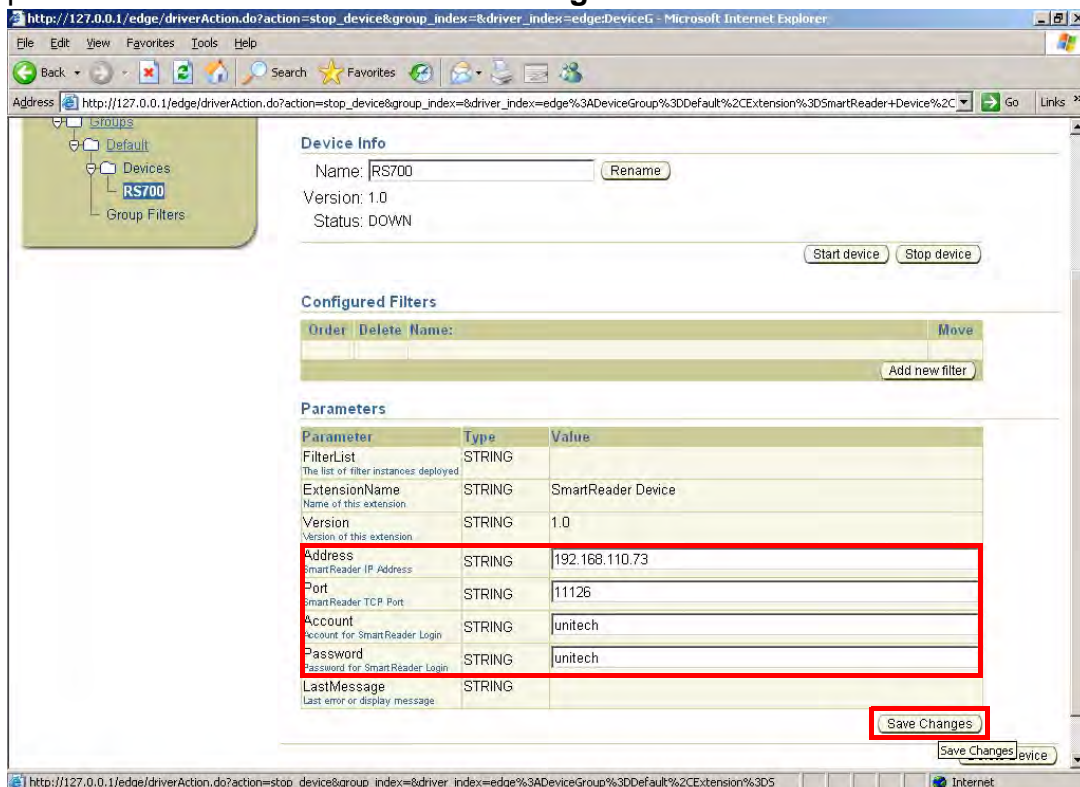
13. Click **MyEdgeServer** → **Groups** → **Default** → **RS700**.14. Input the RS700's IP address and port number, and the default user name and password as **unitech**. Click **Save Changes**.

## 15. Restart SES.

16. Click **MyEdgeServer** → **Groups** → **Default** → **RS700**.



## 17. Click **Start all devices**.

The server will log the event in the Monitor Events tab, when the RS700 collects RFID tags.

The screenshot shows the Oracle Sensor Edge Server web interface. The browser address bar displays `http://127.0.0.1/edge/Monitor.uix`. The page title is "ORACLE Sensor Edge Server". The navigation menu includes "Configuration", "Monitor Events" (highlighted in red), "View Log", and "Event Reports".

The "Monitor Events" section contains the following text:

This page monitors events that have recently moved through the Edge Server queue.  
 The Inbound Queue displays events from the application and the Outbound Queue displays events from the device drivers.  
 TIP This page will only function properly if the log level is set to 'monitor' or higher.

The "Inbound Queue" section is currently empty.

The "Outbound Queue" section contains a table with the following data:

Details	Type	Description	ID	Device Name	Data	Time
	RFID Observation (subtype=0)		urn:epc:raw:96.xE2003411B802011055281243			Wed Mar 04 10:25:25 CST 2009
	RFID Observation (subtype=0)		urn:epc:raw:96.xE2003411B802011055054304			Wed Mar 04 10:25:25 CST 2009
	RFID Observation (subtype=0)		urn:epc:raw:96.xE2003411B802011055054314			Wed Mar 04 10:25:25 CST 2009
	RFID Observation (subtype=0)		urn:epc:raw:96.xE2003411B802011055054303			Wed Mar 04 10:25:25 CST 2009
	RFID Observation (subtype=0)		urn:epc:raw:96.xE2003411B802011055054315			Wed Mar 04 10:25:25 CST 2009
	RFID Observation (subtype=0)		urn:epc:raw:96.xE2003411B802011055054305			Wed Mar 04 10:25:25 CST 2009
	RFID Observation (subtype=0)		urn:epc:raw:96.xE2003411B802011055281241			Wed Mar 04 10:25:25 CST 2009
	RFID Observation (subtype=0)		urn:epc:raw:96.xE2003411B802011055054266			Wed Mar 04 10:25:25 CST 2009
	RFID Observation (subtype=0)		urn:epc:raw:96.xE2003411B802011055281242			Wed Mar 04 10:25:25 CST 2009
	RFID Observation (subtype=0)		urn:epc:raw:96.xE2003411B802011055281240			Wed Mar 04 10:25:25 CST 2009

## Advanced Settings

The RS700 provides a standard interface to setup the terminal, and It is possible through this to make connections and perform remote control functions.

### Connecting to a LAN Network

#### Obtaining an IP Address

Connect to a network through the following:

1. Connect the computer to a DHCP enabled network.
2. Connect the Ethernet cable to the Ethernet Port on the RS700's bottom panel, and rotate the cable cap clockwise to secure the connection.
3. Connect the RS700 to the same network via DHCP. The DHCP server will assign an IP address to the RS700.
4. On the computer, click **Start** → **Programs** → **Smart-Reader Server Remote Control** → **Reader Discovery**.
5. Click **Discovery** to lookup the DHCP client in the same subnet.

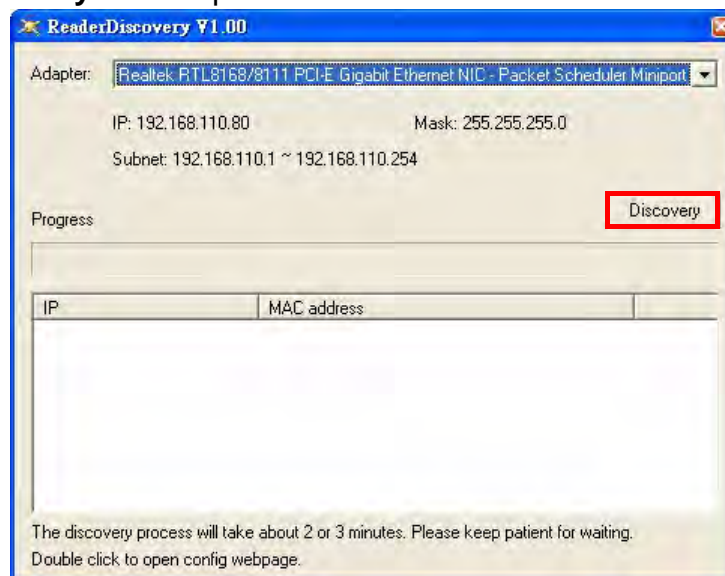

- Refer to the MAC address label attached the RS700's rear panel, and discover the RS700's IP address in the list box. Double-click the IP address to open the configuration webpage in the default browser.

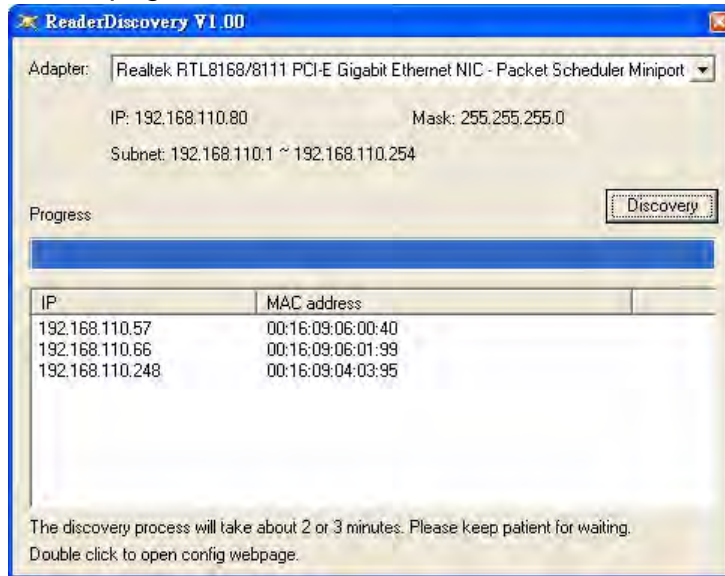

- The RS700 WebConfig Server window appears with basic information about the RS700, such as program version numbers and system memory.

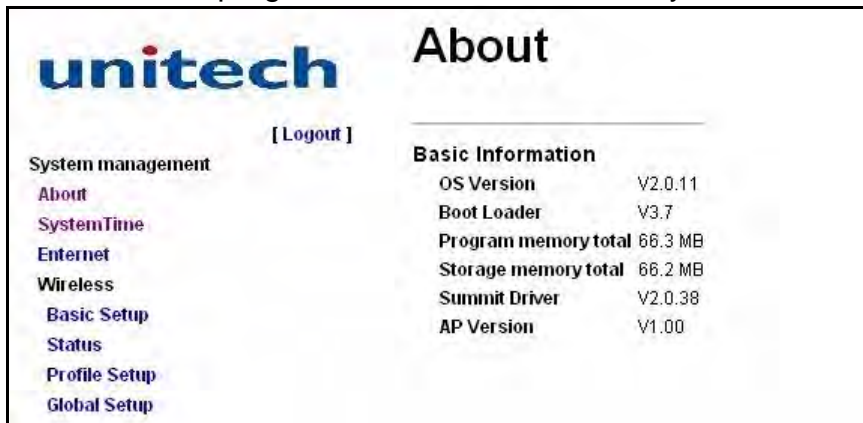

The built-in RS700 WebConfig Server is a web-based interface, which can configure the RS700 on a remote computer.

### Setting the System Time

Synchronize the system time with the remote computer via the RS700 WebConfig Server. Set the system time through the following:

1. Click **SystemTime** in the left screen panel. The System Time Setup page appears in the right screen panel with the current settings.

The screenshot shows the 'System Time Setup' page. On the left, under 'System management', the 'SystemTime' link is highlighted with a red box. The main content area features a 'Time Zone' dropdown menu currently set to '(GMT+11:00) Magadan, Solomon Is., New Caledonia'. Below this are six input fields for time configuration: Year (2008), Month (11), Day (5), Hour (12), Min (00), and Sec (00). At the bottom right, there are 'Apply' and 'Reset' buttons.

2. Click **Reset** to clear all the fields.
3. Select the desired time zone, and input the preferred date and time.
4. Click **Apply** to save the settings. A dialog box appears with the message **Set System Time OK!**.

## Setting up Ethernet connection

It is possible to configure the Ethernet settings on this page.

1. Click **Ethernet** in the left screen panel. The Ethernet Setup page appears in the right screen panel with the current settings.

The screenshot shows the 'Enternet Setup' page. In the left sidebar, the 'Ethernet' link is highlighted with a red box. The main content area has two radio button options: 'Obtain an IP address via DHCP' (unselected) and 'Specify an IP address' (selected). Below these are several input fields: IP Address (192.168.112.233), Subnet Mask (255.255.255.0), and Default Gateway (192.168.112.244). Under the heading 'Name Servers', there are fields for Primary DNS and Secondary DNS. Under the heading 'WINS', there are fields for Primary WINS and Secondary WINS. 'Apply' and 'Reset' buttons are located at the bottom right.

2. Select the DHCP server to automatically assign an IP address, or manually specify an IP address.
3. Select **Specify an IP address**, input the IP address, subnet mask, default gateway and etc.
4. Click **Apply** to save the settings. A box appears with the message **Set Ethernet OK!**. While the message **Input Error, please check!** indicates incomplete input.

## Connecting to a WLAN Network

It is possible to send and receive signals to a Wi-Fi network, and synchronize files with the RS700's embedded WLAN interface.

**NOTE:** Wi-Fi access requires a separate service contract through a wireless service provider. Contact a wireless service provider for more information.

A wireless network can be added when the network is detected or by manually entering information settings. Determine if authentication information is needed before proceeding through the following steps.

Setup a wireless LAN via RS700 WebConfig Server through the following:

1. Click **Profile Setup** in the left screen panel. The Wireless Profile page appears in the right screen panel. Click **New** to add a new profile.

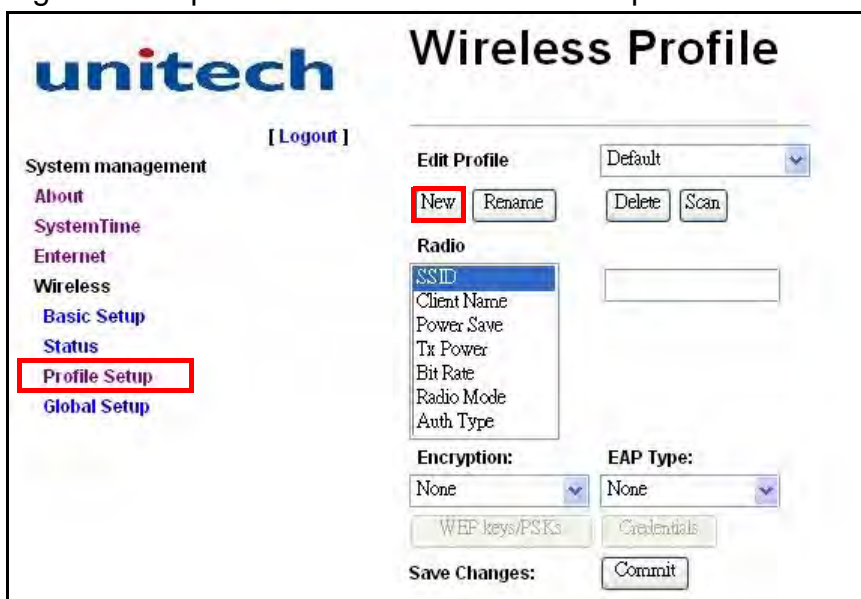

2. Enter the profile name in the dialog box. Click **Ok**.

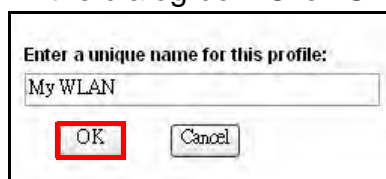

- Enter the SSID for the wireless network. Scroll down the **Encryption** drop down menu to select the wireless encryption type. Click **WEP keys/PSKs**.

The screenshot shows the 'Wireless Profile' configuration page. On the left is a navigation menu with 'Wireless' selected. The main area has 'Edit Profile' set to 'My WLAN'. Below that, the 'Radio' section has a dropdown menu open. The 'Encryption' dropdown is set to 'Manual WEP', and the 'EAP Type' dropdown is set to 'None'. The 'WEP keys/PSKs' button is highlighted with a red box. The 'Save Changes' section has a 'Commit' button.

- Enter the WEP keys in the dialog box. Click **OK**.

The dialog box prompts the user to enter 10 or 26 Hex digits (A-F, 0-9) or 5 or 13 ASCII characters. There are four input fields for 'Tx Key' with radio buttons. The first field contains '1234567890'. The 'OK' button is highlighted with a red box.

- In the Wireless Profile page, click **Commit** to save the profile.
- Click **Basic Setup** in the left screen panel. The Wireless Basic page appears in the right screen panel. Click **Reset** to clear all fields.

The screenshot shows the 'Wireless Basic' configuration page. The 'Basic Setup' option in the left navigation menu is highlighted with a red box. The 'Enable Radio' radio button is selected. The 'Active Profile' dropdown is set to 'Default'. The 'Obtain an IP address via DHCP' radio button is selected. The 'Name Servers' section has input fields for Primary DNS, Secondary DNS, Primary WINS, and Secondary WINS. The 'Reset' button is highlighted with a red box.

7. Select **Enable Radio**. Scroll down the Active Profile list to select the created profile.

The screenshot shows the Unitech Wireless Basic configuration interface. On the left is a sidebar with navigation links: System management, About, SystemTime, Ethernet, Wireless, Basic Setup, Status, Profile Setup, and Global Setup. The main content area is titled 'Wireless Basic' and features the Unitech logo. It includes a '[Logout]' link, radio buttons for 'Enable Radio' (selected) and 'Disable Radio', and a dropdown menu for 'Active Profile' with options 'Default', 'ThirdPartyConfig', 'Default', and 'My WLAN'. Below the dropdown are input fields for 'IP Address', 'Subnet Mask', and 'Default Gateway'. There is also a section for 'Name Servers' with input fields for 'Primary DNS', 'Secondary DNS', 'Primary WINS', and 'Secondary WINS'. At the bottom are 'Apply' and 'Reset' buttons.

8. Have the DHCP server automatically assign an IP address, or specify an IP address manually.
9. Select **Specify an IP address**, input the IP address, subnet mask, default gateway and etc.

NOTE: To enhance radio performance install the Wi-Fi Antennas on the RS700's top panel. See *Installing Wi-Fi Antenna* on page 6.

10. Click **Apply** to save the settings. Check the settings if the message **Input Error, please check!** appears.
11. Click **Status** in the left screen panel. The Wireless Status page appears in the right screen panel with information containing the active profile, radio status, client attributes, AP attributes, connection channel number, data rate, transmitted power, signal strength and etc. Click **Refresh** to refresh the page.

12. Click **Basic Setup** in the left screen panel and select **Disable Radio** in the Wireless Basic page to disable the access point.

## Managing your Wireless Profiles

Click **Profile Setup** in the left screen panel to manage wireless profiles in the Wireless Profile page.

- Edit Profile: Views a selected profile from the drop down menu on the right.
  - **New**: Creates a new profile.
  - **Rename**: Changes the name of a selected profile. The name should be unique, not being assigned to another profile. Input another name for this profile if the message **Profile name already exist!** appears.
  - **Delete**: Deletes a selected profile, which is not the active profile. Otherwise, the message **Active profile can not be deleted!** appears.



- **Scan:** A window appears with available APs. Click **Refresh** to receive the updated list. Referring to the received signal strength indication (RSSI) and whether data encryption is required or not, i.e., true or false (Secure), select a desired SSID from the list and click **Connect** to create a new profile with this SSID.
- **Radio:** Configures radio settings on the right fields.
  - **SSID:** Enters the service set identifier (SSID) for an access point.
  - **Client Name:** Assigns a client name for the terminal.
  - **Power Save:** Selects a power saving mode when idling. Value **CAM** stands for constant awake mode, **Maximum** for maximum power saving mode and default **Fast** for fast power saving mode.
  - **Tx Power:** Selects a transmit power for power saving. While the default is set to **Maximum**, lower the transmit power to 50, 30, 20, 10, 5 or 1mW. The lower power will result in a lower signal strength.
  - **Bit Rate:** Selects a suitable transmission rate to AP. While the default is set to **Auto**, set the bit rate to 1, 2, 5.5, 6, 9, 11, 12, 18, 24, 36, 48 or 54 Mbps. The higher rate will allow a shorter distance between access points.
  - **Radio Mode:** Selects a radio mode to AP. The terminal supports 802.11b/g. While the default is set to **BG optimized**, change to B rates only (802.11b data rates at 1, 2, 5.5 and 11 Mbps), G rates only (802.11g data rates at 6, 9, 12, 18, 24, 36, 48 and 54 Mbps) or BG rates full (All 802.11b/g rates).
  - **Auth Type:** Selects an 802.11 authentication type. While the default is set to no authentication needed to **Open**, change to **Shared** using WEP shared key or **LEAP** using LEAP protocol.
- **Encryption:** Selects the type of encryption to protect transmitted data. Available types are Manual WEP, Auto WEP, WPA PSK, WPA TKIP, WPA2 PSK, WPA2 AES, CCKM TKIP, CKIP Manual and CKIP Auto. While **WEP Keys/PSKs** appears; WEP keys or pre-shared keys are required.
- **EAP Type:** Selects an extensible authentication protocol. Available types are LEAP, EAP-FAST, PEAP-MSCHAP, PEAP-GTC and EAP-TLS. While **Credentials** appears, authentication credentials are required.

Click **Global Setup** in the left screen panel to adjust the wireless global settings in the Wireless Global page. The attributes in the **Property** field can apply to all profiles.



The screenshot displays the unitech Wireless Global configuration interface. On the left, a navigation menu includes System management, About, SystemTime, Ethernet, Wireless, Basic Setup, Status, Profile Setup, and Global Setup. The main area shows a table of properties and their values, with a [Logout] button above it. At the bottom, there are [Commit] and [Reset] buttons.

Property	Value
Roam Trigger	-70 dbm
Roam Delta	-50 dbm
Roam Period	-55 dbm
BG Channel Set	-60 dbm
Aggressive Scan	-65 dbm
CCX features	-70 dbm
WMM	-75 dbm
TX Diversity	-80 dbm
RX Diversity	-85 dbm
Frag Thresh	-90 dbm
RTS Thresh	
LED	
Tray Icon	
Hide Password	
Admin Password	
Auth Timeout	
Certs Path	
Ping Payload	
Ping Timeout ms	
Ping Delay ms	

Click **Logout** to exit the RS700 WebConfig Server.

## Establishing Terminal-PC Connection

---

### Installing Microsoft ActiveSync

In order to exchange data between the computer and the RS700, Microsoft ActiveSync must be installed on the computer. Use the USB Cable that comes with the RS700 to connect the terminal to the computer.

**NOTE:** Uninstall previous versions of Microsoft ActiveSync before installing the latest version.

### Additional Capabilities

- Backup and restore RS700 data.
- Copy (rather than synchronize) files between the RS700 and a desktop computer.
- Control the synchronization occurrence by selecting a synchronization mode. For example, synchronize continuously while connecting to a desktop computer or only when a synchronization command is selected.
- Select which information types are synchronized and control how much data is synchronized. For example, synchronize past appointments during the last six weeks.

Install Microsoft ActiveSync on the computer through the following:

- Close any open programs, including those that run during startup and disable any antivirus software.
- Download the ActiveSync software from the Microsoft ActiveSync Download page at:  
<http://www.microsoft.com/windowsmobile/en-us/help/synchronize/activesync45.mspx>.
- Browse to the location of the downloaded file, and double-click it. The installation wizard begins.
- Follow the instructions onscreen to install Microsoft ActiveSync.

## Connecting the terminal to Your Computer

After Microsoft ActiveSync is installed, make a connection through the following:

1. Connect the USB Cable to the USB port on the RS700's bottom panel, and rotate the cable cap clockwise to secure the connection.
2. Insert the other end of the USB Cable into a USB Port on the computer.
3. Microsoft ActiveSync starts automatically and configures the USB Port to work with the RS700. The New Partnership setup wizard will ask to setup a partnership.



**NOTE:** If Microsoft ActiveSync doesn't start automatically, click **Start** → **Programs** → **Microsoft ActiveSync**.

If a message appears indicating that it is unable to detect a connection, click **Cancel** and manually configure the communication settings by clicking **MAS** → **File** → **Connection Settings** → **Connect**.

4. Follow the onscreen instructions. The Microsoft ActiveSync window appears when the configuration is complete.

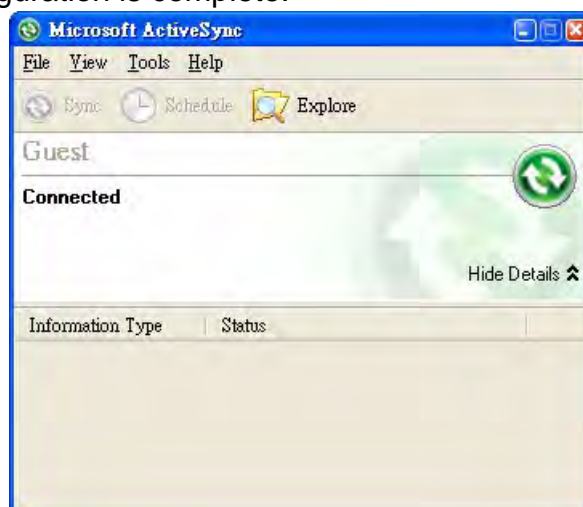

5. Synchronization will initiate, and it will synchronize periodically or upon connection.

### Using Microsoft ActiveSync to Exchange Files

Synchronization options can modify, including when to synchronize and what gets synchronized. In the Mobile Device window on the computer, click **Tools** → **Sync Options**.

For each type of information, the synchronization process can be hastened by limiting the amount of synchronized data. To do this, select a service and click **Settings**. After enabling a service, close and reopen Microsoft ActiveSync.

Synchronization occurs according to the options chosen while setting up Microsoft ActiveSync on the computer. If the default (On Connect) synchronization option in the Microsoft ActiveSync Setup Wizard is selected, simply connect the RS700 to the desktop computer and synchronization will take place.

If the disabled On Connect feature in Microsoft ActiveSync is selected, start ActiveSync through one of the following:

- On the computer, click **My Computer** → **Mobile Device folder**.
- Connect the USB cable between the computer and terminal.

Use Microsoft ActiveSync to exchange information from the terminal to the computer and vice versa. Changes made to the information on one location will not affect the information on the other. To automatically update information on both the RS700 and the computer, synchronize the information instead.

**NOTE:** Files created on the computer may need to be converted by ActiveSync so that they can be viewed and edited on the terminal, and vice versa.

Copy two types of information to the device: files and Pocket Access Windows CE Store information.

The following procedure only applies to copying files. Refer to the Microsoft ActiveSync Help on the computer for instructions on how to copy Pocket Access Windows CE Store information.

1. In the Microsoft ActiveSync window on the computer, click **Explore**. Windows Explorer opens the Mobile Device window for the terminal.
2. Locate a file to copy on the terminal or computer.
3. Do one of the following:
  - To copy the file to the terminal, right-click the file and click **Copy**. Place the cursor in the desired folder for the terminal, right-click and click **Paste**.
  - To copy the file to the computer, right-click the file and click **Copy**. Place the cursor in the desired folder on the computer, right-click and then click **Paste**.

## Using Remote Control

Besides configurations through the web-based interface, there are also ways to control the RS700 remotely with the computer via Microsoft Power Toys. It is possible to setup the system time, establish network connections or do any other settings on the RS700 Windows platform.

Use the remote control through the following:

1. On the computer, install WindowsMobilePowerToys.msi, which is on the Unitech CD-ROM.

**NOTE:** Download the latest PowerToys software from the Microsoft Download Center.

2. Connect the USB Cable to USB Port on the RS700's bottom panel, and rotate the cable cap clockwise to secure the connection.
3. Insert the other end of the USB Cable into a USB Port on the computer.
4. Microsoft ActiveSync starts automatically and configures the USB Port to work with the RS700.
5. Click **Start** → **Programs** → **ActiveSync Remote Display**.

**NOTE:** Alternatively, execute ASRDisp.exe in the Microsoft ActiveSync Remote Display folder.

6. A dialog box appears with message **The OS or CPU of this device is unknown to this application**. Click **OK**. The WindowsCE window opens with applications, such as SRS and WebConfig running on the RS700.

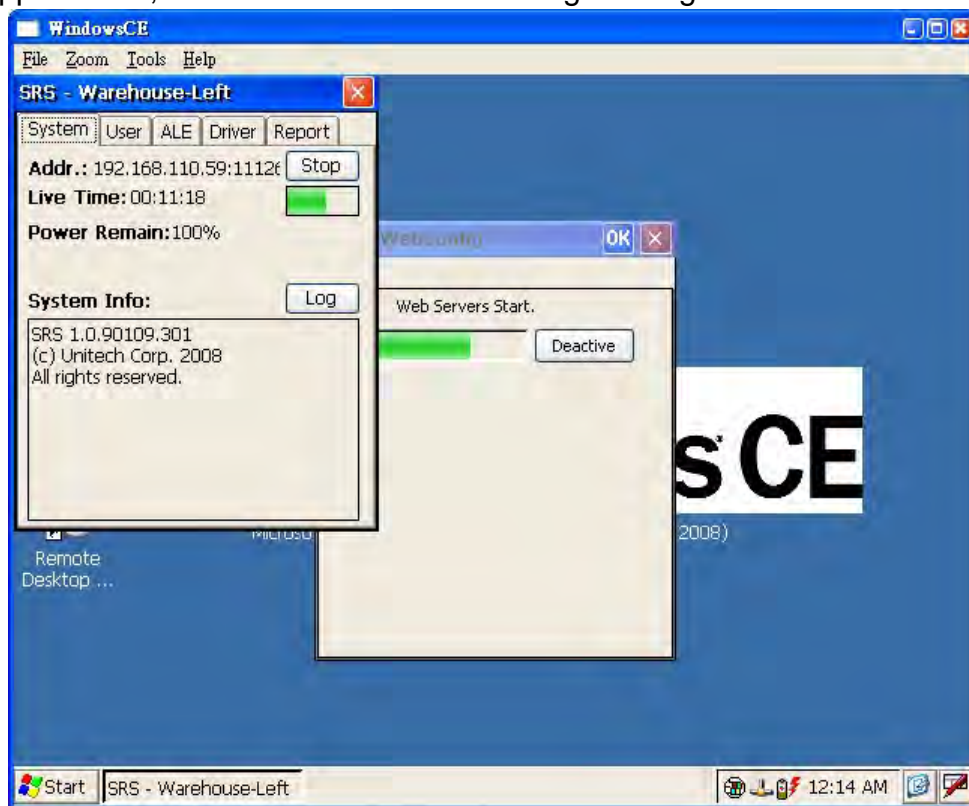

Click **Zoom** to adjust the zoom level at 1x, 2x or 3x. Click **File** → **Exit** to exit the remote control window.

## Troubleshooting

Unitech has a professional support team to answer any questions or technical related issues. If equipment problems occur please refer to the table below or contact a regional Unitech representative.

Problem	Solution
1. Cannot Backup Data.	<ul style="list-style-type: none"> <li>• Check if the Backup Battery Switch is on.</li> <li>• Send back to Unitech for RMA.</li> </ul>
2. Cannot Read a Tag.	<ul style="list-style-type: none"> <li>• Check whether the RFID Antenna is properly connected to the TNC Connector via Antenna Cable.</li> <li>• Check whether the Antenna Port is correct.</li> <li>• Check whether the tag is damaged.</li> <li>• Check the software settings, e.g., reader status, antenna port and etc.</li> <li>• Reset the RS700.</li> <li>• Send back to Unitech for RMA.</li> </ul>
3. Cannot Charge the Backup Battery.	<ul style="list-style-type: none"> <li>• Check if the Backup Battery Switch is on.</li> <li>• Send back to Unitech for RMA.</li> </ul>
4. The USB Communication Fails.	<ul style="list-style-type: none"> <li>• Reconnect the USB Cable.</li> <li>• Reset the RS700.</li> <li>• Send back to Unitech for RMA.</li> </ul>
5. Cannot Reset the RS700.	<ul style="list-style-type: none"> <li>• Make sure the Reset Button is pressed in.</li> <li>• Make sure the backup battery switch is turned off when removing external power.</li> <li>• Send back to Unitech for RMA.</li> </ul>

## System Specification

Processor/Memory	CPU	520Mhz Intel PXA270
	Memory	SDRAM: 64MB Flash ROM: 64MB
OS	Microsoft Windows CE 5.0	
Indicator	Data LED, RFID LED and Power LED	
Communication	USB 1.1 Client Serial RS232 Ethernet 10/100Base-T IEEE 802.11b/g Wireless LAN, CCX Compatible Relay Outputs (2) Optical Inputs (2)	
RFID Reader	Reader	R1000
	Protocol	EPCglobal Class1 Gen2
	Frequency	UHF 860MHz - 960MHz
	Output Power	Up to 1W and 4ERP with Antenna
	Antenna Number	4-port switch
	Channel	8-channel TX/RX
	Reading Distance	1 - 10 Meters Depending on Reading Points and Tags
	Tag Type	EPCglobal C1G2, ISO 18000-6C
SD Card Slot	Built-in 2GB Storage	
Power Source	Main Power	Input: 100-240Vac, 50/60MHz, 0.75A Output: 12V DC, 3A, 36W Max.
	Backup Power	3800mAh Rechargeable Lithium-Ion Battery
Enclosure	Weight	1750g (3.8 lbs.)
	Dimension	252mmL X 57.7mmH X 185.3mmW (9.9"L X 2.2"H X 7.2"W)
Environmental	Operating Temperature	-20°C - 50°C (-4°F - 122°F)
	Storage Temperature	-30°C - 70°C (-22°F - 158°F)
	Relative Humidity	0% - 95% (Non-condensed)
	Environmental Sealing	IP65 (Indoor and Outdoor Applications)
Certification	FCC, CE, NCC, BSMI, CCC, RoHS Compliance and TELEC	
Accessories	GPX-026XTPR8-763 RFID Antenna CFD200-NL Antenna cable, 24'	
Software	RS700 SDK RFID Middleware SDK Microsoft BizTalk RFID Oracle Sensor Edge Sever IBM WebSphere	



## Support

Region	Web site
Global Operation Center	<a href="http://www.unitech-adc.com">www.unitech-adc.com</a>
unitech Taiwan	<a href="http://adc-utt.unitech.com.tw">adc-utt.unitech.com.tw</a>
unitech Asia Pacific & Middle	<a href="http://www.unitech-utp.com.tw">www.unitech-utp.com.tw</a>
unitech China	<a href="http://www.ute.com.cn">www.ute.com.cn</a>
unitech Japan	<a href="http://www.unitech-japan.co.jp">www.unitech-japan.co.jp</a>
unitech America	<a href="http://www.ute.com">www.ute.com</a>
unitech Latin America	<a href="http://latin.ute.com">latin.ute.com</a>
unitech Europe	<a href="http://www.unitech-europe.nl">www.unitech-europe.nl</a>