

Wireless Motion Sensor User's Manual

Product Name : **Wireless Motion Sensor**

Model No : **SMT-230**

Input Power: 4.5V DC(Battery) / 5V/1A(Power Adaptor)

Features Description:

1. The use of Infrared Motion Detection of sensor detector, it self cannot transmits light wave of the infrared.
2. The use of three UM-3 AA 1.5V alkaline batteries ,battery power is insufficient to inform the host will automatically operate a very low power, the battery can be used for more than one years.
3. Easy link, when install at the first time to press the set button on the side of product Joining with Gateway 、Panel Coordinator or Route.
4. Can use the WPW-220 (Wireless Power Controller) do so with even control, For example: Corridor night auxiliary lighting. °
5. When the device is connected to the power supply, it will automatically cut off the battery power.
6. This device must be compatible with Gateway using, if beyond the effective reception distance will not be used.

Outline Dimensions:

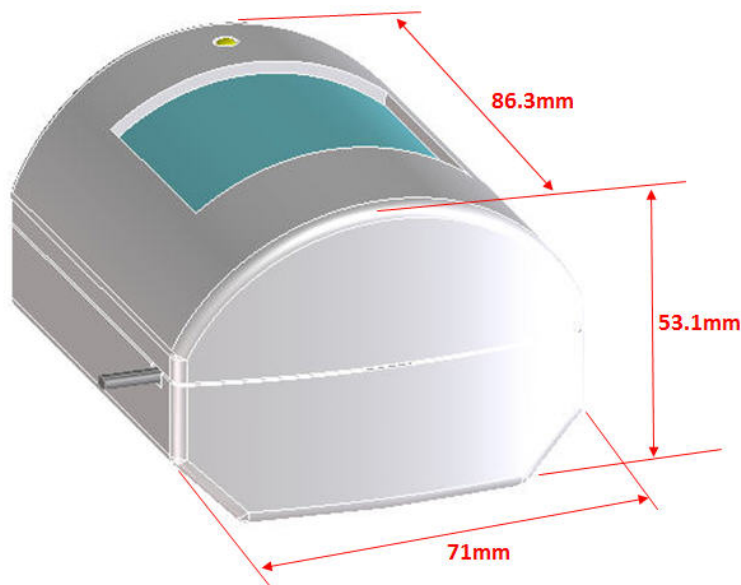

Installation Hints:

1. First use UM-3 AA 1.5V alkaline batteries into SMT-230 (Wireless Motion Sensor) battery holder, and check the battery positive and negative polarity marked is correct.
2. The SMT-230 (Wireless Motion Sensor) by pressing the SET button at the side, and then press the Gateway ∙ Panel Coordinator or Route at the bottom of the SET button, Wait for 1 second to 15 seconds. If green LED indicator light flash and long light that means linking success. If green LED indicator light flash and red LED long light that means fail.
3. The SMT-230 (Wireless Motion Sensor) placed on the need to detect the channel next to ∙ need to pay attention to the Wireless Motion Sensor detector window, do not be put into place where the sun, and not on where the ambient temperature is too high.
4. Can use the SMT-230 (Wireless Motion Sensor) signals through the Panel Coordinator, on the Wireless Power Controller do so even control. Join to link with Gateway, please reference user manual of Wireless Panel Coordinator).

Troubleshooting:

1. **Problem:** When link with Gateway ∙ Panel Coordinator or Route, there is no display of green LED indicator light flash and long light for SMT-230 (Wireless Motion Sensor to flash two or three times.
Solution:
 - a. Need to make sure the battery is good there is electricity, the installation of the battery positive and negative direction is correct.
 - b. May be not press set button, need to link with Gateway ∙ Panel Coordinator or Router again.
 - c. If the above handles are invalid, please contact with agency.
2. **Problem:** Unable to link with Gateway ∙ Panel Coordinator or Router.
Solution:
 - a. It needs to confirm the distance between SMT-230(Wireless Motion Sensor) and Gateway ∙ Panel Coordinator or Route. Wireless connects in non-camouflage straight line effective range 10 meters. May pull closer between booth's distance tests to have a look first, whether to have the improvement segment condition

Specification: :

UIS/Wireless Motion Sensor	
Model No.	SMT-230
Electrical Specification	
Transmit Frequency	2.4GHz ISM band, IEEE802.15.4: 2405 ~ 2480MHz
Detection Mode	Passive Infrared
Operation Range	Up to 200 meters (LOS)

AC Adapter	Input : AC 100 ~ 240V , 47 ~ 63Hz at 0.19A MAX Output : DC 5V/1A 5W MAX
Battery Type	AA Alkaline battery x 3
Battery Life	up to 3 year
Sensor Detection Range	8 M 25°C, Angle 110,
LED Indicator	Red
Environmental Requirement	
Operating Temperature	0°C to 40°C
Storage Temperature	-10°C to 55°C
Humidity	90% RH Max., Non-Condensing
Mechanical Specification	
Dimension (WxHxD, mm)	86.3*53.1*71mm
Weight (w/o Battery)	78g

This device complies with Part 15 of the FCC Rules. Operation is subject to the following two conditions:
(1) this device may not cause harmful interference,
and (2) this device must accept any interference received, including interference that may cause undesired operation.

Notice : The changes or modifications not expressly approved by the party responsible for compliance could void the user's authority to operate the equipment.

IMPORTANT NOTE: To comply with the FCC RF exposure compliance requirements, the antenna(s) used for this transmitter must be installed to provide a separation distance of at least 20 cm from all persons and must not be co-located or operating in conjunction with any other antenna or transmitter. No change to the antenna or the device is permitted. Any change to the antenna or the device could result in the device exceeding the RF exposure requirements and void user's authority to operate the device.