

Wireless Lock Controller User's Manual

Product Name: **Wireless Lock Controller**

Model No: **WLC-110**

Input Power: **12V DC**

Features Description:

1. WR-110 (Wireless repeater) use wireless way to dispatch signal to WLC-110 (Wireless Lock Controller) which can open the lock and send back the state of open to repeater
2. Framework of WLC-110 (Wireless Lock Controller) is one for DO output and two for DI input interface.
3. WLC-110(Wireless Lock Controller) needs to collocate with lock equipment for 12V DC Power.
4. It is east to link with Gateway. Lock equipment and lock controller wires link together. Then need to press the back of setting button and Binding with repeater.
5. Be able to use cell phone to control and open the door. That provides more convenience for user.

Outline Dimensions:



Feature Locator:

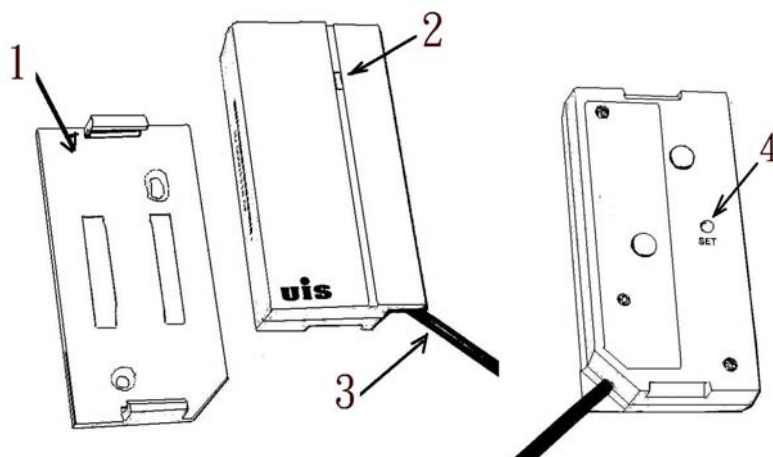

1. Foundation stop plate
2. State of LED window
3. Outlet wires
4. (SET) Setting button

Installation Hints:

1. Circuit of lock equipment needs to link with WLC-110 (Wireless lock controller) that is able to use.
2. Such as collocation with SL-130B lock equipment. Illustration of circuit is as below.:

SL-130B ALL PURPOSE TYPE DEADBOLT LOCK

✧Connections

Model Color	6-PIN (SL-130A/SL-130B)	Type	Model Color	3-PIN (SL-130B Only)
Brown	GND	Fail secure	Purple	Lock Position Sensor (N.C.)
Red	+DC12V		Gray	Lock Position Sensor (COM)
Orange	Push Button		Black	Lock Position Sensor (N.O.)
Yellow	Door Position Sensor (N.C.)	Fail safe	Purple	Lock Position Sensor (N.O.)
Green	Door Position Sensor (COM)		Gray	Lock Position Sensor (COM)
Bule	Door Position Sensor (N.O.)		Black	Lock Position Sensor (N.C.)

✧Wiring Diagram

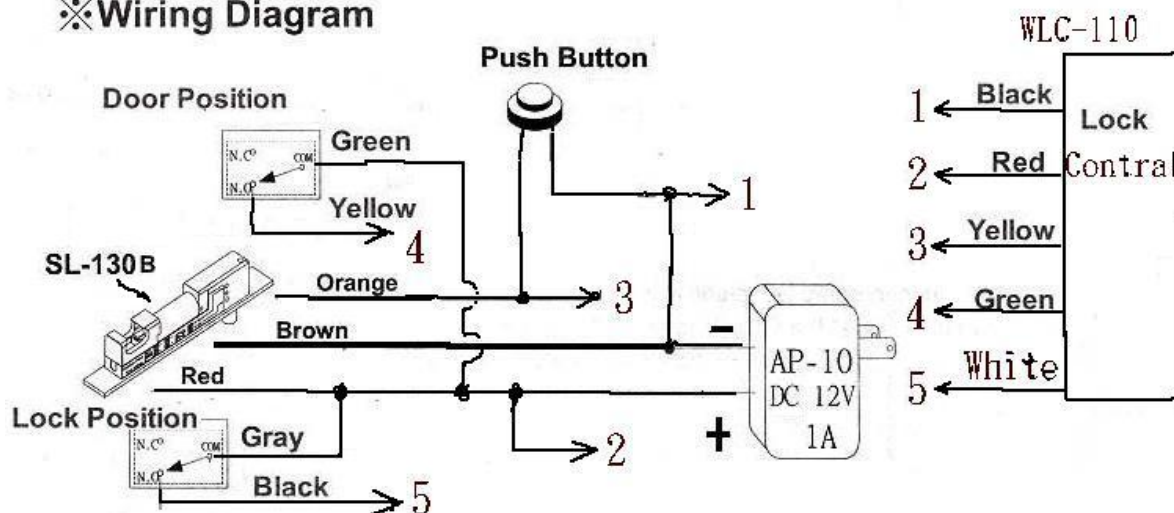

3. WLC-110 (Wireless lock controller) has five wires, color wire function as below.
 - a. Black wire Power input 0V(negative)
 - b. Red wire Power input 12V(positive)
 - c. Yellow wire Lock open control output
 - d. Green wire Door Position status input
 - e. White wire Lock Position status input
4. To provide 12V power supply to WLC-110 (Wireless lock controller) and press the setting button of the bottom. Then press the setting button of WR-110 (Wireless repeater) bottom. Wait for 30 seconds to 1 minute. If LED indicator light flash three times that means linking success. If LED indicator light flash two times that means fail.
5. Join to link with Gateway, please reference user manual of WCC-110 (Wireless console controller).
6. If WLC-110 (Wireless lock controller) would like to confirm the function alone, circuit of external linking way is as below.

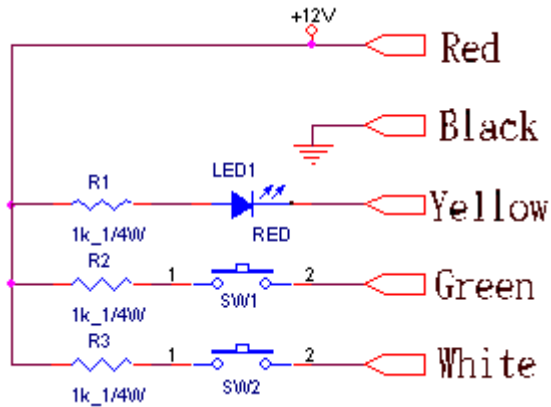

Troubleshooting:

Problem: When link with WR-110 (Wireless repeater), there is no display of LED indicator light for WLC-110 (Wireless lock controller) to flash two or three times.

- Solution:**
- Need to confirm with circuit of lock controller whether it is good and there is power for 12V DC.
 - May be not press set button, need to link with repeater again.
 - If the above handles are invalid, please contact with agency.

Problem: Unable to link with WR-110 (wireless repeater).

- Solution:**
- It needs to confirm the distance between WLC-110 (Wireless lock controller) and WR-110 (Wireless repeater). Wireless connects in non-camouflage straight line effective range 10 meters. May pull closer between both distance tests to have a look first, whether to have the improvement segment condition.

Specification:

Wireless Lock Controller	
Model No.	WLC-110
Electrical Specification	
Transmit Frequency	2.4GHz
Modulation	GFSK
Transmit Power	0 dBm
Channel spacing	1 MHz
Channel NO.	81 Channel(2401 ~ 2481Mhz)
Range of operation	10 meters
Operating voltage	12V DC
Current (typical)	20mA Max.
Input Signal	Dry Connect *2
Output Signal	15V 120mA Max.
Display Type	Red LED indicator
Operation Interface	Push button switch for setting
Environmental Requirement	
Operating temperature	-20°C to 60°C
Storage temperature	-20°C to 70°C
Humidity	90% RH Max. Non-Condensing
Mechanical Specification	
Dimension (WxHxD, mm)	40x80x22
Weight	40g
Pin Assignment	
Pin 1- (Red)	DC +12V Power Input
Pin 2- (Black)	Common
Pin 3- (Yellow)	Open Collect Digital Output
Pin 4- (Green) -- Door open/close status	0V,12V DC Level input (active high)
Pin 5- (White)-- Lock/unlock status	0V,12V DC Level input (active high)

FEDERAL COMMUNICATIONS COMMISSION INTERFERENCE STATEMENT

This equipment has been tested and found to comply with the limits for a Class B digital device, pursuant to Part 15 of the FCC Rules. These limits are designed to provide reasonable protection against harmful interference in a residential installation. This equipment generates, uses and can radiate radio frequency energy and, if not installed and used in accordance with the instructions, may cause harmful interference to radio communications. However, there is no guarantee that interference will not occur in a particular installation. If this equipment does cause harmful interference to radio or television reception, which can be determined by turning the equipment off and on, the user is encouraged to try to correct the interference by one or more of the following measures:

- Reorient or relocate the receiving antenna.
- Increase the separation between the equipment and receiver.
- Connect the equipment into an outlet on a circuit different from that to which the receiver is connected.
- Consult the dealer or an experienced radio/TV technician for help.

CAUTION:

Any changes or modifications not expressly approved by the party responsible for compliance could void the user's authority to operate the equipment.

This device complies with Part 15 of the FCC Rules. Operation is subject to the following two conditions:

- (1) This device may not cause harmful interference and
- (2) This device must accept any interference received, including interference that may cause undesired operation.

Canada Warning

"Industry Canada regulatory information Operation is subject to the following two conditions: (1) this device may not cause interference, and (2) this device must accept any interference, including interference that may cause undesired operation of the device." "The user is cautioned that this device should be used only as specified within this manual to meet RF exposure requirements. Use of this device in a manner inconsistent with this manual could lead to excessive RF exposure conditions."