

Jasco Z-Wave Remote Control Model 45600

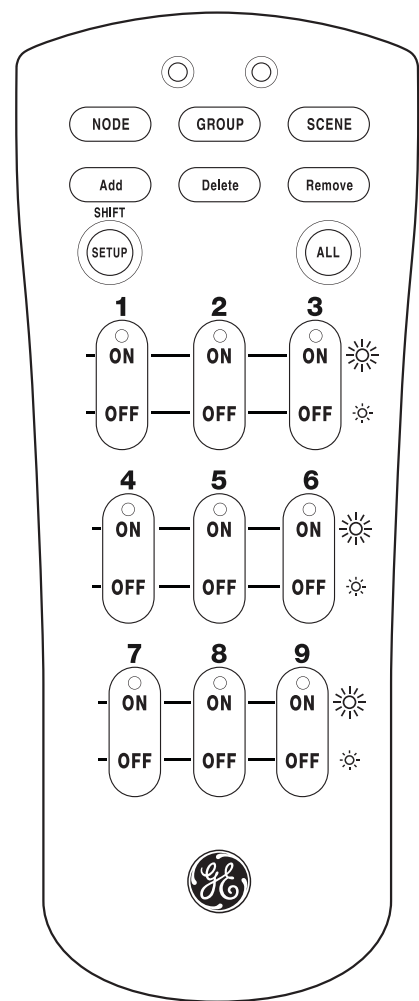

USER GUIDE

INTRODUCTION

Thank you for purchasing a Jasco Z-wave Remote. Your remote lets you control up to 18 individual Z-wave devices with one easy-to-use, compact unit. You can also set up and control up to 18 different groups and scenes. Each group can include up to 232 Z-Wave nodes and each scene can include up to 32 nodes.

You can control your electric lights, turning them on or off, or making them brighter or dimmer.

After installing batteries (see next section), you must use the Jasco Z-wave remote to create your control network.

For best results, please read and perform all the remaining instructions. Also, keep this guide for future reference.

INSTALLING BATTERIES

Your Jasco Z-wave Remote requires three AAA batteries (not supplied) for power.

Battery Use And Safety

- Use only fresh batteries of the required size and recommended type.
- Do not mix old and new batteries, different types of batteries (that is, standard, alkaline, or rechargeable), or rechargeable batteries of different capacities.

CAUTION: If you do not plan to use the remote for an extended period, remove the batteries. They can leak

chemicals that can destroy electronic parts.

WARNING: Dispose of old batteries promptly and properly. Do not burn or bury them.

To Install Batteries:

- Open the battery compartment cover (located on the back of the remote).
- Place the AAA batteries in the compartment and match the + and - polarity symbols inside.
- Replace the cover.

NOTE: When the red LED on the Jasco Z-wave Remote starts to blink 5 times after a key press, you must replace the batteries. The remote retains all its user settings while replacing the batteries.

A QUICK LOOK AT THE CONTROLS

Press this key...	To...
	Program sequences.
	Use SHIFT to enter numbers higher than 9 on the numeric keypad (e.g., SHIFT 1 for 10 or SHIFT 9 for 18).
	Turn the selected node on or off. Also, adjust the brightness of a node, group, or scene.
	Control the selected node.
	Control the selected group.
	Control the selected scene.
	Add a group, node, or scene to control.
	Delete a group, node, or scene.

	Turn the selected node on or off. Also, adjust the brightness of a node, group, or scene.
	Control the selected node.
	Control the selected group.
	Control the selected scene.
	Add a group, node, or scene to control.
	Delete a group, node, or scene.

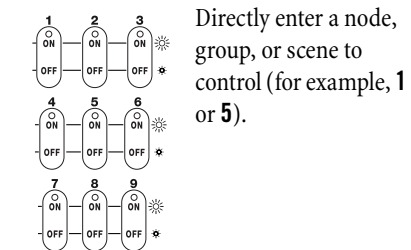

ADDING A NODE TO THE NETWORK

The Jasco Z-wave Remote allows you to control lights around your home. In order to control the lights, they must be Z-wave compatible and you must first add them to your home network. To add a node to your home network, perform the following steps:

- Press and hold **SETUP** until both the red and green LEDs blink twice.
- Press **ADD** once.
- Press **NODE** once.

- Press **NODE** again.
- Press the button on the node so that it sends its information to the remote and receives information from the remote.
- The green LED blinks twice. You have successfully added the node to your home network.

NOTE: If the red LED emits one long, steady blink, you have pressed an invalid key or the node has not been successfully added the node to your home network. Please make sure the remote is close to the node and try again.

ADDING A NODE TO YOUR REMOTE

You can add a node to your remote control so that it can control an individual node. Adding a node to your remote also adds it to your network. If the node number you are trying to add is already associated with another node, the previous node information is lost.

To add a node to your remote, perform the following steps:

- Press and hold **SETUP** until both the red and green LEDs blink twice.
- Press **ADD** once.
- Press **NODE** once.
- Press a digit (1-9) for the node location you wish to add. Press **SHIFT** and the digit (1-9) if you are adding nodes 10 through 18.
- Press the button on the node so that it sends its information to the remote and receives information from the remote.
- The green LED blinks twice. You have successfully added the node to your remote control.

NOTE: If the red LED emits one long, steady blink, you have pressed an invalid key or the node has not been successfully added to your remote. Please make sure the remote is close to the node and try again.

REMOVING AN INDIVIDUAL NODE FROM YOUR REMOTE (DISASSOCIATING FROM REMOTE)

- Press and hold **SETUP** until both the red and green LEDs blink twice.
- Press **REMOVE** once.
- Press **NODE** once.
- Press a digit (1-9) for the node location you wish to remove. Press **SHIFT** and the digit (1-9) if you are adding nodes 10 through 18.
- The green LED blinks twice. You have successfully removed the node from your remote control.

NOTE: If the red LED emits one long, steady blink, you have pressed an invalid key or the node has not been successfully removed from your remote control.

DELETING A NODE FROM YOUR NETWORK

To remove a node from your home network, you must delete it from the network. To delete the node from your network, perform the following steps:

- Press and hold **SETUP** until both the red and green LEDs blink twice.
- Press **DELETE** once.

- Press **NODE** once.
- Press the button on the node so that it sends its information to the remote and receives information from the remote.
- The green LED blinks twice. You have successfully deleted the node from your home network.

NOTE: If the red LED emits one long, steady blink, you have pressed an invalid key or the node has not been successfully deleted from your home network.

CONTROLLING NODES

You can control a node to turn it on or off, or change its brightness level. The operation of a specific node varies by product. Refer to the manual for that node to learn its specific operation.

Turning a Node On or Off (Assuming the user is in the Node mode already)

- To turn a node on, press and release the **ON** key for more than one second. The green LED blinks once.
- To turn a node off, press and release the **OFF** key for less than one second. The green LED blinks once.

Setting a Node's Brightness Level

- To make a node brighter, press and hold the **ON** key for more than one second. The green LED blinks once.
- To make a node dimmer, press and hold the **OFF** key for more than one second. The green LED blinks once.

NOTE: If the red LED emits one long, steady blink the remote has not successfully communicated with the node.

SETTING UP AND CONTROLLING A GROUP

You can create a collection of nodes that you can control as a group. You can set up a maximum of 18 groups. Each group can contain up to 232 nodes.

Adding a Node to a Group

To add a node to a group, perform the following steps:

- Press and hold **SETUP** until both the red and green LEDs blink twice.
- Press **ADD** once.
- Press **GROUP** once.
- Press a digit (1-9) for group you wish to add the node to. Press **SHIFT** and the digit (1-9) if you are adding nodes 10 through 18.
- Put the node into programming mode, so that it sends its information to the remote and receives information from the remote.
- The green LED blinks twice. You have successfully added the node to your group.

NOTE: If the red LED emits one long, steady blink, you have pressed an invalid key or the node has not been successfully added to your group.

Removing a Node from a Group

- Press and hold **SETUP** until both the red and green LEDs blink twice.
- Press **REMOVE** once.
- Press **GROUP** once.
- Press a digit (1-9) for the group you wish to remove the node from. Press **SHIFT** and the digit (1-9) if you are removing nodes 10 through 18.

- Press the button on the node you wish to remove.
- The green LED blinks twice. You have successfully removed the node from your group.

NOTE: If the red LED emits one long, steady blink, you have pressed an invalid key or the node has not been successfully removed from your group.

Deleting a Group

- Press and hold **SETUP** until both the red and green LEDs blink twice.
- Press **DELETE** once.
- Press **GROUP** once.
- Press a digit (1-9) for the group you wish to delete. Press **SHIFT** and the digit (1-9) if you are deleting groups 10 through 18.
- The green LED blinks twice. You have successfully deleted the group from your home network.

NOTE: If the red LED emits one long, steady blink, you have pressed an invalid key or the group has not been successfully removed from your home network.

SETTING UP SCENES

A scene is a single node or group of nodes that can be preset to turn to a previously specified setting (brightness level). You can set up a maximum of 18 scenes, containing up to 32 Nodes per scene.

Adding a Node to a Scene

- Press and hold **SETUP** until both the red and green LEDs blink twice.
- Press **ADD** once.
- Press **SCENE** once.
- Press a digit (1-9) for the scene you wish to add the node to. Press **SHIFT** and the digit (1-9) if you are adding nodes to scenes 10 through 18.
- Press the button on the node that you are adding. Adjust the brightness on the actual node within 30 seconds (refer to the manual for the node).

The green and red LEDs blink rapidly, indicating the remote is pending the setup of the bright/dim setting on the node.

- Press **SCENE**. The green and red LEDs stop blinking.
- The green LED blinks twice. You have successfully added the node to a scene.

NOTE: If the red LED emits one long, steady blink, you have pressed an invalid key or the node has not been successfully added to the scene.

Removing a Node from a Scene

- Press and hold **SETUP** until both the red and green LEDs blink twice.
- Press **REMOVE** once.
- Press **SCENE** once.
- Press a digit (1-9) for the node location you wish to remove. Press **SHIFT** and the digit (1-9) if you are removing nodes 10 through 18.
- Press the button on the node that you wish to remove.
- The green LED blinks twice. You have successfully removed the node from the scene.

NOTE: If the red LED emits one long, steady blink, you have pressed an invalid key or the node has not been successfully removed from the scene.

Deleting a Scene

- Press and hold **SETUP** until both the red and green LEDs blink twice.
- Press **DELETE** once.
- Press **SCENE** once.
- Press a digit (1-9) for the scene you wish to remove. Press **SHIFT** and the digit (1-9) if you are removing nodes 10 through 18.
- The green LED blinks twice. You have successfully deleted the scene from your home network.

NOTE: If the red LED emits one long, steady blink, you have pressed an invalid key or the scene has not been successfully deleted.

CONTROLLING SCENES

To control a scene, perform the following steps:

- Press **SCENE** once.
- Press the digit key for the scene you wish to control (1-9). Press **SHIFT** and the digit (1-9) if you are controlling nodes 10 through 18. The green LED blinks once.

NOTE: If the red LED emits one long, steady blink, the remote has not successfully communicated with the node.

Turning All Nodes On or Off

To turn all nodes either on or off, perform the following steps:

- Press **ALL** once.
- Press either **ON** to turn the nodes on, or **OFF** to turn the nodes off. Any **ON** or **OFF** can be pressed. The green LED blinks once.

NOTE: If the red LED emits one long, steady blink, you have pressed an invalid key or the All-On/All-Off command was not successful. Repeat the steps above to try again.

The factory default setting for GE Z-Wave devices is to be included in All-On and All-Off control. The following section on "Adding Nodes to All Control" should only be needed if the node has previously been deleted from All Control.

Adding Nodes to All Control

- Press and hold **SETUP** until both the red and green LEDs blink twice.
- Press **ADD** once.
- Press **ALL** once.
- Press the button on the node you wish to include.
- The green LED blinks twice. You have successfully added the node to All Control.

NOTE: If the red LED emits one long, steady blink, the node has not been successfully added to the group.

Deleting Nodes from All Control

- Press and hold **SETUP** until both the red and green LEDs blink twice.
- Press **DELETE** once.
- Press **ALL** once.
- Press the button on the node that you wish to remove from All Control.
- The green LED blinks twice. You have successfully deleted the node from All Control.

NOTE: If the red LED emits one long, steady blink, the node has not been successfully deleted from the group.

TRANSFERRING NODE AND NETWORK INFORMATION TO A SECONDARY REMOTE

You can add a secondary remote to your network, and transfer your primary remote's node and network information to it. To transfer node and network information to a secondary remote, perform the following steps:

- Place the two remotes near each other.
- Press and hold **SETUP** until both the red and green LEDs blink twice.
- Enter **9 6 6 1** on the numeric keypad.
- Put the target (secondary) remote into programming mode so that it sends its information to the primary remote, as well as receives information from the remote. The remote then transfers the network and node information to the new secondary remote. Refer to the user manual for the secondary remote for more information.
- The green LED blinks twice. You have successfully transferred the information.

NOTE: If the red LED emits one long, steady blink, the information has not been successfully transferred.

Add nodes, groups, and scenes to the new secondary remote as needed.

TRANSFERRING NETWORK INFORMATION TO A SECONDARY REMOTE

You can add a secondary remote to your network, and transfer your primary remote's network information to it. To transfer network information to a secondary remote, perform the following steps:

- Place the two remotes near each other.
- Press and hold **SETUP** until both the red and green LEDs blink twice.
- Enter **9 6 6 2** on the numeric keypad.
- Put the target (secondary) remote into programming mode so that it sends its information to the primary remote, as well as receives information from the remote. The remote then transfers the network and node information to the new secondary remote. Refer to the user manual for the secondary remote for more information.
- The green LED blinks twice. You have successfully transferred the information.

NOTE: If the red LED emits one long, steady blink, the information has not been successfully transferred.

PRIMARY CONTROLLER SHIFT

You can transfer all of your remote's information to another remote, so it becomes the new primary remote. You can do this in two ways: either transferring all information, or just transferring network information.

Transferring All Network and Remote Information

- Place the two remotes near each other.
- Press and hold **SETUP** until both the red and green LEDs blink twice.
- Enter **9 6 8 1** on the numeric keypad.

- Put the target (new primary) remote into programming mode so that it sends its information to the primary remote, as well as receives information from the remote. The remote then transfers the network and node information to the new primary remote. Refer to the user manual for the new primary remote for more information.
- The green LED blinks twice. You have successfully transferred the information.

NOTE: If the red LED emits one long, steady blink, the information has not been successfully transferred.

Transferring Only Network Information

- Place the two remotes near each other.
- Press and hold **SETUP** until both the red and green LEDs blink twice.
- Enter **9 6 8 2** on the numeric keypad.
- Put the target (new primary) remote into programming mode so that it sends its information to the primary remote, as well as receives information from the remote. The remote then transfers the network information to the new primary remote. Refer to the user manual for the new primary remote for more information.
- The green LED blinks twice. You have successfully transferred the information.

NOTE: If the red LED emits one long, steady blink, the information has not been successfully transferred.

Add nodes, groups, and scenes to the new primary remote as needed.

USING CONTROLLER COPY RECEIPT

Controller copy receipt allows the remote to receive information from another remote. This allows the unit that received the information to become a new primary or secondary remote.

- Place the two remotes near each other.
- Press and hold **SETUP** until both the red and green LEDs blink twice.
- Enter **9 6 7** on the numeric keypad.
- Put the target remote into programming mode so that it sends its information to the Jasco 45600 remote, as well as receives information from the remote.
- The green LED blinks twice. You have successfully transferred the information.

NOTE: If the red LED emits one long, steady blink, the information has not been successfully transferred.

Add nodes, groups, and scenes to the new remote as needed

RECOVERING NETWORK INFORMATION

To have your remote recover network information, perform the following steps:

- Press and hold **SETUP** until both the red and green LEDs blink twice.
- Enter **9 6 1** on the numeric keypad.
- The green LED blinks twice. You have successfully recovered network information.

NOTE: If the red LED emits one long, steady blink, the information has not been successfully recovered.

RESTORING YOUR REMOTE TO MANUFACTURER'S SETTINGS

To restore your remote to its original manufacturer's settings, perform the following steps:

- Press and hold **SETUP** until both the red and green LEDs blink twice.
- Enter **9 8 1** on the numeric keypad.
- The green LED blinks twice. You have successfully recovered network information.

NOTE: If the red LED emits one long, steady blink, the remote's settings have not been successfully restored.

RESETTING YOUR NETWORK

You can reset your network to clear all node and Z-wave network information. To reset your network, perform the following steps:

- Press and hold **SETUP** until both the red and green LEDs blink twice.
- Enter **9 6 9** on the numeric keypad.
- The green LED blinks twice. You have successfully reset network information.

NOTE: If the red LED emits one long, steady blink, the network has not been successfully reset.

FCC NOTICE

This equipment has been tested and found to comply with the limits for a class B digital device, pursuant to part 15 of the FCC Rules. These limits are designed to provide reasonable protection against harmful interference in a residential installation. This equipment generates, uses and can radiate radio frequency energy and if not installed and used in accordance with the instructions, may cause harmful interference to radio communications.

However, there is no guarantee that interference will not occur in a particular installation. If this equipment does cause harmful interference to radio or television reception, which can be determined by turning the equipment off and on, the user is encouraged to try to correct the interference by one or more of the following measures:

- Reorient or relocate the receiving antenna.
- Increase the separation between the equipment and receiver.
- Connect the equipment into an outlet on a circuit different from that to which the receiver is connected.
- Consult the dealer or an experienced radio/TV technician for help.

This equipment has been verified to comply with the limits for a class B computing device, pursuant to FCC Rules. In order to maintain compliance with FCC regulations, shielded cables must be used with this equipment. Operation with non-approved equipment or unshielded cables is likely to result in interference to radio and TV reception. The user is cautioned that changes and modifications made to the equipment without the approval of manufacturer could void the user's authority to operate this equipment.

FCC ID: MG345600