

Doc. Title	UNA Plus/ UNA-Lite Function EVB User Guide
Originator	Max Shu
Date	2013.10.29
Version	V1.2

Product Line	UMD (MPC)
Doc. NO.	
CONFIDENTIAL	<input type="checkbox"/> Low <input checked="" type="checkbox"/> Normal <input type="checkbox"/> High

Revision Record

Version	Revise content	Date
1.1	Initial Release	2013.06.06

Category

1. FCC Regulations	3
2. R&TTE Regulations	4
3. RF Exposure Information.....	5
4. Information of Installed Module.....	6
5. Illustration of Function EVB.....	7
6. General Mode	9
6-1 Setting of Jumpers & Switches	9
7. Settings for Download /Update Mode.....	14
8. Advance Mode	15
8-1 Module on/off Control.....	15
8-2 Voltage Settings	15
8-3 Use External Power Supplier	16
8-4 Current Measurement.....	17
8-5 Settings for Slide-Style Switch (J42).....	17
8-6 PCM Signal	18
8-6-1 PCM Signal Port (J24).....	18
8-6-2 PCM Loop Settings.....	19
8-6-3 External I ² C Interface to Control Audio Codec	20
8-7 UART0 & UART1 Signal Port (J23)	21
8-8 Wakeup Control	22
8-8-1 USB Mode	22
8-8-2 USB+UART Mode	23

1. FCC Regulations

- This device complies with part 15 of the FCC Rules. Operation is subject to the following two conditions: (1) This device may not cause harmful interference, and (2) this device must accept any interference received, including interference that may cause undesired operation.

- This device has been tested and found to comply with the limits for a Class B digital device, pursuant to Part 15 of the FCC Rules. These limits are designed to provide reasonable protection against harmful interference in a residential installation. This equipment generates, uses and can radiated radio frequency energy and, if not installed and used in accordance with the instructions, may cause harmful interference to radio communications. However, there is no guarantee that interference will not occur in a particular installation. If this equipment does cause harmful interference to radio or television reception, which can be determined by turning the equipment off and on, the user is encouraged to try to correct the interference by one or more of the following measures:
 - Reorient or relocate the receiving antenna.
 - Increase the separation between the equipment and receiver.
 - Connect the equipment into an outlet on a circuit different from that to which the receiver is connected.
 - Consult the dealer or an experienced radio/TV technician for help.

The maximum antenna gain for frequency 900 is 2 dBi; for frequency 1800 is 2 dBi ;and the antenna separation distance is 20cm.

Maximum antenna gain allowed for use with this device is 2 dBi.

Telefication

CE 0560

Changes or modifications not expressly approved by the party responsible for compliance could void the user's authority to operate the equipment.

2. R&TTE Regulations

In all cases assessment of the final product must be mass against the Essential requirements of the R&TTE Directive Articles 3.1(a) and (b), safety and EMC respectively, as well as any relevant Article 3.3 requirements.

1. Health (Article 3.1(a) of the R&TTE Directive)

Applied Standard(s):

EN62311:2008

2. Safety (Article 3.1(a) of the R&TTE Directive)

Applied Standard(s):

EN 60950-1:2006/A11:2009/A1:2010/A12:2011

3. Electromagnetic compatibility (Article 3.1 (b) of the R&TTE Directive)

Applied Standard(s):

EN 301 489-1 V1.9.2/-7 V1.3.1/-24 V1.5.1

4. Radio frequency spectrum usage (Article 3.2 of the R&TTE Directive)

Applied Standard(s):

EN 301 511 V9.0.2

EN 301 908-1 V5.2.1/ -2 V5.2.1

3. RF Exposure Information

Radiation Exposure Statement:

This equipment complies with FCC radiation exposure limits set forth for an uncontrolled environment. This equipment should be installed and operated with minimum distance 20cm between the radiator & your body.

This device is intended only for OEM integrators under the following conditions:

- 1) The antenna must be installed such that 20 cm is maintained between the antenna and users, and the maximum antenna gain allowed for use with this device is 2dBi.
- 2) The transmitter module may not be co-located with any other transmitter or antenna.

As long as 2 conditions above are met, further transmitter test will not be required. However, the OEM integrator is still responsible for testing their end-product for any additional compliance requirements required with this module installed

IMPORTANT NOTE: In the event that these conditions can not be met (for example certain laptop configurations or co-location with another transmitter), then the FCC authorization is no longer considered valid and the FCC ID can not be used on the final product. In these circumstances, the OEM integrator will be responsible for re-evaluating the end product (including the transmitter) and obtaining a separate FCC authorization.

End Product Labeling

This transmitter module is authorized only for use in device where the antenna may be installed such that 20 cm may be maintained between the antenna and users. The final end product must be labeled in a visible area with the following: **“Contains FCC ID: IXM-UNA-P3”**. The grantee's FCC ID can be used only when all FCC compliance requirements are met.

Manual Information To the End User

The OEM integrator has to be aware not to provide information to the end user regarding how to install or remove this RF module in the user's manual of the end product which integrates this module.

The end user manual shall include all required regulatory information/warning as show in this manual.

4. Information of Installed Module

Module Name	UNA-P3/UNA-L3
HW Version	V21
SW Version	V2.4.00101
GSM Band	850, 900, 1800, 1900
UMTS Band	FDD I, FDD II, FDD V
GSM Feature	R99
GPRS	Class 12
EDGE	Class 12
UMTS Feature	HSDPA, HSUPA,HSPA+(R7)
AT Command	3GPP TS 27.007, 27.005
SIM/USIM	Support 3V and 1.8V
Interface	USB 2.0 high speed
Operating Temperature	Frequency Stability covers operating temperature range of -20° to +50°C
Operating Voltage	3.4 ~ 4.2V

User Guide for UNA PLUS Function EVB

5. Illustration of Function EVB

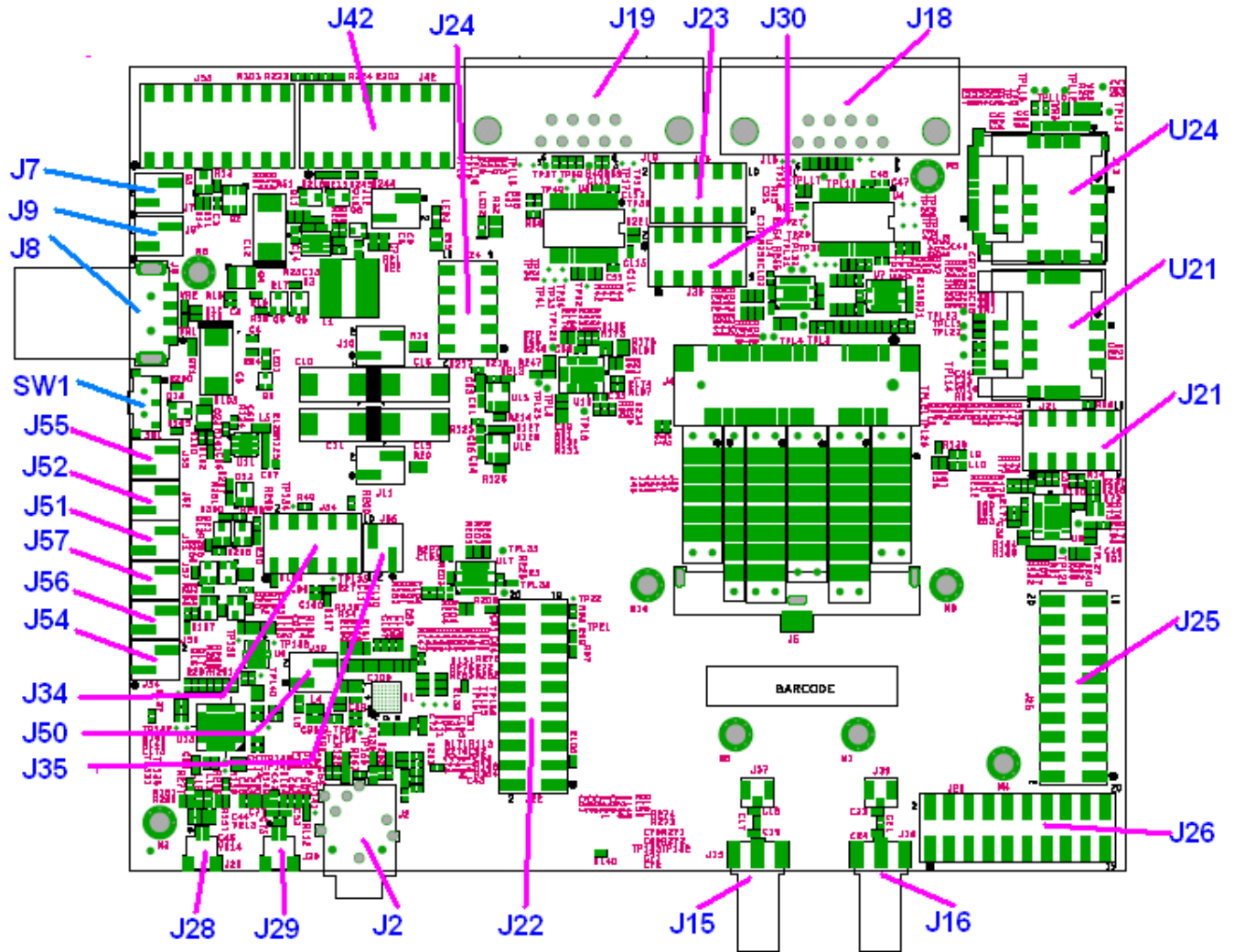

Figure. Layout of Function EVB

Reference	Type	Description	Support	Non-Support
J8	USB Conn.	Connect host PC or download firmware	V	
J7	Pin Header	Select external power supplier (+) (Default is 'Open'.)	V	
J9	Pin Header	Select external power supply (-) (Default is 'Open'.)	V	
SW1	On/off switch	Module on/off control	V	
J55	Pin Header	Module on/off control (Default is 'Open'.)	V	
J15	Ant. Conn.	Main antenna SMA Connector	V	
J16	Ant. Conn.	AUX antenna SMA Connector	V	
U24	SIM 1 Conn.	Connect SIM Card	V	
U21	SIM 2 Conn.	Connect SIM Card		V
J18	COM port 0	Debug Pin	V	
J19	COM port 1	Transmit/ Receive AT Command.	V	
J21	Pin Header	Factory Test (Default is 'Open'.)		V
J23	Pin Header	UART0 & UART1 signal connector (Default is 'Open'.)	V	
J30	Pin Header	Factory Test (Default is 'Open'.)	V	
J24	Pin Header	PCM signal connector (Default is 'Open'.)	V	
J56	Pin Header	Wake up AP in AP sleep mode (wake up AP) (Default is 'Open'.)	V	
J54	Pin Header	Wake up module in module sleep mode (wake up modem) (Default is 'Open'.)	V	
J2	Headset Conn.	EAR PHONE & MIC		V
J28	Audio Conn.	Audio LINE-OUT		V
J29	Audio Conn.	Audio LINE-IN		V
J42	Switch Conn.	Slide-Style Switch.	V	
J52	Pin Header	Factory Test (Default is 'Open'.)		V
J51	Pin Header	Factory Test (Default is 'Open'.)		V
J57	Pin Header	Factory Test (Default is 'Open'.)		V
J34	Pin Header	Factory Test (Default is 'Open'.)		V
J35	Pin Header	Factory Test (Default is 'Open'.)		V
J50	Pin Header	Factory Test (Default is 'Open'.)		V
J22	Pin Header	Factory Test (Default is 'Open'.)		V
J25	Pin Header	Factory Test (Default is 'Open'.)		V
J26	Pin Header	Factory Test (Default is 'Open'.)		V

6. General Mode

6-1 Setting of Jumpers & Switches

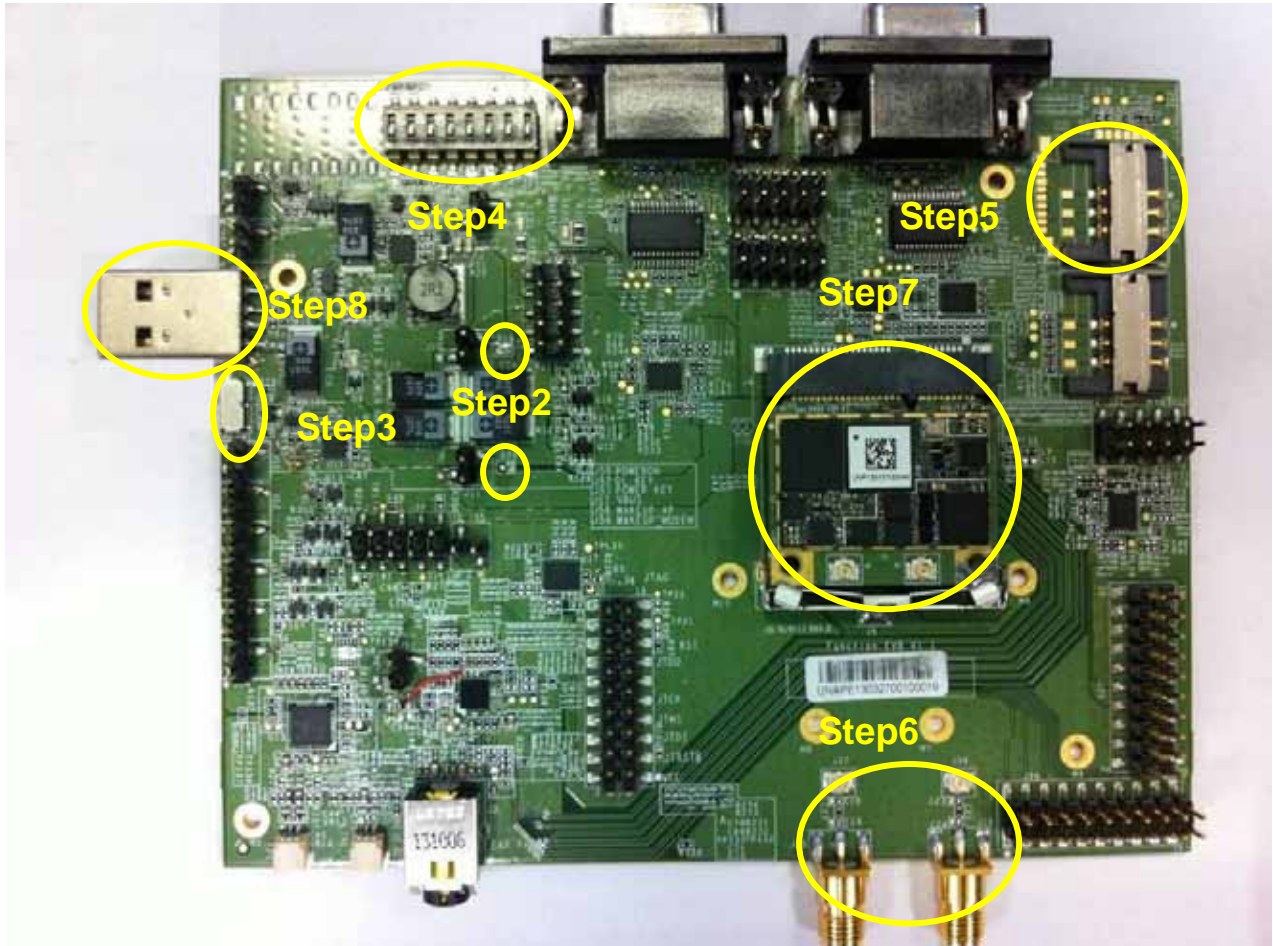

Figure. Settings of general mode

Step1. Remove every jumper on the board.

Step2. Keep 'R19' and 'R20' short.

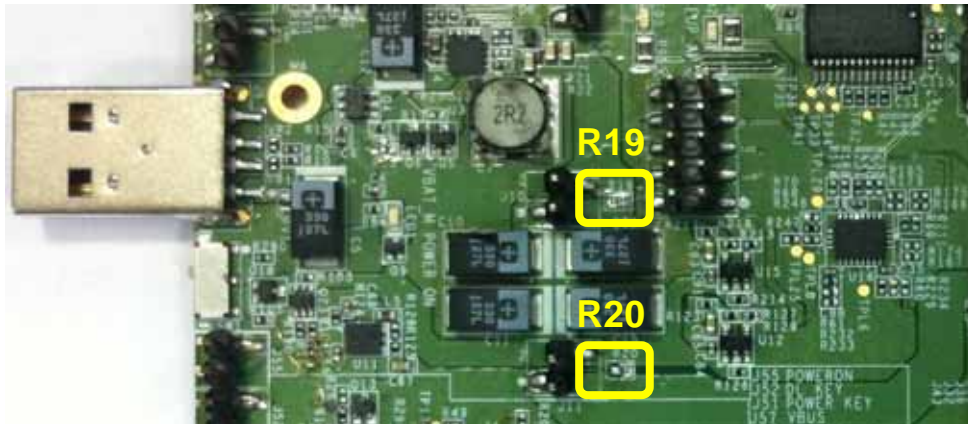

Figure. Keep 'R19' and 'R20' short.

Step3. For 'SW1', select 1-2. (Upper position)

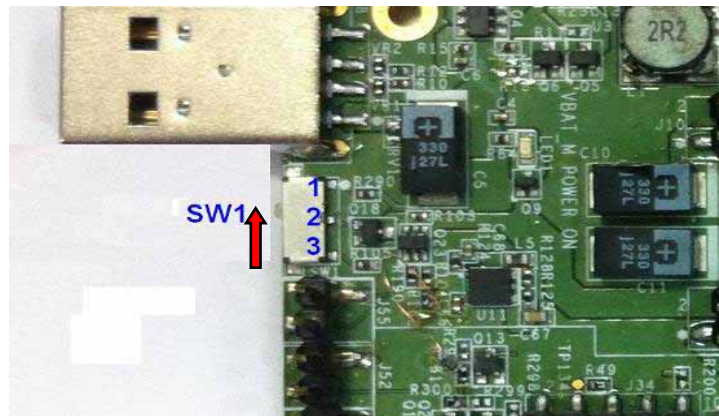

Figure. For 'SW1', select 1-2.

Step4. For 'J42', eight switches should be in 'OFF' position.

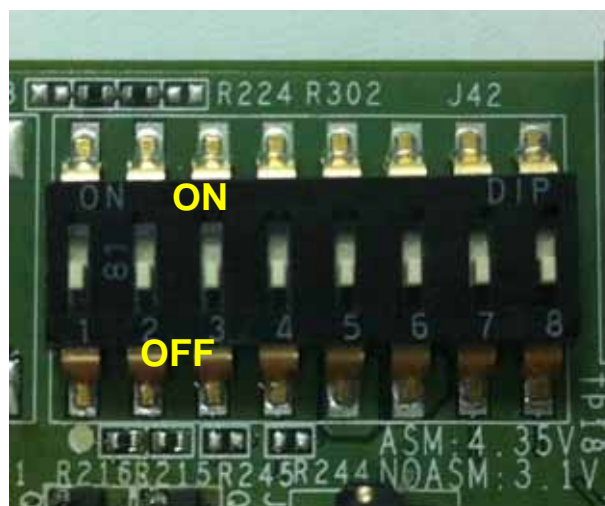

Figure. Switches in 'OFF' position.

Step5. Insert SIM card.

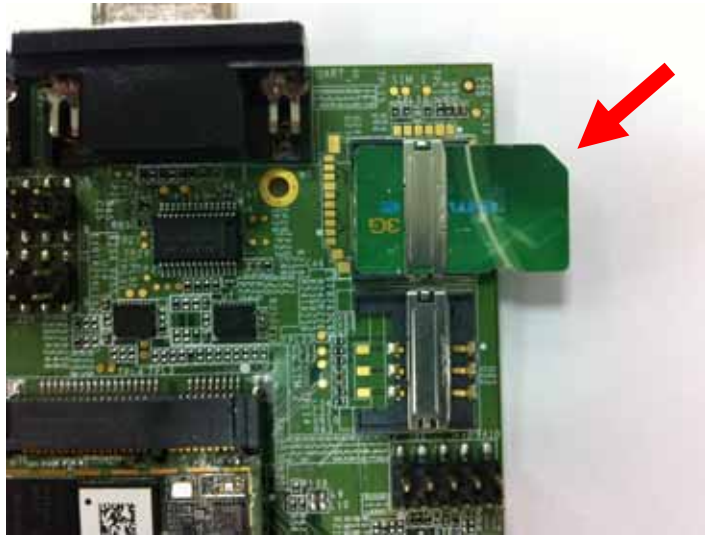

Figure. Insert correctly SIM card.

Step6. Set up Antenna.

a. Connect bottom of mini card by U.FL cable as following photo.



Figure. Connect by U.FL cable.

b. Connect EVB and mini card by U.FL cable. Put mini card on EVB.



Figure. Connect mini card and EVB.

b. Connect SMA antenna.



Figure. Connect antenna.

Step7. Set up Module.

a. By 30 degree angle, lean mini card and insert it on the socket, J4.



Figure. Insert mini card.

b. Press mini card until it is stuck by connector, J5.



Figure. Mini card is stuck.

Step8. Connect computer by USB cable.

Recommended USB cable length is less than 60 mm.



Figure. Connect PC by USB cable.

7. Settings for Download /Update Mode

Component reference	Open/Short	Function
Pin17-18 in J25	Open	Close Download/Update mode
	Short	Start Download/Update mode

Step1. Put back the jumper in J25 to short its Pin.17, Pin.18.



Figure. Put back jumper.

Step2. Connect EVB and computer by USB cable.



Figure. Connect PC.

Step3. About SW part, please refer to the file, [‘UNA PLUS Flash Tool User Guide’](#).

8. Advance Mode

8-1 Module on/off Control

a. Method 1. Module Control by SW1.

Component reference	Function	SW1,1-2	SW1,2-3
SW1	Control Module	Turn on (Default)	Turn off

PS2. Please remove the Jump, J55, at first.

b. Method 2. Module Control by J55.

Component reference	Open/Short	Function
J55	Open	Shut down (Default)
	Short	Turn on

PS3. Please select 2-3 for SW1 at first. (Lower position)

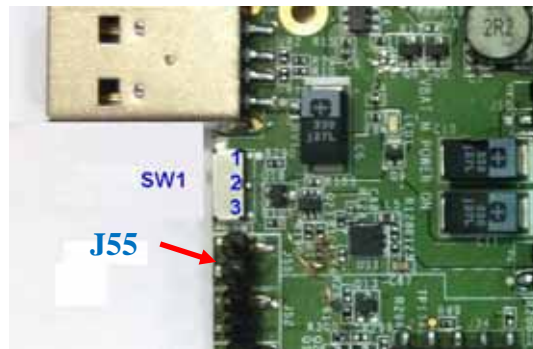

Figure. J55 & SW1

8-2 Voltage Settings

Component reference	Open/Short	Function
J12	Open	Supply 3.3Volt to 3G Module. (Default)
	Short	Supply 4.35Volt to 3G Module.

8-3 Use External Power Supplier

Please follow the steps as below.

Step1. Remove the jumper, J10 and clear solder on R19.

Step2. Connect host PC by USB cable.

Step3. J7 is power input, and voltage range is from 3.3V to 4.3V.

Step4. J9 is GND.

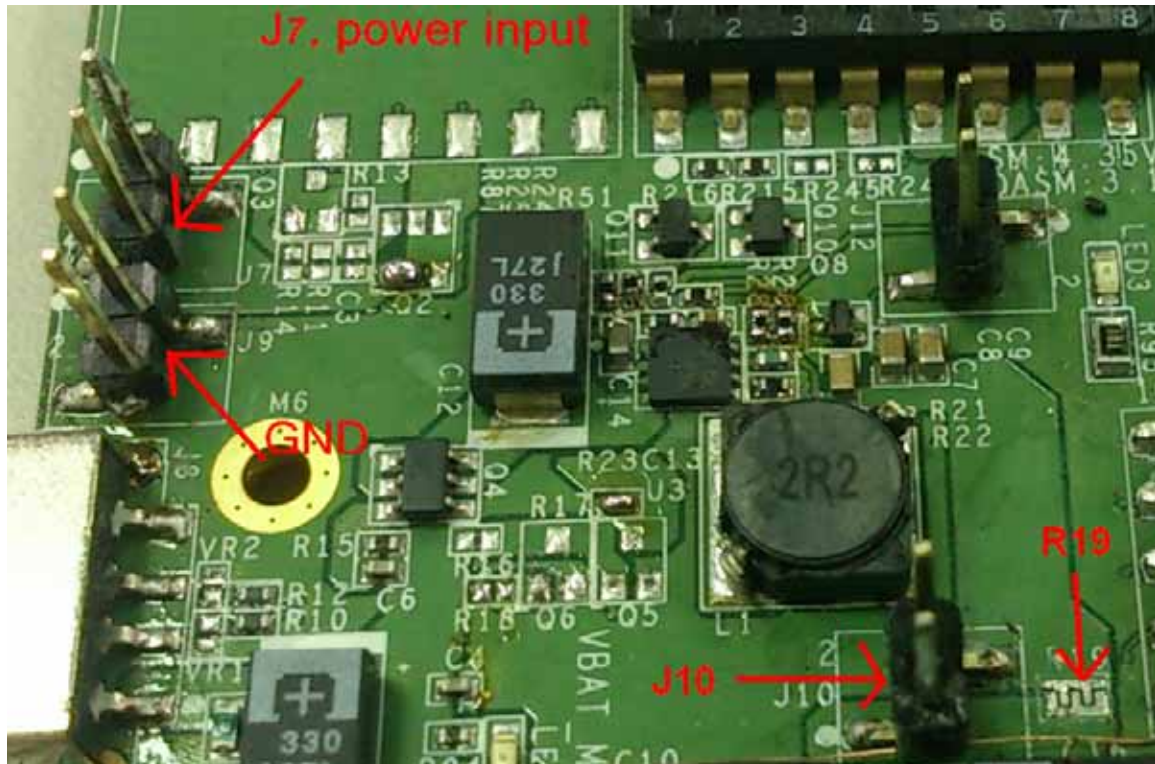

Figure. J7, J9, J10 & J19

8-4 Current Measurement

Step1. Clear solder on R20.

Step2. Measure two sides of J11.

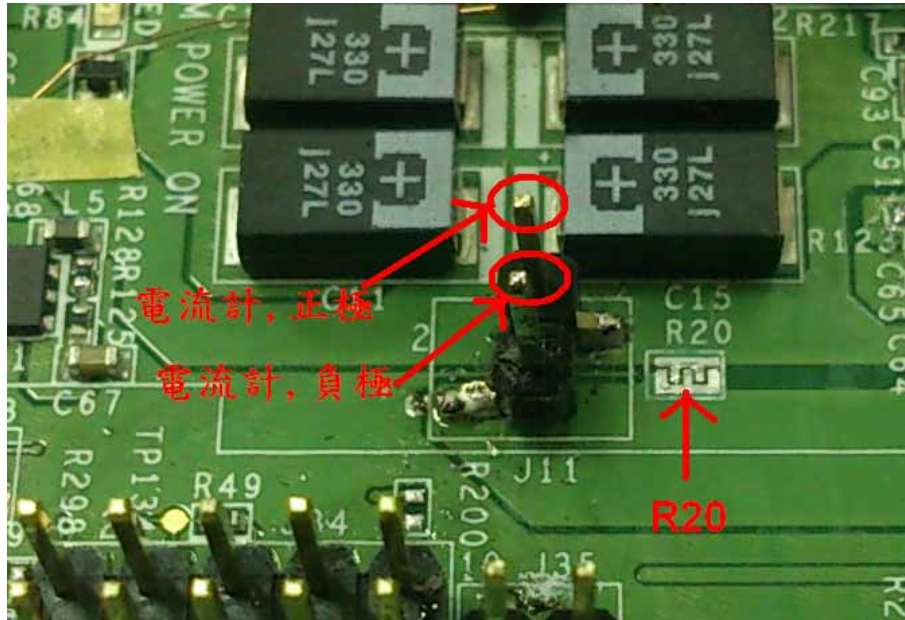

Figure. R20, J11

8-5 Settings for Slide-Style Switch (J42)

Component reference	Group	Function	OFF (Default)	ON
J42	1	Factory Test	V	
	2	Factory Test	V	
	3	Factory Test	V	
	4	Factory Test	V	
	5	Control UART0 (J18)	Open UART0 port	Close UART0 port
	6	Control UART1 (J19)	Open UART1 port	Close UART1 port
	7	PCM signal select	Import to internal Audio codec	Export to external connector. (J24)
	8	Factory Test	V	

In general mode, these eight switches should be set in 'OFF' position.

8-6 PCM Signal

8-6-1 PCM Signal Port (J24)

Step1. Group.7 switch in J42 should be in 'ON' position as follows.

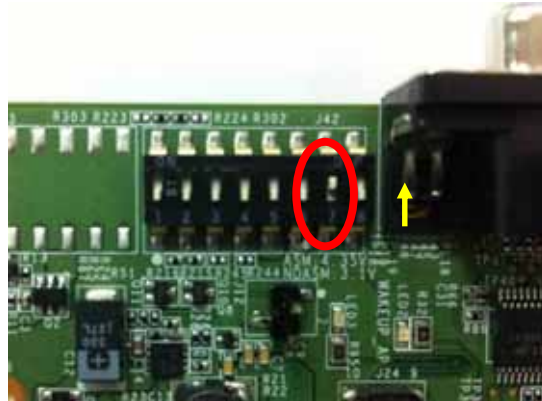

Step2. Please refer to the following photo to connect 'J24'.

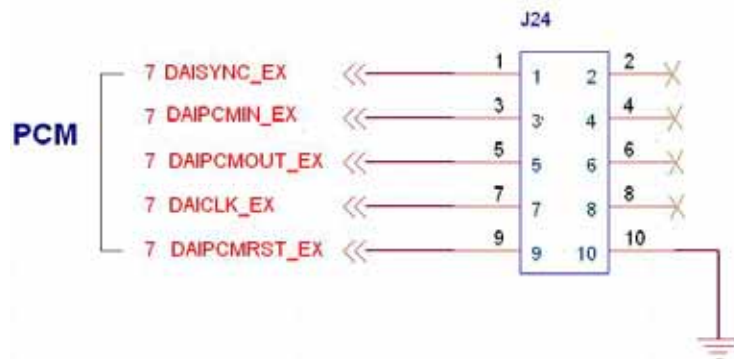
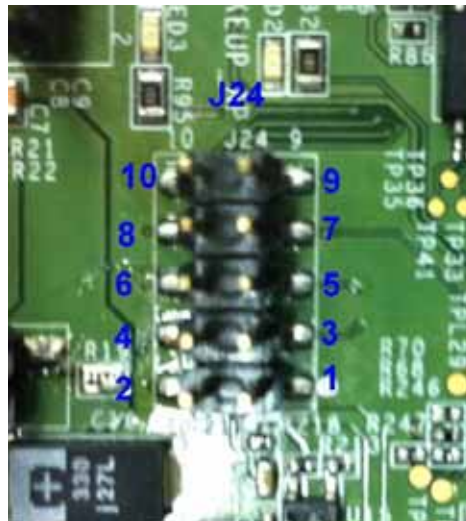

Step3. Then, please confirm signal level. **Default setting is 1.8V.** If you'd like 2.8V or 3.3V, please rework EVB by referring to following photos.

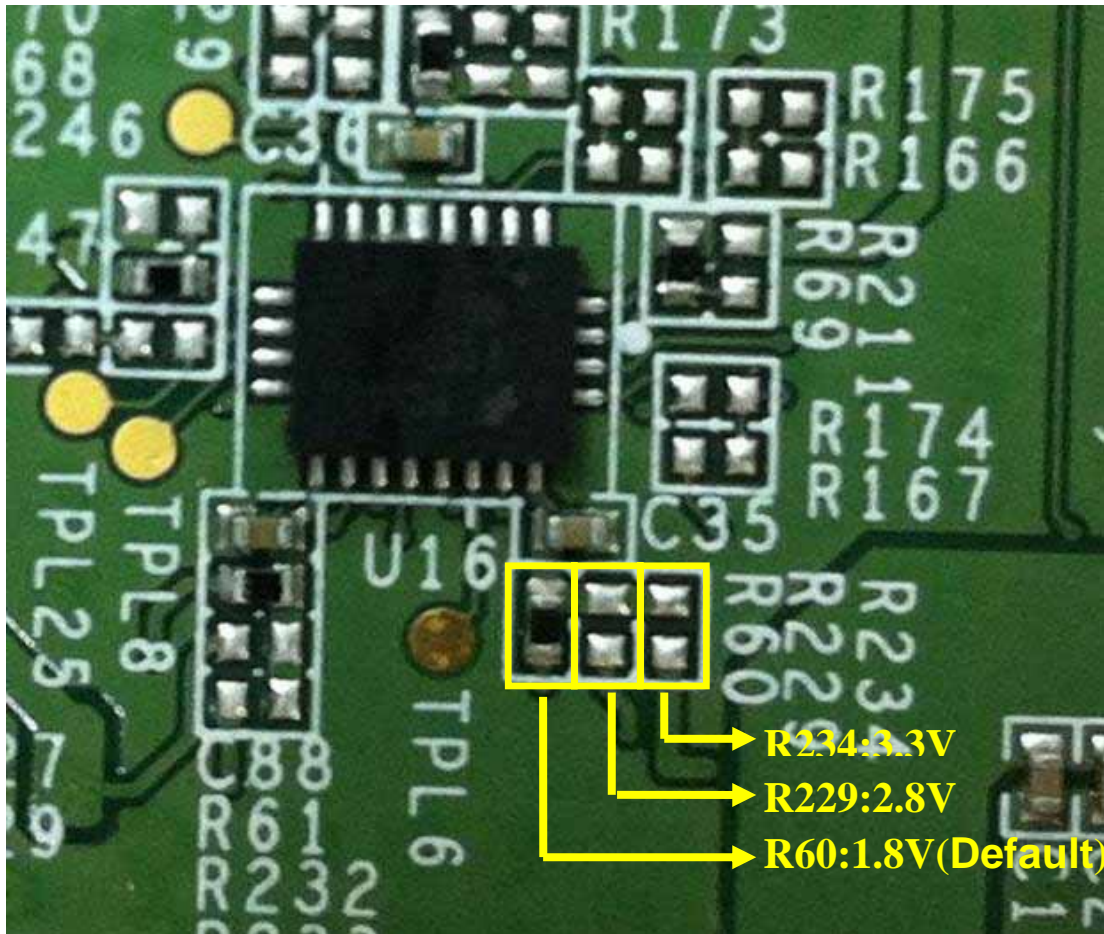

Figure. R20, J11

8-6-2 PCM Loop Settings

Step1. Please follow 8-6-1.

Step2. Put back the jumper in J24 to short its Pin.3 and Pin.5.



Figure. J24

8-6-3 External I²C Interface to Control Audio Codec

Step1. Group.7 switch in J42 should be in 'OFF' position as follows.

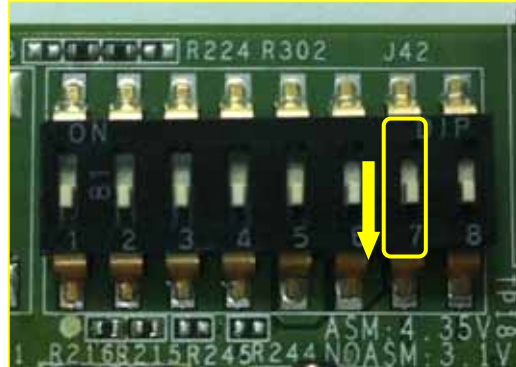

Figure. J42

Step2. AP could control modem by 'J25'. J25.8 is SCL. J25.10 is SDA. Voltage level is 1.8V.

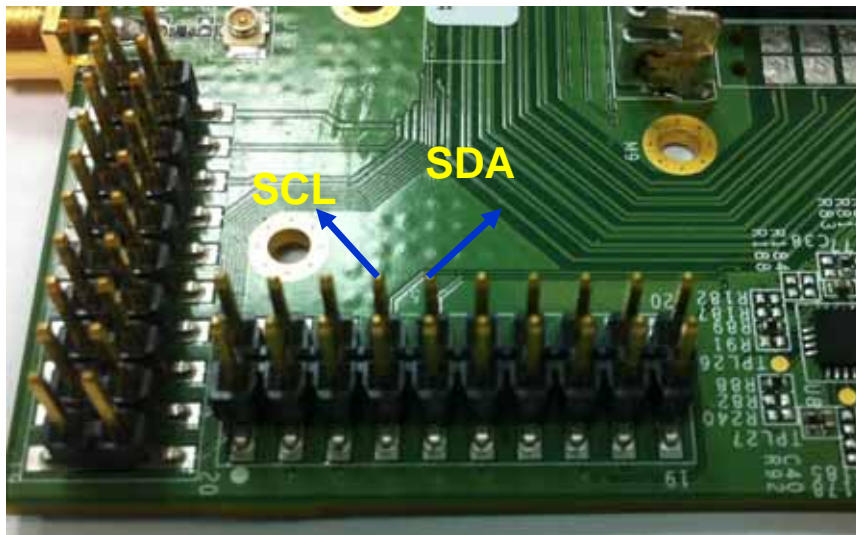

Figure. J25

Step3. About Codec init table, please refer to the file, 'UNA PLUS EVB Codec ReaTtek ALC5637Q Initial Table'.

8-7 UART0 & UART1 Signal Port (J23)

Step1. Group.5 (for UART0) & Group.6 (for UART1) switches in J42 should be in 'ON' position.

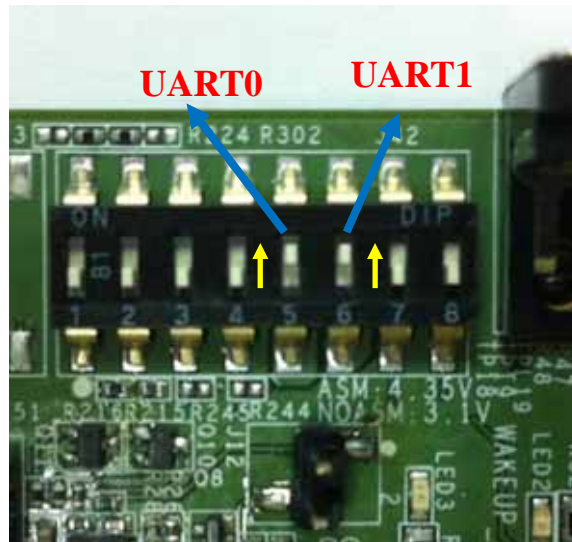

Figure. Group5&6 switches in J42

Step2. Please refer to the following photo to connect 'J23'.

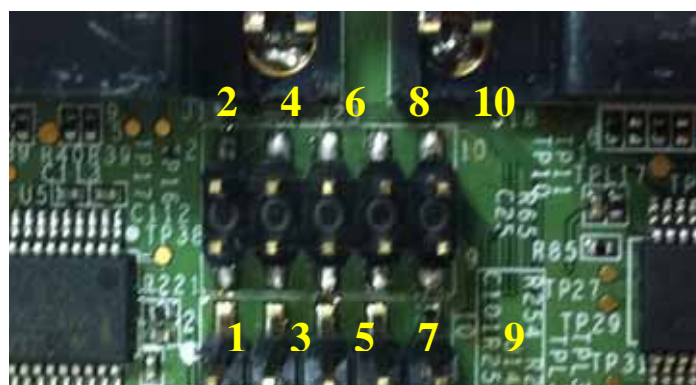
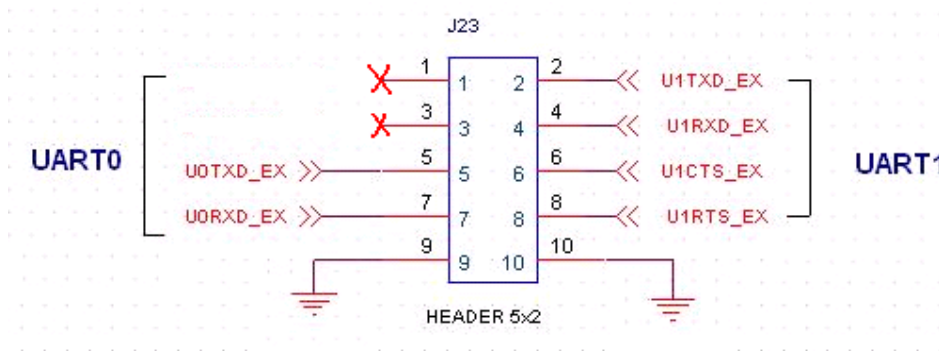

Figure. Pin definition of J23

Step3. Please confirm signal level. **Default setting is 3.3V**. If you'd like **1.8V** or **2.8V**, please refer to the following photo to rework the EVB. Please put back 'R241' (default setting) before you use UART0 (J18) and UART1 (J19).

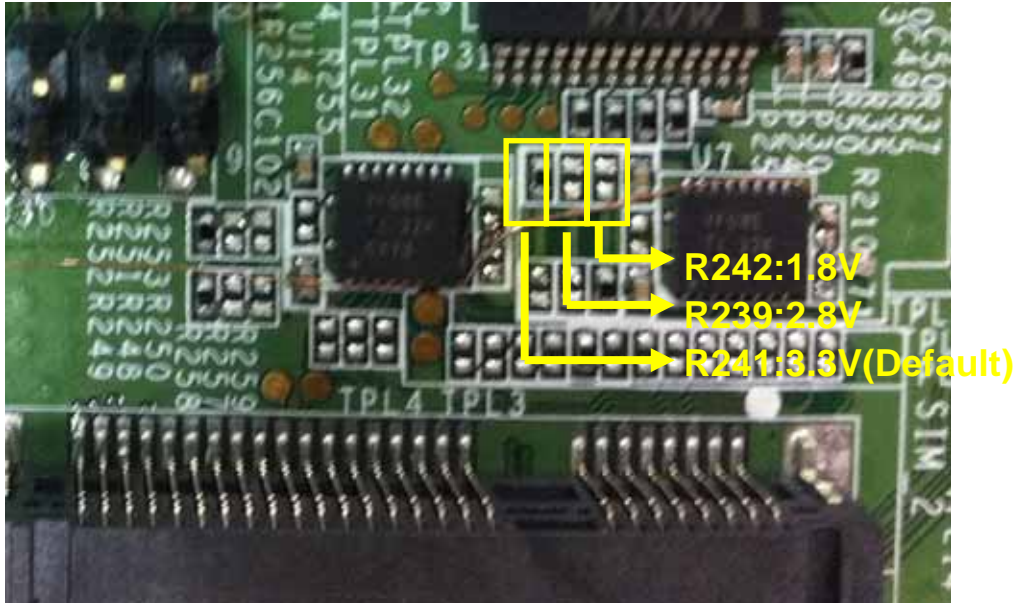

Figure. Voltage adjustment for UART.

8-8 Wakeup Control

8-8-1 USB Mode

Please comply with the following procedures, from step 1 to step 3.

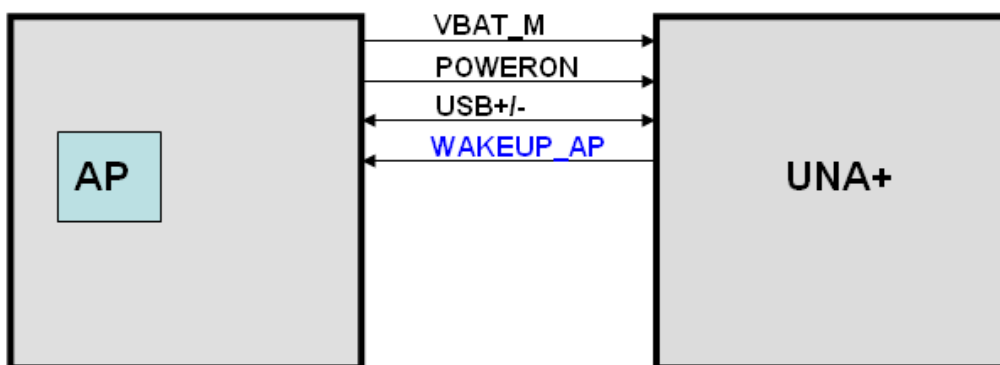

Figure. USB Mode

8-8-2 USB+UART Mode

Please comply with the following procedures, from step 1 to step 5.

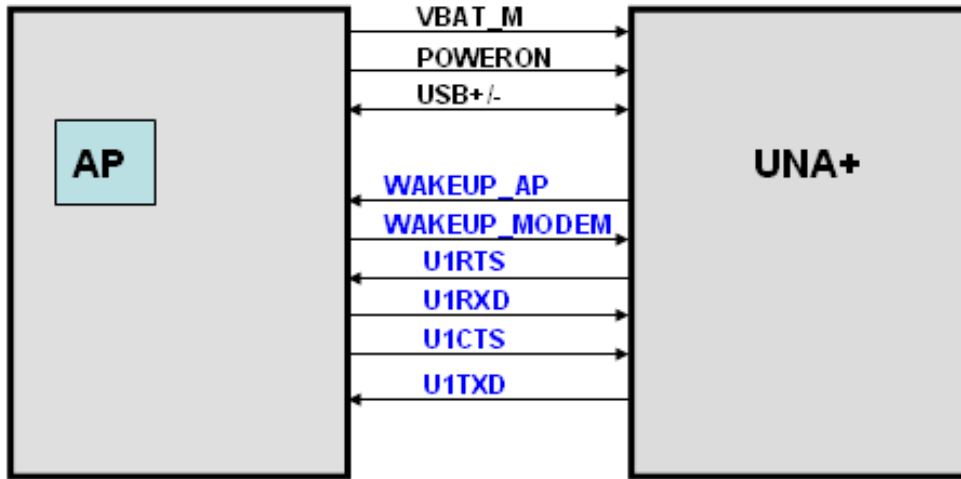

Figure. USB+UART Mode

Operation Procedure

Step1. Connect EVB & Host/AP by USB cable.



Figure. Connect Host/AP & EVB

Step2. Please refer to [Section 4-1, 'Module on/off control'](#), to start up modem.

Step3. Connect AP/Host and EVB by 'J56', Signal 'WAKEUP AP'. Voltage level is **1.8V**.

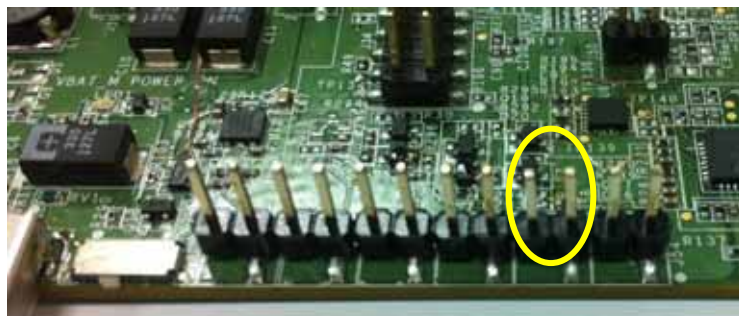

Figure. J56, Signal 'WAKEUP AP'

Step4. Connect AP/Host and EVB by **'J54.1'**, Signal **'WAKEUP MODEM'**.

Voltage level is **1.8V**. **'J54.1'** is marked in **yellow** circle in following picture.



Figure. J54.1, Signal **'WAKEUP MODEM'**

Step5. Please refer to **Section 4-7, 'UART0 & UART1 Signal Port (J23)'**, to connect UART port.

About timing diagram, please refer to the file **'UNA PLUS IO application design notes'**.

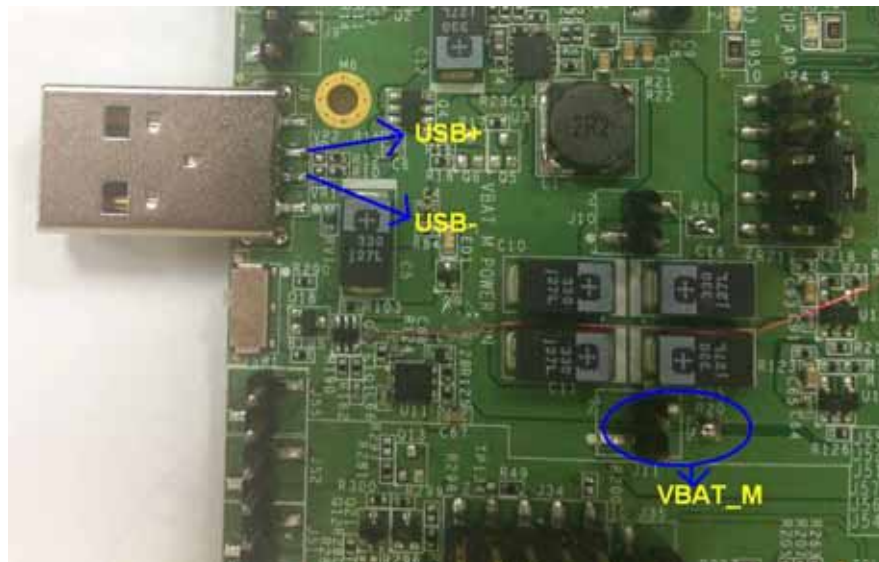

Figure. Positions of Pin **VABT_M**, **USB+** and **USB-**.

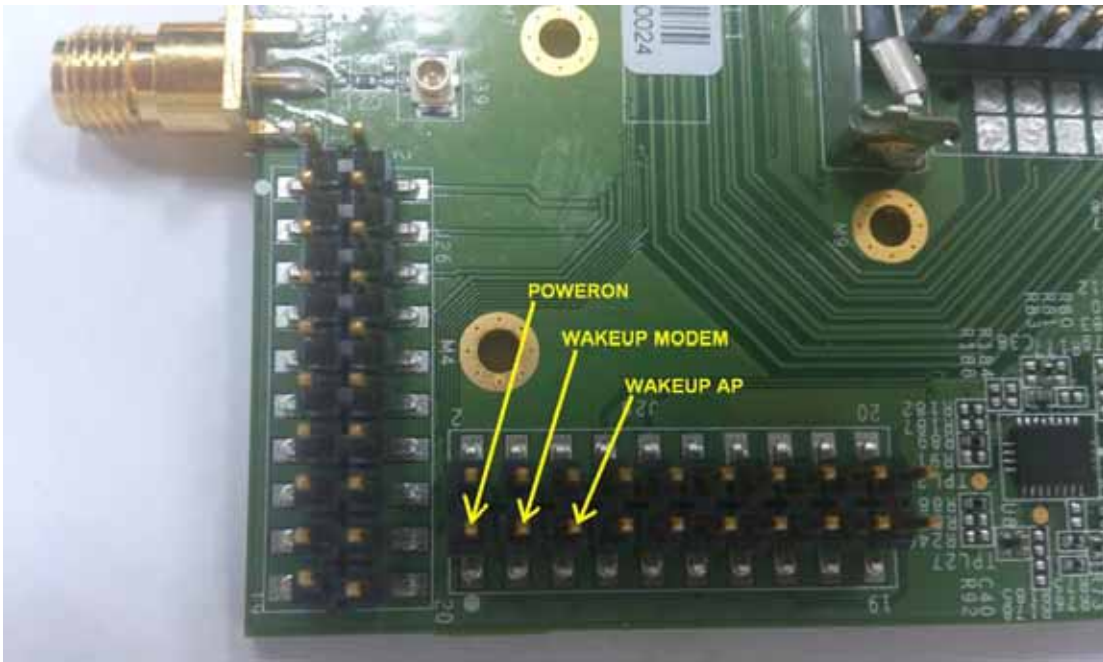

Figure. Positions of **POWERON** (J25.1), **WAKEUP AP** (J25.3) and **WAKEUP MODEM** (J25.5).