



PV1® VHF

Wireless microphone system



CONTENTS	2
INTRODUCTION	3
USING THIS MANUAL	3
SYSTEM FEATURES	3
PV®-1 RECEIVER	4
PV-1 HANDHELD MIRCROPHONE	
TRANSMITTER	7
PV-1 INSTR. BODYPACK TRANSMITTER	8
PV-1 LAVALIER/LAPEL OR HEADSET	
MICROPHONE BODYPACK TRANSMITTER	10
OPENING BATTERY COMPARTMENT	
HANDHELD	11
OPENING BATTERY COMPARTMENT	
BODYPACK	12
PV-1 INSTRUMENT BODYPACK	
TRANSMITTER	12
SPECIFICATIONS	12

INTRODUCTION

Thank you for purchasing a Peavy PV®-1 Diversity Wireless Microphone System. The PV-1 VHF wireless systems have user friendly features and are available in handheld, lavalier, headset, and guitar models.

USING THIS MANUAL

This booklet gives instructions for the operation of the PV-1 VHF wireless, including handheld, instrument, lavalier, headmic and plug-in transmitter systems. Please read the instructions for your system completely before operating unit. This manual will first list the features of the PV-1 and then will take you step by step on how to operate your system. After reading the receiver instructions, turn to the section of the booklet that covers the type of transmitter used with your new system. Each section will give you detailed operating instructions. Also included in this manual are system specifications and servicing information.

SYSTEM FEATURES

- Available on selected frequencies in the VHF high band (174-216 MHz) for long-range performance
- Proprietary compander circuitry for an industry-best 120dB Dynamic Range, and the clearest, most natural sound available
- Operating Range: Up to 250 feet typical (depending on site conditions)- 500+ feet line-of site
- Noise-free transmitter ON-OFF operation

PV-1 RECEIVER

- Half-rack receiver design with retractable front panel dual antennas
- Proprietary diversity digital processing circuitry to eliminate dropouts and maximize operating range
- RF and AF 4-LED displays for monitoring incoming signal strength and audio level
- Balanced XLR and unbalanced adjustable ¼" jack outputs
- Mute (squell) adjust control
- Externally powered by AC/DC power adapter
- Unique snap-out panel locking tabs for single receiver or dual receiver side-by-side. optional rack mounting kits available

PV®-1 HANDHELD MIC TRANSMITTER

- Features the Peavey unidirectional neodymium dynamic cartridge for optimum true sound, maximum feedback rejection and minimal handling noise
- OFF/ON/STANDBY switch allows convenient audio muting with the transmitter “ON”
- Low battery LED indicator flashes once for unit “ON”; lights steady for low battery alert
- Rubber, “easy mount” mic clip included

PV-1 BODYPACK TRANSMITTERS

- Choice of instrument (PV-1) or headset/lavalier microphone bodypack transmitter
- OFF/STANDBY/ON switch allows convenient audio muting with the transmitter “ON”
- Low battery LED indicator flashes once for unit “ON”; lights steady for low battery alert
- Locking 3.5mm mini-jack provides secure connection for removable microphone or instrument cable
- Easily accessible input level control for optimum sound

PV-1 RECEIVER

1. Powering the Receiver

Plug the 12V AC/DC ADAPTER (15) provided into the DC INPUT JACK (11) on the back of the receiver. Then plug the power supply into an AC outlet. (Note: Any 12V DC source with 400mA capability can also be used.) Press the POWER SWITCH (8) to turn the receiver on. The POWER ON LED (7) will now light and the receiver is operational.

2. Antennas

The PV-1 receiver is supplied with TELESCOPIC ANTENNAS (16). These should be extended fully to obtain maximum range. Optimal antenna positions 45 degrees from the receiver (at 90 degrees from each other). For maximum range, it is always best to maintain a line of sight

(no obstructions) between the receiver antennas and the transmitter at all times whenever possible.

3. Squelch Adjustment

In normal operation, the Squelch CONTROL (2) should be set fully counterclockwise to the factory preset minimum RF level. However, in areas of high RF activity, the mute (or squelch, as it is sometimes called) may need to be adjusted to compensate for the adverse conditions in a particular location. If, with the transmitter off, the receiver's A and/or B DIVERSITY LED INDICATORS (3) and/or one or more LEDs of the 4 LED RF LEVEL DISPLAY (4) flicker or stay on, the squelch control should be turned clockwise until the LEDs extinguish. When the squelch is properly adjusted, the A and/or B LEDs or the RF LEVEL LED displays will only light when the system transmitter is turned on. Turning the squelch control too far clockwise will reduce the range, but yield a quieter mute (squelch) function. During operation especially at ranges greater than 75 feet, one or the other of the A or B LEDs may extinguish briefly. This is normal. The unit's diversity reception ensures that the received audio will not be interrupted. When both the A/B DIVERSITY LEDs and the 4 LED RF LEVEL display extinguish, the transmitter is out of range for that given location, and the user should move closer to the receiver to re-establish the radio link.

4. Connecting the Audio Output

The PV®-1 receiver provides both a fixed mic level BALANCED AUDIO OUTPUT XLR (14) and an adjustable line level UNBALANCED AUDIO OUTPUT ¼" JACK (13). The level from the UNBALANCED OUTPUT is controlled by the rear panel VOLUME CONTROL (6). (Note: As when making any connection, make sure the amplifier or mixing board volume is at the minimum level before plugging in the receiver to avoid possible sound system damage.

Instrument Connection (using the PV-1 instrument transmitter)

Insert an audio cord with a ¼" mono phone plug in the UNBALANCED OUTPUT JACK (13) on the rear panel of the receiver. Plug the other end of the cord into an amplifier, effects, or mixing board. Adjust the VOLUME CONTROL (6) on the PV-1 receiver clockwise until the volume

level is comfortable for your application. This setting is roughly equivalent to a direct instrument cord connection.

Microphone Connection (using the PV®-1 transmitter with either a headset or lavalier microphone or the PV-1 handheld microphone transmitter)

For microphone use, either the BALANCED MIC AUDIO OUTPUT XLR (14) or the ¼" line level UNBALANCED OUTPUT (13) can be used. The XLR output is set at a non-adjustable microphone level, similar to hardwired mic levels. Plug an XLR connector into the XLR output jack on the rear of the unit and plug the other end into your amplifier or mixing board. (Note: Make sure your mixing board is turned off and the volume is turned down when making connections.) For your convenience, the XLR output level is preset at the factory and is not adjustable with the receiver volume control. To use the ¼" UNBALANCED OUTPUT JACK (13), follow the instructions for the Instrument Connection (above), except start with the receiver volume at ½" MAX and adjust the volume control until the volume level is optima. If the volume control is set too high, you may overload your mixer or amp.

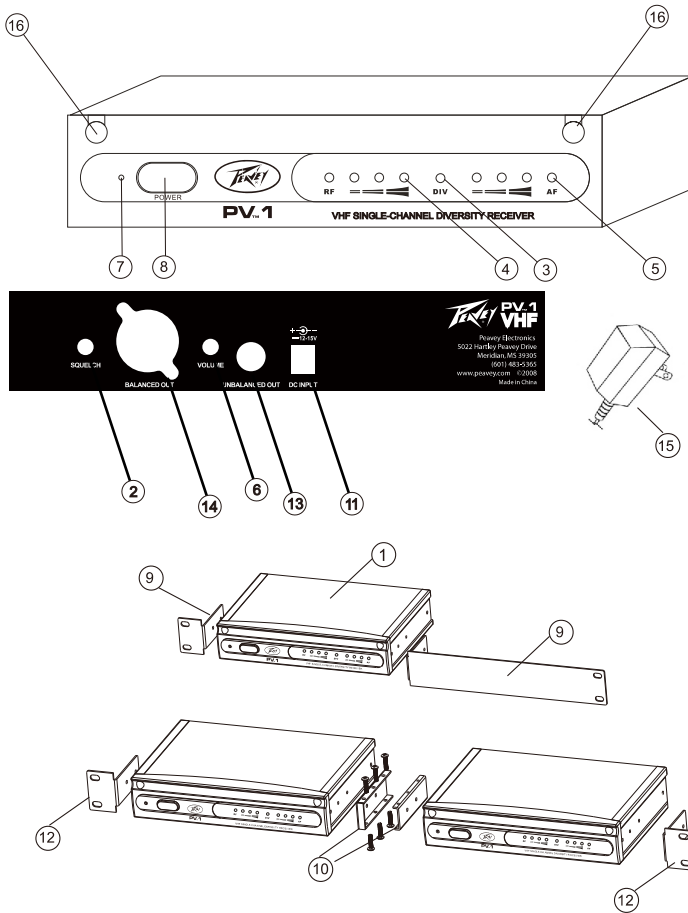

PV®-1 HANDHELD MICROPHONE TRANSMITTER

1. Unscrew the BATTERY COMPARTMENT COVER (17) and remove, exposing the BATTERY HOLDER (18). Insert a fresh 9V ALKALINE BATTERY (19), observing the correct polarity as marked, and screw the cover back on to the microphone. Make sure the cover is screwed on completely. A fresh alkaline battery can last up to 16 hours in use, but in order to ensure optimum performance, it is recommended that you replace the battery after every 10 hours of use.

2. Turn on the PV®-1 by sliding the OFF/ON/STANDBY SWITCH (20) to the STANDBY position (transmitter on, audio muted) or the ON position (transmitter and audio both on). The BATTERY INDICATOR LED (21) will give a single quick flash, indicating usable battery strength. In the case of a dead or low battery, the LED will either not flash at all or will stay on continuously, indicating that the battery should be replaced. To preserve battery life, turn the transmitter off when not in use.

3. The microphone is now ready to use. The A and/or B DIVERSITY LED INDICATORS (3) and most or all of the RF LEVEL DISPLAY LEDs (4) on the PV-1 receiver should now be illuminated, indicating a received signal from the transmitter. When ready to speak, slide the transmitter switch to the ON position. Adjust the volume of the receiver as per the Audio Output Microphone Connection section of the above PV-1 receiver instruction. The AF LEVEL LED DISPLAY (5) on the PV-1 receiver will light up to 5 LEDs (4 green and 1 red) for all input signals, Occasional flickering on and off during use of the top red LED indicator in this display is normal, however if the red LED stays on continuously, it means the signal is too loud and there is the possibility of overload distortion. Back off from the microphone until the red LED indicator only flickers on peaks.

[Note: Observe care in selecting P.A. volume, transmitter location and speaker placement so that acoustic feedback will be avoided.

[Note: Microphone elements can easily be destroyed by the buildup of salts and minerals from perspiration and saliva. It is good practice to put a windscreen on the mic element at all times to protect it.]

PV-1 INSTRUMENT BODYPACK TRANSMITTER

1. Snap open the BATTERY COMPARTMENT (3) and insert a fresh AA batteries (31), observing the correct polarity. Close the compartment. The PV-1 is provided with a 3.5 mm LOCKING JACK (32) for connecting the INSTRUMENT CABLE (35). To secure the connection, turn the metal slip ring on the plug clockwise to thread it on to the jack. To unplug, reverse the process. Slip the transmitter into a pocket or clip on to our clothes or instrument strap. (Note: As the cord to the instrument also serves as the antenna, be sure to extend it fully for maximum range. Rolling up or shortening the cord may reduce the effective operating range.

2. Turn on the PV@-1 by sliding the OFF/ON SWITCH (32) to the STANDBY position (transmitter on, audio muted) or the ON position (transmitter and audio both on). The BATTERY INDICATOR LED (33) will give a single quick flash, indicating usable battery strength. In the case of a dead or low battery, the Led either will not go on at all or will stay on continuously, indicating that the battery should be replaced.

3. The PV-1 transmitter is now ready to use. The A and/or B DIVERSITY LED INDICATORS (3) and most or all of the RF DISPLAY LEDs (4) on the PV-1 receiver should now be lit, indicating a received signal from the transmitter. Adjust the volume of the receiver as per the Audio Output Instrument Connections section of the above PV-1 receiver instructions. For optimum performance and INPUT LEVEL CONTROL (34) is provided on the top panel of the PV-1. Adjust the gain by turning the control with a small slot head screwdriver. It is recommended that this control be turned to maximum gain. However, for ultra high-gain instrument sources such as active bass pickups or even extra hot guitar pickups, turning the level down slightly will create a cleaner sound. (Note: Turning down the input gain too much can compromise the signal-to-noise ratio and is not recommended. Set for the maximum possible gain and headroom without noticeable distortion on the high level peaks). The AF LEVEL LED DISPLAY (5) on the PV-1 receiver will light up to 4 LEDs (3 green and 1 red) for all input signals. Occasional flickering on and off during use of the top red LED indicator in this display is normal, however if the red LED stays on continuously, turn down the instrument volume or adjust the INPUT LEVEL CONTROL (34) on the PV-1 transmitter, or noticeable distortion may result.

[Note: Scratchy noises can sometimes occur when some electric guitars/basses with dirty pots or connections are used with any wireless system. For this reason, the supplied INSTRUMENT CORD (35) has a factory installed capacitor inside the ¼" plug. This capacitor provides first order filtering of the RF signal from the cord into the guitar and eliminates virtually all scratchy noises. Should your equipment still give you scratchy noises, we suggest these steps to eliminate them:

- a. Make sure all guitar volume and tone pots are clean and all contacts are solid "C this is very important.
- b. Provide extra filtering with a 220 pF capacitor soldered across the hot to ground terminals of the guitar's volume and tone pots.

PV®-1 LAVALIER OR HEADSET MICROPHONE BODYPACK

1. Snap open the BATTERY COMPARTMENT (22) and insert a fresh AA batteries (23), observing the correct polarity. Close the compartment.
2. The PV-1 is provided with a 3.5 mm LOCKING JACK (24) for connecting the microphone, plug in either the LAVALIER/LAPEL (25) OR THE HEADSET MICROPHONE (26), as supplied. To secure the connection, turn the metal slip ring on the plug clockwise to thread it on to the jack. To unplug, reverse the process. Slip the transmitter into a pocket or clip on to your clothes. To use the lavalier mic, attach it a chest level. Do not place lavalier microphone too close to the mouth “C a distance of about six inches usually works best. To use the headset mic, place it on the head and adjust the mic boom so that the mic is about one inch to the side of the front of the mouth. (Note: The lavalier or headset mic wire is also the transmit antenna, and rolling up or shortening the wire may reduce the effective operating range. Extend the wire fully during use, and keep it as straight as possible.)
3. Turn on the PV-1 by sliding the OFF/STANDBY/ON SWITCH (27) to the STANDBY position (transmitter on, audio muted) or the ON position (transmitter and audio both on). The BATTERY INDICATOR LED (28) will give a single quick flash, indicating usable battery strength. In the case of a dead or low battery, the LED either will not go on at all or will stay on continuously, indicating that the battery should be replaced.
4. The microphone is now ready to use. The A and/or B DIVERSITY LED INDICTORS (3) and most or all of the RF DISPLAY LEDs (4) on the PV-1 receiver should now be illuminated, indicating a received signal from the transmitter. When ready to speak, slide the transmitter switch to the ON position and adjust the volume of the receiver as per the Audio Output Microphone Connection section of the above PV-1 receiver instructions. The AF LEVEL LED DISPLAY (5) on the PV-1 receiver will light up to 4 LEDs (3 green and 1 red) for all input signals. Occasional flickering on and off during use of the top red LED indicator in this display is normal, however if the red LED stays on continuously, it means the signal is too loud and there is the possibility of overload distortion. Re-position the microphone farther from the source or adjust the AUDIO INPUT LEVEL CONTROL (29) until the red LED indicator flickers only on the loudest inputs.

[Note: Observe care in selecting P.A. volume, transmitter location and speaker placement so that acoustic feedback will be avoided. Please also observe the pickup patterns of the microphone selected: omnidirectional mics pick up sound equally from all directions and are prone to feedback if not used carefully. Unidirectional mics are more resistant to feedback, but pick up sound sources best that are directly in front of the mic. Also, mics that are farther from the sound source, such as lavaliers, require more acoustic gain and thus are also more prone to feedback than close-source mics such as handheld or headset mics that are used close to the mouth.]

[Note: Microphone elements can easily be destroyed by the buildup of salts and mineral from perspiration and saliva. It is good practice to put a windscreen on the mic element at all times to protect it.

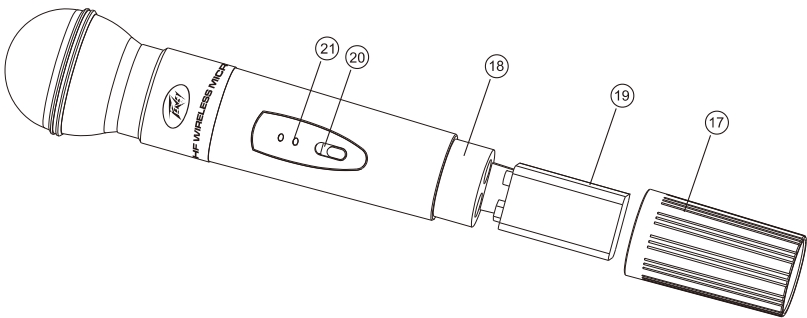

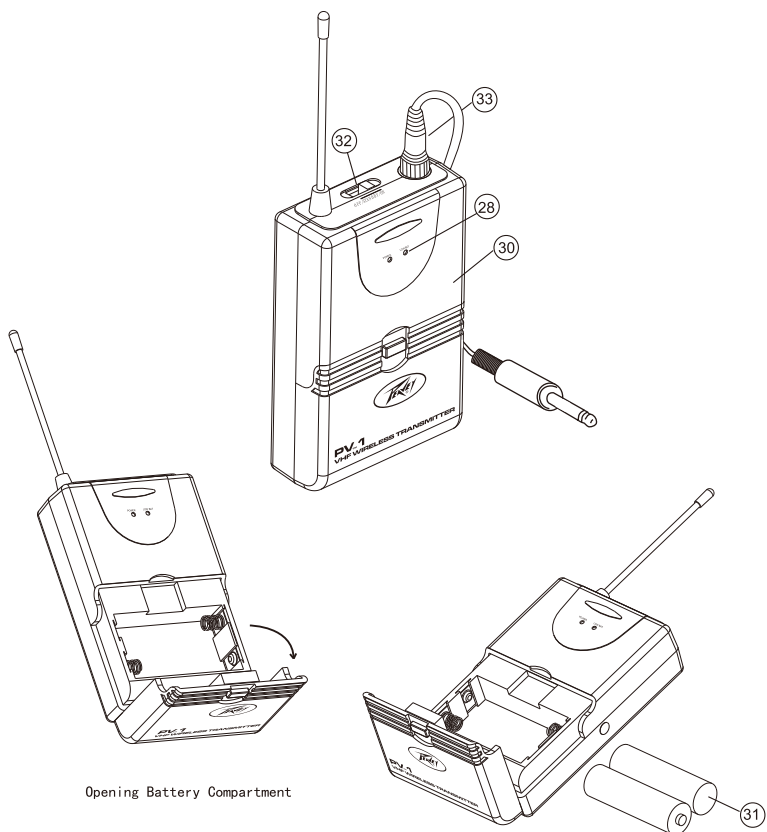

Opening Battery Compartment

SPECIFICATIONS

Frequency Response 40-20,000Hz, +/- 3dB
 Dynamic Range 120dB
 Total Harmonic Distortion <0.3%
 RF Carrier Frequency Range 174-216MHz.
 Frequency Stability +/- 0.005%, Crystal controlled
 Modulation FM (F3E), +/-20KHz max.

Note

This equipment has been tested and found to comply with the limits for a Class B digital device, pursuant to Part 15 of the FCC Rules. These limits are designed to provide reasonable protection against harmful interference in a residential installation. This equipment generates, uses and can radiate radio frequency energy and, if not installed and used in accordance with the instructions, may cause harmful interference to radio communications. However, there is no guarantee that interference will not occur in a particular installation. If this equipment does cause harmful interference to radio or television reception, which can be determined by turning the equipment off and on, the user is encouraged to try to correct the interference by one or more of the following measures:

- Reorient or relocate the receiving antenna
- Increase the separation between the equipment and receiver.
- Connect the equipment into an outlet on a circuit different from that to which the receiver is connected.
- Consult the dealer or an experienced radio/TV technician for help.

This device complies with Part 15 of the FCC Rules. Operation is subject to the following two conditions: (1) this device may not cause harmful interference, and (2) this device must accept any interference received, including interference that may cause undesired operation.

The manufacturer is not responsible for any radio or TV interference caused by unauthorized modifications to this equipment. Such modifications could void the user's authority to operate the equipment.

The antenna used for this transmitter must be installed to provide a separation distance of at least 20 cm from all persons and must not be co-located or operated in conjunction with any other antenna or transmitter

Specifications and features subject to change without notice

Peavey Electronics Corporation • 5022 Hartley Peavey Drive • Meridian • MS •
39305
(601) 483-5365 • FAX (601) 486-1278 • www.peavey.com
©2010 EX000129

