

STX3 Users Manual

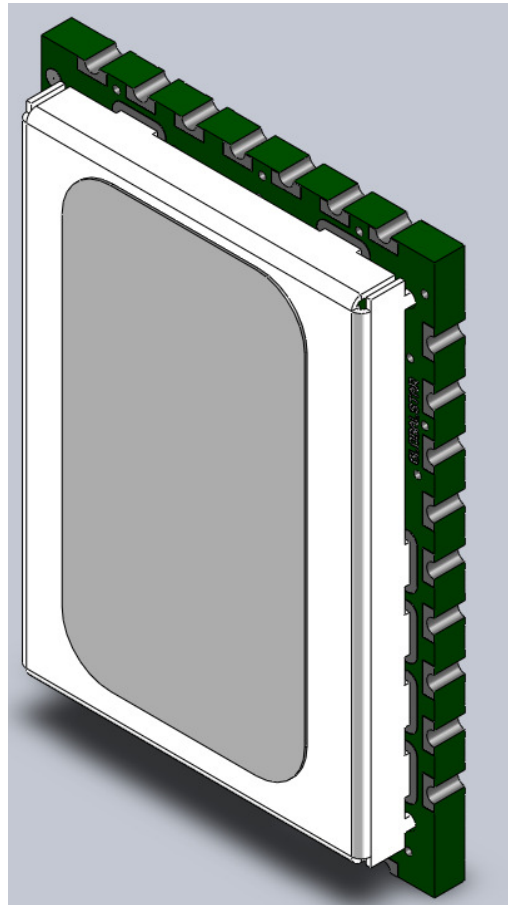

Table of Contents

1	Introduction	3
1.1	Purpose	4
1.2	Applicable Documents	4
1.3	Description	4
2	Application	5
2.1	Theory of Operation.....	5
2.2	Block Diagram	7
3	Physical Characteristics	9
4	Application Programming Interface.....	12
4.1	Serial Port.....	12
4.2	Serial Packet Mode	13
4.2.1	Serial Packet Format	13
4.2.2	Serial Packet Commands.....	14
4.2.2.1	Send Data (0x00).....	14
4.2.2.2	Query Electronic Serial Number (ESN) (0x01).....	14
4.2.2.3	Abort Transmission (0x03)	15
4.2.2.4	Query Bursts Remaining (0x04)	15
4.2.2.5	Query Firmware Version (0x05).....	15
4.2.2.6	Setup (0x06)	16
4.2.2.7	Query Setup (0x07)	16
4.2.2.8	Query Hardware Version (0x09)	17
4.3	Example CRC calculation routines for serial packets	19
4.4	AT commands.....	21
5	Test Modes.....	24
6	REGULATORY APPROVAL	26
6.1	Radio Astronomy Site Avoidance.....	26
6.2	Regulatory Notices.....	26

Revisions

1.0	11/05/2013	Initial Release
1.1	01/06/2014	Corrected VRF voltage range

1 Introduction

1.1 Purpose

This document describes the physical, electrical, and functional characteristics of the STX3 satellite transmitter module. The information contained in this document is intended to provide the end user with the necessary technical information required to use the module in a custom application.

This document is intended to be used by engineers and technical management and assumes a general knowledge of basic engineering practices by the user.

1.2 Applicable Documents

1.3 Description

The STX 3 is a simplex Satellite transmitter designed to send small packets of user defined data to a network of low earth orbiting (LEO) satellites using the Globalstar simplex satellite network. The received data is then forwarded to a user defined network interface that may be in the form of an FTP host or HTTP host where the user will interpret the data for further processing.

The STX3 is a surface mount module designed to attach to a user defined host PCB which must provide power, an RF connection to the transmit antenna, and communications with a host processor which will control the operation of the STX3. All electrical connections are provided via the castellated pads on the perimeter of the PCB.

The STX3 is a small, low-profile device with the dimensions shown below.

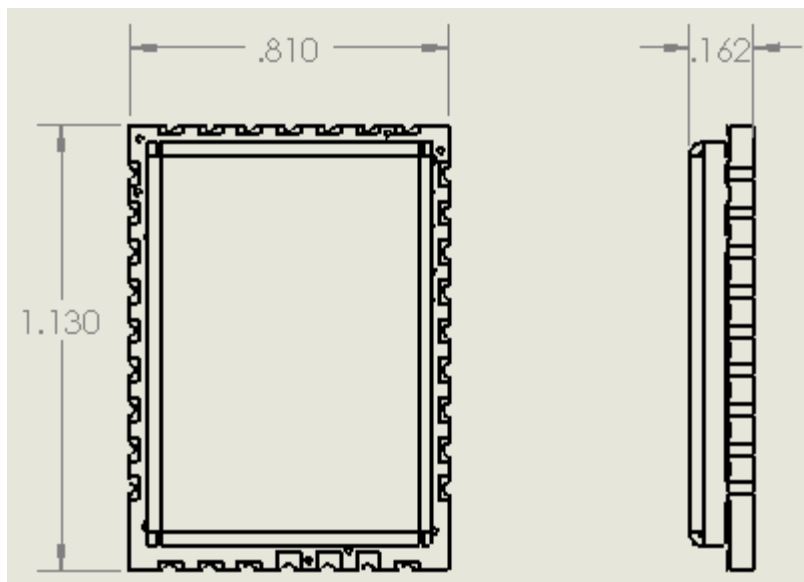

Figure 1 (dimensions in inches)

2 Application

2.1 Theory of Operation

The STX3 operates on the Globalstar LEO satellite network. LEO (Low Earth Orbit) means that there are a number of satellites in low earth orbit that constantly orbit the planet and can communicate with Globalstar devices that are within range of its current position.



Figure 2 LEO Constellation

Since the satellite position is constantly changing, simplex devices on the ground will transmit (with no knowledge of any of the satellites locations) and the transmission may be received by one or more satellites. These satellites will then relay the message to the nearest satellite gateway as shown below. Once received by the satellite gateway, the simplex message will be delivered to the simplex gateway where redundant messages are discarded and the data from the message is sent to the OEM via the Internet.

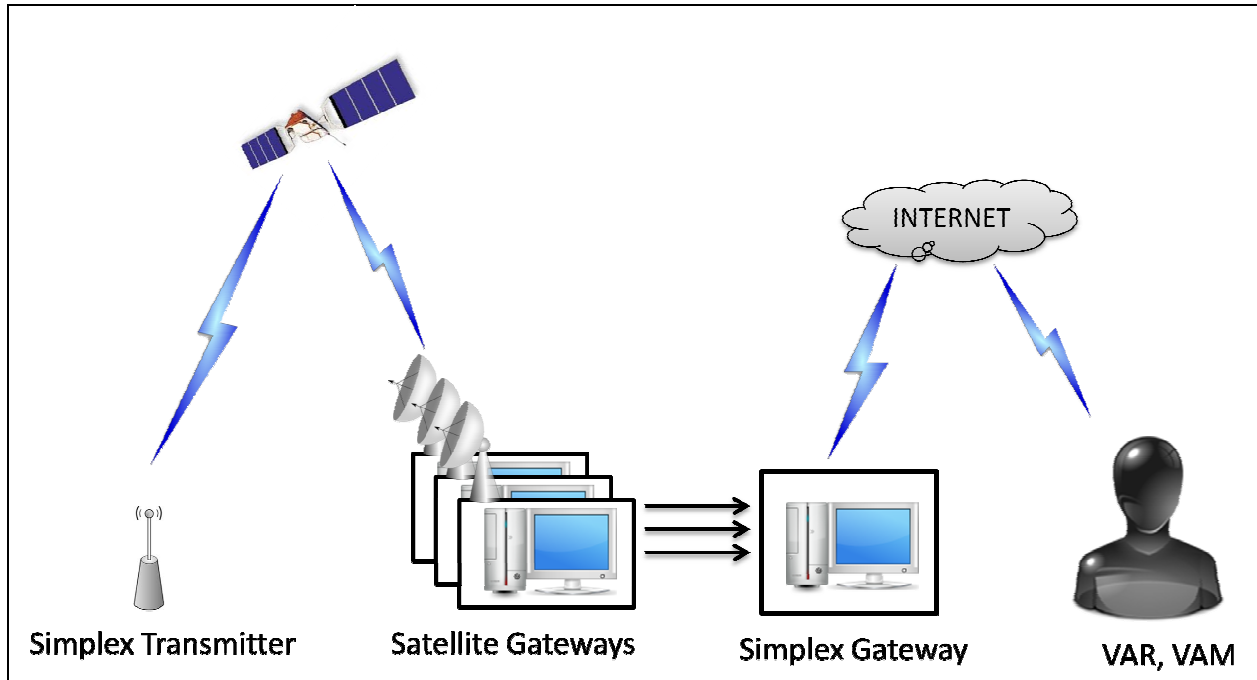
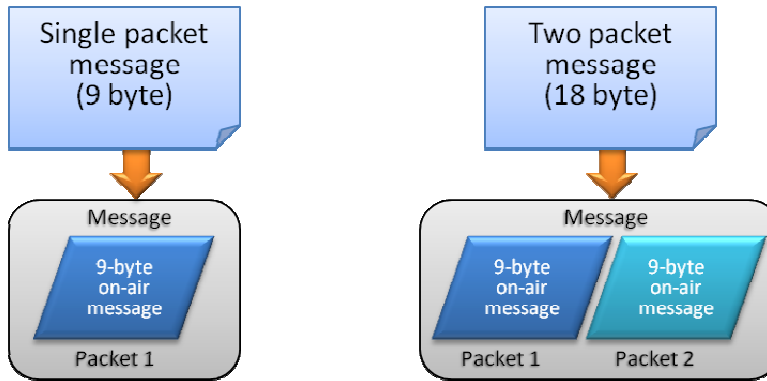

Figure 3 Simplex Messaging

Messages are composed of 1 or more 9-byte payloads. The STX3 can only transmit 9-byte on-air messages, so user payloads greater than 9 bytes will require multiple on-air packets to be transmitted for each user payload.



There are brief periods of time where there is no satellite in range of the simplex transmitters due to obstructions and/or satellite coverage geometry. Since a simplex device has no way of knowing if a transmitted message has been successfully received, the STX3 device is designed to send multiple (redundant) transmissions for each message being sent over the Globalstar network. The default value for the number of redundant transmissions per message is 3. This means that each message sent to the STX3 will be transmitted 3 times. Each transmission will contain the exact same data payload. The redundant transmissions of each message will be sent on a randomized 5-minute nominal interval.

The transmission sequence for a single-packet message using the default setting of 3 redundant transmissions is shown below.

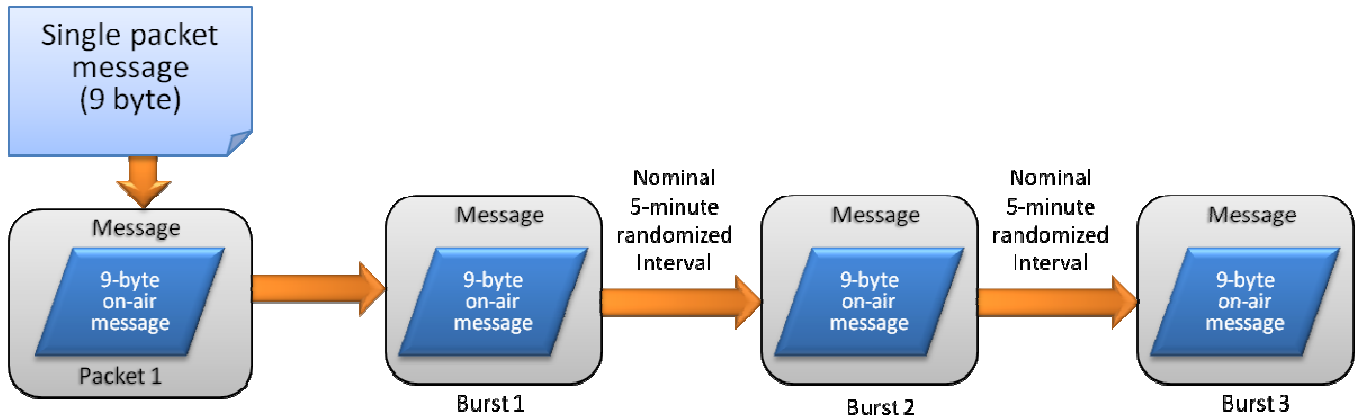

The transmission sequence for a two-packet message using the default setting of 3 redundant transmissions is shown below.

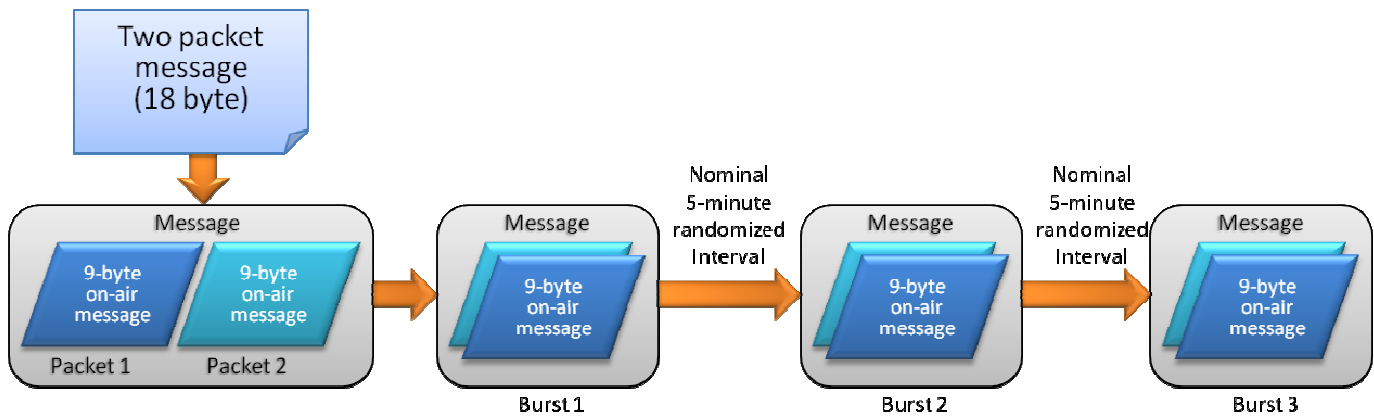

For normal conditions where the transmitter has an open view of the sky, this will result in a better than 99% chance that the message will be received.

2.2 Block Diagram

The basic elements of a design utilizing the STX3 simplex transmitter are shown below.

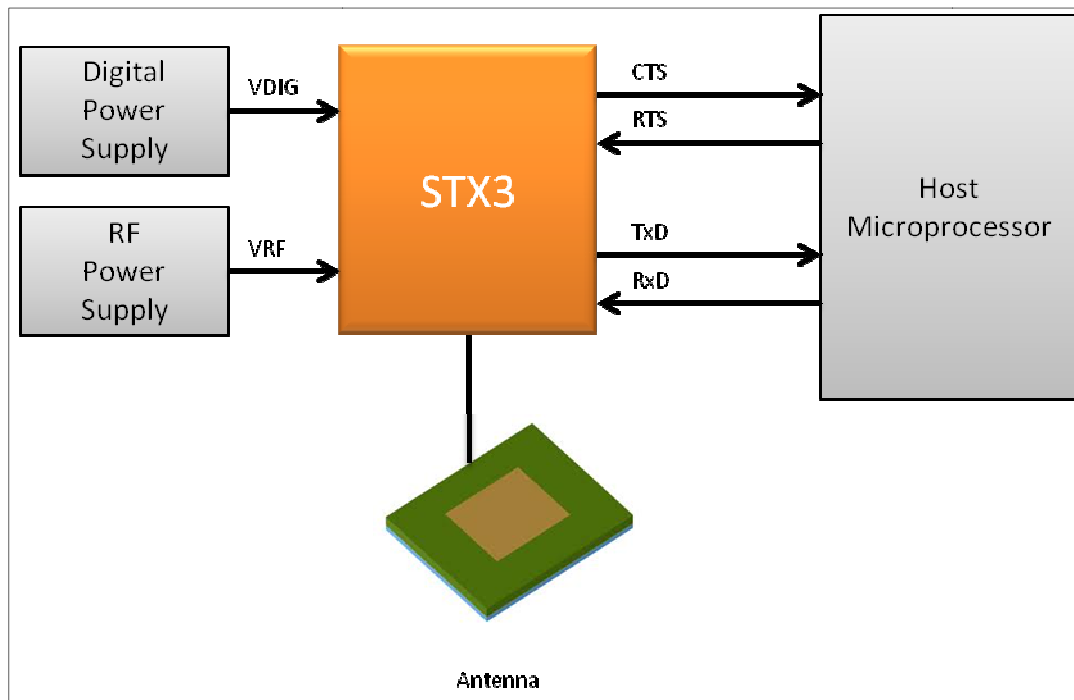

Figure 4

The STX3 provides separate power supply inputs. The digital power supply input (VDIG) is a low power input which powers the digital portion of the STX3. This provides the capability to leave the STX3 in a low power consumption state when the transmitter RF section is idle. The RF power supply input is a high power input which is only required while the STX3 is transmitting a data packet. Since the transmission duty cycle is very low, this supply may be turned off the majority of the time and only active during the transmission of a packet. Due to the random nature of the burst transmissions, an open collector output (PWR_EN) is provided by the STX3 which can directly control the high current supply for VRF. This will ensure that the RF power supply is enabled for the minimum amount of time to complete each transmission. It may also be monitored by the host to determine when each burst has been completed without the need to query the STX3 via the serial host interface.

3 Physical Characteristics

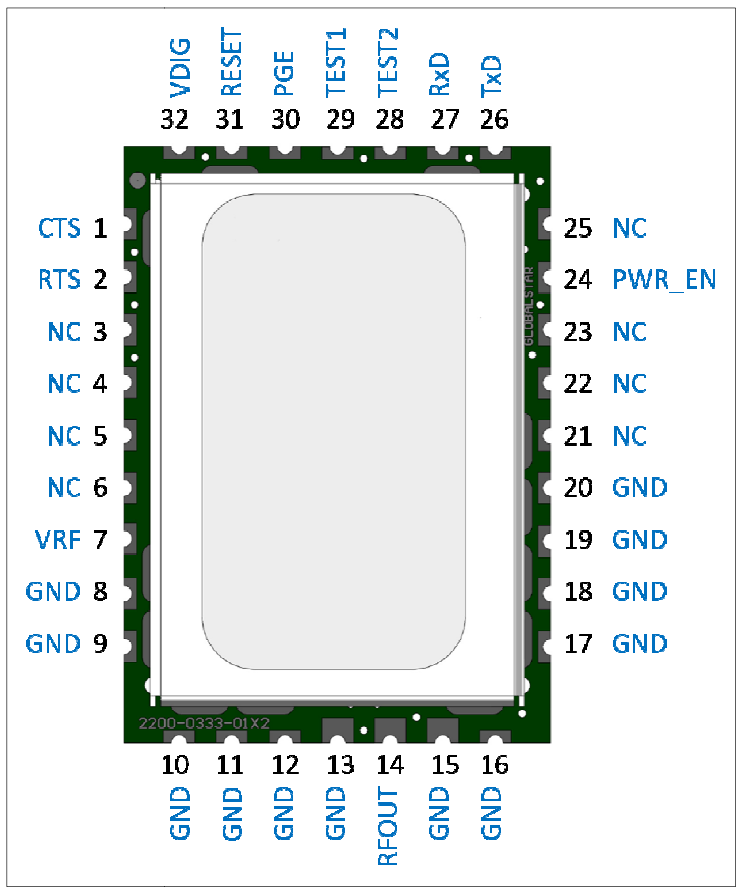

Figure 5 Top View

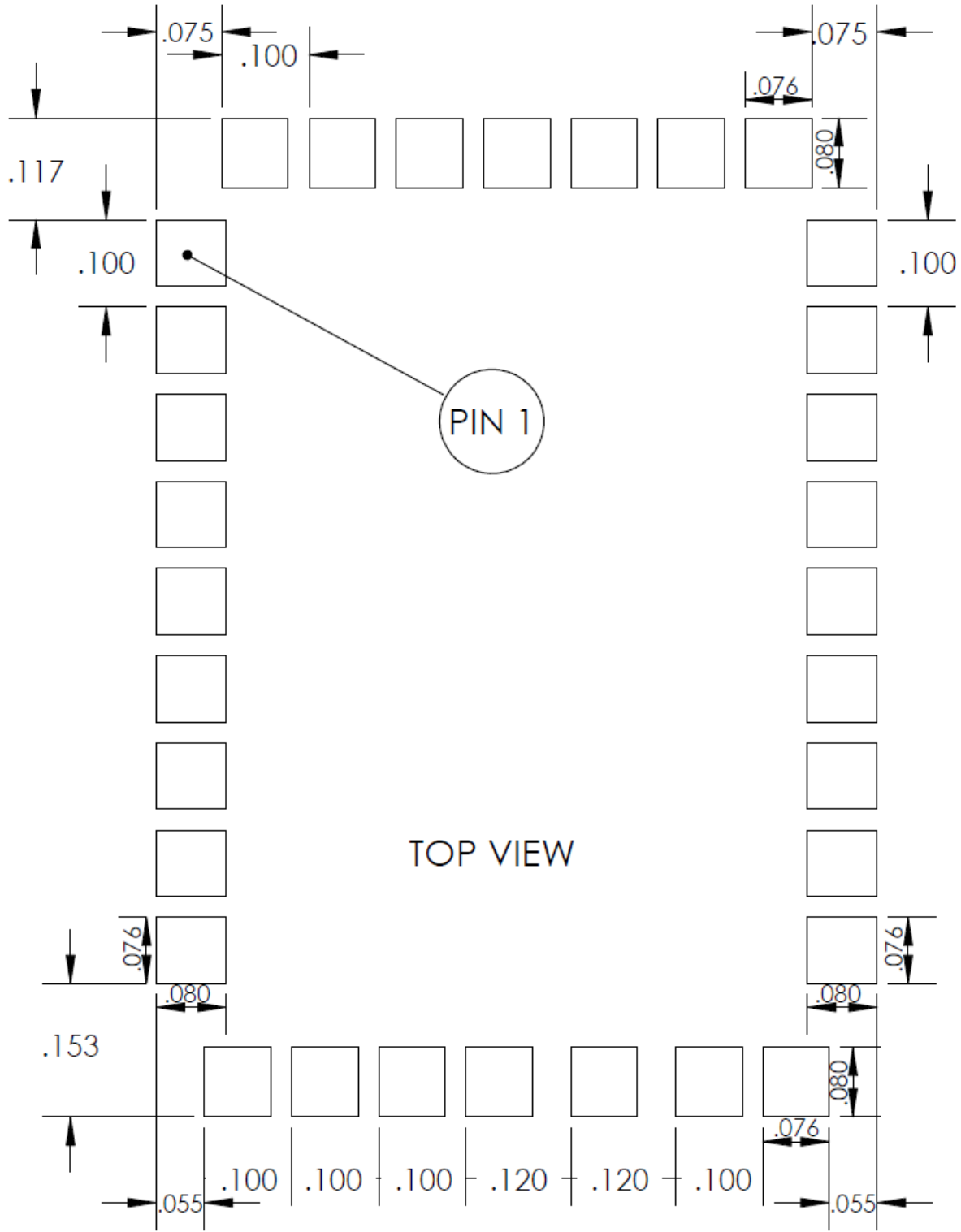

Figure 6 Recommended PCB footprint layout (dimensions in inches)

PIN	NAME	TYPE	Description
1	CTS	Output	5V tolerant, weak internal pull-up, may be pulled up to 5V max external
2	RTS	Input	5V tolerant, weak internal pull-up
3	RESERVED	No Connect	Do NOT connect
4	NC	No Connect	
5	NC	No Connect	
6	RESERVED	No Connect	Do NOT connect
7	VRF	Power In	3.0 to 3.6 Volts, 500 mA max load @ 3.3V
8	GND	Ground	
9	GND	Ground	
10	GND	Ground	
11	GND	Ground	
12	GND	Ground	
13	GND	Ground	
14	RFOUT	Output	50 ohm single ended antenna connection, use impedance matched trace
15	GND	Ground	
16	GND	Ground	
17	GND	Ground	
18	GND	Ground	
19	GND	Ground	
20	GND	Ground	
21	RESERVED	No Connect	
22	RESERVED	No Connect	
23	RESERVED	No Connect	
24	PWR_EN	Output	Open collector output to control VRF supply
25	NC	No Connect	
26	TxD	Output	5V tolerant, weak internal pull-up, may be pulled up to 5V max external
27	RxD	Input	5V tolerant, weak internal pull-up
28	Test2	Input	5V tolerant, weak internal pull-up
29	Test1	Input	5V tolerant, weak internal pull-up
30	RESERVED	No Connect	Do NOT connect
31	RESET	Input	Only drive with open collector, no external voltage to be applied
32	VDIG	Power In	3.0 to 5.0 Volts, 50 mA max load @ 3.3V

Operational Modes

Sleep Mode	Vcc is applied to the unit, no transmissions are pending, no serial activity
Active Mode	The STX3 is active and responding to the serial port but is not transmitting
Standby Mode	The STX3 is inactive between transmission bursts, but is not transmitting
Transmit Mode	The unit is transmitting an RF packet

Parameter	Test Conditions	Min	Typ	Max	Unit
TX output power	-40-85° C, Vcc=Vrf=3.3 volts, 50 ohm load	17.0	17.5	18.0	dB
Transmit mode supply current	-40-85° C, Vcc=Vrf=3.3 volts, 50 ohm load	315	325	350	mA
Active mode supply current	25° C, Vcc = 3.3 volts		2.3	2.5	mA
Standby mode supply current	25° C, Vcc = 3.3 volts		12	50	uA
Sleep mode supply current	25° C, Vcc = 3.3 volts		8	40	uA

4 Application Programming Interface

4.1 Serial Port

A half-duplex (0-3.0V) TTL asynchronous serial port (UART) is the primary interface to the user equipment. The serial port operates with the serial parameters of 9600bps, 8 data bits, no parity, 1 stop bit.

The RX data input and the RTS inputs are 5V tolerant. The TX data and CTS outputs are 0-3.0V TTL.

RS232 input levels are not supported. RS232 data must be converted to TTL before being sent to the unit.

Each command from the DTE to the modem (STX) is sent in a serial packet. Upon receiving the command, the modem answers to the DTE and, if applicable, executes the command.

In order to wake up the modem (STX) from sleep mode and to indicate the end of the serial packet, each serial packet must be framed by activating RTS before the first byte of the command and deactivating RTS after the last byte of the command.

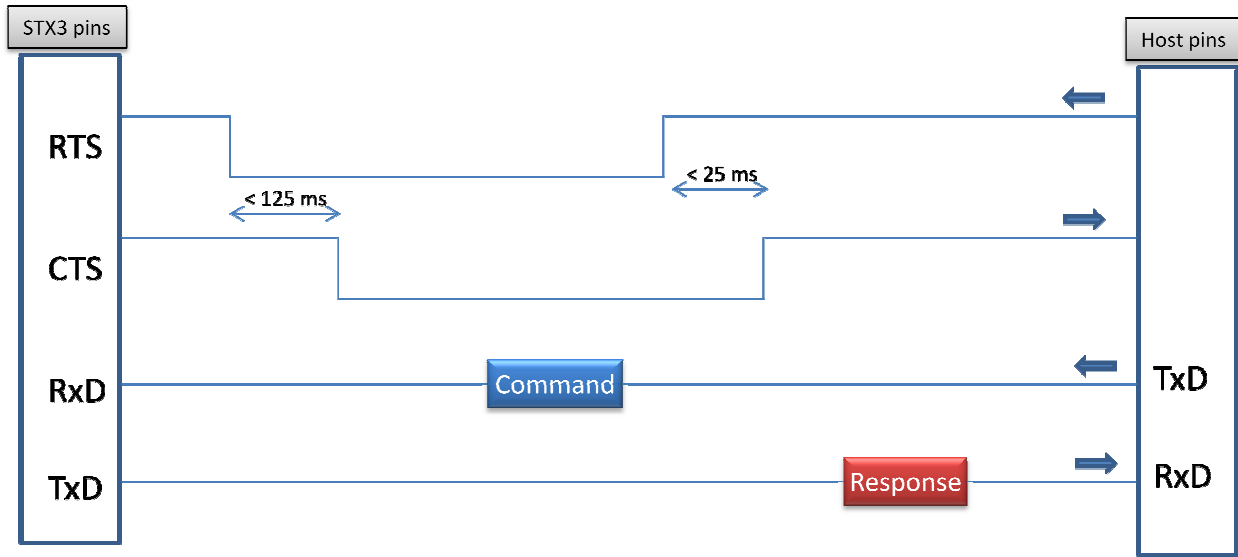

1. Lower RTS
2. Wait for CTS to go low
3. Send Command to STX3
4. Raise RTS
5. STX3 raises CTS
6. STX3 sends response

4.2 Serial Packet Mode

This mode is the legacy mode of operation as implemented in the STX2 which consists of binary data packets.

4.2.1 Serial Packet Format

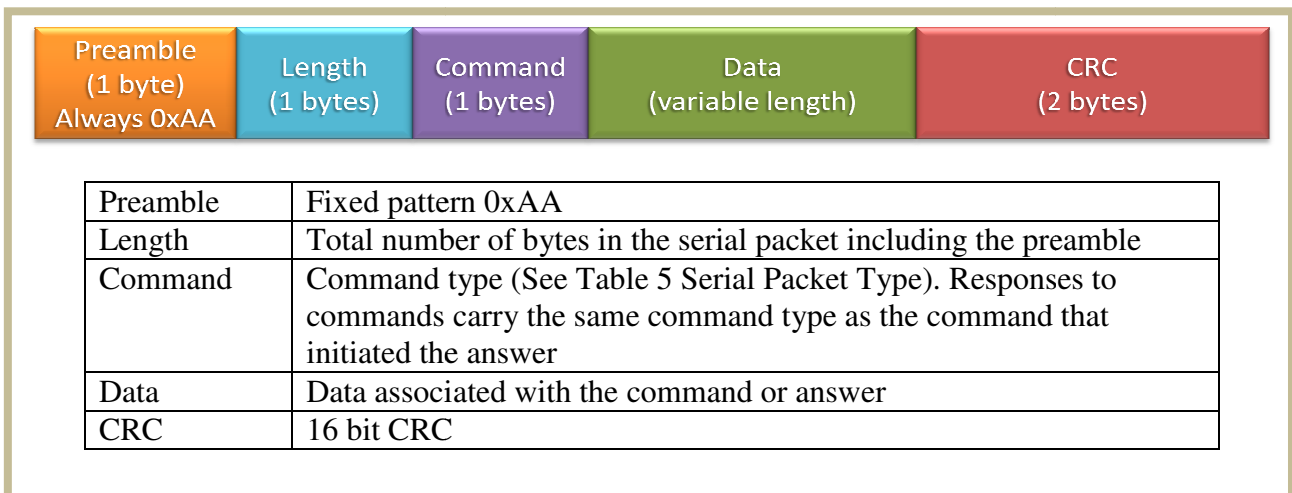

Figure 7 Serial Packet Format

4.2.2 Serial Packet Commands

For all serial packet commands as described below:

- AA is the **Preamble**.
- NN is the **Length**.
- **XX** is an unspecified byte value
- **CLSB** is the least significant **CRC** byte
- **CMSB** is the most significant **CRC** byte
- If an improperly formatted command is received, the STX3 will return a NAK response:

AA 05 FF A1 CB

4.2.2.1 Send Data (0x00)

The Send Data command requests the STX3 to send from 1 to 144 data bytes over the Globalstar Simplex network.

0x00

header	len	cmd	payload 1	payload 2	payload 3	..	payload N	CRC1	CRC2
AA	NN	00	XX	XX	XX	XX	XX	CLSB	CMSB

Example Command: AA 0E 00 01 02 03 04 05 06 07 08 09 BE E8

Response: AA 05 00 D9 C4

The example above commands the STX3 to send 9 bytes of **user defined data** over the Globalstar Simplex network. If the STX3 receives a properly formatted Send Data command, it returns an acknowledge response as shown above. If the command is not properly formatted, it will return the NAK response AA 05 FF A1 CB.

4.2.2.2 Query Electronic Serial Number (ESN) (0x01)

The Electronic Serial Number command requests the STX3 to respond with the units Electronic Serial Number (ESN).

0x01

header	len	Cmd	CRC1	CRC2
AA	05	01	50	D5

Command: AA 05 01 50 D5

Response:

header	len	Cmd	ESN				CRC1	CRC2
AA	09	01	XX	XX	XX	XX	86	7A

Example Response: AA 09 01 00 23 18 60 86 7A

Where the ESN returned is 2300000.

4.2.2.3 Abort Transmission (0x03)

The Abort Transmission command requests the STX3 to abort the current message transmit sequence over the Globalstar Simplex network.

0x03

header	len	Cmd	CRC1	CRC2
AA	05	03	42	F6

Command: AA 05 03 42 F6

Response: AA 05 03 42 F6

4.2.2.4 Query Bursts Remaining (0x04)

The Query Bursts Remaining command requests the STX3 to return the current number of bursts remaining the current message transmit sequence over the Globalstar Simplex network.

0x04

header	len	cmd	CRC1	CRC2
AA	05	04	FD	82

Command: AA 06 04 00 F4 33

Response:

Header	Len	04	count	CRC1	CRC2
AA	05	04	XX	CC	CC

Example Response: AA 06 04 00 F4 33

Where the bursts remaining returned is: 0

4.2.2.5 Query Firmware Version (0x05)

The Query Firmware Version command requests the STX3 to return the current firmware version.

0x05

header	Len	cmd	CRC1	CRC2
AA	05	05	74	93

Command: AA 05 05 74 93

Response:

header	Len	04	FW major	FW minor		CRC1	CRC2
AA	08	05	XX	XX	XX	CC	CC

Example Response: AA 08 05 **01 00 07** 57 44

Where the firmware version returned is: **1.07**

4.2.2.6 Setup (0x06)

The Setup command requests the STX3 to use the specified current setup parameters. These are stored in non-volatile memory.

0x06

Command:

header	len	04	RESERVED				RF channel	# of Bursts	Interval Min	Interval Max	RESERVED	CRC1	CRC2
AA	0E	06	XX	XX	XX	XX	XX	XX	XX	XX	XX	CC	CC

Where:

- RF channel : Valid values are: 0 = Channel A, 1 = Channel B, 2 = Channel C, 3 = Channel D
- # of bursts: Valid values are: 0x01 thru x14 (1 to 20 bursts)
- Minimum Burst Interval: Units of 5 seconds. Valid values are: 0x01 thru 0x3C (5 to 300 seconds)
- Maximum Burst Interval: Units of 5 seconds. Valid values are: 0x02 thru 0x78 (10 to 600 seconds)

Example Command: AA 0E 06 00 00 00 00 **00 03 18 30** 00 CE 9C

Where the setup information is:

- RF channel : 00 Channel A
- # of bursts: 03 3 bursts per message
- Minimum Burst Interval: 18 0x18 = 24, 24 x 5 = 120 seconds
- Maximum Burst Interval: 30 0x30 = 48, 48 x 5 = 240 seconds

4.2.2.7 Query Setup (0x07)

The Query Setup command requests the STX3 to return the current setup parameters.

0x07

header	len	cmd	CRC1	CRC2
AA	05	07	66	B0

Command: AA 05 07 66 B0

Response:

header	len	04	RESERVED	RF channel	# of Bursts	Interval Min	Interval Max	RESERVED	CRC1	CRC2
AA	0E	07	XX XX XX XX	XX	XX	XX	XX	XX	CC	CC

Where:

- RF channel : Valid values are: 0 = Channel A, 1 = Channel B, 2 = Channel C, 3 = Channel D
- # of bursts: Valid values are: 0x01 thru x14 (1 to 20 bursts)
- Minimum Burst Interval: Units of 5 seconds. Valid values are: 0x01 thru 0x3C (5 to 300 seconds)
- Maximum Burst Interval: Units of 5 seconds. Valid values are: 0x02 thru 0x78 (10 to 600 seconds)

Example Response: AA 0E 07 00 23 18 60 **00 03 18 30** 00 5D 60

Where the setup information returned is:

- RF channel : 00 Channel A
- # of bursts: 03 3 bursts per message
- Minimum Burst Interval: 18 0x18 = 24, 24 x 5 = 120 seconds
- Maximum Burst Interval: 30 0x30 = 48, 48 x 5 = 240 seconds

4.2.2.8 Query Hardware Version (0x09)

The Query Hardware Version command requests the STX3 to return the current hardware version information.

0x09

header	len	Cmd	CRC1	CRC2
AA	05	09	18	59

Command: AA 05 09 18 59

Response:

header	len	04	Device Code	Board Rev	CPU Rev	Radio Rev	CRC1	CRC2
AA	0A	09	00 01	XX	XX	XX	CC	CC

Where:

- Device Code : Always 1 for STX3
- Board Revision: STX3 hardware revision
- CPU Revision: STX3 CPU revision
- Radio Revision: STX3 radio revision

Example Response: AA 0A 09 00 01 **00 8E 62** E5 5E

Where the revision information returned is:

- Board Revision: 00
- CPU Revision: 8E
- Radio Revision: 62

4.3 Example CRC calculation routines for serial packets

The following example is written in the C programming language where:

int = 32 bits, short = 16 bits, char = 8 bits

```
unsigned short crc16_lsb(unsigned char *pData, int length)
{
    unsigned char i;
    unsigned short data, crc;

    crc = 0xFFFF;

    if (length == 0)
        return 0;

    do
    {
        data = (unsigned int)0x00FF & *pData++;
        crc = crc ^ data;

        for (i = 8; i > 0; i--)
        {
            if (crc & 0x0001)
                crc = (crc >> 1) ^ 0x8408;
            else
                crc >>= 1;
        }
    }while (--length);

    crc = ~crc;

    return (crc);
}
```

USAGE: **calculate the CRC for a message and update the message CRC**

```
unsigned short crc = crc16_lsb(msg, msg [1]-2);
```

```
msg [msg [1]-2] = (unsigned char) (crc&0xFF);
```

```
msg [msg [1]-1] = (unsigned char) (crc>>8);
```

The following example is written in the Java programming language:

```
char crc16_lsb(byte pData[], int length)
{
    int pData_i = 0;
    char s1,s2;

    byte i;
    char data, crc;

    crc = (char) 0xFFFF;
    if (length == 0)
        return 0;
    do
    {
        data = (char)((char)0x00FF & pData[pData_i++]);
        crc = (char)(crc ^ data);
        for (i = 8; i > 0; i--)
        {
            if ((crc & 0x0001) != 0)
                crc = (char)((crc >> 1) ^ 0x8408);
            else
                crc >>= 1;
        }
    }while (--length != 0);

    crc = (char)~crc;

    return (crc);
}
```

USAGE: **calculate the CRC for a message and update the message CRC**

```
byte msg[];     int len;
char crc = crc16_lsb(msg,len-2);
msg[len-2] = (byte)((short)crc & (short)0xff);
msg[len-1] = (byte)((short)crc >> 8);
```

4.4 AT commands

Command	Response	Comments
AT		This command is used to check communication between the module and the host.
	OK	STX3 is ready for normal operation
	ERROR	STX3 is not ready for operation, an error condition exists
AT+GSN? AT+CGSN?		Request product serial number identification
	+GSN: <n-nnnnnnn>	product serial number identification (ESN)
	ERROR	Unable to retrieve ESN
AT+GMM? AT+CGMM?	+GMM: STX3	Request model identification (hardware version).
AT+GMI? AT+CGMI?	+GMI: GLOBALSTAR	Request manufacturer identification
AT+GMR? AT+CGMR?		Request revision identification (firmware version).
	+GMR: <MM.mm>	MM=Major Revision, mm=Minor Revision Example: +GMR: 01.00
	ERROR	Unable to retrieve revision identification
AT+CMGS=<hhhh..hh>		Send message up to 144 data bytes specified by hexadecimal string Example: AT+CMGS=AA5511A53311A53311
	OK	Message Burst In Progress
	ERROR	Invalid message or modem error
AT+CMGSL=<Lat, NS, Lng, EW, hhhhhh>		Send location message with 3 data bytes specified by hexadecimal string. Lat: ddmm.mmmm

		<p>dd: decimal degrees, mm.mmmm minutes NS: hemisphere (N/S) Lng: dddmm.mmmm ddd: decimal degrees, mm.mmmm minutes EW: hemisphere (E/W) hhhhh: hexadecimal value of 3 byte payload Example: AT+CMGSL=3025.9857,N,09005.2182,W,A53311</p>
	OK	Message Burst In Progress
	ERROR	Invalid message or modem error
AT+CANX		Cancel running transmission.
	OK	Command OK (This command will never return an error. If no transmission is running, it will simply do nothing. This makes it possible for user code to just blindly send this command before any command to transmit if desired.)
AT+CGNTR?		Request the remaining number of total packet transmissions remaining in a running burst. The value returned by this query will represent the number of packets in the message times the number of burst transmissions remaining. For example, if two transmissions remain in the burst of a 4 packet message, a value of 8 will be returned. If no burst is in progress, a value of 0 will be returned. This command will never return an error.
	+CGNTR: <n>	n= Number of packets left in the burst Example: +CGNTR: 8
AT+CDFC=<channel number>		Set the default channel. Valid values are 0 – 3. Example: AT+CDFC=2
	OK	Command OK, channel was successfully set.
	ERROR	ERROR. Typically means channel number is out of range.
AT+CFDC?		Request current channel.
	+CFDC: <n>	N= current channel, a number between 0 and 3.
AT+CBNT=<Number of tries>		Set number of transmissions in burst. <Number of tries> = the number of transmissions in the burst. Range must be 1 – 16. Value may be sent in decimal or HEX format. HEX is indicated with a leading "0x".

	OK	Command OK, number of tries successfully set.
	ERROR	Unable to set number of tries. Most likely reason is that the number requested was out of range. Must be 1 – 16.
AT+CBNT?		Request number of tries setting for bursts.
	+CBNT: <n>	<n>= number of tries set for bursts.
AT+CBTMIN=<seconds>		Set the minimum time between transmissions in the burst in seconds. Acceptable range is 5 – 300 seconds. Value will be truncated by the device to the nearest divisible of 5. For example, if the number 207 is sent, the device will set the minimum to 205 seconds. Number may be sent in decimal or HEX format. HEX is indicated by a leading “0x”.
	OK	Command accepted and time set.
	ERROR	Time not set, most likely reason is the number was out of range.
AT+CBTMIN?		Query the minimum time between transmissions in the burst.
	+CBTMIN: <n>	Minimum time between transmissions in a burst, in seconds.
AT+CBTMAX=<seconds>		Set the maximum time between transmissions in the burst in seconds. Acceptable range is <CBTMIN> – 600 seconds. Value will be truncated by the device to the nearest divisible of 5. For example, if the number 532 is sent, the device will set the minimum to 530 seconds. Number may be sent in decimal or HEX format. HEX is indicated by a leading “0x”.
	OK	Command accepted and time set.
	ERROR	Time not set, most likely reason is the number was out of range.
AT+CBTMAX?		Query the maximum time between transmissions in the burst.
	+CBTMAX: <n>	Maximum time between transmissions in a burst, in seconds.
AT+BDREV?		Query the board revision of the STX3
	+BDREV: <n>	Board revision. TBD if this will even be implemented for the STX3, if unimplemented, will always return 0.
AT+PRREV?		Query the processor (CPU) revision of the Globalstar ASIC.
	+PRREV: <n>	Processor revision.
AT+RAREV?		Query the “radio” revision (revision of the transmitter side of the Globalstar ASIC).

	+RAREV: <n>	Transmitter revision.

5 Test Modes

The STX3 provides several test modes intended to aid in manufacturing testing and certification testing.

All test modes are activated by grounding selective pins on the STX3 prior to applying power. Once power is applied, the STX3 will sample the states of the pins and based on the states of the pins, the STX3 will enter the selected test mode. For normal operation these pins must be left floating or in a high (logic 1) state.

The following tables define the different test modes available in the STX3.

TEST1	TEST2	Mode
0	0	Mod Mode (continuous transmission) - A test packet is continuously transmitted. The test packet shall comply with the Air Interface Packet format with a user information equal to the hex stream 0x80AAAF0F0FAAF0F0F0 where the most significant bit is transmitted first
0	1	Test Packet - The test packet shall comply with the Air Interface Packet format with a user information equal to the hex stream 0x80AAAF0F0FAAF0F0F0 where the most significant bit is transmitted first
1	0	CW mode - An un-modulated carrier is continuously transmitted.
1	1	Normal Operation

The channels are selected via the Rx and RTS pins as follows

RX	RTS	Channel
0	0	B
0	1	C
1	0	D
1	1	Channel specified in the flash setup. To specify channel A, it must be the default channel specified in the flash setup. See Setup command for details.

6 REGULATORY APPROVAL

The STX3 module has received regulatory approvals for modular devices in the United States and Canada. Modular device approval allows the end user to place the STX3 module inside a finished product and not require regulatory testing for an intentional radiator (RF transmitter), provided no changes or modifications are made to the module circuitry. Changes or modifications could void the user's authority to operate the equipment. The end user must comply with all of the instructions provided by the Grantee, which indicate installation and/or operating conditions necessary for compliance. The integrator is still responsible for testing the end product for any additional compliance requirements required with this module installed (digital device emission, PC peripheral requirements, etc.) in the specific country that the end device will be marketed. For more information on regulatory compliance, refer to the specific country radio regulations in the following sections.

6.1 Radio Astronomy Site Avoidance

The end user device must comply with the requirements for Radio Astronomy Site avoidance as specified by the Globalstar National Science Foundation agreement of 2001. It must be compliant with CFR25.213.

6.2 Regulatory Notices

The STX3 has received Federal Communications Commission authorization under FCC Rules Part 25 as a modular transmitter. Final installation must be in compliance with 25.213 (see 6.1 above). The antenna installation and operating configurations of this transmitter must satisfy MPE categorical Exclusion Requirements of 2.1091. The antenna(s) used for this transmitter must be installed to provide a separation distance of at least 20 cm from all persons and must not be collocated or operating in conjunction with any other antenna or transmitter.

The STX3 module will satisfy FCC/IC modular transmitter requirements only when used with the antenna specified below. No power amplifiers may be used under the terms of this modular approval. No trace antennas are approved for use under the terms of this modular approval.

Manufacturer	Part Number	Polarization	Center Frequency (MHz)	Peak Gain (dB)
Spectrum	PA25-1615-025SA	LHCP	1615.25	3.0

The STX3 module has been labeled with its own FCC ID number, and if the FCC ID is not visible when the module is installed inside another device, then the outside of the finished product into which the module is installed must also display a label referring to the enclosed module:

<p>Contains Transmitter Module FCC ID: L2V-STX3 This device complies with Part 15 of the FCC Rules. Operation is subject to the following two conditions: (1) this device may not cause harmful interference, and (2) this device must accept any interference received, including interference that may cause undesired operation.</p>
--

The user's manual should include the following statements:

This equipment has been tested and found to comply with the limits for a Class B digital device, pursuant to part 15 of the FCC Rules. These limits are designed to provide reasonable protection against harmful interference in a residential installation. This equipment generates, uses and can radiate radio frequency energy, and if not installed and used in accordance with the instructions, may cause harmful interference to radio communications. However, there is no guarantee that interference will not occur in a particular installation. If this equipment does cause harmful interference to radio or television reception, which can be determined by turning the equipment OFF and ON, the user is encouraged to try to correct the interference by one or more of the following measures:

- Reorient or relocate the receiving antenna.
- Increase the separation between the equipment and receiver.
- Connect the equipment into an outlet on a circuit different from that to which the receiver is connected.
- Consult the dealer or an experienced radio/TV technician for help.

WARNING: Changes or modifications not expressly approved by Globalstar may render the device non-compliant to FCC and other regulatory body standards for operation and may void the user's authority to operate the equipment.

This device complies with Part 15 of the FCC Rules. Operation is subject to the following two conditions: (1) This device may not cause harmful interference, and (2) this device must accept any interference received, including interference that may cause undesired operation.

This ClassA/ClassB digital apparatus complies with Canadian ICES-003.

This device will operate in accordance to the standards set forth by the CE Mark Directives and standards R&TTE: (TBR41 v1.1.1 May 2000, EN 301 441), RFI: (EN61000-4-3:1996 + A1:1998 + A2:2000), ESD: (EN61000-4-2: 1995 + A1:1998)

NOTICE: This equipment complies with the FCC RF Exposure Limits. A minimum of 20 centimeters (8 inches) separation between the device and the user and all other persons should be maintained.

FCC ID: L2V-STX3
ICES-003/(A/B)
IC:3989A-STX3



R&TTE: TBR41



Complies with FCC standards.
FOR HOME OR OFFICE USE