

Rhein Tech Laboratories
360 Herndon Parkway
Suite 1400
Herndon, VA 20170
<http://www.rheintech.com>

Client: Ohmart/VEGA
Model: VEGAPULS 68
FCC ID: MOIPULS68
Standards: FCC 15.209/IC RSS-210
Report Number: 2004236

APPENDIX E: MANUAL

Please see the following pages.

VEGA

Operating Instructions

VEGAPULS 68

4 ... 20 mA/HART

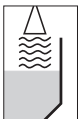

Contents

1 About this document

1.1 Function	4
1.2 Target group	4
1.3 Symbolism used.	4

2 For your safety

2.1 Authorised personnel	6
2.2 Appropriate use	6
2.3 Warning about misuse	6
2.4 General safety instructions	6
2.5 CE conformity	7
2.6 Compatibility acc. to NAMUR NE 53	7
2.7 FCC conformity (only for USA/Canada)	8
2.8 Safety information for Ex areas	8
2.9 Environmental instructions.	8

3 Product description

3.1 Configuration	9
3.2 Principle of operation	10
3.3 Adjustment.	11
3.4 Storage and transport.	11

4 Mounting

4.1 General instructions	13
4.2 Mounting preparations, horn antenna.	14
4.3 Mounting preparations, parabolic antenna	15
4.4 Mounting information	16

5 Connecting to power supply

5.1 Preparing the connection	22
5.2 Connection procedure	23
5.3 Wiring plans, single chamber housing	24
5.4 Wiring plans, double chamber housing	26
5.5 Wiring plans, double chamber housing Exd	28

6	Setup with the indicating and adjustment module PLICSCOM	
6.1	Short description	31
6.2	Installing the indicating and adjustment module PLICSCOM	31
6.3	Adjustment system	33
6.4	Setup procedure	34
6.5	Menu schematic.	39
7	Setup with PACTware™	
7.1	Connecting the PC	42
7.2	Parameter adjustment with PACTware™	43
8	Maintenance and fault rectification	
8.1	Maintenance	45
8.2	Fault rectification	45
8.3	Exchanging the oscillator	47
8.4	Instrument repair	49
9	Dismounting	
9.1	Dismounting procedure.	51
9.2	Disposal	51
10	Supplement	
10.1	Technical data	52
10.2	Dimensions	59
10.3	CE declaration of conformity	70

1 About this document

1.1 Function

This operating instructions manual has all the information you need for quick setup and safe operation of VEGAPULS 68. Please read this manual before you start setup.

1.2 Target group

This operating instructions manual is directed to trained personnel. The contents of this manual should be made available to these personnel and put into practice by them.

1.3 Symbolism used



Information, tip, note

This symbol indicates helpful additional information.



Caution, warning, danger

This symbol informs you of a dangerous situation that could occur. Ignoring this cautionary note can impair the person and/or the instrument.



Ex applications

This symbol indicates special instructions for Ex applications.



List

The dot set in front indicates a list with no implied sequence.



Action

This arrow indicates a single action.

1 **Sequence**

Numbers set in front indicate successive steps in a procedure.

2 For your safety

2.1 Authorised personnel

All operations described in this operating instructions manual must be carried out only by trained and specialist personnel authorised by the operator. For safety and warranty reasons, any internal work on the instruments must be carried out only by personnel authorised by the manufacturer.

2.2 Appropriate use

VEGAPULS 68 is a sensor for continuous level measurement.

2.3 Warning about misuse

Inappropriate or incorrect use of the instrument can give rise to application-specific hazards, e.g. vessel overflow or damage to system components through incorrect mounting or adjustment.

2.4 General safety instructions

VEGAPULS 68 is a high-tech instrument requiring the strict observance of standard regulations and guidelines. The emitting frequencies of all VEGAPULS sensors are in the C or K-band range (depending on the instrument version). The low emitted powers are far below the internationally permitted limit values, in case of correct use, no health problems are expected. There are no restrictions in using the instrument also outside metallic, closed vessels. The user must take note of the safety instructions in this operating instructions manual, the country-specific installation standards (e.g. the VDE regulations in Germany) as well as all prevailing safety regulations and accident prevention rules.

2.5 CE conformity

VEGAPULS 68 is in CE conformity with EMC (89/336/ EWG), fulfils the Namur recommendation NE 21 and is in CE conformity with NSR (73/23/EWG).

Conformity has been judged acc. to the following standards:

- EMC:
 - Emission EN 61326: 1997 (class B)
 - Susceptibility EN 61326: 1997/A1: 1998
- NSR: EN 61010-1: 2001.

2.6 Compatibility acc. to NAMUR NE 53

VEGAPULS 68 meets NAMUR recommendation NE 53. VEGA instruments are generally upward and downward compatible:

- sensor software of DTM VEGAPULS 68 HART, PA or FF
- DTM VEGAPULS 68 for adjustment software PACTware™
- adjustment module PLICSCOM for sensor software

The parameter adjustment of the basic sensor functions is independent of the software version. The available functions depend on the appropriate software version of the single components.

The software version of VEGAPULS 68 can be determined as follows:

- via PACTware™
- on the type label of the electronics
- via the adjustment module PLICSCOM

On our website www.vega.com you will find all software histories. Use the possibility and get registered for update information via e-mail.

2.7 FCC conformity (only for USA/Canada)

VEGAPULS with all antenna versions are FCC approved.

Modifications must be expressly agreed by VEGA, otherwise the operating licence acc. to FCC will expire.

VEGAPULS 68 is in conformity with part 15 of the FCC regulations. Note the respective regulations for operation:

- The instrument must not cause any interfering emissions
- The instrument must be insensitive to interfering emissions, also to such causing unwanted operating conditions.

2.8 Safety information for Ex areas

Please note the Ex-specific safety information for installation and operation in Ex areas. These safety instructions are part of the operating instructions manual and come with the Ex-approved instruments.

2.9 Environmental instructions

Protection of the environment is one of our most important duties. That is why we have introduced an environment management system with the goal of continuously improving company environmental protection. The environment management system is certified acc. to DIN EN ISO 14001.

Please help us fulfil this obligation by observing the environmental instructions in this manual:

- Chapter "Storage and transport"
- Chapter "Disposal"

3 Product description

3.1 Configuration

Scope of delivery

The scope of delivery encompasses:

- VEGAPULS 68 radar sensor
- documentation
 - this operating instructions manual
 - Ex-specific safety instructions (with Ex versions) and, if necessary, further certificates

Components

VEGAPULS 68 consists of the following components:

- horn or parabolic antenna
- process fitting (depending on the version flange or thread)
- optionally available with swivelling holder (only with flange), rinsing air connection, reflux valve
- housing with electronics
- housing cover, optionally available with indicating/adjustment module PLICSCOM

The components are available in different versions.

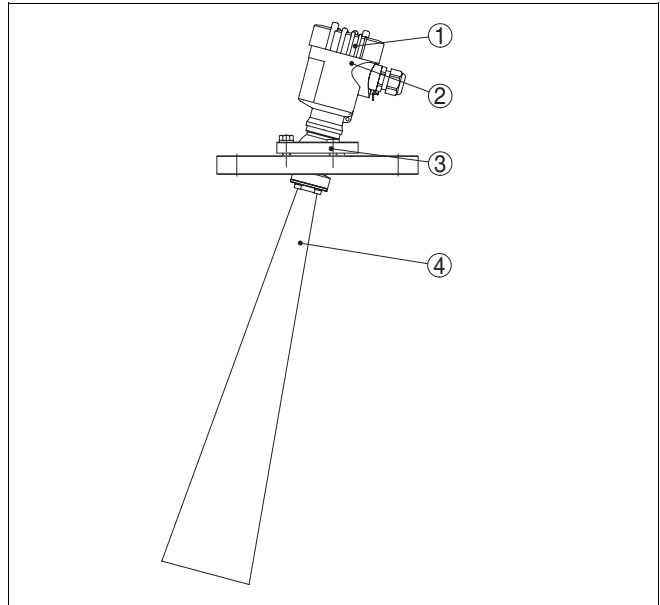

Fig. 1: VEGAPULS 68 with horn antenna and swivelling holder

- 1 Housing cover with integrated PLICSCOM (optional)
- 2 Housing with electronics
- 3 Swivelling holder with flange
- 4 Horn antenna

3.2 Principle of operation

Area of application

VEGAPULS 68 is a radar sensor in K-band technology for continuous level measurement.

A version of VEGAPULS 68 is available for the respective application:

- The version with horn antenna is particularly suitable for small silos and vessels for measurement of virtually all solids.
- The version with parabolic antenna is particularly suitable for large silos and vessels with up to 70 m (76 yd) measuring distance and for measurement of solids with small dielectric value.

Physical principle

The antenna of the radar sensor emits short radar pulses with a duration of approx. 1 ns. These pulses are reflected by the product and received by the antenna as echoes. The running time of the radar pulses from emission to reception is proportional to the distance and hence to the level. The determined level is converted into an appropriate output signal and outputted as measured value.

Power supply

Two-wire electronics 4 ... 20 mA/HART for power supply and measured value transmission on the same cable.

The power supply range can differ depending on the instrument version. The exact range is stated in the Technical data in the Supplement.

3.3 Adjustment

VEGAPULS 68 can be adjusted with three different adjustment media:

- the indicating and adjustment module PLICSCOM
- an adjustment software acc. to FDT/DTM standard, e.g. PACTware™ and PC
- a HART handheld

The entered parameters are generally saved in VEGA-PULS 68, optionally also in PLICSCOM or in PACTware™.

3.4 Storage and transport**Packaging**

Your instrument was protected by packaging during transport. Its capacity to handle normal loads during transport is assured by a test acc. to EN 24180.

The packaging of standard instruments consists of environment-friendly, recyclable cardboard. For special versions PE foam or PE foil can be also used. Dispose of the packaging material via specialised recycling companies.

Storage and transport temperature

- Storage and transport temperature see Supplement, Technical data, Ambient conditions
- Relative humidity 20 ... 85 %

4 Mounting

4.1 General instructions

Installation position

Select an installation position you can easily reach for mounting and connecting as well as later retrofitting of an indicating and adjustment module PLICSCOM. The housing can be rotated by 330° without the use of any tools. You can also install the indicating and adjustment module PLICSCOM in four different positions (each displaced by 90°).

Moisture

Use the recommended cable (see chapter "*Connecting to power supply*") and tighten the cable entry.

You can give your VEGAPULS 68 additional protection against moisture penetration by leading the connection cable downward in front of the cable entry. Rain and condensation water can thus drain off. This applies mainly to mounting outdoors, in areas where moisture is expected (e.g. by cleaning processes) or on cooled or heated vessels.

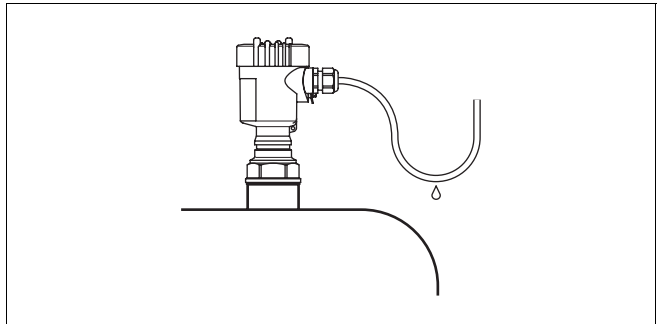

Fig. 2: Measures against moisture penetration

Measuring range

The reference plane for the measuring range is the lower edge of the flange or the seal surface of the thread.



Information:

If the product reaches the antenna, buildup can form on it over a period of time and later cause measurement errors.

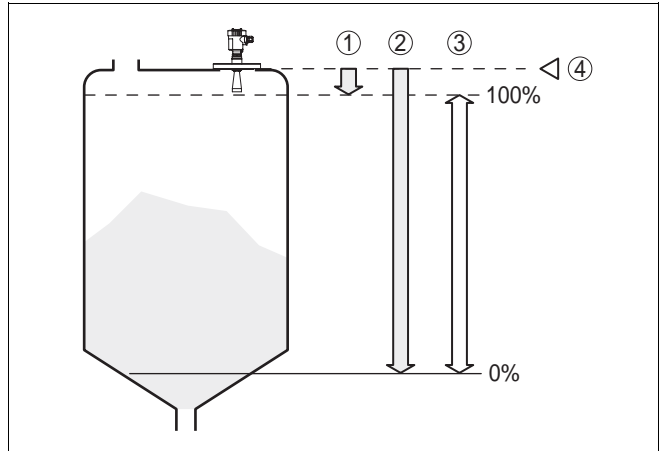

Fig. 3: Measuring range (operating range) and max. measuring distance

- 1 full
- 2 empty (max. measuring distance)
- 3 Measuring range

Pressure

The process fitting must be sealed with gauge or low pressure in the vessel. Check before use, if the seal material is resistant against the measured product. The max. permissible pressure is stated in the Technical data in the Supplement or on the type label of the sensor.

4.2 Mounting preparations, horn antenna



Information:

This information applies only to special versions!

VEGAPULS 68 is available in versions where the **antenna has a bigger diameter** than the process fitting (thread/flange). Therefore the antenna must be dismounted on the process fitting before mounting.

Proceed as follows:

- 1 Loosen the hexagon screws on the antenna socket (1) with an Allan key (size 3)
- 2 Remove the antenna (2)

- 3 Insert the antenna from below into the vessel socket and secure it against falling off
- 4 Retighten the antenna with hexagon screws (1) to the antenna socket; torque max. 10 Nm (7.5 lbf ft)

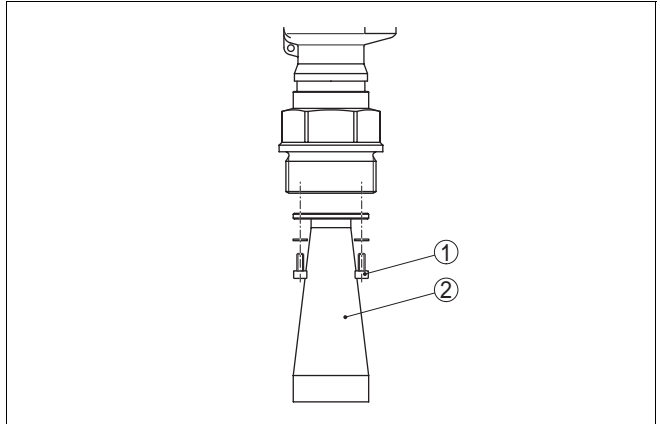

Fig. 4: Dismounting of the horn antenna

- 1 Hexagon screws on the antenna socket
- 2 Antenna

4.3 Mounting preparations, parabolic antenna



Information:

This information applies only to special versions!

VEGAPULS 68 is available in versions where the **antenna has a bigger diameter** than the process fitting (thread/flange). Before starting to mount, the antenna must be dismounted on the flange. Proceed as follows:

- 1 Clamp VEGAPULS 68 with the flange, e.g. in a bench vice
- 2 Hold the connection piece (3) with a wrench SW 22 on the flattenings
- 3 Unscrew the locknut (2) with SW 36 against the antenna
- 4 Unscrew the compression nut (1) with a wrench SW 41 against the antenna

- 5 Remove the parabolic antenna (4) axially
- 6 Mount sensor flange to the adapter flange and clamp it
- 7 Check if there is a O-ring seal on the adapter and if it is not damaged. If necessary, replace it: Viton, article no. 2.28248, Kalrez 6375 article no. 2.27351.
- 8 Remount the parabolic antenna (4)
- 9 Tighten compression nut (3) with SW 41, torque max. 50 Nm.
- 10 Tighten locknut (2) with SW 36, torque max. 40 Nm.

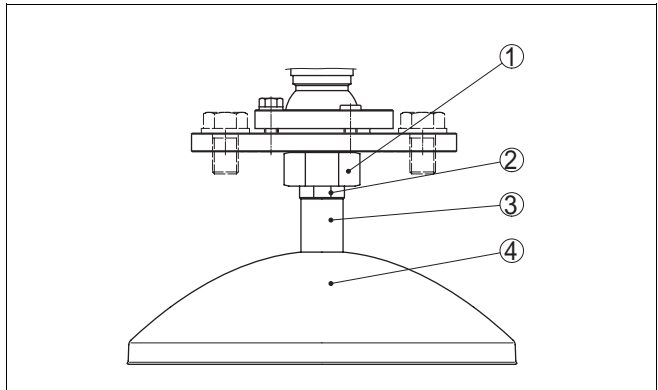

Fig. 5: Dismounting, parabolic antenna

- 1 Compression nut
- 2 Locknut
- 3 Connection piece
- 4 Parabolic antenna

4.4 Mounting information

Horn and parabolic antenna

The illustrations on the mounting instructions show a VEGAPULS 68 with horn antenna. The mounting instructions also apply to VEGAPULS 68 with parabolic antenna.

Installation location

When mounting the sensor, keep a distance of at least 200 mm (7.9 in) to the vessel wall. If the sensor is installed in the center of concave or arched vessel tops, multiple echoes can arise. These can, however, be faded out by an appropriate adjustment (see Setup).

If this distance cannot be maintained, a false echo storage should be carried out during setup. This applies particularly if buildup on the vessel wall is expected. In this case, we recommend repeating the false echo storage later on with existing buildup.

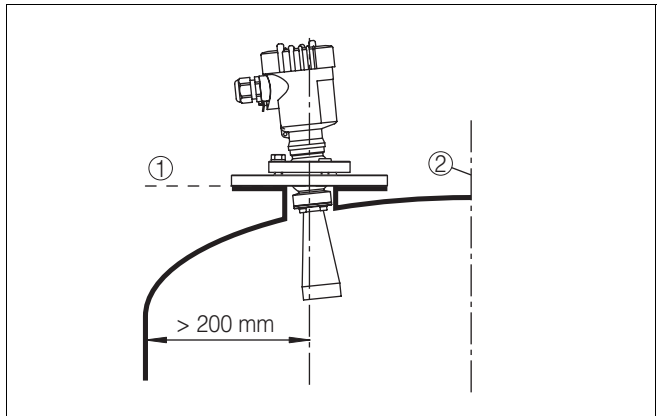

Fig. 6: Installation location

1 Reference plane

In vessels with conical bottom it can be advantageous to align the sensor to the center of the vessel, as measurement is then possible down to the lowest points of the vessel bottom.

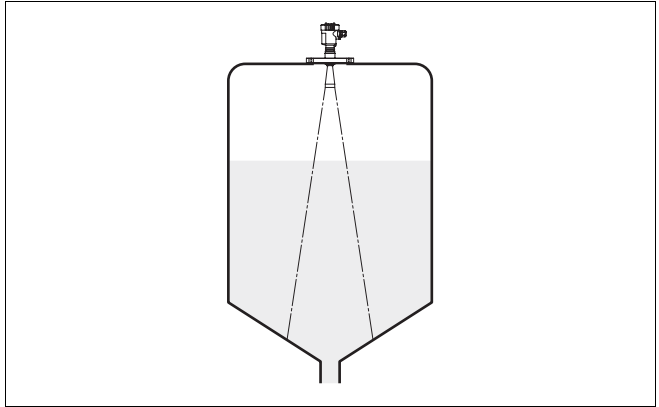

Fig. 7: Vessel with conical bottom

Inflowing material

Do not mount the instruments in or above the filling stream. Make sure that you detect the product surface and not the inflowing product.

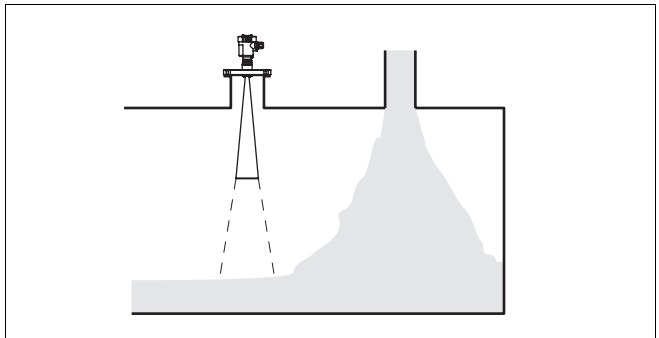

Fig. 8: Inflowing material

Mounting boss

Preferably VEGAPULS 68 should be mounted without socket flush to the vessel top.

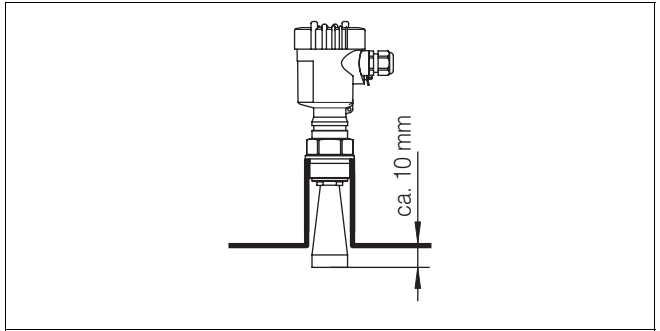

Fig. 9: Recommended socket mounting

If the reflective properties of the medium are good, you can mount VEGAPULS 68 on a socket piece. The socket end should be smooth and burr-free, if possible also rounded. Carry out a false echo storage.

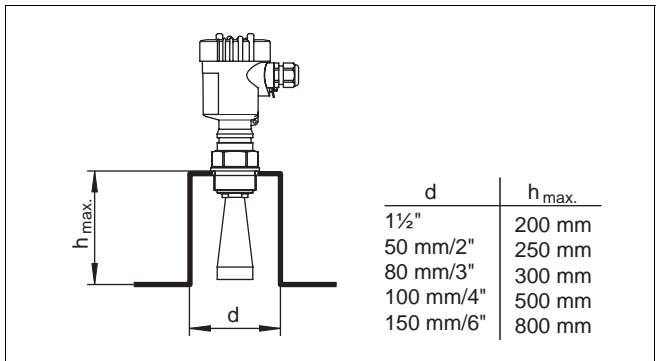

Fig. 10: Deviating socket dimensions

Sensor orientation

In liquids, direct the sensor as close as vertical to the product surface to achieve optimum measurement results.

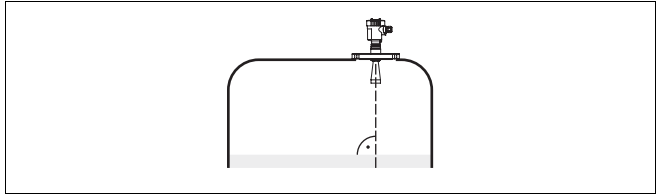

Fig. 11: Orientation in liquids

The version with swivelling holder ensures optimum orientation of the sensor to the solid cone.

Loosen the screw on the swivelling holder with a flat wrench SW 13, direct the sensor and retighten the screw, torque max. 20 Nm.

Vessel installations

The radar sensor should be installed at a location where no installations cross the radar signals.

Vessel installations such as, for example, ladders, limit switches, heating spirals, struts, etc. can cause false echoes superimposed on the useful echo. Make sure when planning your measuring location that the radar signals have "free access" to the measured product.

In case of existing vessel installations, a false echo storage should be carried out during setup.

If large vessel installations such as struts or supports cause false echoes, these can be attenuated through supplementary measures. Small, inclined sheet metal baffles above the installations scatter the radar signals and avoid a direct false echo reflection.

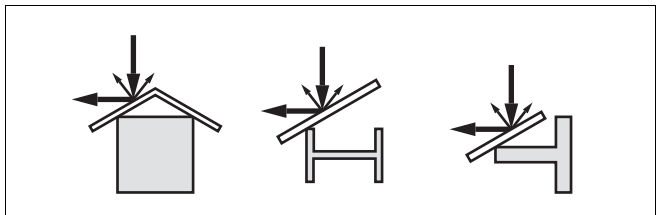

Fig. 12: Cover smooth profiles with deflectors

Material heaps

Large material heaps are detected with several instruments, which can be mounted on e.g. traverse cranes. For this type of application, it is best to orient the sensor toward the solid surface.

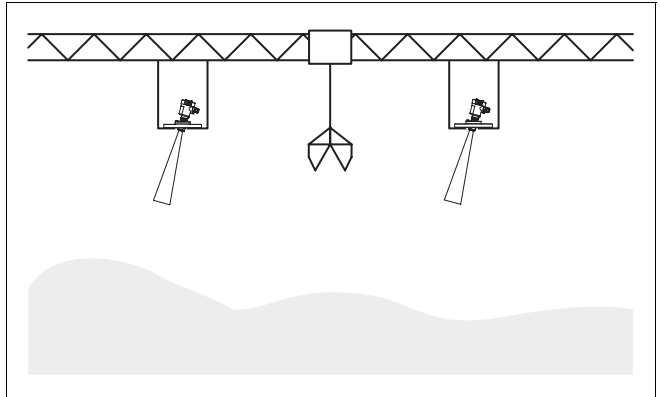

Fig. 13: Radar sensors on traverse crane

5 Connecting to power supply

5.1 Preparing the connection

Note safety instructions

Always observe the following safety instructions:

- Connect only in the complete absence of line voltage
- If overvoltages are expected, overvoltage arresters should be installed.



Tip:

We recommend VEGA overvoltage arresters ÜS-F-LB-I and ÜSB 62-36G.X.

Take note of safety instructions for Ex applications



In hazardous areas you should take note of the appropriate regulations, conformity and type approval certificates of the sensors and power supply units.

Select power supply

Power supply and current signal are transmitted via the same two-wire connection cable. The power supply range can differ depending on the instrument version. The exact range is stated in the Technical data in the Supplement.

Provide a reliable separation between the supply circuit and the mains circuits acc. to DIN VDE 0106 part 101. The VEGA power supply units VEGATRENN 149AEx, VEGASTAB 690, VEGADIS 371 as well as all VEGA-METs meet this requirement.

Bear in mind the following factors regarding supply voltage:

- the reduction of the output voltage of the power supply unit under nominal load (with a sensor current of 20.5 mA or 22 mA in case of fault signal)
- the influence of additional instruments in the circuit (see load values in Technical data)

Select connection cable

VEGAPULS 68 is connected with standard two-wire cable without screen. An outer cable diameter of 5 ... 9 mm ensures the seal effect of the cable entry. If electromagnetic interference is expected, we recommend the use of screened cable.

Cable screening and grounding

Connect the cable screen on both ends to ground potential. In the sensor, the screen must be connected directly to the internal ground terminal. The ground terminal outside on the housing must be connected to the potential equalisation (low impedance).

If potential equalisation currents are expected, the connection on the evaluation side must be made via a ceramic capacitor (e.g. 1 nF, 1500 V). The low frequency potential equalisation currents are thus suppressed, but the protective effect against high frequency interference signals remains.

Select connection cable for Ex applications



Take note of the corresponding installation regulations for Ex applications. In particular, make sure that no potential equalisation currents flow over the cable screen. In case of grounding on both sides this can be achieved by the use of a capacitor or a separate potential equalisation.

5.2 Connection procedure

Proceed as follows:

- 1 Unscrew the housing cover
- 2 If a PLICSCOM indicating and adjustment module is installed, remove it by turning it slightly to the left.
- 3 Loosen compression nut of the cable entry
- 4 Remove approx. 10 cm (4 in) of the cable mantle, strip approx. 1 cm (0.4 in) insulation from the ends of the individual wires
- 5 Insert the cable into the sensor through the cable entry
- 6 Lift the opening levers of the terminals with a screwdriver (see following illustration)
- 7 Insert the wire ends into the open terminals according to the wiring plan
- 8 Press down the opening levers of the terminals, you will hear the terminal spring closing

- 9 Check the hold of the wires in the terminals by lightly pulling on them
 - 10 Connect the screen to the internal ground terminal and the external ground terminal to potential equalisation
 - 11 Tighten the compression nut of the cable entry, the seal ring must completely encircle the cable
 - 12 Screw the housing cover back on
- The electrical connection is finished.



Fig. 14: Connection steps 6 and 7

5.3 Wiring plans, single chamber housing



The following illustrations apply to the non-Ex as well as to the Ex ia version.

Housing overview

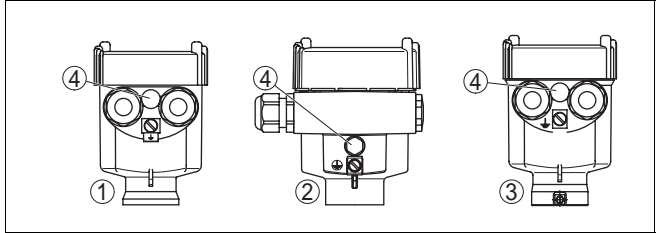

Fig. 15: Material versions, single chamber housing

- 1 Plastic
- 2 Aluminium
- 3 Stainless steel
- 4 Filter element for pressure compensation

Electronics and connection compartment

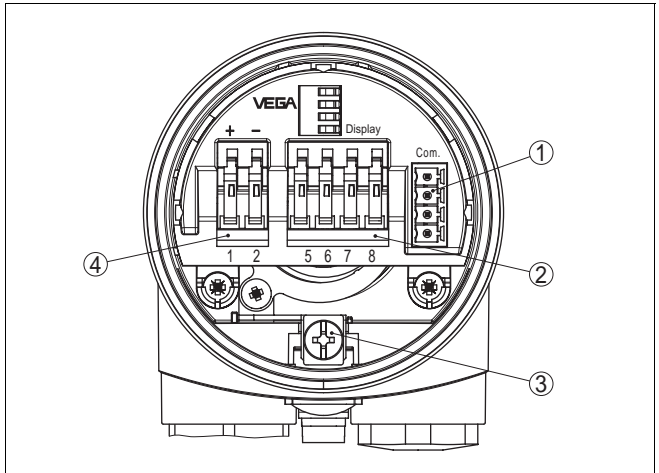

Fig. 16: Electronics and connection compartment, single chamber housing

- 1 Plug connector for VEGACONNECT (I²C interface)
- 2 Spring-loaded terminals for connection of the ext. indication VEGADIS 61
- 3 Ground terminal for connection of the cable screen
- 4 Spring-loaded terminals for power supply and cable screen

Wiring plan

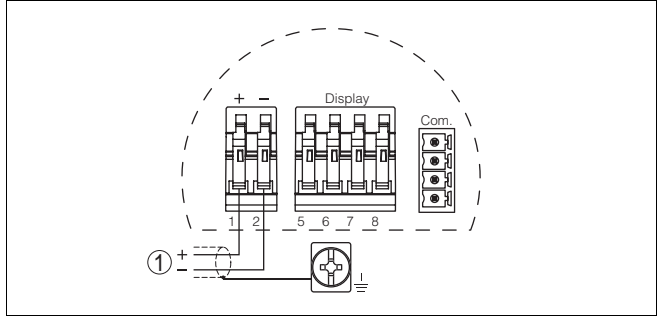

Fig. 17: Wiring plan, single chamber housing

1 Power supply/Signal output

5.4 Wiring plans, double chamber housing



The following illustrations apply to the non-Ex as well as to the Ex ia version. The Exd version is described in the next subchapter.

Housing overview

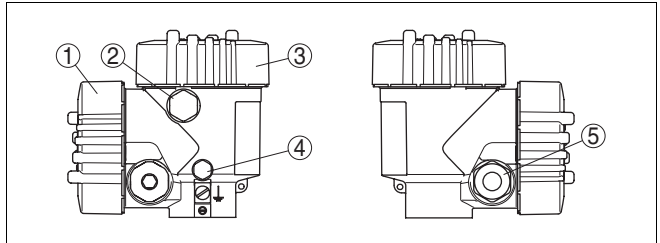

Fig. 18: Double chamber housing

- 1 Housing cover, connection compartment
- 2 Blind stopper or plug M12x1 for VEGADIS 61 (option)
- 3 Housing cover, electronics compartment
- 4 Filter element for pressure compensation
- 5 Cable entry or plug

Electronics compartment

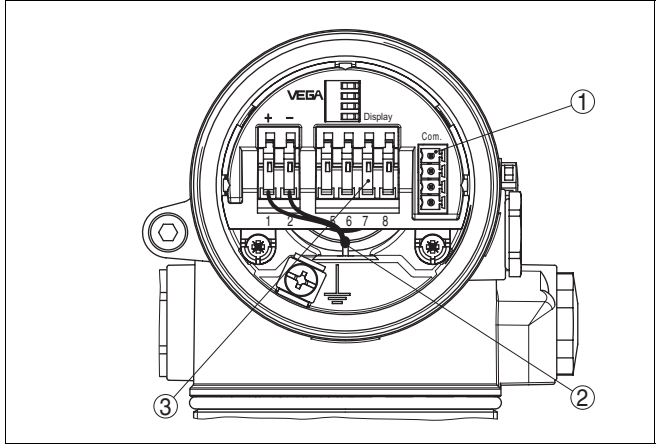

Fig. 19: Electronics compartment, double chamber housing

- 1 Plug connector for VEGACONNECT (I²C interface)
- 2 Internal connection cable to the connection compartment
- 3 Terminals for VEGADIS 61

Connection compartment

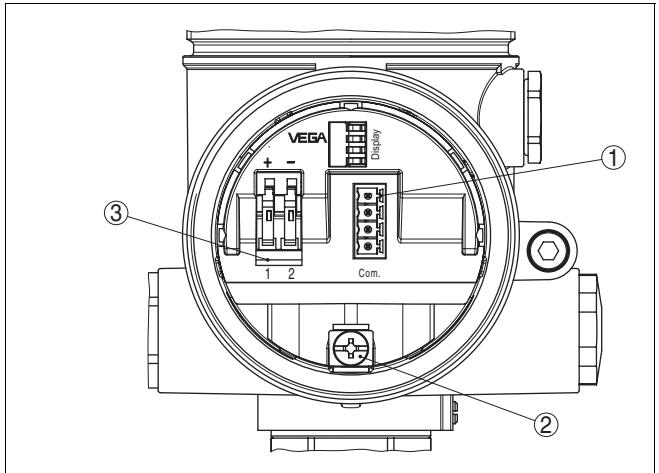

Fig. 20: Connection compartment, double chamber housing

- 1 Plug connector for VEGACONNECT (I²C interface)
- 2 Ground terminal for connection of the cable screen
- 3 Spring-loaded terminals for power supply and cable screen

Wiring plan

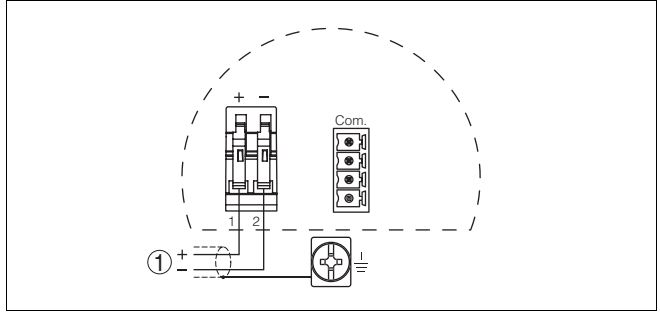

Fig. 21: Connection compartment, double chamber housing
1 Power supply/Signal output

5.5 Wiring plans, double chamber housing Exd

Housing overview

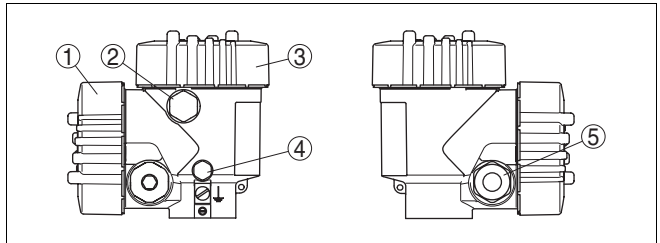

Fig. 22: Double chamber housing
1 Housing cover, connection compartment
2 Blind stopper or plug M12x1 for VEGADIS 61 (option)
3 Housing cover, electronics compartment
4 Filter element for pressure compensation
5 Cable entry or plug

Electronics compartment

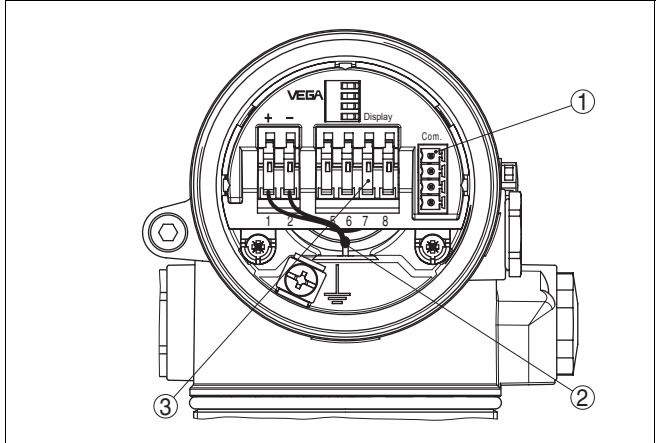

Fig. 23: Electronics compartment, double chamber housing

- 1 Plug connector for VEGACONNECT (I²C interface)
- 2 Internal connection cable to the connection compartment
- 3 Terminals for VEGADIS 61

Connection compartment

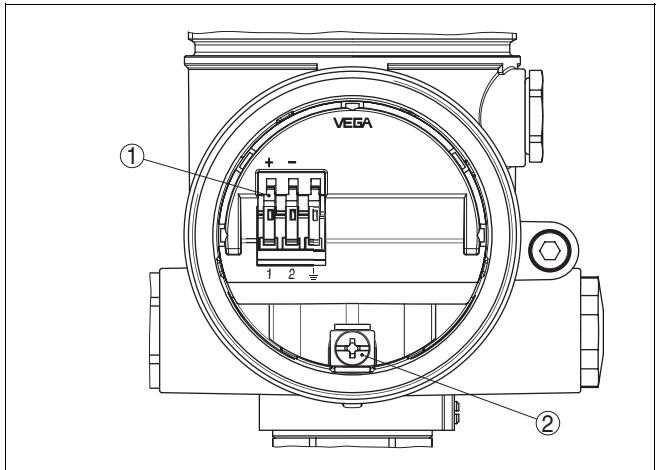

Fig. 24: Connection compartment, double chamber housing Exd

- 1 Spring-loaded terminals for power supply and cable screen
- 2 Ground terminal for connection of the cable screen

Wiring plan

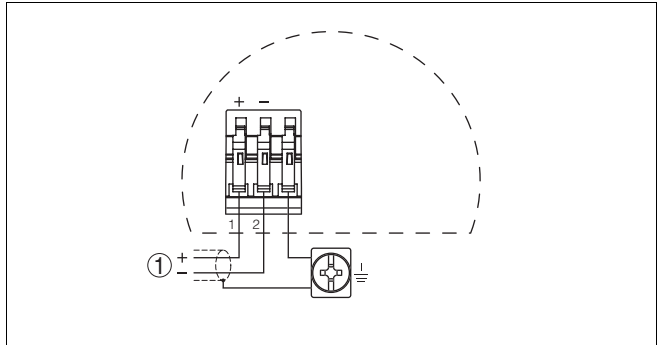

Fig. 25: Wiring plan, double chamber housing Exd

1 Power supply/Signal output

6 Setup with the indicating and adjustment module PLICSCOM

6.1 Short description

Function/Configuration

The indicating and adjustment module PLICSCOM is used for measured value display, adjustment and diagnosis. It can be mounted in the following housing versions and instruments:

- All sensors of the plics[®] instrument family, in the single as well as in the double chamber housing (optionally in the electronics or connection compartment)
- external indicating and adjustment unit VEGADIS 61



Note:

You will find detailed information on the adjustment in the operating instructions manual of the indicating and adjustment module PLICSCOM.

6.2 Installing the indicating and adjustment module PLICSCOM

Insert/remove PLICSCOM

PLICSCOM can be inserted or removed at any time. An interruption of the power supply is not necessary.

To install, proceed as follows:

- 1 Unscrew the housing cover
- 2 Place PLICSCOM in the desired position on the electronics (you can choose any one of four different positions - each displaced by 90°)
- 3 Press PLICSCOM lightly onto the electronics and turn it to the right until it snaps in.
- 4 Screw housing cover with inspection window tightly back on

Removal is carried out in reverse order.

PLICSCOM is powered by the sensor, an additional connection is not necessary.



Fig. 26: Installation of PLICSCOM



Note:

If you intend to retrofit VEGAPULS 68 with PLICSCOM for continuous measured value indication, a higher cover with an inspection glass is required.

6.3 Adjustment system

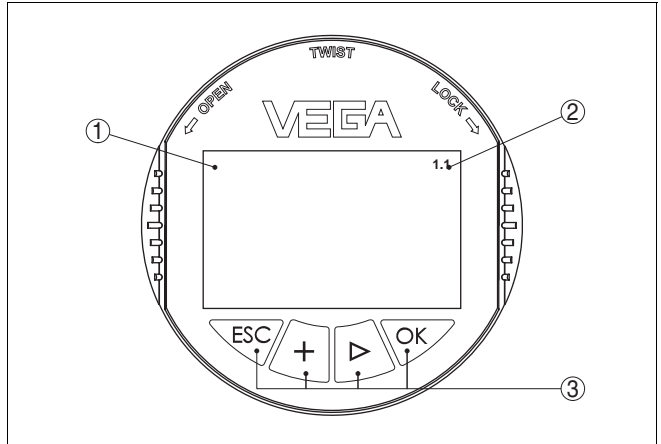

Fig. 27: Indicating and adjustment elements

- 1 LC display
- 2 Indication of the menu item number
- 3 Adjustment keys

Key functions

- **[OK]** key:
 - move to the menu overview
 - confirm selected menu
 - edit parameter
 - save value
- **[→]** key to select:
 - menu change
 - list entry
 - editing position
- **[+]** key:
 - modify value of a parameter
- **[ESC]** key:
 - interrupt input
 - jump to the next higher menu

Adjustment system

The sensor is adjusted via the four keys of the indicating and adjustment module PLICSCOM. The LC display indicates the individual menu items. The functions of the individual keys are shown in the above illustration. Approx. 10 minutes after the last pressing of a key, an automatic reset to measured value indication is trigger-

ed. Any values not confirmed with **[OK]** will not be saved.

6.4 Setup procedure

Switch on phase

After VEGAPULS 68 is connected to power supply or after voltage recurrence, the instrument carries out a self-test for approx. 30 seconds. The following steps are carried out:

- internal check of the electronics
- indication of the instrument type, the firmware version as well as the sensor TAGs (sensor name)
- Output signal jumps briefly (approx. 10 seconds) to the set interference current.

Then the actual measured value is displayed and the corresponding current is transmitted to the cable¹⁾

Address setting HART-Multidrop

In HART-Multidrop mode (several sensors on one input) the address must be set before continuing with the parameter adjustment. You will find a detailed description in the operating instructions manual of PLICSCOM or in the online help of PACTware™ or DTM.

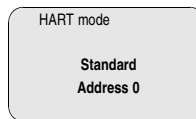

Parameter adjustment

Because VEGAPULS 68 is a distance measuring instrument, the distance from the sensor to the product surface is measured. In order to have the actual level displayed, an allocation of the measured distance to the percentage height must be carried out. To make this adjustment, the full and empty distances in the vessel are entered. If these values are not known, it is also possible to carry out the adjustment with other distances, e.g. 10 % and 90 %. Starting point of these distance values is always the seal surface of the thread or flange. The actual level is then calculated on the basis of these

¹⁾ The values correspond to the actual level as well as to the settings already carried out, e.g. default setting.

entered values. At the same time, the operating range of the sensor is limited from maximum range to the requested range.

The real product level during this adjustment is not important, because the min./max. adjustment is always carried out without changing the product level. These settings can be made ahead of time without the instrument having to be installed.

In the main menu item Basic adjustment, the individual submenu items should be selected one after the other provided with the correct parameter values.

Start your parameter adjustment with the following menu items of the basic adjustment:

Carrying out min. adjustment

Proceed as follows:

- 1 Move from the measured value display to the main menu by pushing **[OK]**.

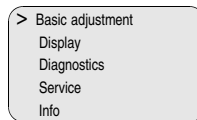

- 2 Select the menu item *Basic adjustment* with **[->]** and confirm with **[OK]**. Now the menu item min. adjustment is displayed.

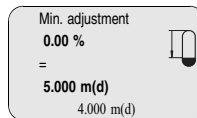

- 3 Prepare the percentage value for editing with **[OK]** and set the cursor to the requested position with **[->]**. Set the requested percentage value with **[+]** and save with **[OK]**. The cursor jumps now to the distance value.
- 4 Enter the appropriate distance value in m (corresponding to the percentage value) for the empty vessel (e.g. distance from the sensor to the vessel bottom).

- 5 Save the settings with **[OK]** and move to max. adjustment with **[->]**.

Carrying out max. adjustment

Proceed as follows:

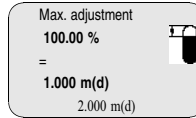

- 1 Prepare the percentage value for editing with **[OK]** and set the cursor to the requested position with **[->]**. Set the requested percentage value with **[+]** and save with **[OK]**. The cursor jumps now to the distance value.
- 2 Enter the appropriate distance value in m (corresponding to the percentage value) for the full vessel. Make sure that the max. level must be beneath the dead zone.
- 3 Save the settings with **[OK]** and move to the medium selection with **[->]**.

Medium selection

Each product has different reflective properties. In solids, these are dust generation, material cones and additional echoes caused by the vessel wall. Due to the medium selection, the sensor is adapted in an optimum way to the product and the accuracy, particularly for products with bad reflective properties, is increased considerably.

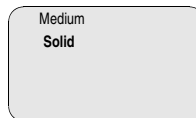

For solids you choose also *Powder/Dust*, *Granular/Pellets* or *Ballast/Pebbels*.

In liquids, fluctuating surfaces and foam generation are further interfering factors. To adapt the sensor to the different conditions, a general selection is made in this menu item, i.e. *Solid* or *Liquid*.

Enter the requested parameter via the respective keys, save your settings and jump to the next menu item with the [->] key.

Vessel form

Apart from the medium also the vessel form can influence the measurement. To adapt the sensor to these conditions, this menu item offers (depending on either liquid or solid is selected) different options. For *Liquid* these are *Storage tank*, *Stilling tube*, *Open vessel* or *Stirred vessel*, for *Solid* *Silo* or *Bunker*.

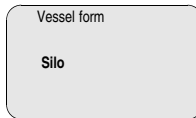

Enter the requested parameter via the respective keys, save your settings and jump to the next menu item with the [->] key.

Damping

To suppress fluctuation in the measured value display, e.g. by agitated product surfaces, an integration time can be set. This time can be between 0 and 999 seconds. Please note that the reaction time of the entire measurement will be longer and the sensor will react to quick changes of the measured value with a corresponding delay. In general, a time of a few seconds is sufficient to smooth the measured value display.

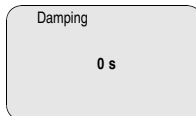

Enter the requested parameter via the respective keys, save your settings and jump to the next menu item with the [->] key.

Linearization curve

A linearization is necessary for all vessels in which the vessel volume does not increase linearly with the level - e.g. in a cylindrical or spherical tank - and the indication or output of the volume is requested. Corresponding linearization curves are preprogrammed for these vessels. They represent the correlation between the level percentage and vessel volume. By activating the

appropriate curve, the volume percentage of the vessel is displayed correctly. If the volume should not be displayed in percent but e.g. in l or kg, a scaling can be set in the menu item *Display*.

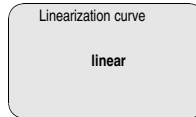

Enter the requested parameter via the respective keys, save your settings and jump to the next menu item with the **[→]** key.

Sensor-TAG

In this menu item you can enter an unambiguous designation for the sensor, e.g. the measurement loop name or the tank or product designation. In digital systems and in the documentation of larger plants, a unique designation should be entered for exact identification of individual measuring sites.

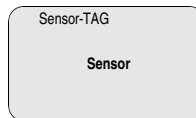

With this menu item, the Basic adjustment is finished and you can now jump to the main menu with the **[ESC]** key.

False echo storage

High sockets or vessel installations, such as e.g. struts or agitators as well as buildup and weld joints on the vessel walls cause false reflections which influence the measurement. A false echo storage detects and marks these false echoes so that they are no longer taken into account for the level measurement. A false echo memory should be created with empty vessel so that all probably existing false reflections can be detected.

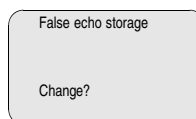

Proceed as follows:

- 1 Move from the measured value display to the main menu by pushing **[OK]**.
- 2 Select the menu item *Service* with **[->]** and confirm with **[OK]**. Now the menu item false echo storage is displayed.
- 3 Confirm *False echo storage - Change now* with **[OK]** and select in the below menu *Create new*. Enter the actual distance from the sensor to the product surface. All false echoes in this area are detected by the sensor and saved after confirming with **[OK]**.

**Note:**

Check the distance to the product surface as in case of a wrong (too big) setting, the real level will be saved as false echo. Hence the level can no longer be detected in this area.

Optional settings

Additional adjustment and diagnosis options such as e. g. scaling, simulation or trend curve presentation are shown in the following menu schematic. You will find a detailed description of these menu items in the operating instructions manual of the indicating and adjustment module PLICSCOM.

6.5 Menu schematic

Basic adjustment

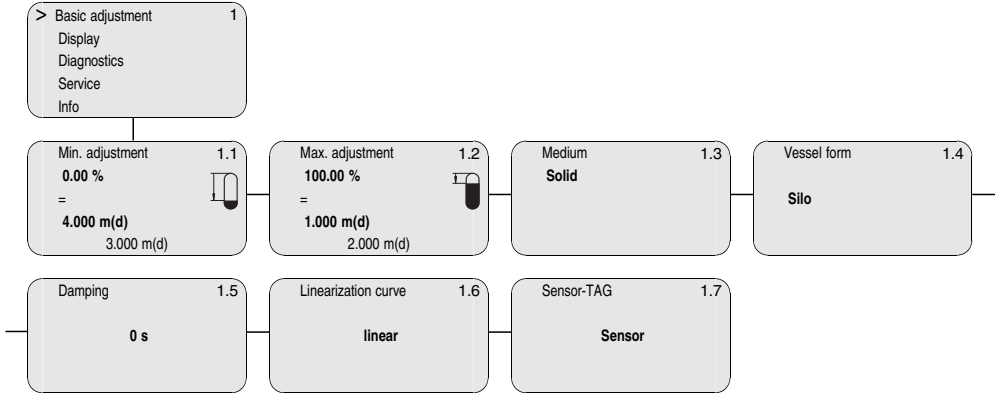

Display

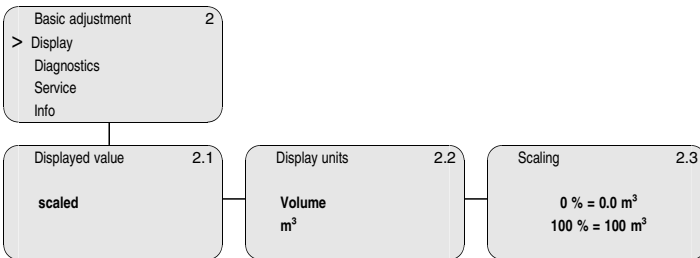

Diagnostics

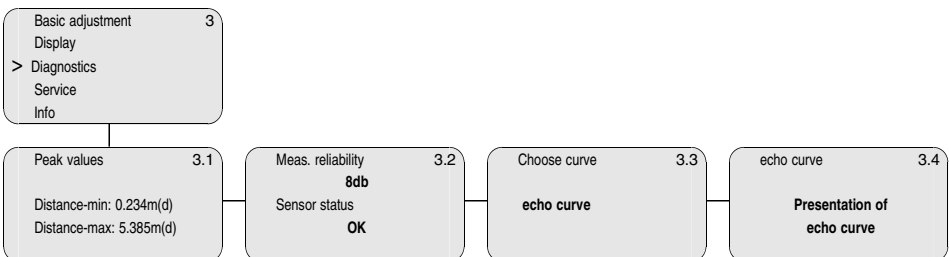

Service

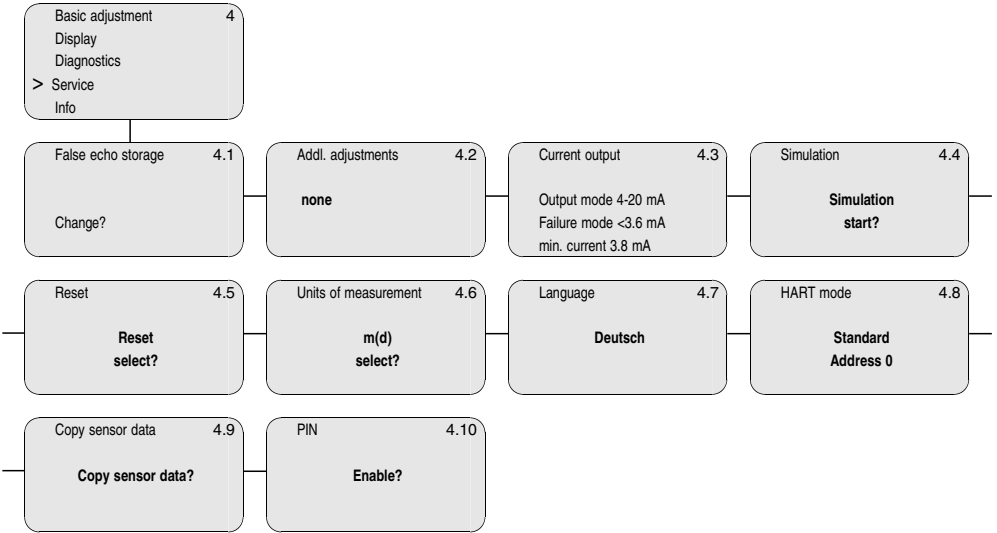

Info

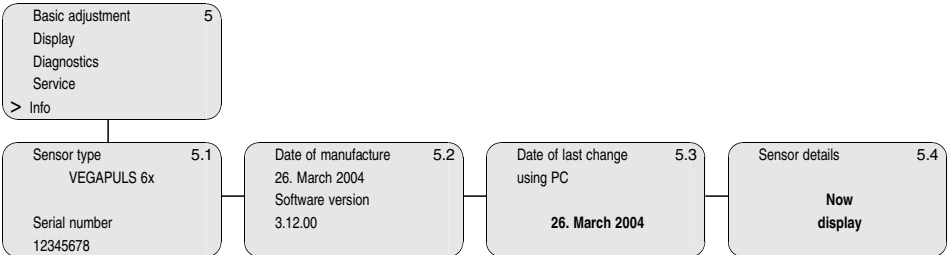

7 Setup with PACTware™

7.1 Connecting the PC

Connecting the PC directly to the sensor

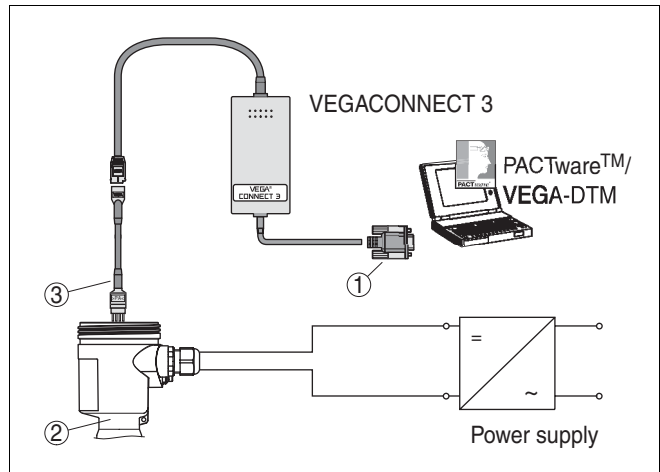

Fig. 28: Connecting the PC directly to the sensor

- 1 RS232 connection
- 2 VEGAPULS 68
- 3 I²C adapter cable for VEGACONNECT 3

Necessary components:

- VEGAPULS 68
- PC with PACTware™ and suitable VEGA-DTM
- VEGACONNECT 3 with I²C adapter cable (article no. 2.27323)
- power supply unit

Connecting the PC to the signal cable

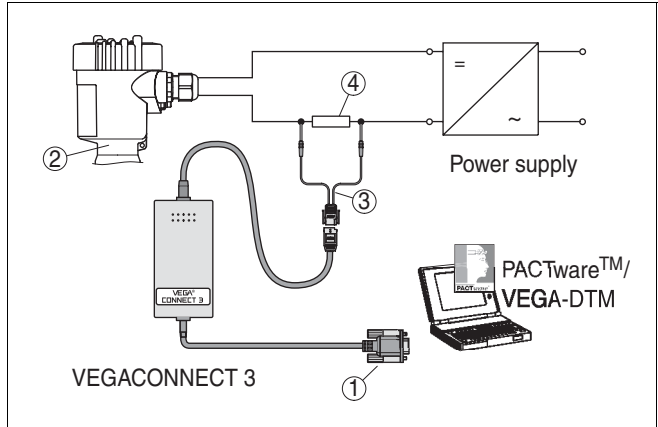

Fig. 29: Connecting the PC to the signal cable

- 1 RS232 connection
- 2 VEGAPULS 68
- 3 HART adapter cable for VEGACONNECT 3
- 4 HART resistance 250 Ohm

Necessary components:

- VEGAPULS 68
- PC with PACTware™ and suitable VEGA-DTM
- VEGACONNECT 3 with HART adapter cable (art. no. 2.25397)
- HART resistance approx. 250 Ohm
- power supply unit



Note:

With power supply units with integrated HART resistance (internal resistance approx. 250 Ohm), an additional external resistance is not necessary (e.g. VEGATRENN 149A, VEGADIS 371, VEGAMET 381). In such cases, VEGACONNECT 3 can be connected in parallel to the 4 ... 20 mA cable.

7.2 Parameter adjustment with PACTware™

Further setup steps are described in the operating instructions manual *DTM Collection/PACTware* attached to each CD and which can also be downloaded

from our homepage. A detailed description is available in the online help of PACTware™ and the VEGA-DTMs.

**Note:**

Keep in mind that for setup of VEGAPULS 68, DTM-Collection 04/2004 or a newer version should be applied.

All currently available VEGA-DTMs are provided in the DTM Collection on CD and can be bought from the responsible VEGA agency for a token fee. This CD includes also the up-to-date PACTware™ version. The basic version of this DTM Collection incl. PACTware™ is also available as a free-of-charge download from the Internet.

8 Maintenance and fault rectification

8.1 Maintenance

When used as directed in normal operation, VEGAPULS 68 is completely maintenance-free.

8.2 Fault rectification

Causes of failure

VEGAPULS 68 offers maximum reliability. Nevertheless, faults may occur during operation. These can have the following causes, e.g.:

- Sensor
- Process
- Power supply
- Signal processing.

Fault rectification

The first measures to be taken are to check the output signal and evaluate fault messages via the adjustment module PLICSCOM. The procedure is described below. Further comprehensive diagnostics can be carried out on a laptop with the software PACTware™ and the suitable DTM. In many cases, the reasons can be determined in this way and faults can be rectified.

24 hour service hotline

Should these measures not be successful, please call in urgent cases the VEGA service hotline under the phone number **+49 1805 858550**.

The hotline is available to you 7 days a week round-the-clock. Since we offer this service world-wide, the support is only available in the English language. The service is free of charge, only the standard telephone costs will be charged.

Checking the 4 ... 20 mA signal

Connect a hand-held multimeter with a suitable measuring range acc. to the wiring plan.

? 4 ... 20 mA signal is not stable

- level fluctuations
- set integration time via PLICSCOM or PACTware™

? 4 ... 20 mA signal missing

- incorrect connection to power supply
 - check connection acc. to chapter "Connection procedure" and correct, if necessary, acc. to chapter "Wiring plans"
- no power supply
 - check cables for line break, repair, if necessary
- supply voltage too low or load resistance too high
 - check and adapt, if necessary

? Current signal greater than 22 mA or less than 3.6 mA

- Electronics module defective
 - exchange instrument or return it for repair



In Ex applications, the regulations for the wiring of intrinsically safe circuits must be observed.

Fault messages via PLICSCOM**? E013**

- no measured value available
 - sensor in boot phase
 - sensor does not find an echo, e.g. through incorrect installation or wrong parameter adjustment

? E017

- adjustment span too small
 - Carry out a fresh adjustment and increase the distance between min. and max. adjustment

? E036

- no operable sensor software
- carry out a software update or return instrument for repair

? E041

- hardware error, electronics defective
- exchange instrument or return it for repair

8.3 Exchanging the oscillator**Preparations**

If the electronics module is defective, it can be replaced by the user

Oscillator PS-E.60SH. is suitable for VEGAPULS 68 – 4 ... 20 mA/HART. The following versions are available:

- PS-E.60SHX (without approvals)
- PS-E.60SHC (approvals XM, CX, CM, CK, CI, DX, DM, DK, DI; EX, GX, UX, UF acc. to VEGA product list)



In Ex applications, only an oscillator with appropriate Ex approval must be used.

If there is no oscillator available on site, it can be ordered from the responsible VEGA agency.

The new oscillator must be according to the order data of the sensor. These can be loaded as follows:

- at the premises by VEGA
- on site by the user.

**Information:**

When loading on site, first of all the respective file must be downloaded from the Internet (see *Setup*).

In both cases, the serial number of VEGAPULS 68 is necessary. The serial numbers are stated on the type label of VEGAPULS 68 or on the delivery note.

Exchange

Proceed as follows:

- 1 Switch off power supply
- 2 Unscrew the housing cover
- 3 Lift the opening levers of the terminals with a screwdriver
- 4 Pull the connection cables out of the terminals
- 5 Loosen the two screws with a Phillips screwdriver (size 1)

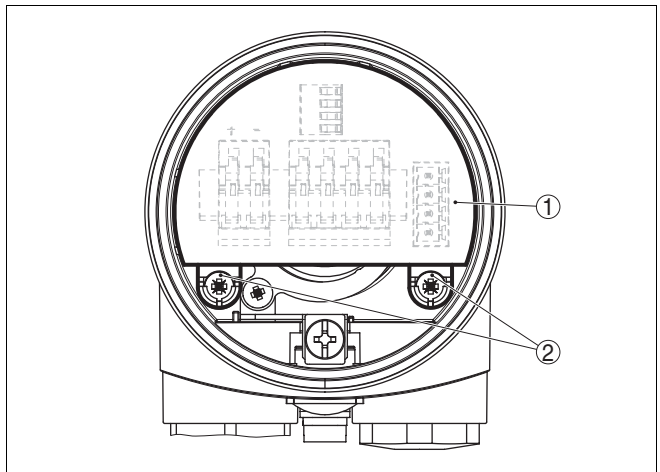

Fig. 30: Loosen the screws

- 1 Electronics module
- 2 Screws (2 pcs.)

- 6 Pull the existing oscillator out by holding the opening levers.
- 7 Compare the new oscillator with the old one. The statements on the type label must correspond. This applies particularly to instruments in Ex areas.
- 8 Insert the oscillator
- 9 Screw in and tighten the two screws with a Phillips screwdriver.
- 10 Insert the wire ends into the open terminals according to the wiring plan

- 11 Close the opening levers of the terminals, you will hear the terminal spring closing
 - 12 Check the hold of the wires in the terminals by lightly pulling on them
 - 13 Check the tightness of the cable entry. The seal ring must completely encircle the cable.
 - 14 Screw the housing cover back on
- The electronics exchange is finished.



Setup

As a rule, the exchange of the oscillator must be documented internally when used in Ex applications.

If the serial number of the oscillator is stated when ordering, VEGAPULS 68 is ready for operation directly after mounting the oscillator.

If you are using an universal electronics from stock, you have to load the sensor data after mounting the oscillator. Use the item "serial number search" under www.vega.com. After having entered the serial number, the order data of the sensor will be displayed. Below the order data you will find "Sensor data for Service-DTM" as an XML file. Load this file to your PC and then into the sensor via PACTware™/Service DTM.

After VEGAPULS 68 is ready for operation, settings carried out on site must be repeated.



Tip:

Use the copy function of the adjustment module PLICSCOM or the adjustment software PACTware™.

8.4 Instrument repair

If it is necessary to repair VEGAPULS 68 please proceed as follows:

You can download a return form (23 KB) from our Internet homepage www.vega.com under "Services > Downloads > Forms and Certificates > Repair form.

By doing this you help us carry out the repair quickly and without having to call for additional information.

- Print and fill out one form per instrument
- Clean the instrument and pack it damage-proof
- Attach the completed form and possibly also a safety data sheet to the instrument
- Send the instrument to the respective address of your agency. In Germany to the VEGA headquarters in Schiltach.

9 Dismounting

9.1 Dismounting procedure

**Warning:**

Before dismounting, be aware of dangerous process conditions such as e.g. pressure in the vessel, high temperatures, corrosive or toxic products etc.

Take note of chapters "Mounting" and "Connecting to power supply" and carry out the listed steps in reverse order.

9.2 Disposal

VEGAPULS 68 consists of materials which can be recycled by specialised recycling companies. We have purposely designed the electronic modules to be easily separable. Mark the instrument as scrap and dispose of it according to government regulations (electronic scrap ordinance, ...)

Materials: see Technical data

If you cannot dispose of the instrument properly, please contact us about disposal methods or return.

10 Supplement

10.1 Technical data

General data

Materials, non-wetted parts

- housing plastic PBT (Polyester), Alu-die casting powder-coated, 316L (stainless steel 1.4435)
- seal ring between housing and housing cover NBR (stainless steel housing), silicone (Alu/plastic housing)
- inspection window in housing cover for PLICSCOM Polycarbonate
- ground terminal stainless steel 1.4571/1.4435

Materials, wetted parts

- process fitting thread G1½A and 1½ NPT, flanges DN 50 ... DN 200 and 2" ... 8": 316 L (stainless steel 1.4435)
- Antenna 316 L (stainless steel 1.4435), PTFE (TFM 1600 PTFE)
- seal, antenna system Viton, Kalrez 2035, 6230, 6375, 6623

Weight with horn antenna

- process fitting, thread 2.0 ... 2.8 kg (4.4 ... 6.2 lbs), depending on the thread size and housing
- process fitting, flange 4.2 ... 15.4 kg (9.3 ... 34 lbs), depending on the flange size and housing
- process fitting swivelling holder with flange 5.2 ... 16.4 kg (11.5 ... 35.2 lbs), depending on the flange size and housing

Weight with parabolic antenna

- process fitting, thread 2.8 ... 3.6 kg (6.2 ... 13.7 lbs), depending on the thread size and housing
- process fitting, flange 5.0 ... 16.2 kg (11 ... 35.7 lbs), depending on the flange size and housing
- process fitting swivelling holder with flange 6.0 ... 17.2 kg (13.2 ... 37.9 lbs), depending on the flange size and housing

Output variable

Output signal	4 ... 20 mA/HART
Resolution	1.6 μ A
Fault signal	current output unchanged, 20.5 mA, 22 mA, < 3.6 mA (adjustable)
Current limitation	22 mA
Load	see load diagram in Power supply
Integration time (63% of the input variable)	0 ... 999 s, adjustable
Rise time	150 ms (ti: 0 s, 0 ... 100 %)
Fulfilled Namur recommendation	NE 43

Input variable

Parameter	distance between process fitting and product surface
Min. distance from antenna end	400 mm (15.7 in)
max. measuring range	60 m (197 ft), optionally 70 m (230 ft)

Accuracy (similar to DIN EN 60770-1)

Reference conditions acc. to DIN EN 61298-1

– temperature	18 ... 30°C (64 ... 86°F)
– relative humidity	45 ... 75 %
– pressure	860 ... 1060 mbar (86 ... 106 kPa or 12.5 ... 15.4 psi)

Characteristics curve deviation and measurement characteristics²⁾

Average temperature coefficient of the zero signal (temperature error)	0.06 %/10 K
Resolution, general	max. 1 mm
Frequency	K-band
Interval	> typ. 4 s
Adjustment time ³⁾	

²⁾ Relating to the nominal range, incl. hysteresis and repeatability, determined acc. to the limit point method.

³⁾ Time to output the correct level (with max. 10 % deviation) after a sudden level change.

	> 4 s (dependent on the parameter adjustment)
Received average emitted power reaching an object directly in front of the antenna	
– distance 1 m	108 nW per cm ² (108 x 10 ⁻⁹ W/cm ²)
– distance 5 m	4.3 nW per cm ² (4,3 x 10 ⁻⁹ W/cm ²)
Beam angle with horn antenna, depending on the antenna diameter	
– ø 40 mm	22°
– ø 48 mm	18°
– ø 75 mm	10°
– ø 95 mm	8°
Beam angle with parabolic antenna	3.5 °
Accuracy	see diagram

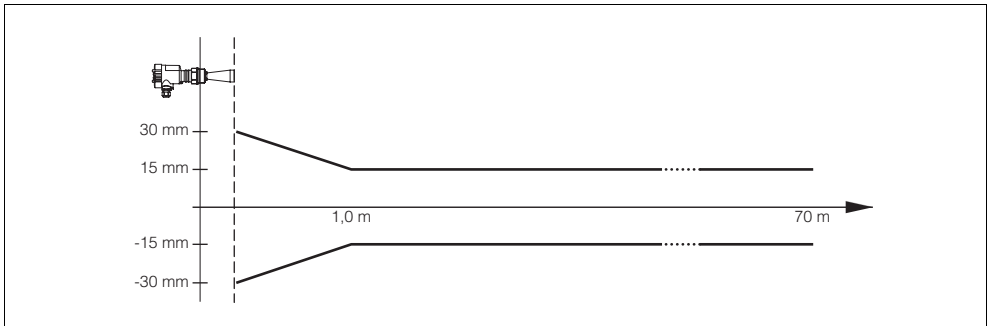

Fig. 31: Accuracy VEGAPULS 68

Ambient conditions

Ambient, storage and transport temperature

- without PLICSCOM -40 ... +80°C (-40 ... +176°F)
- with PLICSCOM -20 ... +70°C (-4 ... +158°F)

Process conditions

Vessel pressure horn antenna

- without swivelling holder -1 ... 40 bar (-100 ... 4000 kPa or -14.5 ... 580)
- with swivelling holder -1 ... 1 bar (-100 ... 100 kPa or -14.5 ... 14.5 psi) not sealing

vessel pressure parabolic antenna

- without swivelling holder -1 ... 6 bar (-100 ... 4000 kPa or -14.5 ... 87 psi)
- with swivelling holder -1 ... 1 bar (-100 ... 100 kPa or -14.5 ... 14.5 psi) not sealing

Process temperature (measured on the process fitting) depending on the seal of the antenna system

- Viton -40 ... +130°C (-40 ... +266°F)
- Viton with temperature adapter -40 ... +200°C (-40 ... +392°F)
- Kalrez 2035, 6230, 6623 -15 ... +130°C (-5 ... +266°F)
- Kalrez 2035, 6230 with temperature adapter -15 ... +200°C (-5 ... +392°F)
- Kalrez 6375 -20 ... +130°C (-4 ... +266°F)
- Kalrez 6375 with temperature adapter -20 ... +200°C (-4 ... +392°F)

Vibration resistance mechanical vibrations with 4 g and 5 ... 100 Hz ⁴⁾

Data on rinsing air connection

Pressure	max. 6 bar (87 psi)
Thread	G $\frac{1}{8}$ A
Check valve (option, attached with Ex version)	
– Material	316Ti (stainless steel 1.4571)
– Seal	Viton
– for tube diameter	6 mm
– opening pressure	0.5 bar (7.3 psi)
– nominal pressure stage	PN 250

⁴⁾ Tested acc. to the regulations of German Lloyd, GL directive 2

Electromechanical data

Cable entry/plug⁵⁾

- single chamber housing
 - 1x cable entry M20x1.5 (cable- \emptyset 5 ... 9 mm), 1x blind stopper M20x1.5
 - or:
 - 1 x closing cap $\frac{1}{2}$ NPT, 1 x blind stopper $\frac{1}{2}$ NPT
 - or:
 - 1x plug (depending on the version), 1x blind stopper M20x1.5
- double chamber housing
 - 1 x cable entry M20x1.5 (cable- \emptyset 5 ... 9 mm), 1 x blind stopper M20x1.5, plug M12x1 for VEGADIS 61 (option)
 - or:
 - 1x closing cap $\frac{1}{2}$ NPT, 1x blind stopper $\frac{1}{2}$ NPT, plug M12x1 for VEGADIS 61 (option)
 - or:
 - 1x plug (depending on the version), 1x blind stopper M20x1.5, plug M12x1 for VEGADIS 61 (option)

Spring-loaded terminals

for wire cross sections up to 2.5 mm²

Indicating and adjustment module PLICSCOM

Power supply and data transmission	through sensor via gold-plated sliding contacts (I ² C bus)
Indication	LC display in dot matrix
Adjustment elements	4 keys
Protection	
– unassembled	IP 20
– mounted into the sensor without cover	IP 40

⁵⁾ depending on the version M12x1, acc. to DIN 43650, Harting, Amphenol-Tuchel, 7/8" FF

Materials

- housing ABS
- inspection window Polyester foil

Power supply

Supply voltage

- non-Ex instrument 15 ... 36 V DC (14 ... 36 V with VEGAMET)
- EEx ia instrument 15 ... 30 V DC (14 ... 30 V with VEGAMET)
- EExd ia instrument 20 ... 36 V DC

Permissible residual ripple

- < 100 Hz $U_{ss} < 1 V$
- 100 Hz ... 10 kHz $U_{ss} < 10 mV$

Load

see diagram

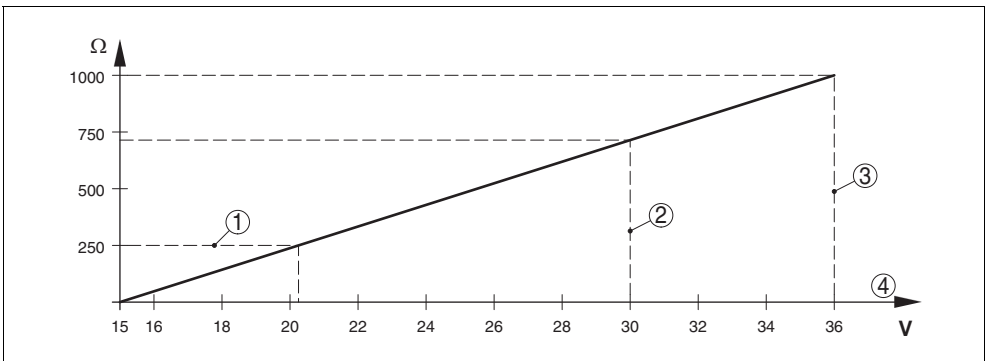

Fig. 32: Voltage diagram

- 1 HART load
- 2 Voltage limit EEx ia instrument
- 3 Voltage limit non-Ex instrument/Exd instrument
- 4 Supply voltage

Electrical protective measures

- Protection IP 66/IP 67
- Overvoltage category III
- Protection class II

Approvals^{6) 7)}

ATEX	ATEX II 1G, 1/2G, 2G EEx ia IIC T5; ATEX II 1/2G, 2G EEx d ia IIC T5; ATEX II 1/2D IP6X T
IEC	IEC EEx ia IIC T5

- ⁶⁾ Deviating data with Ex applications: see separate safety instructions
⁷⁾ depending on order specification

10.2 Dimensions

Housing

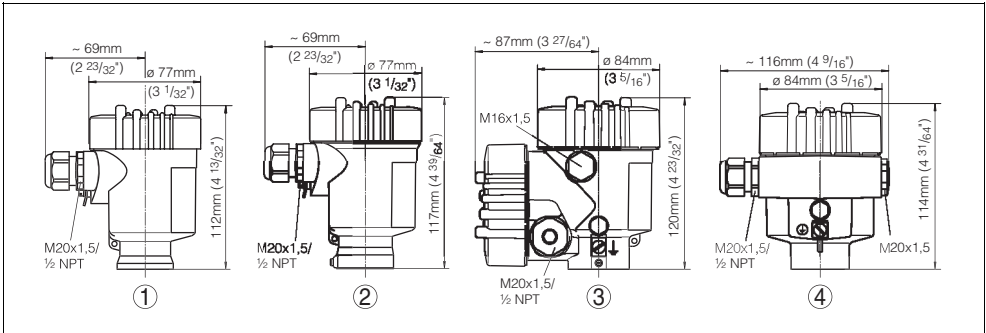

Fig. 33: Housing versions (with integrated PLICSCOM the height of the housing increases by 9 mm/0.35 in)

- 1 Plastic housing
- 2 Stainless steel housing
- 3 Aluminium double chamber housing
- 4 Aluminium housing

VEGAPULS 68 with horn antenna in threaded version

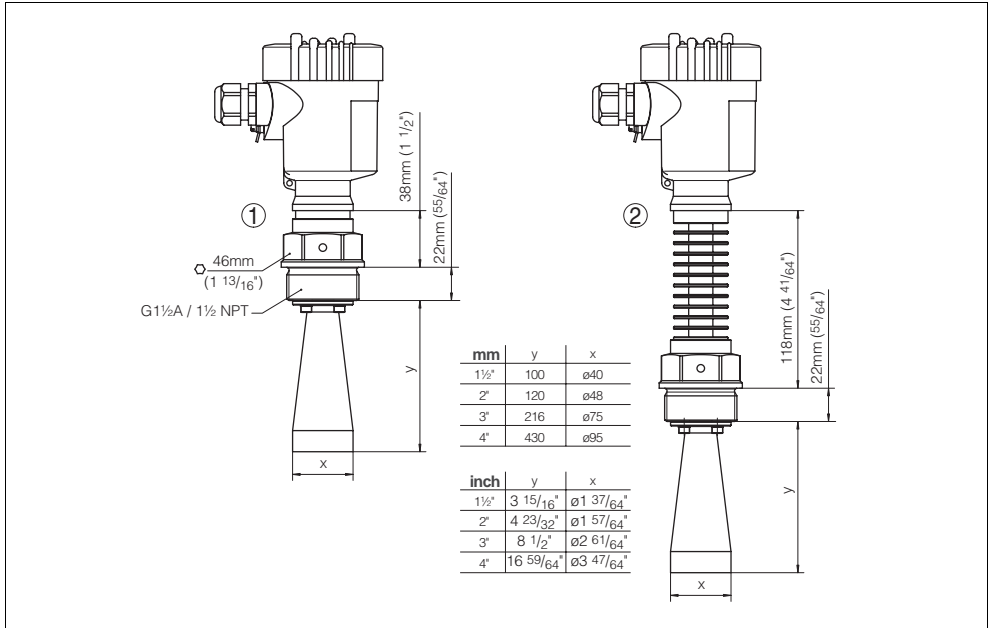

Fig. 34: VEGAPULS 68 with horn antenna in threaded version

1 Standard

2 with temperature adapter

VEGAPULS 68 with horn antenna in threaded version with purging air connection

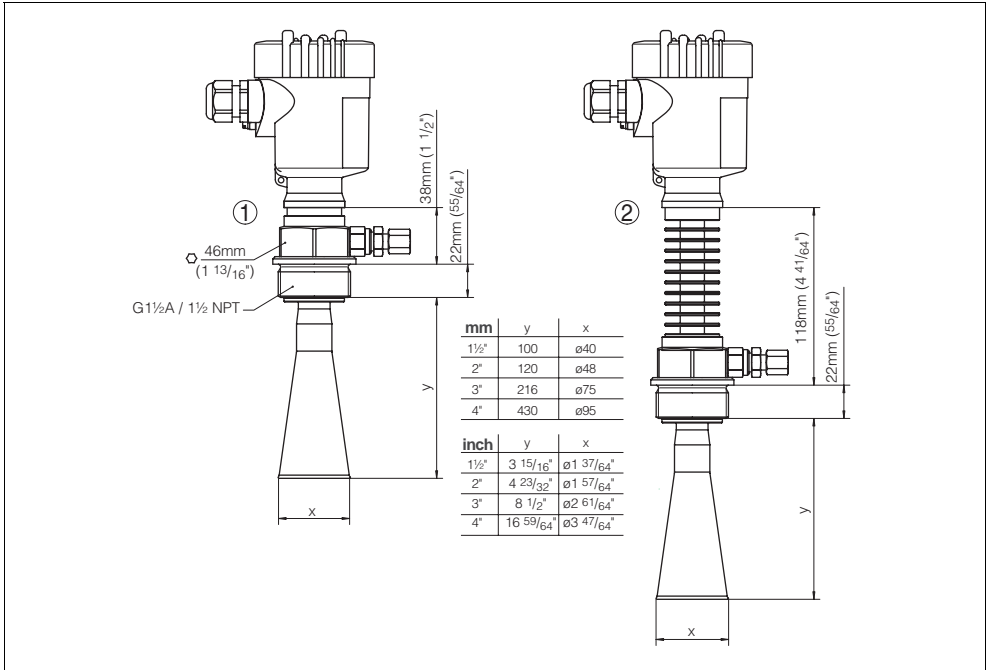

Fig. 35: VEGAPULS 68 with horn antenna in threaded version with purging air connection and reflux valve (option)

- 1 Standard
- 2 with temperature adapter

VEGAPULS 68 with horn antenna in threaded version with purging air connection and antenna extension

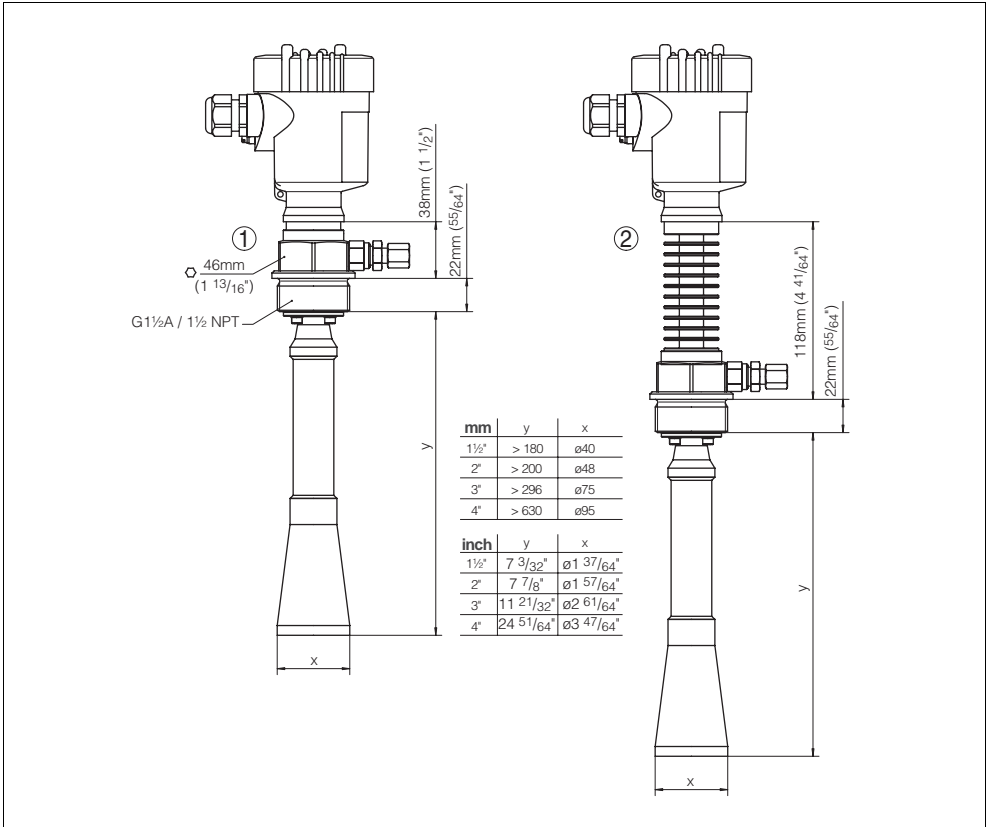

Fig. 36: VEGAPULS 68 with horn antenna in threaded version with purging air connection, antenna extension and reflux valve (option)

1 Standard

2 with temperature adapter

VEGAPULS 68 with horn antenna in flange version

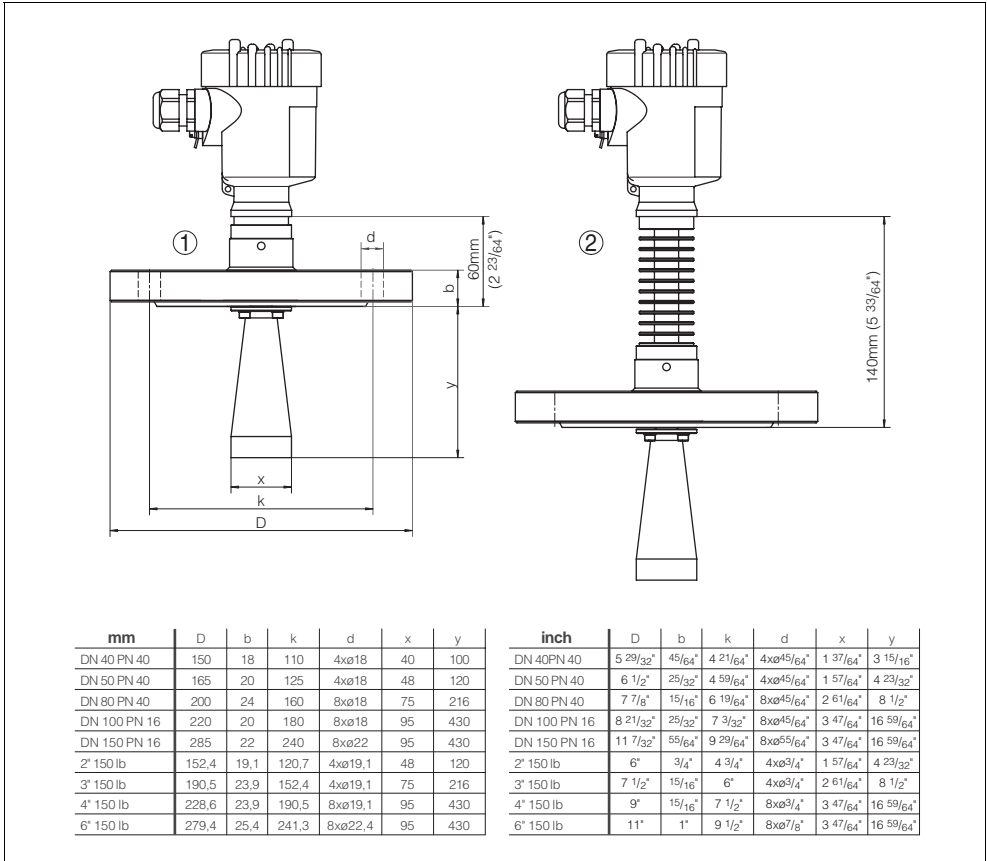

Fig. 37: VEGAPULS 68 with horn antenna in flange version

- 1 Standard
- 2 with temperature adapter

VEGAPULS 68 with horn antenna and swivelling holder

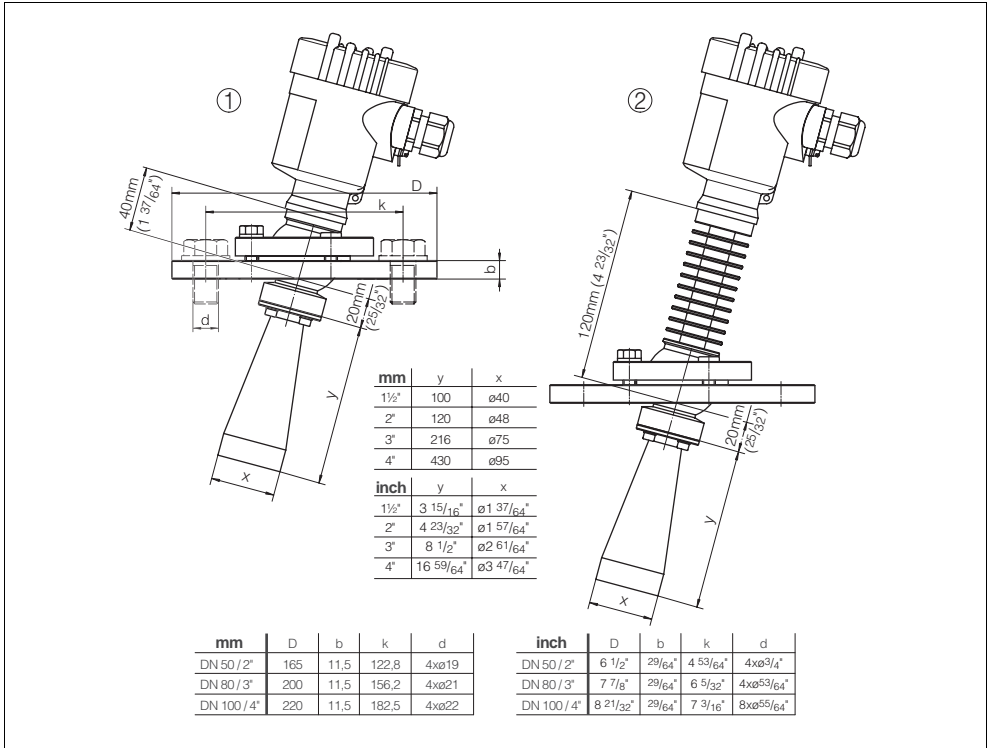

Fig. 38: VEGAPULS 68 with horn antenna and swivelling holder

- 1 Standard
- 2 with temperature adapter

VEGAPULS 68 with horn antenna, swivelling holder and purging air connection

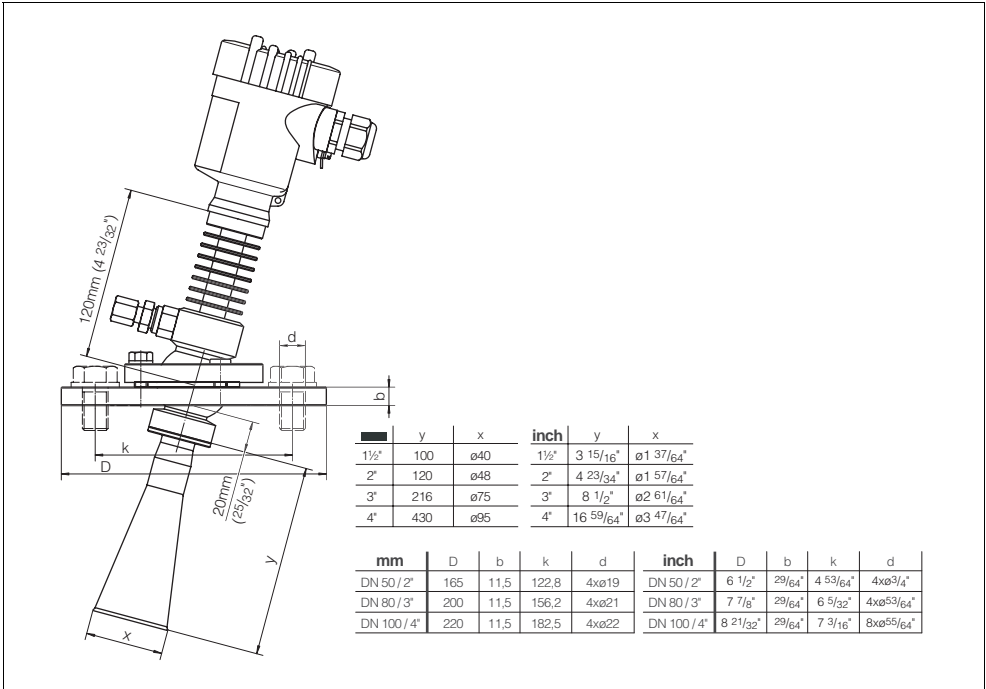

Fig. 39: VEGAPULS 68 with horn antenna, swivelling holder, purging air connection and reflux valve (option)

VEGAPULS 68 with horn antenna, swivelling holder, purging air connection and antenna extension

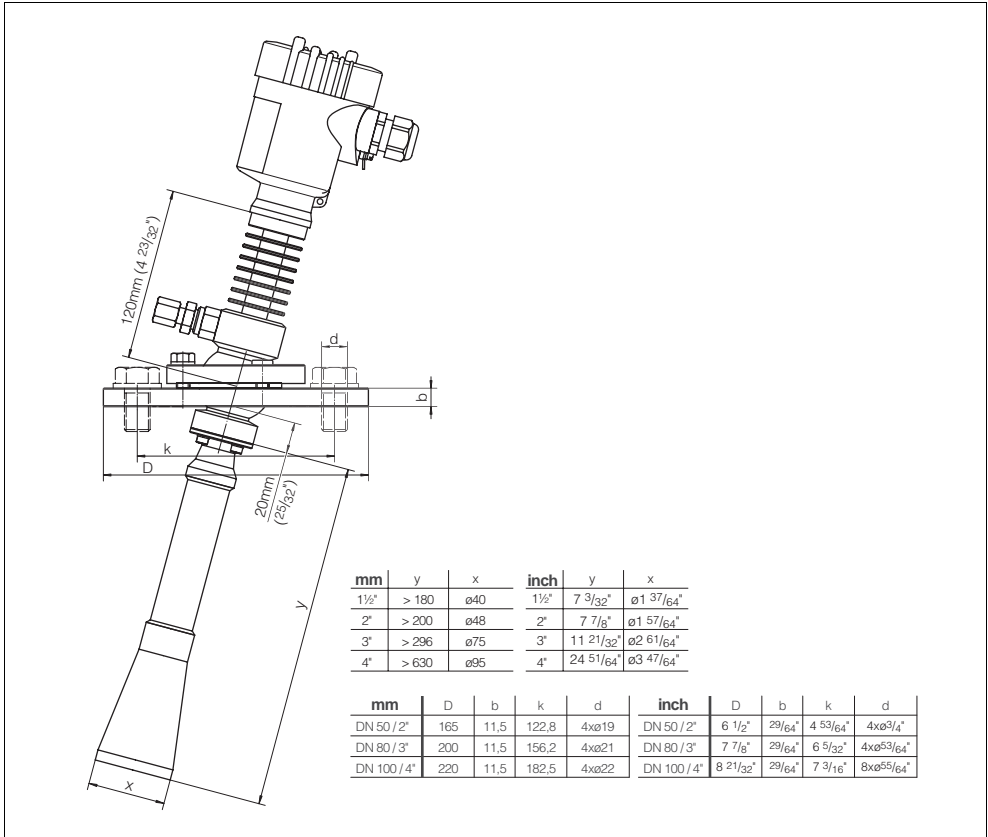

Fig. 40: VEGAPULS 68 with horn antenna, swivelling holder, purging air connection, antenna extension and reflux valve (option)

VEGAPULS 68 with parabolic antenna in threaded version

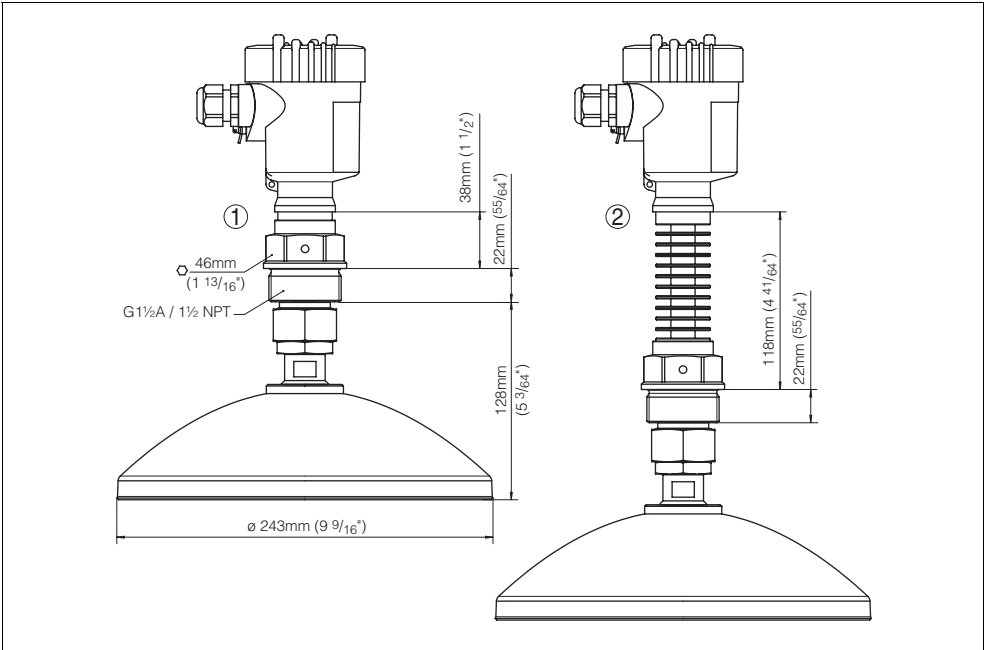

Fig. 41: VEGAPULS 68 with parabolic antenna in threaded version

1 Standard

2 with temperature adapter

VEGAPULS 68 with parabolic antenna in flange version

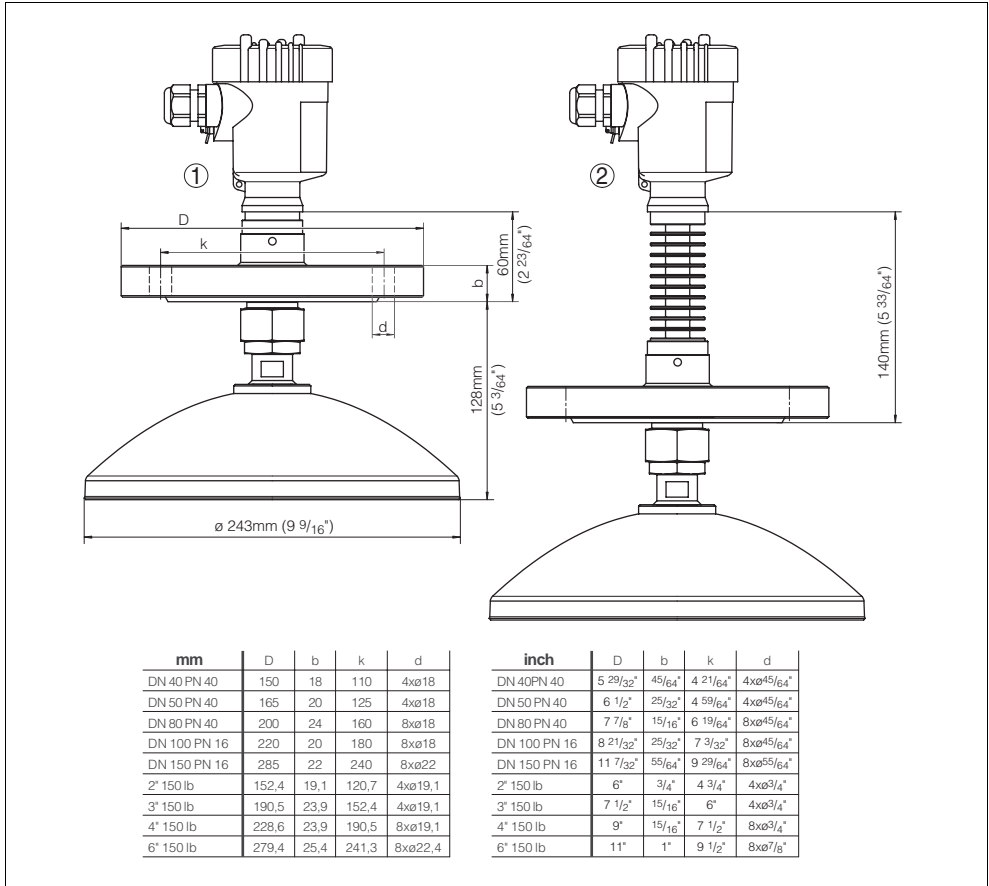

Fig. 42: VEGAPULS 68 with parabolic antenna in flange version

- 1 Standard
- 2 with temperature adapter

VEGAPULS 68 with parabolic antenna and swivelling holder

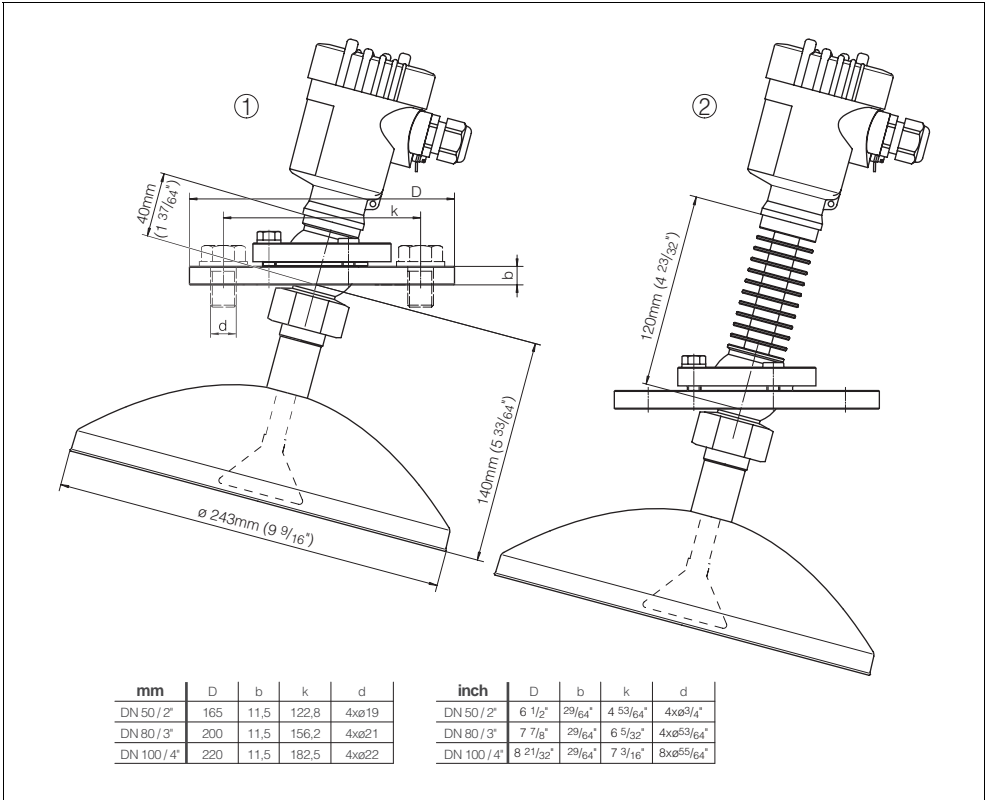

Fig. 43: VEGAPULS 68 with parabolic antenna and swivelling holder

1 Standard

2 with temperature adapter

10.3 CE declaration of conformity

CE

Konformitätserklärung

Declaration of conformity
Déclaration de conformité

VEGA^Δ

VEGA Grieshaber KG
Am Hohenstein 113
77761 Schiltach

erklärt in alleiniger Verantwortung, daß das Produkt / declare under
our sole responsibility that our product / déclare sous sa seule
responsabilité que le produit

VEGAPULS 68
4 ... 20 mA/HART

auf das sich diese Erklärung bezieht, mit den folgenden Normen
übereinstimmt / to which this declaration relates is in conformity
with the following standards / auquel se réfère cette déclaration
est conforme aux normes

EN 61326 : 1997 (Klasse B)
EN 61326 : 1997 / A1 : 1998
EN 61010 – 1 : 2001

gemäß den Bestimmungen der Richtlinien / following the provision
of Directives / conformément aux dispositions des Directives

73/23 EWG
89/336 EWG

Schiltach, 14.04.2004

Josef Fehrenbach
Entwicklungsleitung

Fig. 44: CE declaration of conformity



VEGA Grieshaber KG
Am Hohenstein 113
77761 Schiltach
Germany
Phone +49 7836 50-0
Fax +49 7836 50-201
E-mail: info@de.vega.com
www.vega.com



All statements concerning scope of delivery, application, practical use and operating conditions of the sensors and processing systems correspond to the information available at the time of printing.