

Operating Instructions

Radar sensor for continuous level
measurement of bulk solids

VEGAPULS 69

4 ... 20 mA/HART - two-wire



Document ID: 47247

VEGA

Contents

1	About this document	
1.1	Function	4
1.2	Target group	4
1.3	Symbols used.....	4
2	For your safety	
2.1	Authorised personnel	5
2.2	Appropriate use.....	5
2.3	Warning about incorrect use.....	5
2.4	General safety instructions	5
2.5	CE conformity.....	6
2.6	NAMUR recommendations	6
2.7	Radio license for Europe	6
2.8	Radio license for USA	7
2.9	Radio license for Canada	7
2.10	Environmental instructions	9
3	Product description	
3.1	Configuration.....	11
3.2	Principle of operation.....	12
3.3	Packaging, transport and storage.....	13
3.4	Accessories and replacement parts	13
4	Mounting	
4.1	General instructions	16
4.2	Mounting versions, plastic horn antenna	17
4.3	Mounting preparations, mounting strap	19
4.4	Mounting instructions	20
5	Connecting to power supply	
5.1	Preparing the connection	31
5.2	Connecting.....	32
5.3	Wiring plan, single chamber housing.....	34
5.4	Wiring plan, double chamber housing	34
5.5	Double chamber housing Ex d	36
5.6	Wiring plan, double chamber housing Ex d ia	37
5.7	Double chamber housing with DISADAPT	39
5.8	Wiring plan - version IP 66/IP 68, 1 bar.....	40
5.9	Switch-on phase.....	40
6	Set up with the display and adjustment module	
6.1	Insert display and adjustment module	41
6.2	Adjustment system	42
6.3	Measured value indication - Selection of national language	43
6.4	Parameter adjustment - Quick setup	44
6.5	Parameter adjustment - Extended adjustment.....	44
6.6	Saving the parameterisation data	58
7	Setup with PACTware	
7.1	Connect the PC	60
7.2	Parameter adjustment	61
7.3	Saving the parameterisation data	62

8	Set up with other systems	
8.1	DD adjustment programs	63
8.2	Field Communicator 375, 475	63
9	Diagnosis, asset management and service	
9.1	Maintenance	64
9.2	Measured value and event memory	64
9.3	Asset Management function.....	65
9.4	Rectify faults.....	68
9.5	Exchanging the electronics module.....	71
9.6	Software update	72
9.7	How to proceed if a repair is necessary.....	72
10	Dismount	
10.1	Dismounting steps.....	73
10.2	Disposal	73
11	Supplement	
11.1	Technical data	74
11.2	Radio astronomy stations.....	84
11.3	Dimensions	84
11.4	Industrial property rights.....	95
11.5	Trademark	95



Safety instructions for Ex areas

Take note of the Ex specific safety instructions for Ex applications. These instructions are attached as documents to each instrument with Ex approval and are part of the operating instructions manual.

Editing status: 2017-03-15

1 About this document

1.1 Function

This operating instructions manual provides all the information you need for mounting, connection and setup as well as important instructions for maintenance and fault rectification. Please read this information before putting the instrument into operation and keep this manual accessible in the immediate vicinity of the device.

1.2 Target group

This operating instructions manual is directed to trained specialist personnel. The contents of this manual should be made available to these personnel and put into practice by them.

1.3 Symbols used



Information, tip, note

This symbol indicates helpful additional information.



Caution: If this warning is ignored, faults or malfunctions can result.



Warning: If this warning is ignored, injury to persons and/or serious damage to the instrument can result.



Danger: If this warning is ignored, serious injury to persons and/or destruction of the instrument can result.



Ex applications

This symbol indicates special instructions for Ex applications.



List

The dot set in front indicates a list with no implied sequence.



Action

This arrow indicates a single action.



Sequence of actions

Numbers set in front indicate successive steps in a procedure.



Battery disposal

This symbol indicates special information about the disposal of batteries and accumulators.

2 For your safety

2.1 Authorised personnel

All operations described in this operating instructions manual must be carried out only by trained specialist personnel authorised by the plant operator.

During work on and with the device the required personal protective equipment must always be worn.

2.2 Appropriate use

VEGAPULS 69 is a sensor for continuous level measurement.

You can find detailed information about the area of application in chapter "*Product description*".

Operational reliability is ensured only if the instrument is properly used according to the specifications in the operating instructions manual as well as possible supplementary instructions.

2.3 Warning about incorrect use

Inappropriate or incorrect use of the instrument can give rise to application-specific hazards, e.g. vessel overflow or damage to system components through incorrect mounting or adjustment. Also the protective characteristics of the instrument can be influenced.

2.4 General safety instructions

This is a state-of-the-art instrument complying with all prevailing regulations and guidelines. The instrument must only be operated in a technically flawless and reliable condition. The operator is responsible for the trouble-free operation of the instrument.

During the entire duration of use, the user is obliged to determine the compliance of the necessary occupational safety measures with the current valid rules and regulations and also take note of new regulations.

The safety instructions in this operating instructions manual, the national installation standards as well as the valid safety regulations and accident prevention rules must be observed by the user.

For safety and warranty reasons, any invasive work on the device beyond that described in the operating instructions manual may be carried out only by personnel authorised by the manufacturer. Arbitrary conversions or modifications are explicitly forbidden.

The safety approval markings and safety tips on the device must also be observed.

Depending on the instrument version, the emitting frequencies are in the C, K or W band range. The low emission power is far below the internationally approved limit values. When used correctly, the device poses no danger to health.

2.5 CE conformity

The device fulfils the legal requirements of the applicable EU directives. By affixing the CE marking, we confirm the conformity of the instrument with these directives.

You can find the EU conformity declaration on our website under www.vega.com/downloads.

2.6 NAMUR recommendations

NAMUR is the automation technology user association in the process industry in Germany. The published NAMUR recommendations are accepted as the standard in field instrumentation.

The device fulfils the requirements of the following NAMUR recommendations:

- NE 43 – Signal level for malfunction information from measuring transducers
- NE 53 – Compatibility of field devices and display/adjustment components
- NE 107 – Self-monitoring and diagnosis of field devices

For further information see www.namur.de.

2.7 Radio license for Europe

The instrument was tested according to the latest issues of the harmonized standards:

- EN 302372 - Tank Level Probing Radar
- EN 302729 - Level Probing Radar

It is hence approved for use inside and outside closed vessels in countries of the EU.

Use is also approved in EFTA countries, provided these standards have been implemented.

For operation inside of closed vessels, the following conditions must be fulfilled:

- The instrument must be permanently mounted on a closed vessel made of metal, reinforced concrete, or comparable attenuating materials
- Flanges, process fittings and mounting accessories must ensure the microwave impermeability of the vessel and not let the radar signal escape to the outside
- If necessary, existing viewing windows in the vessel must be coated with a microwave impermeable material (e.g. electrically conductive coating)
- Manholes and flanges on the vessel must be closed and sealed to avoid penetration of the radar signal
- The instrument should be preferably mounted on top of the vessel with antenna orientation downward

For operation outside of closed vessels, the following conditions must be fulfilled:

- The instrument must be stationary mounted and the antenna directed vertically downward
- The instrument may only be used outside closed vessels in the version with G1½ or 1½ NPT thread with integrated horn antenna.
- The mounting location must be at least 4 km away from radio astronomy stations, unless special permission was granted by the responsible national approval authority
- When installed within 4 to 40 km of a radio astronomy station, the instrument must not be mounted higher than 15 m above the ground.

You can find a list of the respective radio astronomy stations in chapter "Supplement".

2.8 Radio license for USA

This approval is only valid for USA. Hence the following text is only available in the English language:

This device complies with Part 15 of the FCC Rules. Operation is subject to the following two conditions:

- This device may not cause interference, and
- This device must accept any interference, including interference that may cause undesired operation of the device

This device is approved for unrestricted use only inside closed, stationary vessels made of metal or concrete. From electronics index .-03 the use in containers made of reinforced fiberglass is also permitted.

For operation outside of closed vessels, the following conditions must be fulfilled:

- This device shall be installed and maintained to ensure a vertically downward orientation of the transmit antenna's main beam. Furthermore, the use of any mechanism that does not allow the main beam of the transmitter to be mounted vertically downward is prohibited.
- Operation of the instrument is only permitted with thread G1½ or 1½ NPT with integrated horn antenna.
- This device shall be installed only at fixed locations. The LPR device shall not operate while being moved or while inside a moving container.
- Hand-held applications are prohibited.
- Marketing to residential consumers is prohibited.

Changes or modifications not expressly approved by the manufacturer could void the user's authority to operate this equipment.

2.9 Radio license for Canada

This approval is only valid for Canada. Hence the following texts are only available in the English/French language:

This device complies with Industry Canada's license-exempt RSS standard(s). Operation is subject to the following conditions:

- This device may not cause interference, and
- This device must accept any interference, including interference that may cause undesired operation of the device

This device has been approved for both closed containers and open-air environments with the following limitations:

- Closed Containers: For installations utilizing a tilt during installation: This device is limited to installation in a completely enclosed container made of metal or concrete to prevent RF emissions, which can otherwise interfere with aeronautical navigation, the maximum approved tilt angle is 10°. From electronics index .-03 the use in containers made of reinforced fiberglass is also permitted.
- Open Air Environment: For operation outside of closed vessels, the following condition must be fulfilled: This device shall be installed and maintained to ensure a vertically downward orientation of the transmit antenna's main beam. Furthermore, the use of any mechanism that does not allow the main beam of the transmitter to be mounted vertically downward is prohibited.
- Operation of the instrument outside of closed vessels is only permitted with G1½ or 1½ NPT with integrated horn antenna.
- The installation of the LPR/TLPR device shall be done by trained installers, in strict compliance with the manufacturer's instructions.
- This device shall be installed only at fixed locations. The LPR device shall not operate while being moved or while inside a moving container.
- Hand-held applications are prohibited.
- Marketing to residential consumers is prohibited.
- The use of this device is on a "no-interference, no-protection" basis. That is, the user shall accept operations of high-powered radar in the same frequency band which may interfere with or damage this device.
- However, devices found to interfere with primary licensing operations will be required to be removed at the user's expense.
- The installer/user of this device shall ensure that it is at least 10 km from the Dominion Astrophysical Radio Observatory (DRAO) near Penticon, British Columbia. The coordinates of the DRAO are latitude 49°19'15" N and longitude 119°37'12"W. For devices not meeting this 10 km separation (e.g., those in the Okanagan Valley, British Columbia,) the installer/user must coordinate with, and obtain the written concurrence of, the Director of the DRAO before the equipment can be installed or operated. The Director of the DRAO may be contacted at 250-497-2300 (tel.) or 250-497-2355 (fax). (Alternatively, the Manager, Regulatory Standards, Industry Canada, may be contacted.)

Le présent appareil est conforme aux CNR d'Industrie Canada applicables aux appareils radio exempts de licence. L'exploitation est autorisée aux conditions suivantes :

- L'appareil ne doit pas produire de brouillage; et

- L'utilisateur de l'appareil doit accepter tout brouillage radioélectrique subi, même si le brouillage est susceptible d'en compromettre le fonctionnement.

Cet appareil est homologué pour une utilisation dans les cuves fermées et les environnements ouverts avec les restrictions suivantes :

- Cuves fermées: Pour les installations impliquant une inclinaison lors de l'installation : cet appareil ne doit être installé que dans une cuve totalement fermée en métal ou en béton, pour empêcher les émissions RF susceptibles d'interférer avec la navigation aéronautique. L'angle d'inclinaison maximum autorisé est de 10°. From electronics index .-03 the use in containers made of reinforced fiberglass is also permitted.
- Environnement ouvert : Pour l'utilisation hors des cuves fermées, la condition suivante doit être remplie : L'appareil doit être installé et entretenu de manière à garantir une orientation verticale vers le bas du faisceau principal de l'antenne émettrice. De plus, l'utilisation de tout mécanisme ne permettant pas l'orientation verticale vers le bas du faisceau principal de l'émetteur est interdite
- Il est uniquement autorisé d'utiliser la version d'appareil avec le filetage G1½ ou 1½ NPT en environnements ouvertes.
- L'installation d'un dispositif LPR ou TLPR doit être effectuée par des installateurs qualifiés, en pleine conformité avec les instructions du fabricant.
- Cet appareil ne doit être installé qu'à des emplacements fixes. L'appareil LPR ne doit pas être utilisé pendant qu'il est en train d'être déplacé ou se trouve dans un conteneur en mouvement.
- Les applications portables sont interdites.
- La vente à des particuliers est interdite
- Ce dispositif ne peut être exploité qu'en régime de non-brouillage et de non-protection, c'est-à-dire que l'utilisateur doit accepter que des radars de haute puissance de la même bande de fréquences puissent brouiller ce dispositif ou même l'endommager. D'autre part, les capteurs de niveau qui perturbent une exploitation autorisée par licence de fonctionnement principal doivent être enlevés aux frais de leur utilisateur.
- La personne qui installe/utilise ce capteur de niveau doit s'assurer qu'il se trouve à au moins 10 km de l'Observatoire fédéral de radioastrophysique (OFR) de Penticton en Colombie-Britannique. Les coordonnées de l'OFR sont : latitude N 49° 19' 15", longitude O 119° 37' 12". La personne qui installe/utilise un dispositif ne pouvant respecter cette distance de 10 km (p. ex. dans la vallée de l'Okanagan [Colombie-Britannique]) doit se concerter avec le directeur de l'OFR afin d'obtenir de sa part une autorisation écrite avant que l'équipement ne puisse être installé ou mis en marche. Le directeur de l'OFR peut être contacté au 250-497-2300 (tél.) ou au 250-497-2355 (fax). (Le Directeur des Normes réglementaires d'Industrie Canada peut également être contacté).

2.10 Environmental instructions

Protection of the environment is one of our most important duties. That is why we have introduced an environment management system

with the goal of continuously improving company environmental protection. The environment management system is certified according to DIN EN ISO 14001.

Please help us fulfil this obligation by observing the environmental instructions in this manual:

- Chapter "*Packaging, transport and storage*"
- Chapter "*Disposal*"

3 Product description

3.1 Configuration

Type label

The type label contains the most important data for identification and use of the instrument:

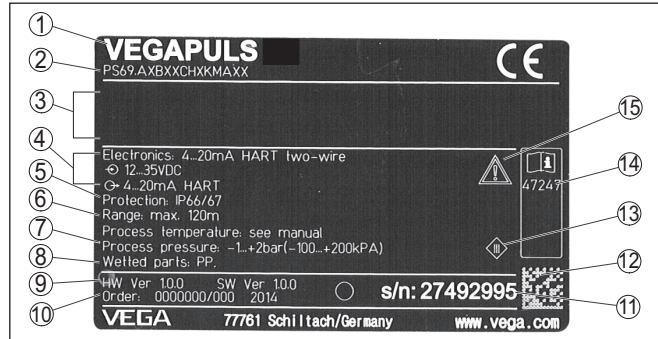

Fig. 1: Layout of the type label (example)

- 1 Instrument type
- 2 Product code
- 3 Approvals
- 4 Voltage supply and signal output, electronics
- 5 Protection rating
- 6 Measuring range
- 7 Process and ambient temperature, process pressure
- 8 Material, wetted parts
- 9 Hardware and software version
- 10 Order number
- 11 Serial number of the instrument
- 12 Data matrix code for smartphone app
- 13 Symbol of the device protection class
- 14 ID numbers, instrument documentation
- 15 Reminder to observe the instrument documentation
- 16 Notified authority for CE marking
- 17 Approval directive

Serial number - Instrument search

The type label contains the serial number of the instrument. With it you can find the following instrument data on our homepage:

- Product code (HTML)
- Delivery date (HTML)
- Order-specific instrument features (HTML)
- Operating instructions and quick setup guide at the time of shipment (PDF)
- Order-specific sensor data for an electronics exchange (XML)
- Test certificate (PDF) - optional

Go to "www.vega.com", "VEGA Tools" and "Instrument search". Enter the serial number.

Alternatively, you can access the data via your smartphone:

- Download the smartphone app "VEGA Tools" from the "Apple App Store" or the "Google Play Store"

- Scan the Data Matrix code on the type label of the instrument or
- Enter the serial number manually in the app

Scope of this operating instructions manual

This operating instructions manual applies to the following instrument versions:

- Hardware version from 1.0.0
- Software version from 1.1.0

Scope of delivery

The scope of delivery encompasses:

- Radar sensor
- Hexagon socket wrench (for instruments with swivel holder)
- Documentation
 - Quick setup guide VEGAPULS 69
 - Instructions for optional instrument features
 - Ex-specific "*Safety instructions*" (with Ex versions)
 - If necessary, further certificates
- DVD "*DTM Collection*", included therein
 - PACTware
 - DTM Collection
 - Instrument master files (GSD) for Profibus PA
 - FDT certificates



Information:

In this operating instructions manual, the optional instrument features are described. The respective scope of delivery results from the order specification.

3.2 Principle of operation

Application area

The VEGAPULS 69 is a radar sensor for continuous level measurement of bulk solids even under the most difficult process conditions and in very large measuring ranges.

It is ideal for use in high, slender silos with poorly reflecting bulk solids such as fly-ash, plastic granules or wood chips as well as internal installations that cause strong false echoes. This is made possible by its functional principle, a distance measurement through frequency shifting with an especially small beam angle.

The instrument is available with different antenna systems and accessories for virtually all applications and processes:

- Plastic horn antenna or metal-jacketed lens antenna
- Optional or integrated rinsing air connection
- Swivelling holder with seal against the process

Functional principle

The instrument emits a continuous radar signal through its antenna. This signal is frequency modulated in the form of a sawtooth wave. The emitted signal is reflected by the medium and received by the antenna as an echo.

The frequency of the received signal always deviates from the actual emitting frequency. The frequency difference is proportional to the distance and thus to the filling height. This difference is calculated

via special algorithms in the sensor electronics. The determined filling height is then converted into a corresponding output signal and outputted as the measured value.

3.3 Packaging, transport and storage

Packaging

Your instrument was protected by packaging during transport. Its capacity to handle normal loads during transport is assured by a test based on ISO 4180.

The packaging of standard instruments consists of environment-friendly, recyclable cardboard. For special versions, PE foam or PE foil is also used. Dispose of the packaging material via specialised recycling companies.

Transport

Transport must be carried out in due consideration of the notes on the transport packaging. Nonobservance of these instructions can cause damage to the device.

Transport inspection

The delivery must be checked for completeness and possible transit damage immediately at receipt. Ascertained transit damage or concealed defects must be appropriately dealt with.

Storage

Up to the time of installation, the packages must be left closed and stored according to the orientation and storage markings on the outside.

Unless otherwise indicated, the packages must be stored only under the following conditions:

- Not in the open
- Dry and dust free
- Not exposed to corrosive media
- Protected against solar radiation
- Avoiding mechanical shock and vibration

Storage and transport temperature

- Storage and transport temperature see chapter "*Supplement - Technical data - Ambient conditions*"
- Relative humidity 20 ... 85 %

3.4 Accessories and replacement parts

PLICSCOM

The display and adjustment module PLICSCOM is used for measured value indication, adjustment and diagnosis. It can be inserted into the sensor and removed at any time.

The integrated Bluetooth module (optional) enables wireless adjustment via standard adjustment devices:

- Smartphone/tablet (iOS or Android operating system)
- PC/notebook with Bluetooth USB adapter (Windows operating system)

You can find further information in the operating instructions "*Display and adjustment module PLICSCOM*" (Document-ID 27835).

VEGACONNECT

The interface adapter VEGACONNECT enables the connection of communication-capable instruments to the USB interface of a PC. For

parameter adjustment of these instruments, the adjustment software PACTware with VEGA-DTM is required.

You can find further information in the operating instructions "*Interface adapter VEGACONNECT*" (Document-ID 32628).

VEGADIS 81

The VEGADIS 81 is an external display and adjustment unit for VEGA plics® sensors.

For sensors with double chamber housing the interface adapter "*VEGADIS adapter*" is also required for VEGADIS 81.

You can find further information in the operating instructions "*VEGADIS 81*" (Document-ID 43814).

VEGADIS adapter

The VEGADIS adapter is an accessory part for sensors with double chamber housings. It enables the connection of VEGADIS 81 to the sensor housing via an M12 x 1 plug.

You can find further information in the supplementary instructions "*VEGADIS adapter*" (Document-ID 45250).

VEGADIS 82

VEGADIS 82 is suitable for measured value indication and adjustment of sensors with HART protocol. It is looped into the 4 ... 20 mA/HART signal cable.

You can find further information in the operating instructions "*VEGADIS 82 4 ... 20 mA/HART*" (Document-ID 45300).

PLICSMOBILE T61

PLICSMOBILE T61 is an external GSM/GPRS radio unit for transmission of measured values and for remote parameter adjustment of plics® sensors. Adjustment is carried out via PACTware/DTM and the integrated USB connection.

You can find further information in the supplementary instructions "*PLICSMOBILE T61*" (Document-ID 37700).

PLICSMOBILE

PLICSMOBILE is an internal GSM/GPRS radio unit for transmission of measured values and for remote configuration of plics® sensors. Adjustment is carried out via PACTware/DTM and the integrated USB connection.

You can find further information in the supplementary instructions "*PLICSMOBILE GSM/GPRS radio module*" (Document-ID 36849).

Protective cover

The protective cover protects the sensor housing against soiling and intense heat from solar radiation.

You will find additional information in the supplementary instructions manual "*Protective cover*" (Document-ID 34296).

Flanges

Screwed flanges are available in different versions according to the following standards: DIN 2501, EN 1092-1, BS 10, ASME B 16.5, JIS B 2210-1984, GOST 12821-80.

You can find additional information in the supplementary instructions manual "*Flanges according to DIN-EN-ASME-JIS*".

- Flanges with plastic horn antenna** For mounting the instrument with plastic horn antenna to a socket, two flange versions are available: the combi compression flange and the adapter flange
You can find additional information in chapter "*Mounting*" of this operating instruction.
- Mounting strap with plastic horn antenna** A mounting strap is available for mounting the instrument with plastic horn antenna to the wall or ceiling.
You can find additional information in chapter "*Mounting*" of this operating instruction.
- Electronics module** Electronics module "VEGAPULS series 60" is a replacement part for radar sensors of VEGAPULS series 60. A different version is available for each type of signal output.
You can find further information in the operating instructions "*Electronics module VEGAPULS series 60*" (Document-ID 36801).
- Supplementary electronics for double chamber housing** The supplementary electronics is a replacement part for 4 ... 20 mA/HART sensors with double chamber housing.
You can find further information in the operating instructions "*Supplementary electronics for 4 ... 20 mA/HART - two-wire*" (Document-ID 42764).

4 Mounting

4.1 General instructions

Protection against moisture

Protect your instrument against moisture ingress through the following measures:

- Use the recommended cable (see chapter "Connecting to power supply")
- Tighten the cable gland
- Loop the connection cable downward in front of the cable gland

This applies particularly to:

- Outdoor mounting
- Installations in areas where high humidity is expected (e.g. through cleaning processes)
- Installations on cooled or heated vessels

Suitability for the process conditions

Make sure that all parts of the instrument exposed to the process are suitable for the existing process conditions.

These are mainly:

- Active measuring component
- Process fitting
- Process seal

Process conditions in particular are:

- Process pressure
- Process temperature
- Chemical properties of the medium
- Abrasion and mechanical influences

You can find detailed information on the process conditions in chapter "Technical data" as well as on the type label.

Cable glands

Metric threads

In the case of instrument housings with metric thread, the cable glands are screwed in at the factory. They are sealed with plastic plugs as transport protection.

You have to remove these plugs before electrical connection.

NPT thread

In the case of instrument housings with self-sealing NPT threads, it is not possible to have the cable entries screwed in at the factory. The free openings for the cable glands are therefore covered with red dust protection caps as transport protection. The dust protection caps do not provide sufficient protection against moisture.

Prior to setup you have to replace these protective caps with approved cable glands or close the openings with suitable blind plugs.

Radio license for USA/Canada

The mounting position and orientation of the sensor must take into account the limitations in chapter "For your safety", "Radio approval for USA" "Radio approval for Canada" of this operating instructions.

4.2 Mounting versions, plastic horn antenna

Mounting strap

The optional mounting strap allows simple mounting of the instrument on a wall, ceiling or boom. Especially in the case of open vessels, this is a simple and effective way to align the sensor to the surface of the bulk solid material.

The following versions are available:

- Length 300 mm
- Length 170 mm

Mounting strap - Ceiling mounting

The instrument is normally mounted vertically with a bracket on the ceiling.

This allows swivelling the sensor up to 180° for optimal orientation and rotating for optimal connection.

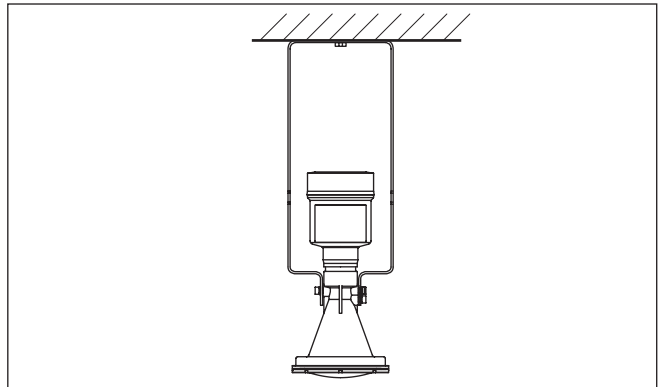

Fig. 2: Ceiling mounting via the mounting strap with length 300 mm

Mounting strap - Wall mounting

As an alternative the strap mounting is carried out horizontally or obliquely.

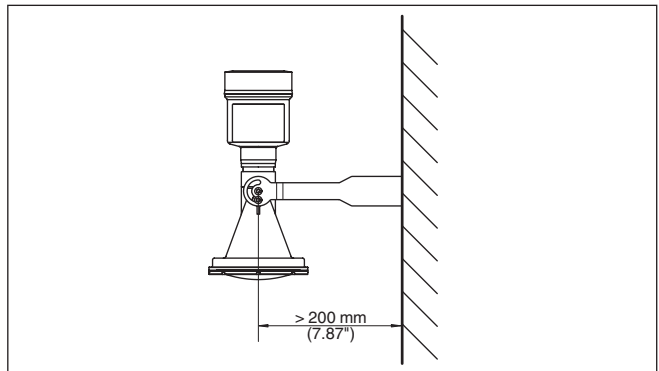

Fig. 3: Wall mounting horizontally via the mounting strap with length 170 mm

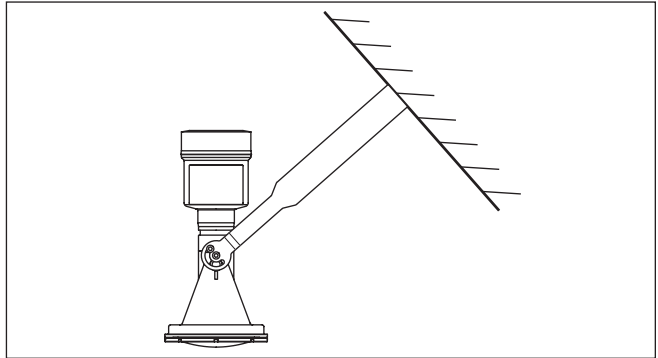

Fig. 4: Wall mounting with inclined wall via the mounting strap with length 300 mm

Flange

Two versions are available for mounting the instrument on a socket:

- Combi compression flange
- Adapter flange

Combi compression flange

The combi compression flange is suitable for different vessel flanges DN 80, ASME 3" and JIS 80. It comes not sealed against the radar sensor and can thus only be used unpressurized. It can be retrofitted on instruments with single chamber housing, retrofitting to a double chamber housing is not possible.

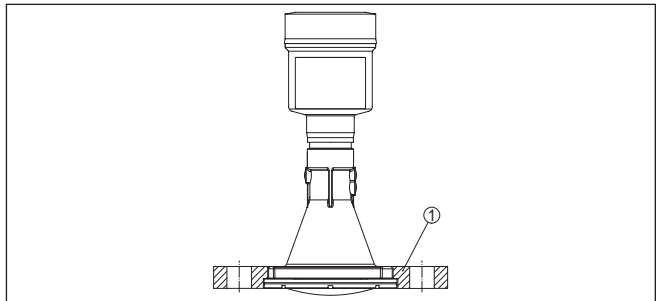

Fig. 5: Combi compression flange

1 Combi compression flange

Adapter flange

The adapter flange is available from DN 100, ASME 4" and JIS 100. It is permanently connected with the radar sensor and sealed.

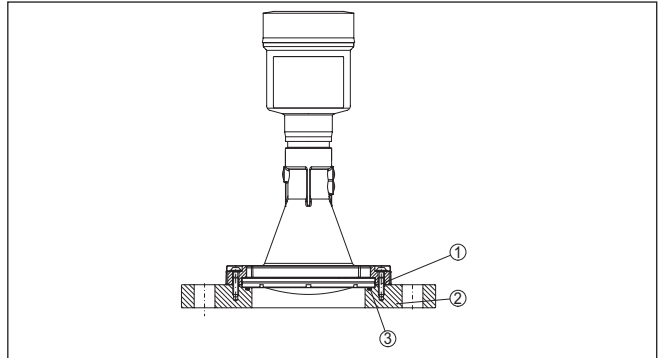

Fig. 6: Adapter flange

- 1 Connection screw
- 2 Adapter flange
- 3 Process seal

4.3 Mounting preparations, mounting strap

The mounting strap is supplied unassembled (optionally) and must be screwed to the sensor before setup with three hexagon socket screws M5 x 10 and spring washers. Max. torque, see chapter "Technical data". Required tools: Allen wrench size 4.

There are two different variants of screwing the strap to the sensor, see following illustration:

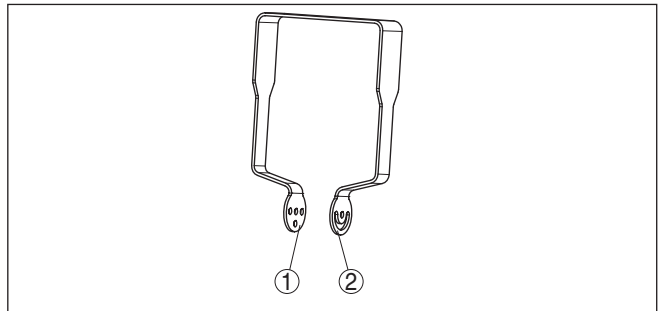

Fig. 7: Mounting strap for screwing to the sensor

- 1 For angle of inclination in steps
- 2 For angle of inclination, infinitely variable

Depending on the selected variant, the sensor can be rotated in the strap:

- Single chamber housing
 - Angle of inclination in three steps 0°, 90° and 180°
 - Angle of inclination 180°, infinitely variable
- Double chamber housing
 - Angle of inclination in two steps 0° and 90°
 - Angle of inclination 90°, infinitely variable

4.4 Mounting instructions

Polarisation

Radars sensors for level measurement emit electromagnetic waves. The polarization is the direction of the electrical component of these waves.

The polarization direction is marked by a nose on the housing, see following drawing:

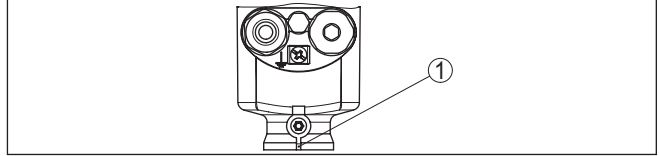

Fig. 8: Position of the polarisation

1 Nose for marking the direction of polarisation



Note:

When the housing is rotated, the direction of polarization changes and hence the influence of the false echo on the measured value. Please keep this in mind when mounting or making changes later.

Installation position

Mount the sensor at least 200 mm (7.874 in) away from the vessel wall.

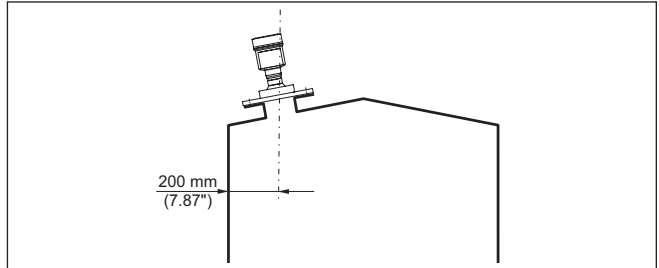

Fig. 9: Mounting the radar sensor on the vessel top

If you cannot maintain this distance, you should carry out a false signal suppression during setup. This applies particularly if buildup on the vessel wall is expected. In such cases, we recommend repeating the false signal suppression at a later date with existing buildup.

Inflowing medium

The instrument should not be mounted too close to the inflowing medium, as the radar signal could be disrupted.

Silo with filling from top

The optimal mounting position is opposite the filling aperture. To avoid heavy soiling, the distance to any filter or dust exhauster should be as large as possible.

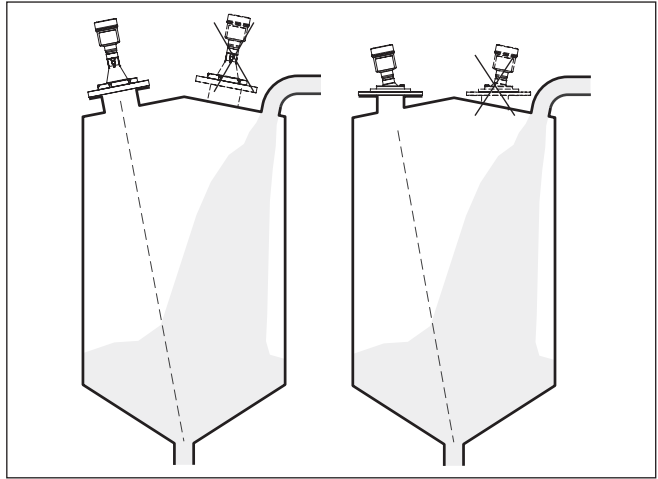

Fig. 10: Mounting of the radar sensor with inflowing medium

Silo with lateral filling

In bulk solids silos with lateral pneumatic filling the instrument should not be mounted above the filling stream, as the radar signal will be disrupted. The optimal mounting position is to the side of the filling aperture. To avoid heavy soiling, the distance to any filter or dust exhauster should be as large as possible.

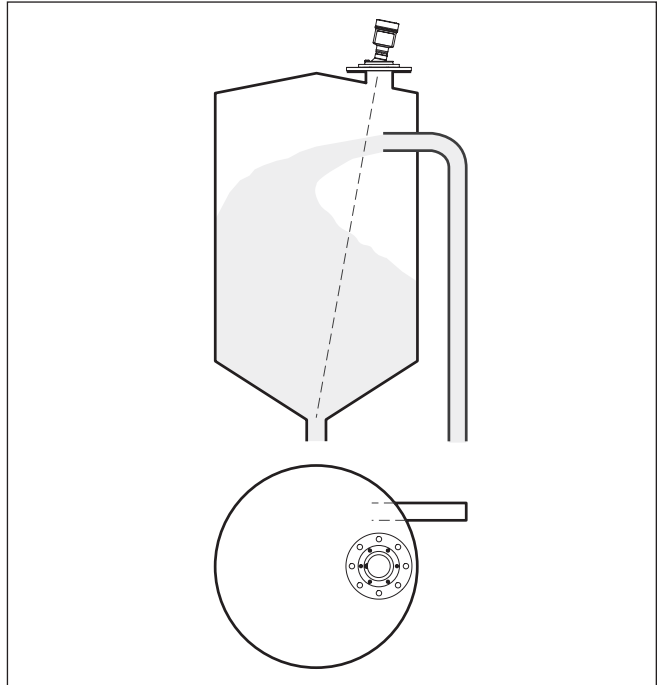

Fig. 11: Mounting of the radar sensor with inflowing medium

Type of socket



Information:

The mounting socket should be as short as possible and its end rounded. This reduces false echoes from the vessel mounting socket.

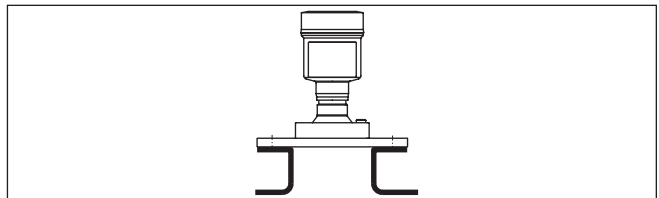

Fig. 12: Recommended socket mounting

If the medium has good reflective properties, you can also mount the VEGAPULS 69 on longer sockets. Approximate socket heights are shown in the following illustration.



Information:

When mounting on longer sockets, we recommend carrying out a false signal suppression (see chapter "Parameter adjustment").

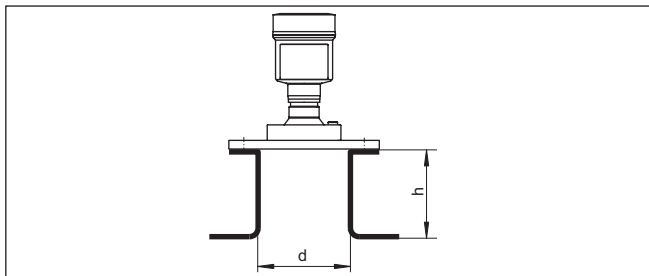

The below charts specify the max. pipe socket length h depending on the diameter d .

Socket diameter d	Socket length h
80 mm	≤ 200 mm
100 mm	≤ 300 mm
150 mm	≤ 500 mm

Socket diameter d	Socket length h
3"	≤ 7.87 in
4"	≤ 11.8 in
6"	≤ 19.7 in

Orientation

In order to measure as much of the vessel volume as possible, the sensor should be aligned so that the radar signal reaches the lowest level in the vessel. In a cylindrical silo with conical outlet, the sensor is mounted anywhere from one third to one half of the vessel radius from the outside wall (see following drawing).

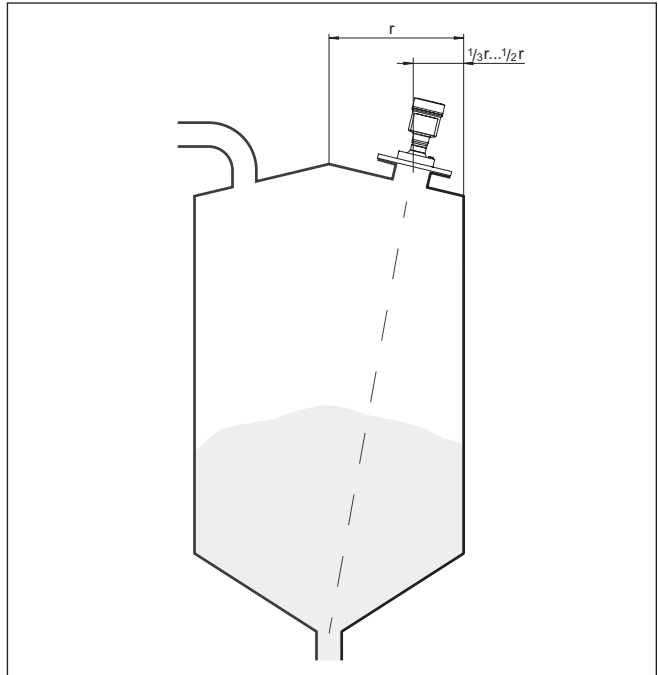

Fig. 14: Mounting position and orientation

With the help of an optional swivelling holder, the sensor can be easily aligned to the vessel centre. The necessary angle of inclination depends on the vessel dimensions. It can be easily checked with a suitable bubble tube or mechanic's level on the sensor.

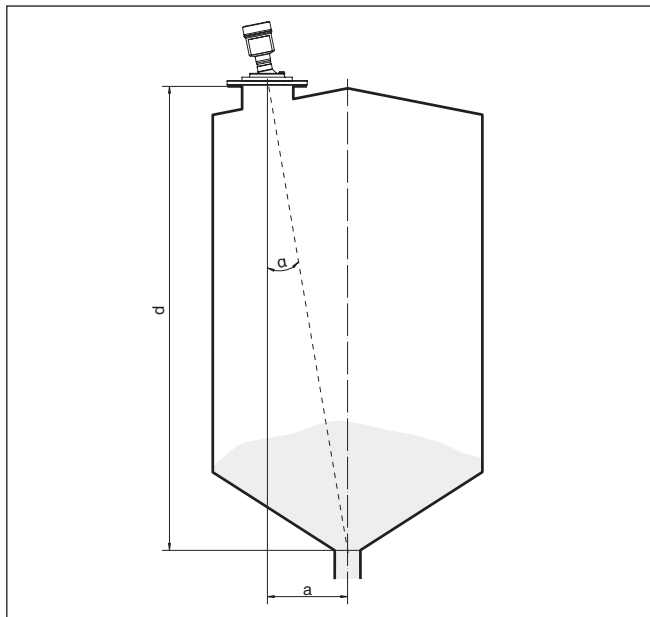

Fig. 15: Proposal for installation after orientation VEGAPULS 69

The following table shows the necessary angle of inclination. It depends on the measuring distance and the distance "a" between vessel centre and installation position.

Distance d (m)	2°	4°	6°	8°	10°
2	0.1	0.1	0.2	0.3	0.4
4	0.1	0.3	0.4	0.6	0.7
6	0.2	0.4	0.6	0.8	1.1
8	0.3	0.6	0.8	1.1	1.4
10	0.3	0.7	1.1	1.4	1.8
15	0.5	1	1.6	2.1	2.6
20	0.7	1.4	2.1	2.8	3.5
25	0.9	1.7	2.6	3.5	4.4
30	1	2.1	3.2	4.2	5.3
35	1.2	2.4	3.7	4.9	6.2
40	1.4	2.8	4.2	5.6	7.1
45	1.6	3.1	4.7	6.3	7.9
50	1.7	3.5	5.3	7	8.8
60	2.1	4.2	6.3	8.4	10.5
70	2.4	4.9	7.3	9.7	12.2

Distance d (m)	2°	4°	6°	8°	10°
80	2.8	5.6	8.4	11.1	13.9
90	3.1	6.3	9.4	12.5	15.6
100	3.5	7	10.5	13.9	17.4
110	3.8	7.7	11.5	15.3	19.1
120	4.2	8.4	12.5	16.7	20.8

Example:

In a vessel 20 m high, the installation position of the sensor is 1.4 m from the vessel centre.

The necessary angle of inclination of 4° can be read out from this table.

Proceed as follows to adjust the angle of inclination with the swivelling holder:

1. Loosen the terminal screws of the swivel holder by one turn. Use a hexagon socket wrench, size 5.

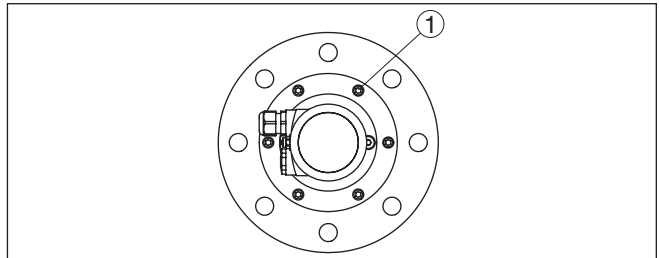

Fig. 16: VEGAPULS 69 with swivelling holder

1 Terminal screws (6 pcs.)

2. Align the sensor, check angle of inclination

**Information:**

The max. angle of inclination of the swivelling holder is approx. 10°

3. Re-tighten the terminal screws, max. torque see chapter "Technical data".

Vessel installations

The mounting location of the radar sensor should be a place where no other equipment or fixtures cross the path of the radar signals.

Vessel installations, such as e.g. ladders, limit switches, heating spirals, struts, etc., can cause false echoes and impair the useful echo. Make sure when planning your measuring point that the radar sensor has a "clear view" to the measured product.

In case of existing vessel installations, a false signal suppression should be carried out during setup.

If large vessel installations such as struts or supports cause false echoes, these can be attenuated through supplementary measures.

Small, inclined sheet metal baffles above the installations scatter the radar signals and prevent direct interfering reflections.

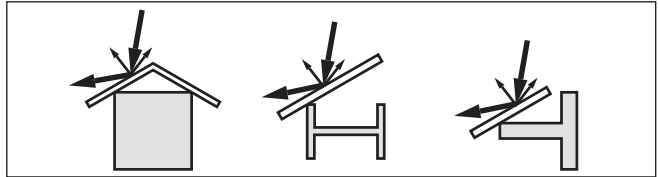

Fig. 17: Cover flat, large-area profiles with deflectors

Material heaps

Large material heaps are best measured with several instruments, which can be mounted on e.g. traverse cranes. For this type of application it is advantageous to orient the sensor perpendicular to the bulk solid surface.

The sensors do not influence each other.



Information:

Keep in mind that for these applications, the sensors are designed for relatively slow level changes. If the sensor is used on a movable boom, the max. measuring rate must be observed (see chapter "Technical data").

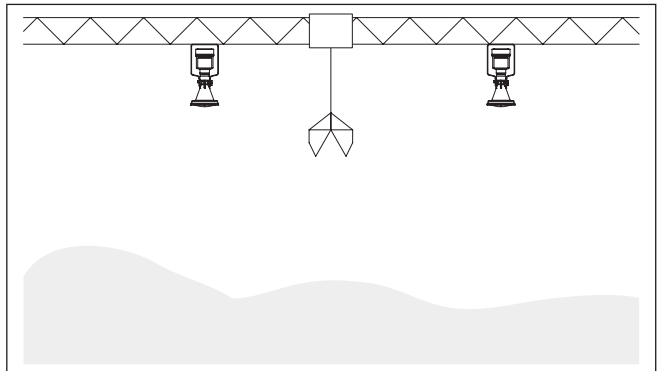

Fig. 18: Radar sensors on traverse crane

Mounting in the vessel insulation

Instruments for a temperature range up to 200° C have a spacer between process fitting and electronics housing. This spacer is used to thermally decouple the electronics from the high process temperatures.



Information:

The spacer may only be incorporated up to a maximum of 50 mm into the vessel insulation. Only then is a reliable temperature decoupling guaranteed.

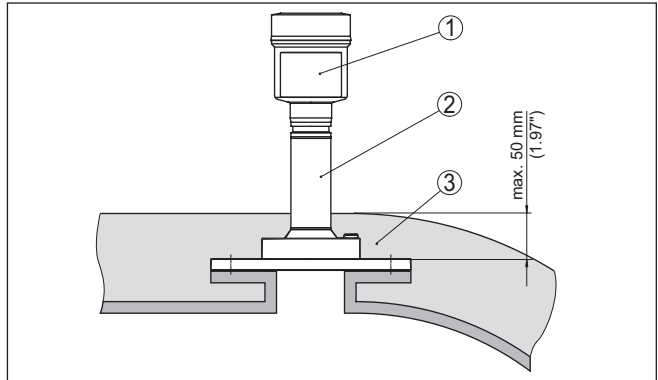

Fig. 19: Mounting the instrument on insulated vessels.

- 1 Electronics housing
- 2 Spacer
- 3 Vessel insulation

Mounting in multiple chamber silo

The walls of multiple-chamber silos are often made of profile material, e.g. profile sheeting, to ensure the required stability. If the radar sensor is mounted very close to a heavily structured vessel wall, substantial interfering reflections can be generated. Thus the sensor should be mounted at the largest possible distance from the separating wall.

The best mounting location is on the outer wall of the silo, with the sensor pointing towards the discharge opening in the silo centre. This can be accomplished, for example, with the mounting strap.

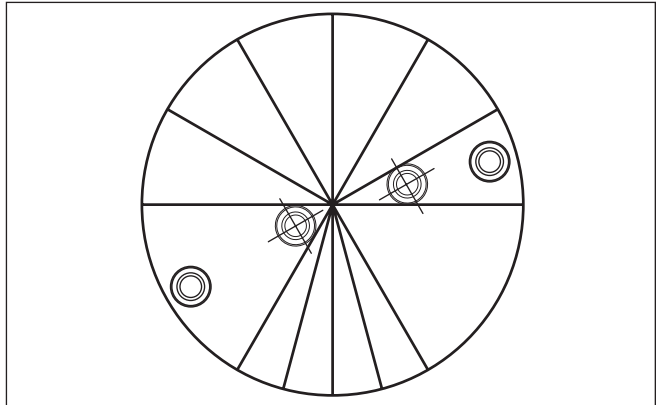

Fig. 20: Installation and orientation in multiple chamber silos

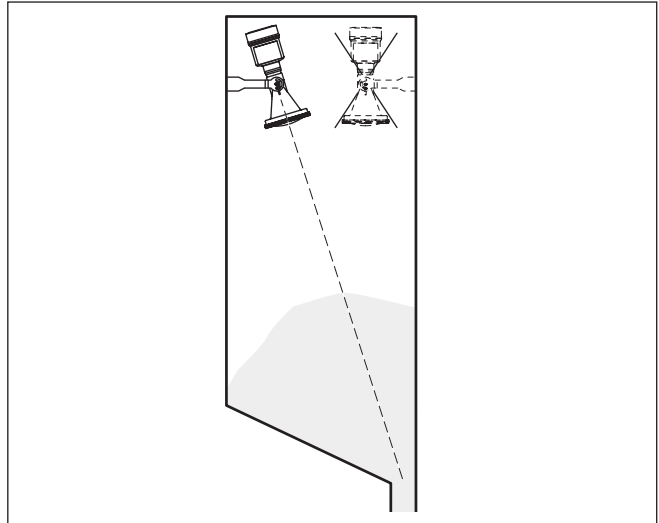

Fig. 21: Installation and orientation in multiple chamber silos

Dust deposits - Rinsing air connection

To avoid heavy buildup and dust on the antenna, the sensor should not be mounted close to the dust exhauster inside the vessel.

To protect the sensor against buildup, particularly in case of strong condensation, air rinsing is recommended.

Metal-jacketed lens antenna

The VEGAPULS 69 with metal-jacketed lens antenna is equipped with a rinsing air connection as a standard feature, see following graphics.

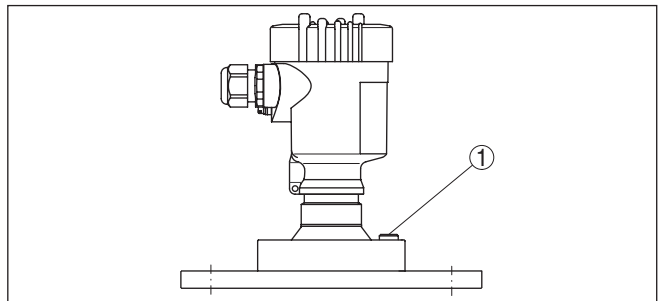

Fig. 22: Rinsing air connection on metal-jacketed lens antenna

Plastic horn antenna

The VEGAPULS 69 with plastic horn antenna is optionally available with a rinsing air connection. The mechanical configuration differs according to the flange version, see following graphics.

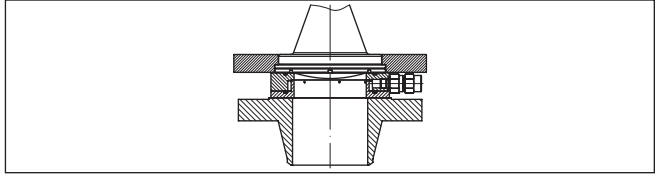

Fig. 23: Rinsing air connection with compression flange

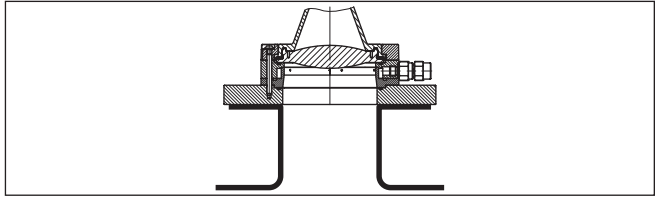

Fig. 24: Rinsing air connection with adapter flange

You can find details on the rinsing air connection in chapter "Technical data".

5 Connecting to power supply

5.1 Preparing the connection

Safety instructions

Always keep in mind the following safety instructions:



Warning:

Connect only in the complete absence of line voltage.

- The electrical connection must only be carried out by trained personnel authorised by the plant operator.
- If overvoltage surges are expected, overvoltage arresters should be installed.

Voltage supply

Power supply and current signal are carried on the same two-wire cable. The operating voltage can differ depending on the instrument version.

The data for power supply are specified in chapter "*Technical data*".

Provide a reliable separation between the supply circuit and the mains circuits according to DIN EN 61140 VDE 0140-1.

Keep in mind the following additional factors that influence the operating voltage:

- Lower output voltage of the power supply unit under nominal load (e.g. with a sensor current of 20.5 mA or 22 mA in case of fault)
- Influence of additional instruments in the circuit (see load values in chapter "*Technical data*")

Connection cable

The instrument is connected with standard two-wire cable without screen. If electromagnetic interference is expected which is above the test values of EN 61326-1 for industrial areas, screened cable should be used.

Use cable with round cross section for instruments with housing and cable gland. To ensure the seal effect of the cable gland (IP protection rating), find out which cable outer diameter the cable gland is suitable for.

Use a cable gland fitting the cable diameter.

Screened cable generally necessary in HART multidrop mode.

Cable glands

Metric threads

In the case of instrument housings with metric thread, the cable glands are screwed in at the factory. They are sealed with plastic plugs as transport protection.

You have to remove these plugs before electrical connection.

NPT thread

In the case of instrument housings with self-sealing NPT threads, it is not possible to have the cable entries screwed in at the factory. The free openings for the cable glands are therefore covered with red dust protection caps as transport protection.

Prior to setup you have to replace these protective caps with approved cable glands or close the openings with suitable blind plugs.

On plastic housings, the NPT cable gland or the Conduit steel tube must be screwed into the threaded insert without grease.

Max. torque for all housings, see chapter "*Technical data*".

Cable screening and grounding

If screened cable is required, the cable screen must be connected on both ends to ground potential. In the sensor, the screen is connected directly to the internal ground terminal. The ground terminal on the outside of the housing must be connected to the ground potential (low impedance).



In Ex systems, the grounding is carried out according to the installation regulations.

In electroplating plants as well as plants for cathodic corrosion protection it must be taken into account that significant potential differences exist. This can lead to unacceptably high currents in the cable screen if it is grounded at both ends.



Information:

The metallic parts of the instrument (process fitting, sensor, concentric tube, etc.) are connected with the internal and external ground terminal on the housing. This connection exists either directly via the conductive metallic parts or, in case of instruments with external electronics, via the screen of the special connection cable.

You can find specifications on the potential connections inside the instrument in chapter "*Technical data*".

5.2 Connecting

Connection technology

The voltage supply and signal output are connected via the spring-loaded terminals in the housing.

Connection to the display and adjustment module or to the interface adapter is carried out via contact pins in the housing.



Information:

The terminal block is pluggable and can be removed from the electronics. To do this, lift the terminal block with a small screwdriver and pull it out. When reinserting the terminal block, you should hear it snap in.

Connection procedure

Proceed as follows:

1. Unscrew the housing lid
2. If a display and adjustment module is installed, remove it by turning it slightly to the left.
3. Loosen compression nut of the cable gland and remove blind plug
4. Remove approx. 10 cm (4 in) of the cable mantle, strip approx. 1 cm (0.4 in) of insulation from the ends of the individual wires
5. Insert the cable into the sensor through the cable entry



Fig. 25: Connection steps 5 and 6 - Single chamber housing



Fig. 26: Connection steps 5 and 6 - Double chamber housing

6. Insert the wire ends into the terminals according to the wiring plan



Information:

Solid cores as well as flexible cores with wire end sleeves are inserted directly into the terminal openings. In case of flexible cores without end sleeves, press the terminal from above with a small screwdriver, the terminal opening is then free. When the screwdriver is released, the terminal closes again.

You can find further information on the max. wire cross-section under "Technical data - Electromechanical data"

7. Check the hold of the wires in the terminals by lightly pulling on them
8. Connect the screen to the internal ground terminal, connect the external ground terminal to potential equalisation

9. Tighten the compression nut of the cable entry gland. The seal ring must completely encircle the cable
 10. Reinsert the display and adjustment module, if one was installed
 11. Screw the housing lid back on
- The electrical connection is finished.

5.3 Wiring plan, single chamber housing



The following illustration applies to the non-Ex as well as to the Ex-ia version.

Electronics and terminal compartment

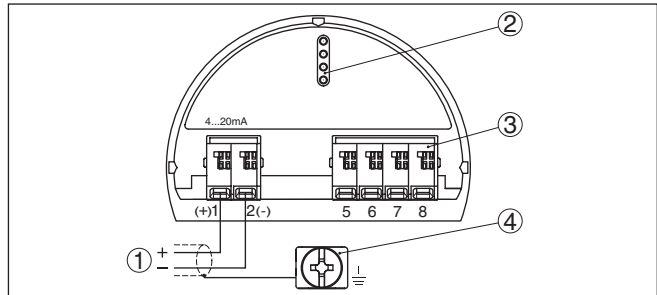

Fig. 27: Electronics and terminal compartment - single chamber housing

- 1 Voltage supply, signal output
- 2 For display and adjustment module or interface adapter
- 3 For external display and adjustment unit
- 4 Ground terminal for connection of the cable screen

5.4 Wiring plan, double chamber housing



The following illustrations apply to the non-Ex as well as to the Ex-ia version.

Electronics compartment

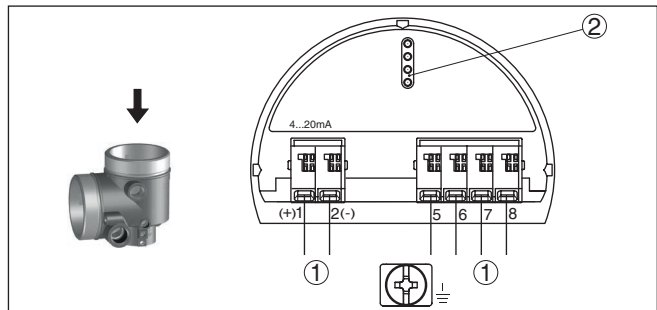

Fig. 28: Electronics compartment - double chamber housing

- 1 Internal connection to the terminal compartment
- 2 For display and adjustment module or interface adapter

Terminal compartment

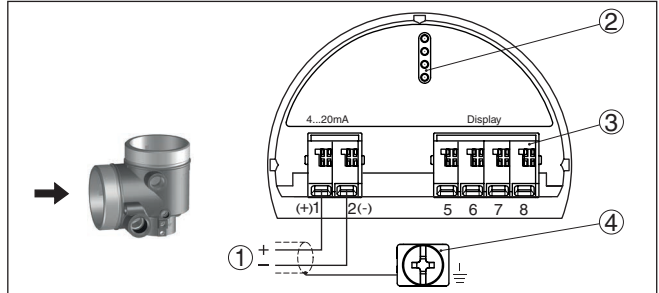

Fig. 29: Terminal compartment - double chamber housing

- 1 Voltage supply, signal output
- 2 For display and adjustment module or interface adapter
- 3 For external display and adjustment unit
- 4 Ground terminal for connection of the cable screen

Supplementary electronics - Additional current output

To make a second measured value available for use, you can use the supplementary electronics "Additional current output".

Both current outputs are passive and need a power supply.

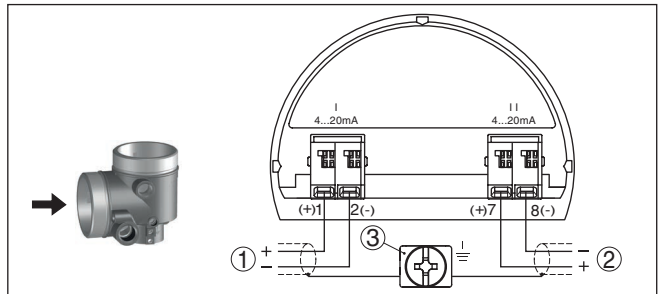

Fig. 30: Terminal compartment, double chamber housing, supplementary electronics "Additional current output"

- 1 First current output (I) - Voltage supply and signal output, sensor (HART)
- 2 Additional current output (II) - Voltage supply and signal output (without HART)
- 3 Ground terminal for connection of the cable screen

Terminal compartment - Radio module PLICSMOBILE

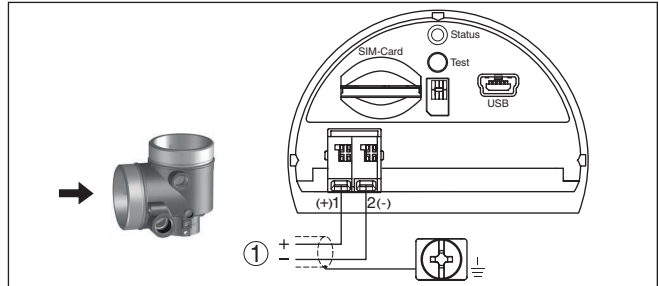

Fig. 31: Terminal compartment - Radio module PLICSMOBILE

1 Voltage supply

You can find detailed information on connection in the supplementary instructions "PLICSMOBILE GSM/GPRS radio module".

5.5 Double chamber housing Ex d

Electronics compartment

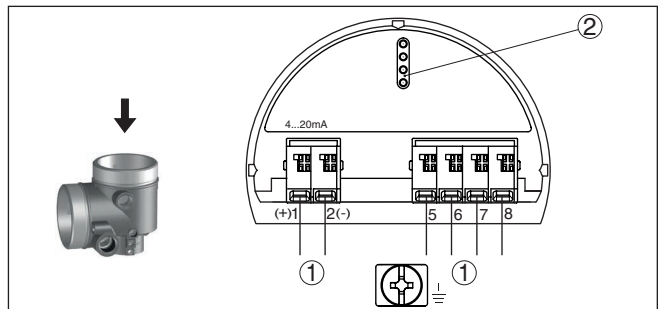

Fig. 32: Electronics compartment - Ex-d double chamber housing

1 Internal connection to the terminal compartment

2 For display and adjustment module or interface adapter

Terminal compartment

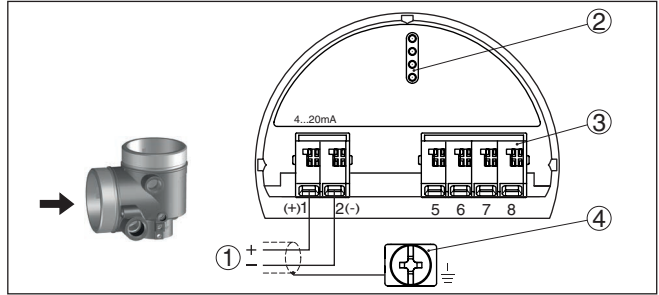

Fig. 33: Terminal compartment - double chamber housing

- 1 Voltage supply, signal output
- 2 For display and adjustment module or interface adapter
- 3 For external display and adjustment unit
- 4 Ground terminal for connection of the cable screen

5.6 Wiring plan, double chamber housing Ex d ia

Electronics compartment

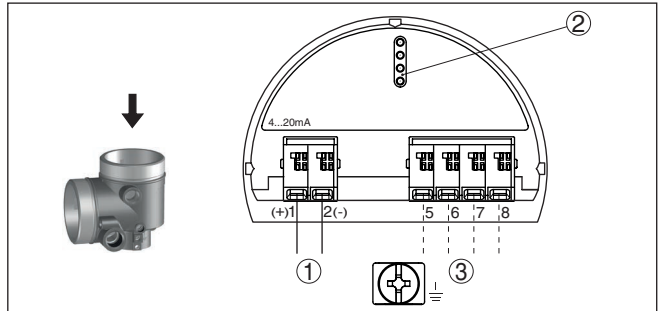

Fig. 34: Electronics compartment - Ex-d-ia double chamber housing

- 1 Internal connection to the terminal compartment
- 2 For display and adjustment module or interface adapter
- 3 Internal connection to the plug connector for external display and adjustment unit (optional)



Note:

HART multidrop mode is not possible when using an Ex-d-ia instrument.

Terminal compartment

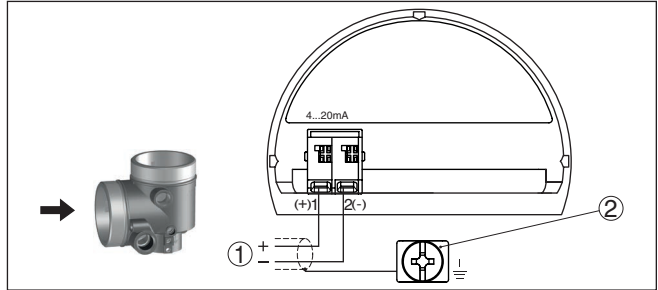

Fig. 35: Connection compartment - Ex-d-ia double chamber housing

- 1 Voltage supply, signal output
- 2 Ground terminal for connection of the cable screen

Plug M12 x 1 for external display and adjustment unit

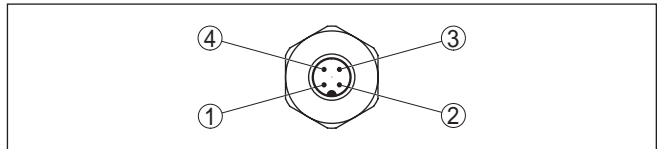

Fig. 36: Top view of the plug connector

- 1 Pin 1
- 2 Pin 2
- 3 Pin 3
- 4 Pin 4

Contact pin	Colour, connection cable in the sensor	Terminal, electronics module
Pin 1	Brown	5
Pin 2	White	6
Pin 3	Blue	7
Pin 4	Black	8

5.7 Double chamber housing with DISADAPT

Electronics compartment

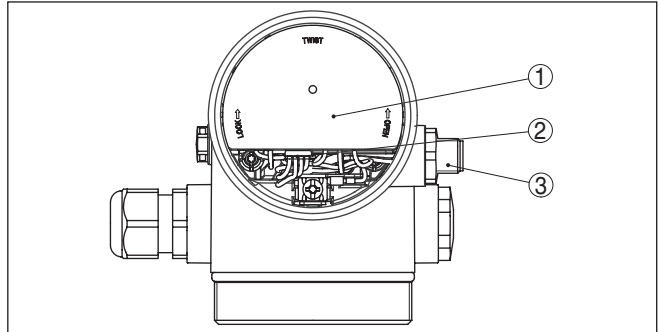

Fig. 37: View to the electronics compartment with VEGADIS adapter for connection of the external display and adjustment unit

- 1 VEGADIS adapter
- 2 Internal plug connection
- 3 Plug connector M12 x 1

Assignment of the plug connector

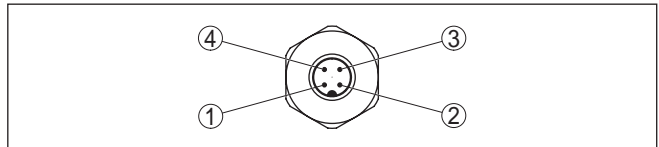

Fig. 38: View to the plug connector M12 x 1

- 1 Pin 1
- 2 Pin 2
- 3 Pin 3
- 4 Pin 4

Contact pin	Colour, connection cable in the sensor	Terminal, electronics module
Pin 1	Brown	5
Pin 2	White	6
Pin 3	Blue	7
Pin 4	Black	8

Wire assignment, connection cable**5.8 Wiring plan - version IP 66/IP 68, 1 bar**

Fig. 39: Wire assignment in permanently connected connection cable

- 1 Brown (+) and blue (-) to power supply or to the processing system
- 2 Shielding

5.9 Switch-on phase

After connecting the instrument to power supply or after a voltage recurrence, the instrument carries out a self-check for approx. 30 s:

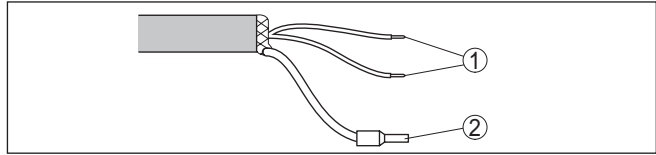
- Internal check of the electronics
- Indication of the instrument type, hardware and software version, measurement loop name on the display or PC
- Indication of the status message "*F 105 Determine measured value*" on the display or PC
- The output signal jumps to the set fault current

As soon as a plausible measured value is found, the corresponding current is outputted to the signal cable. The value corresponds to the actual level as well as the settings already carried out, e.g. factory setting.

6 Set up with the display and adjustment module

6.1 Insert display and adjustment module

The display and adjustment module can be inserted into the sensor and removed again at any time. You can choose any one of four different positions - each displaced by 90°. It is not necessary to interrupt the power supply.

Proceed as follows:

1. Unscrew the housing lid
2. Place the display and adjustment module on the electronics in the desired position and turn it to the right until it snaps in.
3. Screw housing lid with inspection window tightly back on

Disassembly is carried out in reverse order.

The display and adjustment module is powered by the sensor, an additional connection is not necessary.



Fig. 40: Installing the display and adjustment module in the electronics compartment of the single chamber housing

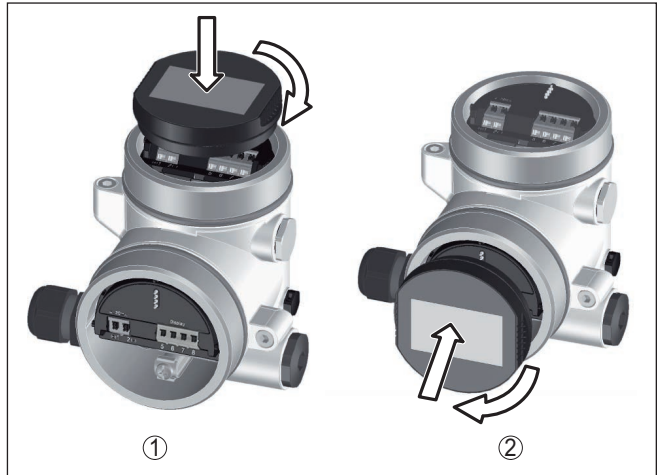

Fig. 41: Installing the display and adjustment module in the double chamber housing

- 1 In the electronics compartment
- 2 In the terminal compartment



Note:

If you intend to retrofit the instrument with a display and adjustment module for continuous measured value indication, a higher lid with an inspection glass is required.

6.2 Adjustment system

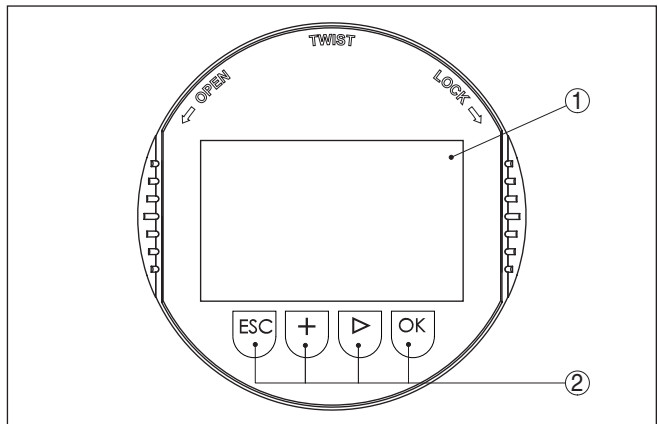

Fig. 42: Display and adjustment elements

- 1 LC display
- 2 Adjustment keys

Key functions

- **[OK]** key:

- Move to the menu overview
- Confirm selected menu
- Edit parameter
- Save value
- [->] key:
 - Change measured value presentation
 - Select list entry
 - Select menu items in the quick setup menu
 - Select editing position
- [+] key:
 - Change value of the parameter
- [ESC] key:
 - Interrupt input
 - Jump to next higher menu

Adjustment system

The instrument is operated via the four keys of the display and adjustment module. The individual menu items are shown on the LC display. You can find the function of the individual keys in the previous illustration.

Time functions

When the [+] and [->] keys are pressed quickly, the edited value, or the cursor, changes one value or position at a time. If the key is pressed longer than 1 s, the value or position changes continuously. When the [OK] and [ESC] keys are pressed simultaneously for more than 5 s, the display returns to the main menu. The menu language is then switched over to "English".

Approx. 60 minutes after the last pressing of a key, an automatic reset to measured value indication is triggered. Any values not confirmed with [OK] will not be saved.

6.3 Measured value indication - Selection of national language

Measured value indication

With the [->] key you move between three different indication modes. In the first view, the selected measured value is displayed in large digits. In the second view, the selected measured value and a corresponding bar graph presentation are displayed. In the third view, the selected measured value as well as a second selectable value, e.g. the temperature of the electronics, are displayed.

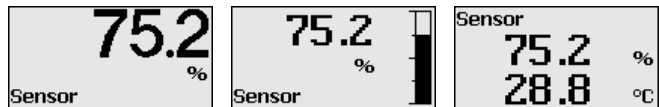

During the initial setup of an instrument shipped with factory settings, use the "OK" key to get to the menu "National language".

Selection of national language

This menu item is used to select the national language for further parameter adjustment. You can change the selection via the menu item "*Setup - Display, Menu language*".



With the "**OK**" key you move to the main menu.

6.4 Parameter adjustment - Quick setup

To quickly and easily adapt the sensor to the application, select the menu item "*Quick setup*" in the start graphic on the display and adjustment module.



Select the individual steps with the [**->**] key.

After the last step, "*Quick setup terminated successfully*" is displayed briefly.



Information:

The echo curve of setup is stored automatically during the quick setup.

The return to the measured value indication is carried out through the [**->**] or [**ESC**] keys or automatically after 3 s

You can find "*Extended adjustment*" in the next sub-chapter.

6.5 Parameter adjustment - Extended adjustment

The main menu is divided into five sections with the following functions:

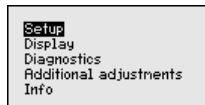

Setup: Settings, e.g., for measurement loop name, units, application, adjustment, signal output

Display: Settings, e.g., for language, measured value display, lighting

Diagnosis: Information, for example, on device status, peak value, simulation, echo curve

Additional adjustments: Date/Time, reset, copy function, scaling, current output, false signal suppression, linearization, HART mode, special parameters

Info: Instrument name, hardware and software version, calibration date, instrument features

In the main menu item "*Setup*", the individual submenu items should be selected one after the other and provided with the correct

Main menu

parameters to ensure optimum adjustment of the measurement. The procedure is described in the following.

Setup - Measurement loop name

Here you can assign a suitable measurement loop name. Push the "OK" key to start the editing. With the "+" key you change the sign and with the "->" key you jump to the next position.

You can enter names with max. 19 characters. The character set comprises:

- Capital letters from A ... Z
- Numbers from 0 ... 9
- Special characters + - / _ blanks

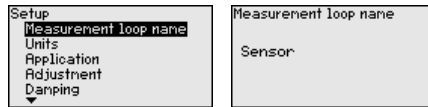

Setup - Units

In this menu item you select the distance unit and the temperature unit.

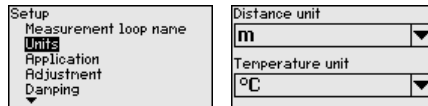

For the distance units you can choose between m, in and ft and for the temperature units °C, °F and K.

Setup - Application

With this menu item, the sensor can be optimally adapted to the application, the installation location or the measurement conditions. It includes selection options for medium, application as well as vessel height/measuring range.

Medium:

Every medium has a different reflective behaviour. With this selection, the sensor can be perfectly adapted to the medium and measurement reliability, particularly with media with poor reflective properties, is considerably increased.

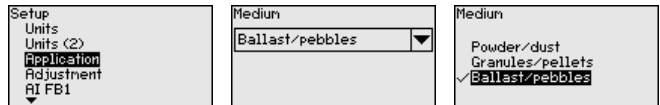

Application:

Depending on the type of bulk solids application, material cones and additional echoes from the vessel wall or bottom can become further interfering factors. Through this selection, the sensor is adapted perfectly to the application.

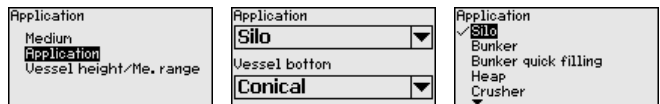

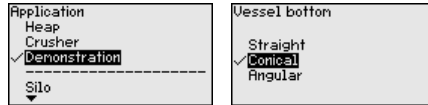

Vessel height/Measuring range:

The VEGAPULS 69 is a bulk solids radar sensor for high, slender vessels. It covers a measuring range up to 120 m. This menu item lets you limit the active measuring range in which the instrument searches for level echoes.

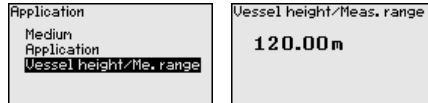

Information:

The min. adjustment must be carried out independently of this.

The following features form the basis of the applications:

Silo (slender and high):

- Vessel of metal: weld joints
- Process/measurement conditions:
 - Filling aperture too close to the sensor
 - System noise in completely empty silo increased
- Properties, sensor:
 - Stable measured values through higher averaging
 - False signal suppression during setup recommended, required for automatic false signal suppression
 - Automatic false signal suppression with partly filled vessel¹⁾

Bunker (large-volume):

- Vessel of concrete or metal:
 - Structured vessel walls
 - Installations present
- Process/measurement conditions:
 - Large distance to the medium
 - Large angles of repose
- Properties, sensor:
 - Mean averaging
 - High measured value jumps are accepted

Bunker with fast filling:

- Vessel of concrete or metal, also multiple chamber silo:
 - Structured vessel walls
 - Installations present
- Process/measurement conditions:
 - Measured value jumps, e.g. through truck loading

¹⁾ The instrument recognizes if a manual false signal suppression was carried out with empty vessel and high system noise. An automatic false signal suppression is then carried out if a product echo was detected at the beginning of the filling process.

- Large distance to the medium
- Large angles of repose
- Properties, sensor:
 - Lower averaging
 - Very high measured value jumps are accepted

Heap:

- Sensor mounting on movable conveyor belts
- Detection of the heap profile
- Height detection during filling
- Process/measurement conditions:
 - Measured value jumps, e.g. by the profile of the heap or traverses
 - Large angles of repose
 - Measurement near the filling stream
- Properties, sensor:
 - Mean averaging
 - High measured value jumps are accepted

Crusher:

- Vessel: installations, wear and protective facilities available
- Process/measurement conditions:
 - Measured value jumps, e.g. through truck loading
 - Fast reaction time
 - Large distance to the medium
- Properties, sensor:
 - Little averaging
 - Max. reaction speed, very high measured value jumps are accepted

Demonstration:

- Adjustment for all applications which are not typically level measurement
 - Instrument demonstration
 - Object recognition/monitoring (additional settings required)
- Properties, sensor:
 - Sensor accepts all measured value changes within the measuring range immediately
 - High sensitivity to interference, because virtually no averaging

Enter the requested parameters via the appropriate keys, save your settings with **[OK]** and jump to the next menu item with the **[ESC]** and the **[->]** key.

Setup - Adjustment

Since the radar sensor is a distance measuring instrument, the distance from the sensor to the product surface is measured. To indicate the actual level, an allocation of the measured distance to the percentage height must be carried out.

To perform the adjustment, enter the distance with full and empty vessel, see the following example:

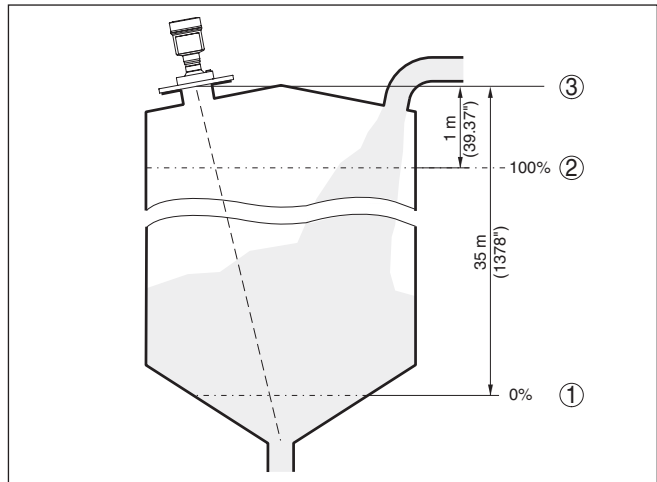

Fig. 43: Parameter adjustment example min./max. adjustment

- 1 Min. level = max. measuring distance
- 2 Max. level = min. measuring distance
- 3 Reference plane

If these values are not known, an adjustment with the distances of e.g. 10 % and 90 % is possible. Starting point for these distance specifications is always the sealing surface of the thread or flange. You can find specifications on the reference plane in chapter "Technical data". The actual level is calculated on the basis of these settings.

The actual product level during this adjustment is not important, because the min./max. adjustment is always carried out without changing the product level. These settings can be made ahead of time without the instrument having to be installed.

Setup - Max. adjustment

Proceed as follows:

1. Select with **[->]** the menu item Max. adjustment and confirm with **[OK]**.

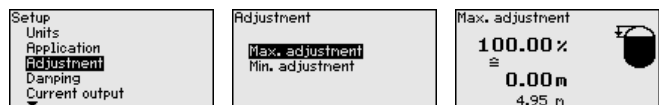

2. Prepare the percentage value for editing with **[OK]** and set the cursor to the requested position with **[->]**.

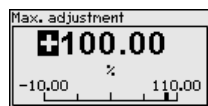

3. Set the requested percentage value with **[+]** and save with **[OK]**. The cursor jumps now to the distance value.

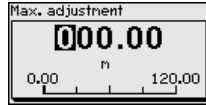

- For the full vessel, enter the distance value in m matching the percentage value.
- Save settings with **[OK]** and move with **[ESC]** and **[->]** to Min. adjustment.

Setup - Min. adjustment

Proceed as follows:

- Select with **[->]** the menu item "Min. adjustment" and confirm with **[OK]**.

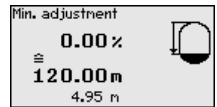
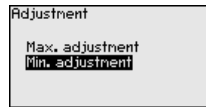
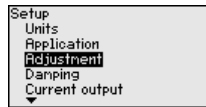

- Edit the percentage value with **[OK]** and set the cursor to the requested position with **[->]**.

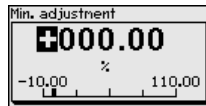

- Set the requested percentage value with **[+]** and save with **[OK]**. The cursor jumps now to the distance value.

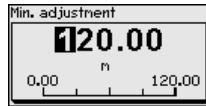

- Enter the suitable distance value in m for the empty vessel (e.g. distance from the sensor to the vessel bottom) corresponding to the percentage value.

Setup - Damping

To damp process-dependent measured value fluctuations, set an integration time of 0 ... 999 s in this menu item.

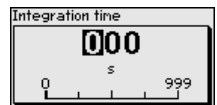
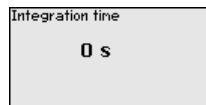
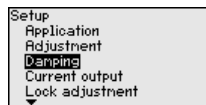

The default setting is a damping of 0 s.

Setup - Current output, mode

In the menu item "Current output mode" you determine the output characteristics and reaction of the current output in case of failure.

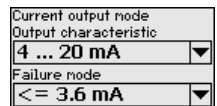
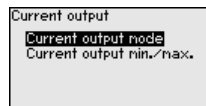
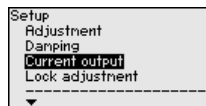

The default setting is output characteristics 4 ... 20 mA, fault mode < 3.6 mA.

Setup - Current output Min./Max.

In the menu item "Current output Min./Max.", you determine the reaction of the current output during operation.

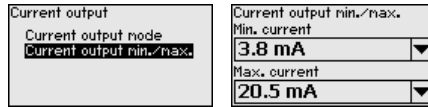

The default setting is min. current 3.8 mA and max. current 20.5 mA.

Lock/unlock setup - Adjustment

In the menu item "Lock/unlock adjustment" you safeguard the sensor parameters against unauthorized or unintentional modifications.

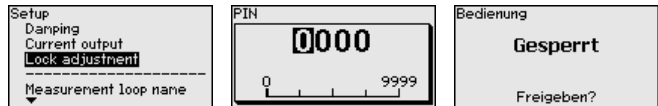

With active PIN, only the following adjustment functions are possible without entering a PIN:

- Select menu items and show data
- Read data from sensor into the display and adjustment module.

Releasing the sensor adjustment is also possible in any menu item by entering the PIN.



Caution:

With active PIN, adjustment via PACTware/DTM and other systems is also blocked.

Display - Menu language

This menu item enables the setting of the requested national language.

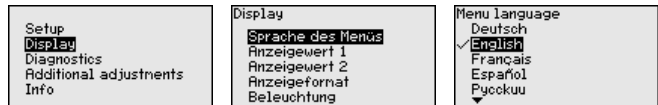

The following languages are available:

- German
- English
- French
- Spanish
- Russian
- Italian
- Dutch
- Portuguese
- Japanese
- Chinese
- Polish
- Czech
- Turkish

In the delivery status, the VEGAPULS 69 is set to the ordered national language.

Display - Displayed value 1 and 2

In this menu item you can define the way measured values are indicated on the display.

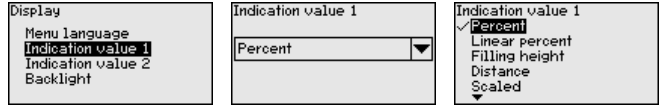

The default setting for the display value is "Percent".

Display - Backlight

The display and adjustment module has a backlight for the display. In this menu item you can switch the lighting on or off. You can find the required operating voltage in chapter "Technical data".

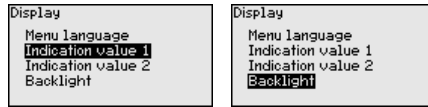

In delivery status, the lighting is switched on.

Diagnostics - Device status

In this menu item, the device status is displayed.

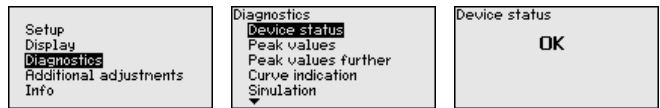

Diagnosis - Peak value

The min. and max. measured value, the measurement certainty as well as the min. and max. electronics temperature are stored in the sensor. The values are displayed in menu item "Peak value" or "Further peak values".

A reset menu is opened with the [OK] key in the respective peak value window:

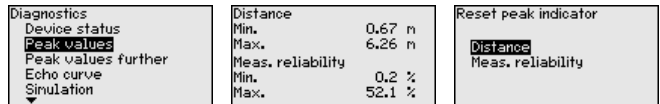

With the [OK] key in the reset menu, the peak values are reset to the current measured value.

Diagnoses - Curve indication

The "Echo curve" shows the signal strength of the echoes over the measuring range in dB. The signal strength enables an evaluation of the quality of the measurement.

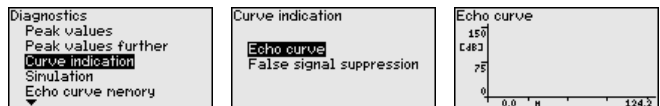

The selected curve is continuously updated. A submenu with zoom functions is opened with the [OK] key:

- "X-Zoom": Zoom function for the meas. distance
- "Y-Zoom": 1, 2, 5 and 10x signal magnification in "dB"
- "Unzoom": Reset the presentation to the nominal measuring range without magnification

Diagnosis - Simulation

In this menu item you can simulate measured values via the current output. This allows the signal path to be tested, e.g. through downstream indicating instruments or the input card of the control system.

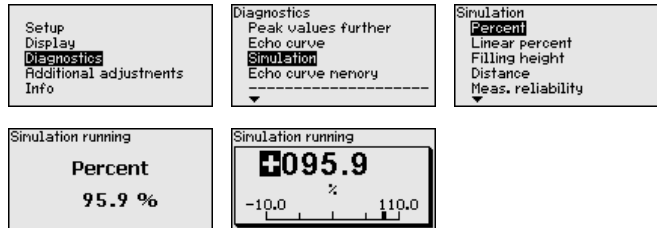

Select the requested simulation variable and set the requested value.

**Caution:**

During simulation, the simulated value is outputted as 4 ... 20 mA current value and as digital HART signal. The status message within the context of the asset management function is "Maintenance".

To deactivate the simulation, you have to push the **[ESC]** key and confirm the message

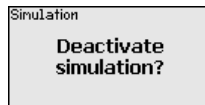

with the **[OK]** key.

**Information:**

The sensor terminates the simulation automatically after 60 minutes.

Diagnostics - Echo curve memory

The function "Setup" allows the echo curve to be saved at the time of setup.

**Information:**

This is generally recommended, however, for use of the Asset Management functions it is absolutely necessary. Saving should be carried out with a very low level.

The function "Echo curve memory" allows up to ten individual echo curves to be stored, for example to detect the measurement behaviour of the sensor in different operating conditions.

With the adjustment software PACTware and the PC, the stored echo curves can be displayed with high resolution and used to recognize signal changes over time. In addition, the echo curve saved during setup can also be displayed in the echo curve window and compared with the current echo curve.

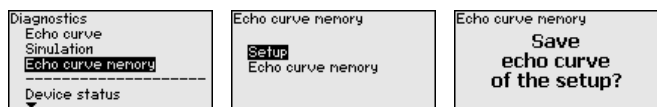

Additional settings - Date/Time

In this menu item, the internal clock of the sensor is set to the requested time and time format. At the time of shipment from factory, the instrument is set to CET (Central European Time).

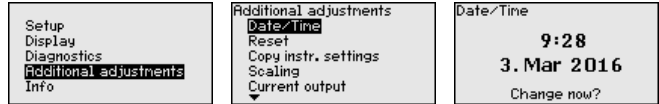

Additional adjustments - Reset

During a reset, the parameter settings carried out by the user are reset to the default values (see below table).

Proceed as follows:

1. Select with **[->]** under "Additional adjustments" the menu item "Reset" and confirm with **[OK]**.

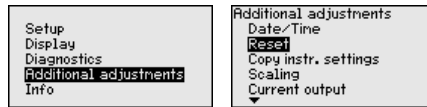

2. Confirm with **[OK]** and select the requested reset function with **[->]**



3. Confirm with **[OK]**, for approx. 5 s the message "Resetting" is displayed, then the selection window appears.

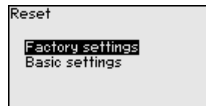

Caution:

For the duration of the reset, the set trouble signal is outputted via the current output. Within the context of the asset management function, the message "Maintenance" is outputted.

The following reset functions are available:

Delivery status: Restores the parameter settings at the time of shipment from the factory, incl. the order-specific settings. Any created false signal suppression, user-programmable linearization curve as well as measured value and echo curve memory is deleted. The event and parameter modification memories remain unaffected.

Basic settings: Resets the parameter settings, incl. special parameters, to the default values of the respective instrument. Any stored false signal suppression or user programmable linearisation curve, as well as the measured value memory, is deleted. Order-related settings are not taken over into the current parameters after this reset.

The following table shows the scope of the reset function and the default values of the instrument:

Menu	Menu item	Default value
Setup	Measurement loop name	Sensor
	Units	Distance in m Temperature in °C
	Application	Medium: Crushed stones/gravel Application: Silo Vessel bottom: Flat Vessel height/Measuring range: 120 m
	Min. adjustment	120 m
	Max. adjustment	0,000 m(d)
	Damping	0.0 s
	Current output mode	Output characteristics: 4 ... 20 mA Failure mode: < 3.6 mA ▼
	Current output Min./Max.	Min. current: 3.8 mA Max. current: 20.5 mA
Display	Displayed value 1	Filling height
	Displayed value 2	Temperature
	Backlight	Switched off
Additional adjustments	Date/Time	Time format: 24 h
	Scaling size	Volume l
	Scaling format	100.00 lin %, 100 l 0.00 lin %, 0 l
	Current output 1 and 2 size	Lin %
	Current output 1 and 2 adjustment	100.00 %, 100 l 0.00 %, 0 l
	Linearization	Linear
	HART mode	HART address: 0 Loop current mode: Analogue current output

Additional settings - Copy instrument settings

The instrument settings are copied with this function. The following functions are available:

Read from sensor: Read data from sensor and store into the display and adjustment module

Write into sensor: Store data from the display and adjustment module back into the sensor

The following data or settings for adjustment of the display and adjustment module are saved:

- All data of the menu "Setup" and "Display"

- The menu items "Reset, Date/Time" in the menu "Additional settings"
- The user-programmable linearization curve

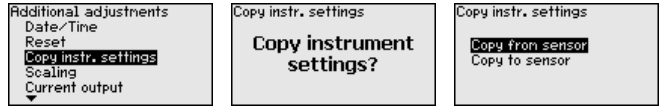

The copied data are permanently saved in an EEPROM memory in the display and adjustment module and remain there even in case of power failure. From there, they can be written into one or more sensors or kept as backup for a possible electronics exchange.



Note:

Before the data are saved in the sensor, a safety check is carried out to determine if the data match the sensor. In the process the sensor type of the source data as well as the target sensor are displayed. If the data do not match, a fault message is outputted or the function is blocked. The data are saved only after release.

Additional settings - Scaling

In the menu item "Scaling" you define the scaling variable and the scaling format for the indication of the level measured value for 0 % and 100 % on the display, for example as volume in l.

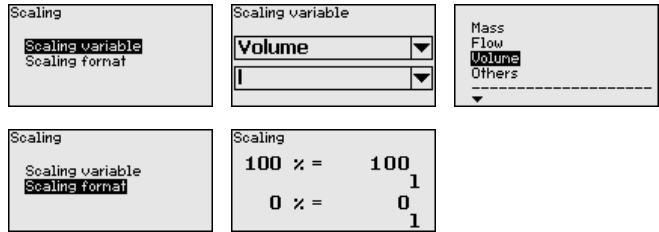

Additional settings - Current output (size)

In menu item "Current output, variable" you specify which measured variable the current output refers to.

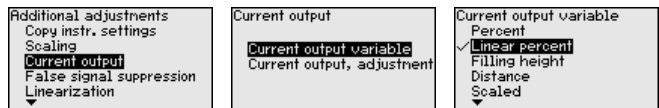

Additional settings - Current output (adjustment)

In menu item "Current output, adjustment" you can assign a respective measured value to the current output.

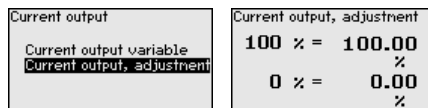

Additional adjustments - False signal suppression

The following circumstances cause interfering reflections and can influence the measurement:

- High sockets
- Vessel internals such as struts

- Agitators
- Buildup or welded joints on vessel walls

**Note:**

A false signal suppression detects, marks and saves these false signals so that they are no longer taken into account in the level measurement.

This should be done with the lowest possible level so that all potential interfering reflections can be detected.

Proceed as follows:

1. Select with **[>]** the menu item "*False signal suppression*" and confirm with **[OK]**.

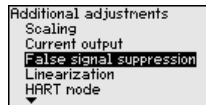

2. Confirm again with **[OK]**.



3. Confirm again with **[OK]**.

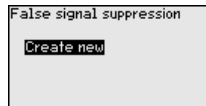

4. Confirm again with **[OK]** and enter the actual distance from the sensor to the product surface.

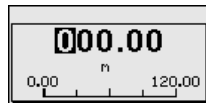

5. All interfering signals in this section are detected by the sensor and stored after confirming with **[OK]**.

**Note:**

Check the distance to the product surface, because if an incorrect (too large) value is entered, the existing level will be saved as a false signal. The level would then no longer be detectable in this area.

If a false signal suppression has already been saved in the sensor, the following menu window appears when selecting "*False signal suppression*":

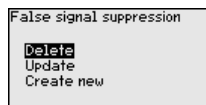

Delete: An already created false signal suppression will be completely deleted. This is useful if the saved false signal suppression no longer matches the metrological conditions in the vessel.

Extend: is used to extend an already created false signal suppression. This is useful if a false signal suppression was carried out with too high a level and not all false signals could be detected. When selecting "Extend", the distance to the product surface of the created false signal suppression is displayed. This value can now be changed and the false signal suppression can be extended to this range.

Additional settings - Linearization

A linearization is necessary for all vessels in which the vessel volume does not increase linearly with the level. Corresponding linearization curves are preprogrammed for these vessels. They represent the correlation between the level percentage and vessel volume. The linearization applies to the measured value indication and the current output.

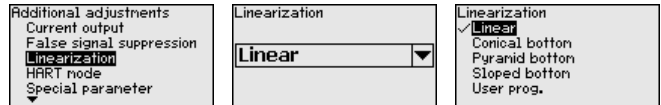

Additional adjustments - HART mode

In this menu item you specify the HART mode and enter the address for multidrop mode.

In the mode "Fixed current output" up to 63 sensors can be operated on one two-wire cable (Multidrop operation). An address between 0 and 63 must be assigned to each sensor.

If you select the function "Analogue current output", a 4 ... 20 mA signal is output in multidrop mode.

In the mode "Fixed current (4 mA)" a fixed 4 mA signal is output independently of the actual level.

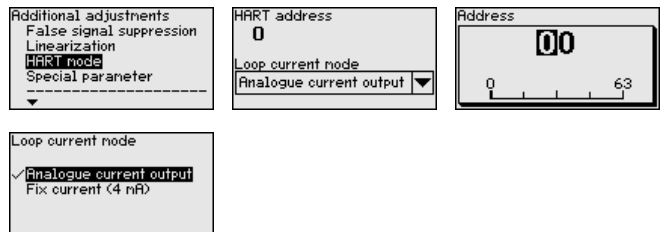

The default setting is "Analogue current output" and the address "00".

Additional settings - Special parameters

In this menu item you gain access to the protected area where you can enter special parameters. In exceptional cases, individual parameters can be modified in order to adapt the sensor to special requirements.

Change the settings of the special parameters only after having contacted our service staff.

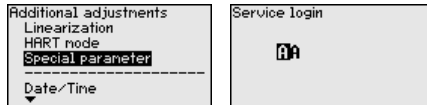

Info - Instrument name In this menu item, you can read out the instrument name and the instrument serial number:

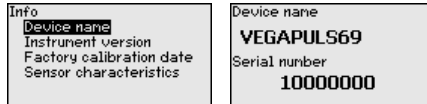

Info - Instrument version In this menu item, the hardware and software version of the sensor is displayed.

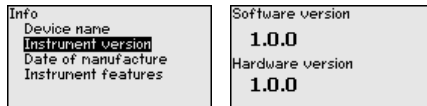

Info - Factory calibration date In this menu item, the date of factory calibration of the sensor as well as the date of the last change of sensor parameters are displayed via the display and adjustment module or via the PC.

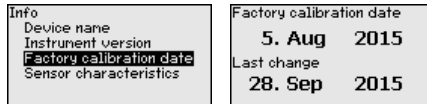

Info - Sensor characteristics In this menu item, the features of the sensor such as approval, process fitting, seal, measuring range, electronics, housing and others are displayed.

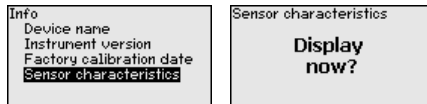

6.6 Saving the parameterisation data

Backup on paper

We recommended writing down the adjustment data, e.g. in this operating instructions manual, and archiving them afterwards. They are thus available for multiple use or service purposes.

Backup in the display and adjustment module

If the instrument is equipped with a display and adjustment module, the data in the sensor can be saved in the display and adjustment module. The procedure is described in menu item "Copy device settings" in the menu "Additional settings". The data remain there permanently even if the sensor power supply fails.

The following data or settings for adjustment of the display and adjustment module are saved:

- All data of the menu "Setup" and "Display"

- The items "*Sensor-specific units, temperature unit and linearisation*" in the menu "*Additional settings*".
- The values of the user-programmable linearisation curve

The function can also be used to transfer settings from one instrument to another instrument of the same type. If it is necessary to exchange a sensor, the display and adjustment module is inserted into the replacement instrument and the data are likewise written into the sensor via the menu item "*Copy device settings*".

7 Setup with PACTware

7.1 Connect the PC

Via the interface adapter directly on the sensor



Fig. 44: Connection of the PC directly to the sensor via the interface adapter

- 1 USB cable to the PC
- 2 Interface adapter VEGACONNECT
- 3 Sensor

Via the interface adapter and HART

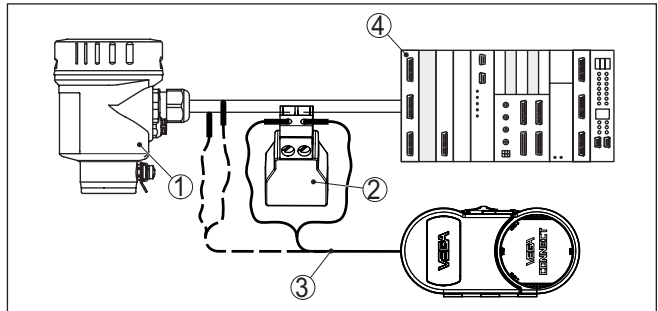

Fig. 45: Connecting the PC via HART to the signal cable

- 1 Sensor
- 2 HART resistance 250 Ω (optional depending on evaluation)
- 3 Connection cable with 2 mm pins and terminals
- 4 Processing system/PLC/Voltage supply
- 5 Interface adapter, for example VEGACONNECT 4



Note:

With power supply units with integrated HART resistance (internal resistance approx. 250 Ω), an additional external resistance is not necessary. This applies, e.g. to the VEGA instruments VEGATRENN 149A, VEGAMET 381, VEGAMET 391. Common Ex separators are

also usually equipped with a sufficient current limiting resistance. In such cases, the interface converter can be connected parallel to the 4 ... 20 mA cable (dashed line in the previous illustration).

7.2 Parameter adjustment

Prerequisites

For parameter adjustment of the instrument via a Windows PC, the configuration software PACTware and a suitable instrument driver (DTM) according to FDT standard are required. The latest PACTware version as well as all available DTMs are compiled in a DTM Collection. The DTMs can also be integrated into other frame applications according to FDT standard.



Note:

To ensure that all instrument functions are supported, you should always use the latest DTM Collection. Furthermore, not all described functions are included in older firmware versions. You can download the latest instrument software from our homepage. A description of the update procedure is also available in the Internet.

Further setup steps are described in the operating instructions manual "DTM Collection/PACTware" attached to each DTM Collection and which can also be downloaded from the Internet. Detailed descriptions are available in the online help of PACTware and the DTMs.

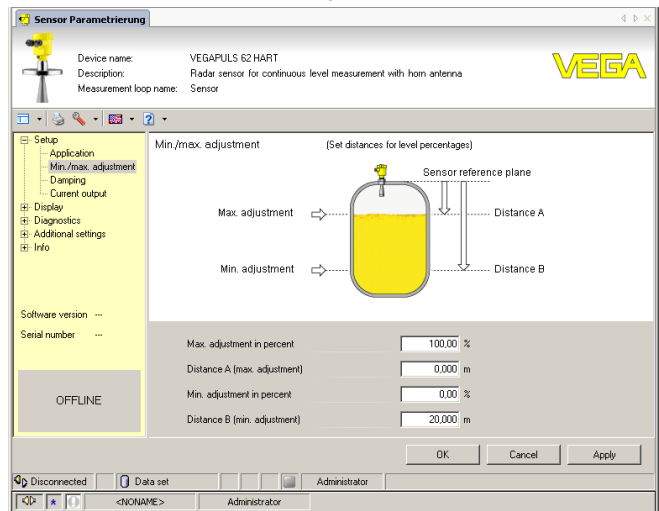

Fig. 46: Example of a DTM view

Standard/Full version

All device DTMs are available as a free-of-charge standard version and as a full version that must be purchased. In the standard version, all functions for complete setup are already included. An assistant for simple project configuration simplifies the adjustment considerably. Saving/printing the project as well as import/export functions are also part of the standard version.

In the full version there is also an extended print function for complete project documentation as well as a save function for measured value and echo curves. In addition, there is a tank calculation program as well as a multiviewer for display and analysis of the saved measured value and echo curves.

The standard version is available as a download under www.vega.com/downloads and "*Software*". The full version is available on CD from the agency serving you.

7.3 Saving the parameterisation data

We recommend documenting or saving the parameterisation data via PACTware. That way the data are available for multiple use or service purposes.

8 Set up with other systems

8.1 DD adjustment programs

Device descriptions as Enhanced Device Description (EDD) are available for DD adjustment programs such as, for example, AMS™ and PDM.

The files can be downloaded at www.vega.com/downloads under "Software".

8.2 Field Communicator 375, 475

Device descriptions for the instrument are available as EDD for parameterisation with Field Communicator 375 or 475.

Integrating the EDD into the Field Communicator 375 or 475 requires the "Easy Upgrade Utility" software, which is available from the manufacturer. This software is updated via the Internet and new EDDs are automatically accepted into the device catalogue of this software after they are released by the manufacturer. They can then be transferred to a Field Communicator.

9 Diagnosis, asset management and service

9.1 Maintenance

If the instrument is used correctly, no maintenance is required in normal operation.

In some applications, buildup on the antenna system can influence the measuring result. Depending on the sensor and application, take measures to avoid heavy soiling of the antenna system. If necessary, clean the antenna system in certain intervals.

9.2 Measured value and event memory

The instrument has several memories available for diagnostic purposes. The data remain there even in case of voltage interruption.

Measured value memory

Up to 100,000 measured values can be stored in the sensor in a ring memory. Each entry contains date/time as well as the respective measured value. Storable values are for example:

- Distance
- Filling height
- Percentage value
- Lin. percent
- Scaled
- Current value
- Meas. certainty
- Electronics temperature

When the instrument is shipped, the measured value memory is active and stores distance, measurement certainty and electronics temperature every 3 minutes.

The requested values and recording conditions are set via a PC with PACTware/DTM or the control system with EDD. Data are thus read out and also reset.

Event memory

Up to 500 events are automatically stored with a time stamp in the sensor (non-deletable). Each entry contains date/time, event type, event description and value. Event types are for example:

- Modification of a parameter
- Switch-on and switch-off times
- Status messages (according to NE 107)
- Error messages (according to NE 107)

The data are read out via a PC with PACTware/DTM or the control system with EDD.

Echo curve memory

The echo curves are stored with date and time and the corresponding echo data. The memory is divided into two sections:

Echo curve of the setup: This is used as reference echo curve for the measurement conditions during setup. Changes in the measurement conditions during operation or buildup on the sensor can thus be recognized. The echo curve of the setup is stored via:

- PC with PACTware/DTM
- Control system with EDD
- Display and adjustment module

Further echo curves: Up to 10 echo curves can be stored in a ring buffer in this memory section. Additional echo curves are stored via:

- PC with PACTware/DTM
- Control system with EDD

9.3 Asset Management function

The instrument features self-monitoring and diagnostics according to NE 107 and VDI/VDE 2650. In addition to the status messages in the following tables, detailed error messages are available under menu item "Diagnostics" via the display and adjustment module, PACTware/DTM and EDD.

Status messages

The status messages are divided into the following categories:

- Failure
- Function check
- Out of specification
- Maintenance requirement

and explained by pictographs:

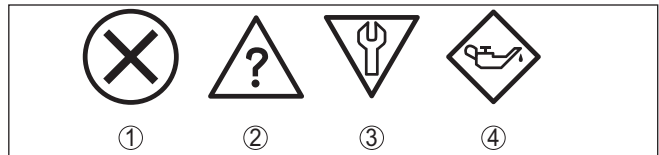

Fig. 47: Pictographs of the status messages

- 1 Failure - red
- 2 Out of specification - yellow
- 3 Function check - orange
- 4 Maintenance - blue

Failure: Due to a malfunction in the instrument, a fault message is outputted.

This status message is always active. It cannot be deactivated by the user.

Function check: The instrument is being worked on, the measured value is temporarily invalid (for example during simulation).

This status message is inactive by default. It can be activated by the user via PACTware/DTM or EDD.

Out of specification: The measured value is unreliable because an instrument specification was exceeded (e.g. electronics temperature).

This status message is inactive by default. It can be activated by the user via PACTware/DTM or EDD.

Maintenance: Due to external influences, the instrument function is limited. The measurement is affected, but the measured value is

still valid. Plan in maintenance for the instrument because a failure is expected in the near future (e.g. due to buildup).

This status message is inactive by default. It can be activated by the user via PACTware/DTM or EDD.

Failure

The following table shows the error codes in the status message "Failure" and gives information on the reason and rectification. Keep in mind that some information is only valid for four-wire instruments.

Code Text message	Reason	Removal	DevSpec State in CMD 48
F013 no measured value available	<ul style="list-style-type: none"> ● Sensor does not detect an echo during operation ● Antenna system dirty or defective 	<ul style="list-style-type: none"> ● Check or correct installation and/or parameter settings ● Clean or exchange process component or antenna 	Bit 0 of Byte 0 ... 5
F017 Adjustment span too small	<ul style="list-style-type: none"> ● Adjustment not within specification 	<ul style="list-style-type: none"> ● Change adjustment according to the limit values (difference between min. and max. ≥ 10 mm) 	Bit 1 of Byte 0 ... 5
F025 Error in the linearization table	<ul style="list-style-type: none"> ● Index markers are not continuously rising, for example illogical value pairs 	<ul style="list-style-type: none"> ● Check linearisation table ● Delete table/Create new 	Bit 2 of Byte 0 ... 5
F036 No operable software	<ul style="list-style-type: none"> ● Failed or interrupted software update 	<ul style="list-style-type: none"> ● Repeat software update ● Check electronics version ● Exchanging the electronics ● Send instrument for repair 	Bit 3 of Byte 0 ... 5
F040 Error in the electronics	<ul style="list-style-type: none"> ● Hardware defect 	<ul style="list-style-type: none"> ● Exchanging the electronics ● Send instrument for repair 	Bit 4 of Byte 0 ... 5
F080 General software error	<ul style="list-style-type: none"> ● General software error 	<ul style="list-style-type: none"> ● Disconnect operating voltage briefly 	Bit 5 of Byte 0 ... 5
F105 Determine measured value	<ul style="list-style-type: none"> ● The instrument is still in the start phase, the measured value could not yet be determined 	<ul style="list-style-type: none"> ● Wait for the end of the switch-on phase ● Duration up to approx. 3 min. depending on the version and parameter settings 	Bit 6 of Byte 0 ... 5
F113 Communication error	<ul style="list-style-type: none"> ● EMC interference ● Transmission error during external communication with 4-wire power supply unit 	<ul style="list-style-type: none"> ● Remove EMC influences ● Exchange 4-wire power supply unit or electronics 	Bit 12 of Byte 0 ... 5
F125 Impermissible electronics temperature	<ul style="list-style-type: none"> ● Temperature of the electronics in the non-specified range 	<ul style="list-style-type: none"> ● Check ambient temperature ● Insulate electronics ● Use instrument with higher temperature range 	Bit 7 of Byte 0 ... 5
F260 Error in the calibration	<ul style="list-style-type: none"> ● Error in the calibration carried out in the factory ● Error in the EEPROM 	<ul style="list-style-type: none"> ● Exchanging the electronics ● Send instrument for repair 	Bit 8 of Byte 0 ... 5

Code Text message	Reason	Removal	DevSpec State in CMD 48
F261 Error in the instrument settings	<ul style="list-style-type: none"> ● Error during setup ● False signal suppression faulty ● Error when carrying out a reset 	<ul style="list-style-type: none"> ● Repeat setup ● Carry out a reset 	Bit 9 of Byte 0 ... 5
F264 Installation/Setup error	<ul style="list-style-type: none"> ● Adjustment not within the vessel height/measuring range ● Max. measuring range of the instrument not sufficient 	<ul style="list-style-type: none"> ● Check or correct installation and/or parameter settings ● Use an instrument with bigger measuring range 	Bit 10 of Byte 0 ... 5
F265 Measurement function disturbed	<ul style="list-style-type: none"> ● Sensor no longer carries out a measurement ● Operating voltage too low 	<ul style="list-style-type: none"> ● Check operating voltage ● Carry out a reset ● Disconnect operating voltage briefly 	Bit 11 of Byte 0 ... 5

Function check

The following table shows the error codes and text messages in the status message "*Function check*" and provides information on causes as well as corrective measures.

Code Text message	Reason	Removal	DevSpec State in CMD 48
C700 Simulation active	<ul style="list-style-type: none"> ● A simulation is active 	<ul style="list-style-type: none"> ● Finish simulation ● Wait for the automatic end after 60 mins. 	"Simulation Active" in "Standardized Status 0"

Out of specification

The following table shows the error codes and text messages in the status message "*Out of specification*" and provides information on causes as well as corrective measures.

Code Text message	Reason	Removal	DevSpec State in CMD 48
S600 Impermissible electronics temperature	<ul style="list-style-type: none"> ● Temperature of the electronics in the non-specified range 	<ul style="list-style-type: none"> ● Check ambient temperature ● Insulate electronics ● Use instrument with higher temperature range 	Bit 8 of Byte 14 ... 24
S601 Overfilling	<ul style="list-style-type: none"> ● Danger of vessel overfilling 	<ul style="list-style-type: none"> ● Make sure that there is no further filling ● Check level in the vessel 	Bit 9 of Byte 14 ... 24
S603 Impermissible operating voltage	<ul style="list-style-type: none"> ● Operating voltage below specified range 	<ul style="list-style-type: none"> ● Check electrical connection ● If necessary, increase operating voltage 	Bit 11 of Byte 14 ... 24

Maintenance

The following table shows the error codes and text messages in the status message "*Maintenance*" and provides information on causes as well as corrective measures.

Code Text message	Reason	Removal	DevSpec State in CMD 48
M500 Error during the reset "delivery status"	<ul style="list-style-type: none"> ● The data could not be restored during the reset to delivery status 	<ul style="list-style-type: none"> ● Repeat reset ● Load XML file with sensor data into the sensor 	Bit 0 of Byte 14 ... 24

Code Text message	Reason	Removal	DevSpec State in CMD 48
M501 Error in the non-active linearisation table	<ul style="list-style-type: none"> ● Hardware error EEPROM 	<ul style="list-style-type: none"> ● Exchanging the electronics ● Send instrument for repair 	Bit 1 of Byte 14 ... 24
M502 Error in the event memory	<ul style="list-style-type: none"> ● Hardware error EEPROM 	<ul style="list-style-type: none"> ● Exchanging the electronics ● Send instrument for repair 	Bit 2 of Byte 14 ... 24
M503 Measurement reliability too low	<ul style="list-style-type: none"> ● The echo/noise ratio is too small for reliable measurement ● Antenna dirty or defective 	<ul style="list-style-type: none"> ● Check installation and process conditions ● Change polarisation direction ● Use instrument with higher sensitivity ● Clean the antenna 	Bit 3 of Byte 14 ... 24
M504 Error at a device interface	<ul style="list-style-type: none"> ● Hardware defect 	<ul style="list-style-type: none"> ● Check connections ● Exchanging the electronics ● Send instrument for repair 	Bit 4 of Byte 14 ... 24
M505 No echo available	<ul style="list-style-type: none"> ● Sensor does not detect an echo during operation ● Antenna dirty or defective 	<ul style="list-style-type: none"> ● Clean the antenna ● Use a more suitable antenna/sensor ● Remove possible false echoes ● Optimize sensor position and orientation 	Bit 5 of Byte 14 ... 24
M506 Installation/Setup error	<ul style="list-style-type: none"> ● Error during setup 	<ul style="list-style-type: none"> ● Check or correct installation and/or parameter settings 	Bit 6 of Byte 14 ... 24
M507 Error in the instrument settings	<ul style="list-style-type: none"> ● Error during setup ● Error when carrying out a reset ● False signal suppression faulty 	<ul style="list-style-type: none"> ● Carry out reset and repeat setup 	Bit 7 of Byte 14 ... 24

9.4 Rectify faults

Reaction when malfunction occurs

The operator of the system is responsible for taking suitable measures to rectify faults.

Procedure for fault rectification

The first measures are:

- Evaluation of fault messages via the adjustment device
- Checking the output signal
- Treatment of measurement errors

Further comprehensive diagnostics options are available with a PC with PACTware and the suitable DTM. In many cases, the reasons can be determined in this way and faults rectified.

Check the 4 ... 20 mA signal

Connect a multimeter in the suitable measuring range according to the wiring plan. The following table describes possible errors in the current signal and helps to eliminate them:

Error	Reason	Removal
4 ... 20 mA signal not stable	<ul style="list-style-type: none"> ● Fluctuations of the measured variable 	<ul style="list-style-type: none"> ● Set damping appropriate to the instrument via the display and adjustment module or PACTware/DTM
4 ... 20 mA signal missing	<ul style="list-style-type: none"> ● Electrical connection faulty 	<ul style="list-style-type: none"> ● Check connection according to chapter "Connection steps" and if necessary, correct according to chapter "Wiring plan"
	<ul style="list-style-type: none"> ● Voltage supply missing 	<ul style="list-style-type: none"> ● Check cables for breaks; repair if necessary
	<ul style="list-style-type: none"> ● Operating voltage too low or load resistance too high 	<ul style="list-style-type: none"> ● Check, adapt if necessary
Current signal greater than 22 mA or less than 3.6 mA	<ul style="list-style-type: none"> ● Electronics module in the sensor defective 	<ul style="list-style-type: none"> ● Exchange the instrument or send it in for repair

Treatment of measurement errors with bulk solids

The below tables show typical examples of application-related measurement errors with bulk solids. A distinction is made between measurement errors during:

- Constant level
- Filling
- Emptying

The images in column "Error pattern" show the real level as a broken line and the level displayed by the sensor as a continuous line.

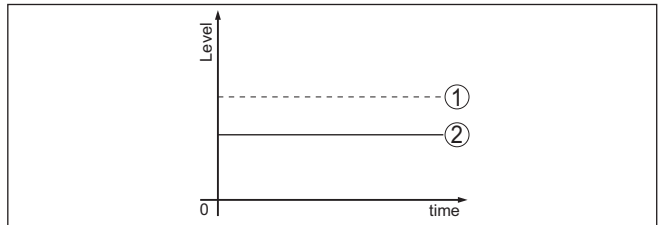

- 1 Real level
- 2 Level displayed by the sensor

Notes:

- Whenever the sensor displays a constant value, the reason could also be that the fault setting of the current output is set to "Hold value"
- If the level indication is too low, the reason could be a line resistance that is too high

Measurement error with constant level

Fault description	Error pattern	Cause	Rectification
1. Measured value shows a too low or too high level		<ul style="list-style-type: none"> ● Min./max. adjustment not correct 	<ul style="list-style-type: none"> ● Adapt min./max. adjustment
		<ul style="list-style-type: none"> ● Incorrect linearization curve 	<ul style="list-style-type: none"> ● Adapt linearization curve



47247-EN-170315

Fault description	Error pattern	Cause	Rectification
2. Measured value jumps towards 100 %		<ul style="list-style-type: none"> ● Due to the process, the amplitude of the product echo decreases ● A false signal suppression was not carried out 	<ul style="list-style-type: none"> ● Carry out a false signal suppression
		<ul style="list-style-type: none"> ● Amplitude or position of a false signal has changed (e.g. condensation, buildup); false signal suppression no longer matches actual conditions 	<ul style="list-style-type: none"> ● Determine the reason for the changed false signals, carry out false signal suppression, e.g. with condensation

Measurement error during filling

Fault description	Error pattern	Cause	Rectification
3. Measured value jumps towards 0 % during filling		<ul style="list-style-type: none"> ● Amplitude of a multiple echo (vessel top - product surface) is larger than the level echo 	<ul style="list-style-type: none"> ● Check parameter "Application", especially vessel top, type of medium, dished bottom, high dielectric constant, and adapt if necessary
		<ul style="list-style-type: none"> ● The level echo cannot be distinguished from the false signal at a false signal position (jumps to multiple echo) 	<ul style="list-style-type: none"> ● Remove/reduce false signal: minimize interfering installations by changing the polarization direction ● Chose a more suitable installation position
		<ul style="list-style-type: none"> ● Transverse reflection from an extraction funnel, amplitude of the transverse reflection larger than the level echo 	<ul style="list-style-type: none"> ● Direct sensor to the opposite funnel wall, avoid crossing with the filling stream
4. Measured value fluctuates around 10 ... 20 %		<ul style="list-style-type: none"> ● Various echoes from an uneven product surface, e.g. a material cone 	<ul style="list-style-type: none"> ● Check parameter "Type of medium" and adapt, if necessary ● Optimize installation position and sensor orientation
		<ul style="list-style-type: none"> ● Reflections from the product surface via the vessel wall (deflection) 	<ul style="list-style-type: none"> ● Select a more suitable installation position, optimize sensor orientation, e.g. with a swivelling holder
5. Measured value jumps sporadically to 100 % during filling		<ul style="list-style-type: none"> ● Changing condensation or contamination on the antenna 	<ul style="list-style-type: none"> ● Carry out a false signal suppression or increase false signal suppression with condensation/contamination in the close range by editing ● With bulk solids use radar sensor with purging air connection or flexible antenna cover

Measurement error during emptying

Fault description	Error pattern	Cause	Rectification
6. Measured value remains unchanged in the close range during emptying		<ul style="list-style-type: none"> ● False signal larger than the level echo ● Level echo too small 	<ul style="list-style-type: none"> ● Eliminate false signals in the close range. Check: Antenna must protrude out of the socket ● Remove contamination on the antenna ● Minimize interfering installations in the close range by changing the polarization direction ● After eliminating the false signals, the false signal suppression must be deleted. Carry out a new false signal suppression
7. Measured value jumps sporadically towards 100 % during emptying		<ul style="list-style-type: none"> ● Changing condensation or contamination on the antenna 	<ul style="list-style-type: none"> ● Carry out false signal suppression or increase false signal suppression in the close range by editing ● With bulk solids use radar sensor with purging air connection or flexible antenna cover
8. Measured value fluctuates around 10 ... 20 %		<ul style="list-style-type: none"> ● Various echoes from an uneven product surface, e.g. an extraction funnel ● Reflections from the product surface via the vessel wall (deflection) 	<ul style="list-style-type: none"> ● Check parameter "Type of medium" and adapt, if necessary ● Optimize installation position and sensor orientation

Reaction after fault rectification

Depending on the reason for the fault and the measures taken, the steps described in chapter "Setup" must be carried out again or must be checked for plausibility and completeness.

24 hour service hotline

Should these measures not be successful, please call in urgent cases the VEGA service hotline under the phone no. **+49 1805 858550**.

The hotline is also available outside normal working hours, seven days a week around the clock.

Since we offer this service worldwide, the support is provided in English. The service itself is free of charge, the only costs involved are the normal call charges.

9.5 Exchanging the electronics module

If the electronics module is defective, it can be replaced by the user.



In Ex applications, only instruments and electronics modules with appropriate Ex approval may be used.

If there is no electronics module available on site, the electronics module can be ordered through the agency serving you. The electronics modules are adapted to the respective sensor and differ in signal output or voltage supply.

The new electronics module must be loaded with the default settings of the sensor. These are the options:

- In the factory
- Or on site by the user

In both cases, the serial number of the sensor is needed. The serial numbers are stated on the type label of the instrument, on the inside of the housing as well as on the delivery note.

When loading on site, the order data must first be downloaded from the Internet (see operating instructions manual "*Electronics module*").



Caution:

All application-specific settings must be entered again. That's why you have to carry out a fresh setup after exchanging the electronics.

If you saved the parameter settings during the first setup of the sensor, you can transfer them to the replacement electronics module. A fresh setup is then not necessary.

9.6 Software update

The following components are required to update the instrument software:

- Instrument
- Voltage supply
- Interface adapter VEGACONNECT
- PC with PACTware
- Current instrument software as file

You can find the current instrument software as well as detailed information on the procedure in the download area of our homepage: www.vega.com.



Caution:

Instruments with approvals can be bound to certain software versions. Therefore make sure that the approval is still effective after a software update is carried out.

You can find detailed information in the download area at www.vega.com.

9.7 How to proceed if a repair is necessary

You can find an instrument return form as well as detailed information about the procedure in the download area of our homepage: www.vega.com.

By doing this you help us carry out the repair quickly and without having to call back for needed information.

If a repair is necessary, please proceed as follows:

- Print and fill out one form per instrument
- Clean the instrument and pack it damage-proof
- Attach the completed form and, if need be, also a safety data sheet outside on the packaging
- Please contact the agency serving you to get the address for the return shipment. You can find the agency on our home page www.vega.com.

10 Dismount

10.1 Dismounting steps

**Warning:**

Before dismounting, be aware of dangerous process conditions such as e.g. pressure in the vessel or pipeline, high temperatures, corrosive or toxic products etc.

Take note of chapters "*Mounting*" and "*Connecting to power supply*" and carry out the listed steps in reverse order.

10.2 Disposal

The instrument consists of materials which can be recycled by specialised recycling companies. We use recyclable materials and have designed the electronics to be easily separable.

Correct disposal avoids negative effects on humans and the environment and ensures recycling of useful raw materials.

Materials: see chapter "*Technical data*"

If you have no way to dispose of the old instrument properly, please contact us concerning return and disposal.

WEEE directive 2002/96/EG

This instrument is not subject to the WEEE directive 2002/96/EG and the respective national laws. Pass the instrument directly on to a specialised recycling company and do not use the municipal collecting points. These may be used only for privately used products according to the WEEE directive.

11 Supplement

11.1 Technical data

Note for approved instruments

The technical data in the respective safety instructions are valid for approved instruments (e.g. with Ex approval). These data can differ from the data listed herein, for example regarding the process conditions or the voltage supply.

Materials and weights

316L corresponds to 1.4404 or 1.4435

Materials, wetted parts with metal-jacketed lens antenna

- Process fitting 316L, Alloy C22 (2.4602), Alloy 400 (2.4360)
- Process seal On site
- Antenna PP, PEEK
- seal, antenna system FKM (SHS FPM 70C3 GLT), EPDM (COG AP310)

Materials, wetted parts with plastic horn antenna

- Adapter flange PP-GF30 black
- Seal, adapter flange FKM (COG VI500), EPDM (COG AP310)
- Antenna cone PBT-GF 30
- Focussing lense PP

Material, wetted parts rinsing air connection

- Rinsing air connection PP-GFK
- Seal FKM (COG VI500), EPDM (COG AP310)

Materials, non-wetted parts

- Compression flange PP-GF30 black
- Mounting strap 316L
- Fixing screws, mounting strap 316L
- Fixing screws, adapter flange 304
- Plastic housing plastic PBT (Polyester)
- Aluminium die-casting housing Aluminium die-casting AlSi10Mg, powder-coated - basis: Polyester
- Stainless steel housing 316L
- Cable gland PA, stainless steel, brass
- Sealing, cable gland NBR
- Blind plug, cable gland PA
- Seal between housing and housing lid Silicone SI 850 R, NBR silicone-free
- Inspection window in housing cover (optional) Polycarbonate
- Ground terminal 316L

Weights

- Instrument (depending on housing, process fitting and antenna) approx. 2 ... 17.2 kg (4.409 ... 37.92 lbs)

Torques

Max. torques, threaded version

- G $\frac{3}{4}$ 30 Nm (22.13 lbf ft)
- G $1\frac{1}{2}$ 200 Nm (147.5 lbf ft)

Max. torques, version plastic horn antenna

- Mounting screws, mounting strap on sensor housing 4 Nm (2.950 lbf ft)
- Flange screws, compression flange DN 80 5 Nm (3.689 lbf ft)
- Flange screws, adapter flange DN 100 7 Nm (5.163 lbf ft)

Max. torques, version metal-jacketed lens antenna

- Terminal screws for swivelling holder 8 Nm (5.9 lbf ft)

Max. torques for NPT cable glands and Conduit tubes

- Plastic housing 10 Nm (7.376 lbf ft)
- Aluminium/Stainless steel housing 50 Nm (36.88 lbf ft)

Input variable

Measured variable

The measured quantity is the distance between the end of the sensor antenna and the product surface. The reference plane for the measurement is the lower side of the flange.

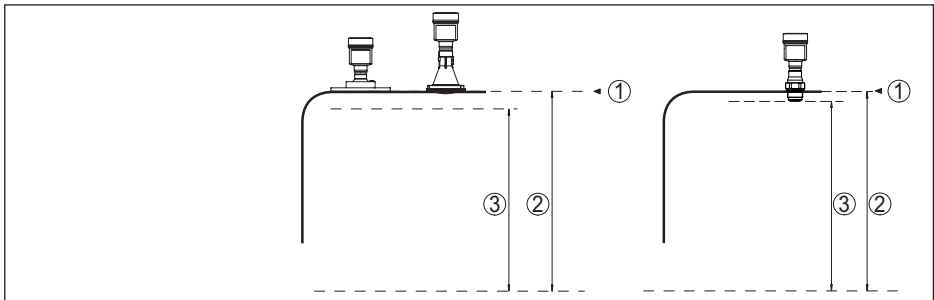

Fig. 57: Data of the input variable

- 1 Reference plane
- 2 Measured variable, max. measuring range
- 3 Useable measuring range (recommended min. distance see "Measuring accuracy")

Max. measuring range 120 m (393,7 ft)

Output variable

Output signal	4 ... 20 mA/HART
Range of the output signal	3.8 ... 20.5 mA/HART (default setting)
Signal resolution	0.3 μ A
Resolution, digital	< 1 mm (0.039 in)
Fault signal, current output (adjustable)	mA-value unchanged 20.5 mA, 22 mA, < 3.6 mA
Max. output current	22 mA

Starting current	≤ 3.6 mA; ≤ 10 mA for 5 ms after switching on
Load	see load diagram under Power supply
Damping (63 % of the input variable), adjustable	0 ... 999 s
HART output values according to HART 7.0 ²⁾	
– PV (Primary Value)	Lin. percent
– SV (Secondary Value)	Distance
– TV (Third Value)	Meas. certainty
– QV (Fourth Value)	Electronics temperature
Fulfilled HART specification	7.0
Further information on Manufacturer ID, Device ID, Device Revision	See website of HART Communication Foundation

Output variable - Additional current output

Output signal	4 ... 20 mA
Range of the output signal	3.8 ... 20.5 mA (default setting)
Signal resolution	0.3 µA
Failure signal current output (adjustable)	mA-value unchanged 20.5 mA, 22 mA, < 3.6 mA
Max. output current	22 mA
Starting current	≤ 3.6 mA; ≤ 10 mA for 5 ms after switching on
Load	see load diagram under Power supply
Damping (63 % of the input variable), adjustable	0 ... 999 s

Accuracy (according to DIN EN 60770-1)

Process reference conditions according to DIN EN 61298-1	
– Temperature	+18 ... +30 °C (+64 ... +86 °F)
– Relative humidity	45 ... 75 %
– Air pressure	860 ... 1060 mbar/86 ... 106 kPa (12.5 ... 15.4 psig)
Installation reference conditions	
– Min. distance to internal installations	> 200 mm (7.874 in)
– Reflector	Flat plate reflector, surface 1 x 1 m (3.281 x 3.281 ft)
– False reflections	Biggest false signal, 20 dB smaller than the useful signal
Deviation	See following diagrams

²⁾ Default values can be assigned individually.

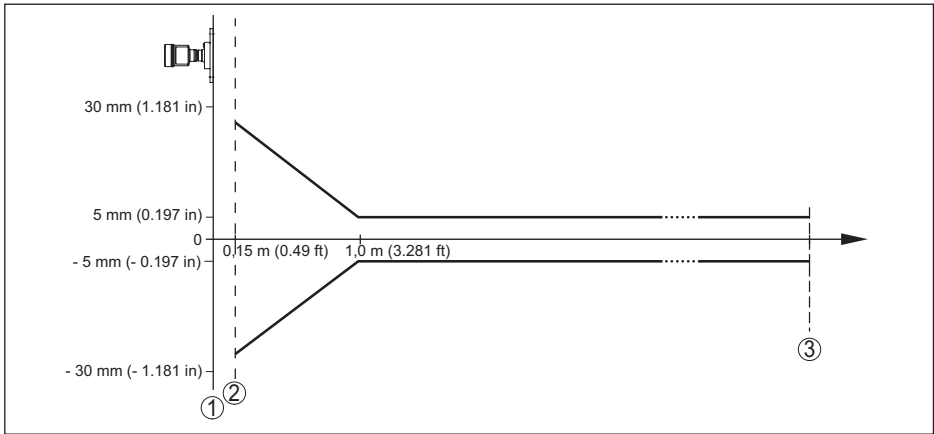

Fig. 58: Deviation under reference conditions

- 1 Reference plane
- 2 Recommended min. distance
- 3 Measuring range end

Repeatability	≤ ±1 mm
Deviation with bulk solids	The values depend to a great extent on the application. Binding specifications are thus not possible.

Variables influencing measurement accuracy

Specifications apply to the digital measured value

Temperature drift - Digital output ±3 mm/10 K, max. 10 mm

Specifications apply also to the current output

Temperature drift - Current output ±0.03 %/10 K relating to the 16 mA span max. ±0.3 %

Deviation on the current output through analogue/digital conversion

- Non-Ex and Ex-ia version < ±15 µA
- Ex-d-ia version < ±40 µA

Characteristics and performance data

Measuring frequency	W-band (within 75 - 85 GHz)
Measuring cycle time approx.	700 ms
Step response time ³⁾	≤ 3 s
Beam angle ⁴⁾	
- Plastic horn antenna	3.5°
- Metal-jacketed lens antenna	4°

³⁾ Time span (after a sudden measuring distance change of max. 2 m in bulk solids applications) until the output signal has taken on 90 % of the final value for the first time (IEC 61298-2).
⁴⁾ Outside the specified beam angle, the energy level of the radar signal is 50% (-3 dB) less.

Emitted HF power (depending on the parameter adjustment)⁵⁾

- Average spectral transmission power density -3 dBm/MHz EIRP
- Max. spectral transmission power density +34 dBm/50 MHz EIRP
- Max. power density at a distance of 1 m < 3 μW/cm²

Ambient conditions

Ambient, storage and transport temperature -40 ... +80 °C (-40 ... +176 °F)

Process conditions

For the process conditions, please also note the specifications on the type label. The lowest value always applies.

Process temperature

Antenna lens	Seal	Process temperature (measured on the process fitting)
PEEK	FKM (SHS FPM 70C3 GLT)	-40 ... +130 °C (-40 ... +266 °F)
		-40 ... +200 °C (-40 ... +392 °F)
	EPDM (COG AP302)	-40 ... +130 °C (-40 ... +266 °F)
PP	FKM (SHS FPM 70C3 GLT)	-40 ... +80 °C (-40 ... +176 °F)
	EPDM (COG AP310)	-40 ... +80 °C (-40 ... +176 °F)

Ambient temperature - Process temperature

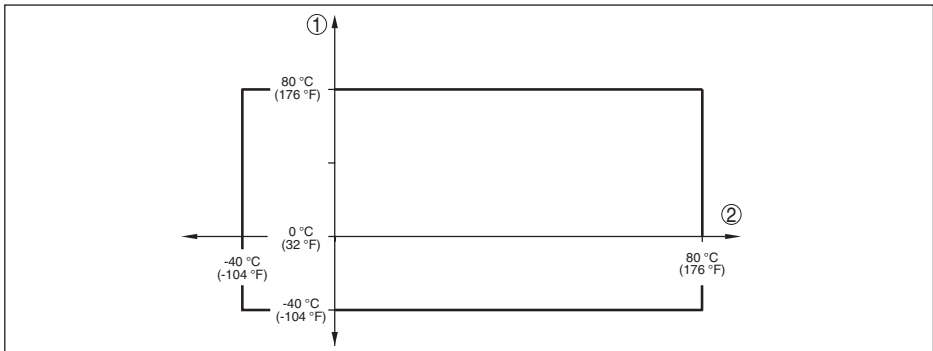

Fig. 59: Ambient temperature - Process temperature, plastic horn antenna

- 1 Ambient temperature
- 2 Process temperature

⁵⁾ EIRP: Equivalent Isotropic Radiated Power.

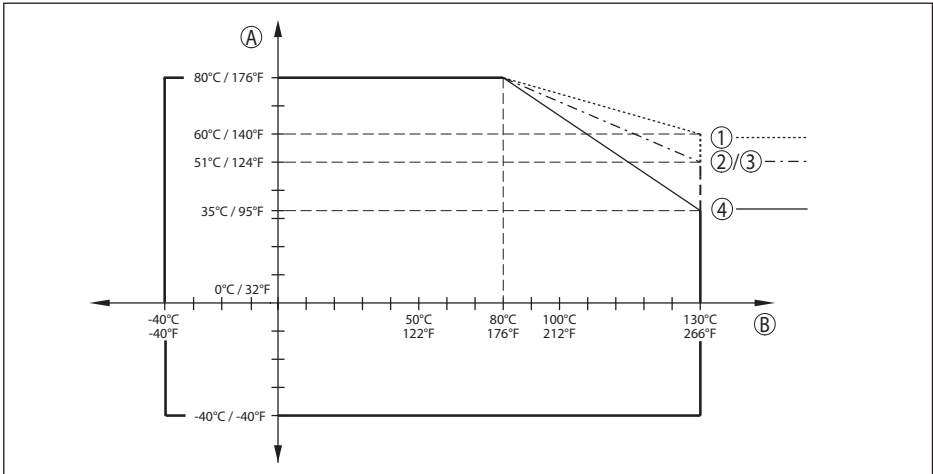

Fig. 60: Ambient temperature - Process temperature, metal-jacketed lens antenna up to +130 °C (266 °F)

- A Ambient temperature
- B Process temperature
- 1 Aluminium housing
- 2 Plastic housing
- 3 Stainless steel housing, precision casting
- 4 Stainless steel housing, electropolished

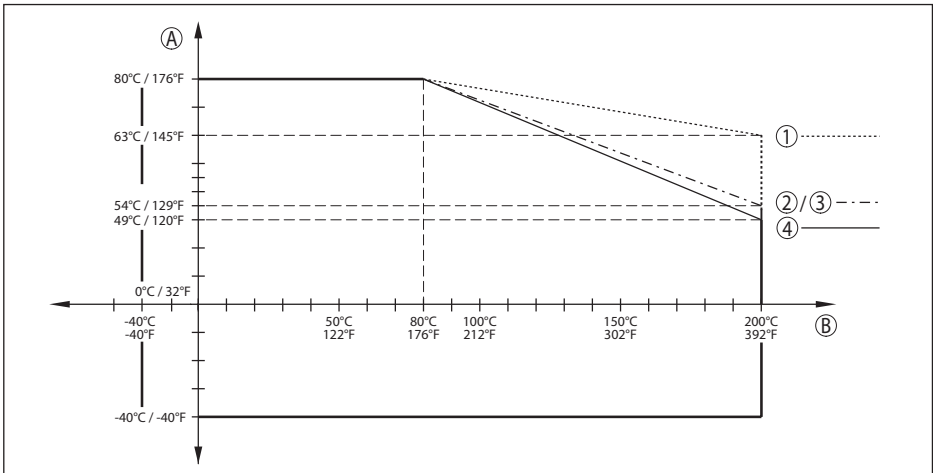

Fig. 61: Ambient temperature - Process temperature, metal-jacketed lens antenna up to +200 °C (392 °F)

- A Ambient temperature
- B Process temperature
- 1 Aluminium housing
- 2 Plastic housing
- 3 Stainless steel housing, precision casting
- 4 Stainless steel housing, electropolished

Vessel pressure

47247-EN-170315

Vessel pressure

- Metal-jacketed lens antenna -1 ... 3 bar (-100 ... 300 kPa/-14.5 ... 43.5 psig)
- Plastic horn antenna -1 ... 2 bar (-100 ... 200 kPa/-14.5 ... 29.1 psig)
- Plastic horn antenna - Version with adapter flange from DN 100 PP or PP-GF 30 -1 ... 1 bar (-100 ... 100 kPa/-14.5 ... 14.5 psig)

Vessel pressure relating to the flange nominal pressure stage

see supplementary instructions manual "*Flanges according to DIN-EN-ASME-JIS*"

Mechanical stresses

Vibration resistance - Metal jacketed lens antenna 4 g at 5 ... 200 Hz according to EN 60068-2-6 (vibration with resonance)

Vibration resistance - Plastic horn antenna

- With adapter flange 2 g at 5 ... 200 Hz according to EN 60068-2-6 (vibration with resonance)
- with mounting strap 1 g at 5 ... 200 Hz according to EN 60068-2-6 (vibration with resonance)

Shock resistance

100 g, 6 ms according to EN 60068-2-27 (mechanical shock)

Data on rinsing air connection

Recommended max. pressure with continuous rinsing 1 bar (14.50 psig)

Max. permissible pressure 6 bar (87.02 psig)

Air quality Filtered

Air volume, depending on pressure

Metal-jacketed lens antenna Pressure	Air volume	
	Without reflux valve	With reflux valve
0.2 bar (2.9 psig)	1.7 m ³ /h	-
0.4 bar (5.8 psig)	2.5 m ³ /h	-
0.6 bar (8.7 psig)	2.9 m ³ /h	0.8 m ³ /h
0.8 bar (11.6 psig)	3.3 m ³ /h	1.5 m ³ /h
1 bar (14.5 psig)	3.6 m ³ /h	2 m ³ /h
1.2 bar (17.4 psig)	3.9 m ³ /h	2.3 m ³ /h
1.4 bar (20.3 psig)	4 m ³ /h	2.7 m ³ /h
1.6 bar (23.2 psig)	4.3 m ³ /h	3 m ³ /h
1.8 bar (20.3 psig)	4.5 m ³ /h	3.5 m ³ /h
2 bar (23.2 psig)	4.6 m ³ /h	4 m ³ /h

Plastic horn antenna Pressure	Air volume	
	Without reflux valve	With reflux valve
0.2 bar (2.9 psig)	3.3 m ³ /h	-
0.4 bar (5.8 psig)	5 m ³ /h	-

Plastic horn antenna	Air volume	
	Without reflux valve	With reflux valve
Pressure		
0.6 bar (8.7 psig)	6 m ³ /h	1 m ³ /h
0.8 bar (11.6 psig)	-	2.1 m ³ /h
1 bar (14.5 psig)	-	3 m ³ /h
1.2 bar (17.4 psig)	-	3.5 m ³ /h
1.4 bar (20.3 psig)	-	4.2 m ³ /h
1.6 bar (23.2 psig)	-	4.4 m ³ /h
1.8 bar (20.3 psig)	-	4.8 m ³ /h
2 bar (23.2 psig)	-	5.1 m ³ /h

Connection

- Thread G $\frac{1}{8}$
- Seal with metal jacketed lens antenna Threaded plug of 316Ti

Reflux valve - (optional, is absolutely necessary for Ex applications)

- Material 316Ti
- Thread G $\frac{1}{8}$
- Seal FKM (SHS FPM 70C3 GLT), EPDM (COG AP310)
- For connection G $\frac{1}{8}$
- Opening pressure 0.5 bar (7.25 psig)
- Nominal pressure stage PN 250

Electromechanical data - version IP 66/IP 67 and IP 66/IP 68; 0.2 bar

Options of the cable entry

- Cable entry M20 x 1.5, $\frac{1}{2}$ NPT
- Cable gland M20 x 1,5; $\frac{1}{2}$ NPT (cable \varnothing see below table)
- Blind plug M20 x 1.5; $\frac{1}{2}$ NPT
- Closing cap $\frac{1}{2}$ NPT

Material cable gland	Material seal insert	Cable diameter				
		4.5 ... 8.5 mm	5 ... 9 mm	6 ... 12 mm	7 ... 12 mm	10 ... 14 mm
PA	NBR	-	●	●	-	●
Brass, nickel-plated	NBR	●	●	●	-	-
Stainless steel	NBR	-	●	●	-	●

Wire cross-section (spring-loaded terminals)

- Massive wire, stranded wire 0.2 ... 2.5 mm² (AWG 24 ... 14)
- Stranded wire with end sleeve 0.2 ... 1.5 mm² (AWG 24 ... 16)

Electromechanical data - version IP 66/IP 68 (1 bar)

Options of the cable entry

- Cable gland with integrated connection cable M20 x 1.5 (cable: \varnothing 5 ... 9 mm)
- Cable entry $\frac{1}{2}$ NPT
- Blind plug M20 x 1.5; $\frac{1}{2}$ NPT

Connection cable

- Wire cross-section 0.5 mm² (AWG 20)
- Wire resistance < 0.036 Ω /m
- Tensile strength < 1200 N (270 lbf)
- Standard length 5 m (16.4 ft)
- Max. length 180 m (590.6 ft)
- Min. bending radius 25 mm (0.984 in) with 25 °C (77 °F)
- Diameter approx. 8 mm (0.315 in)
- Colour - Non-Ex version Black
- Colour - Ex-version Blue

Display and adjustment module

Display element Display with backlight

Measured value indication

- Number of digits 5
- Size of digits W x H = 7 x 13 mm

Adjustment elements 4 keys

Protection rating

- unassembled IP 20
- mounted in the housing without lid IP 40

Ambient temperature - Display and adjustment module -20 ... +70 °C (-4 ... +158 °F)

Materials

- Housing ABS
- Inspection window Polyester foil

Interface to the external display and adjustment unit

Data transmission Digital (I²C-Bus)

Connection cable Four-wire

Sensor version	Configuration, connection cable			
	Cable length	Standard cable	Special cable	Screened
4 ... 20 mA/HART	50 m	●	-	-
Profibus PA, Foundation Fieldbus	25 m	-	●	●

Integrated clock

Date format	Day.Month.Year
Time format	12 h/24 h
Time zone, factory setting	CET
Rate deviation max.	10.5 min/year

Additional output parameter - Electronics temperature

Output of the temperature values

- Analogue	Via the current output
- Digital	Via the digital output signal - depending on the electronics version
Range	-40 ... +85 °C (-40 ... +185 °F)
Resolution	< 0.1 K
Accuracy	±3 K

Voltage supply

Operating voltage U_B

- Non-Ex instrument	12 ... 35 V DC
- Ex-d instrument	12 ... 35 V DC
- Ex ia instrument	12 ... 30 V DC
- Ex-d-ia instrument	17 ... 35 V DC

Operating voltage U_B - illuminated display and adjustment module

- Non-Ex instrument	18 ... 35 V DC
- Ex-d instrument	18 ... 35 V DC
- Ex ia instrument	18 ... 30 V DC
- Ex-d-ia instrument	Due to the barrier, no lighting possible

Reverse voltage protection Integrated

Permissible residual ripple - Non-Ex, Ex-ia instrument

- for $12\text{ V} < U_B < 18\text{ V}$	$\leq 0.7 V_{\text{eff}}$ (16 ... 400 Hz)
- for $18\text{ V} < U_B < 35\text{ V}$	$\leq 1.0 V_{\text{eff}}$ (16 ... 400 Hz)

Permissible residual ripple - Ex-d-ia instrument

- for $18\text{ V} < U_B < 35\text{ V}$	$\leq 1 V_{\text{eff}}$ (16 ... 400 Hz)
-----------------------------------------	-----------------------------------------

Load resistor

- Calculation	$(U_B - U_{\text{min}})/0.022\text{ A}$
- Example - Non-Ex instrument with $U_B = 24\text{ V DC}$	$(24\text{ V} - 12\text{ V})/0.022\text{ A} = 545\ \Omega$

Electrical protective measures

Protection rating

Housing material	Version	IP-protection class	NEMA protection
Plastic	Single chamber	IP 66/IP 67	Type 4X
	Double chamber	IP 66/IP 67	Type 4X

Housing material	Version	IP-protection class	NEMA protection
Aluminium	Single chamber	IP 66/IP 68 (0.2 bar) IP 68 (1 bar)	Type 6P -
	Double chamber	IP 66/IP 68 (0.2 bar) IP 68 (1 bar)	Type 6P -
Stainless steel (electro-polished)	Single chamber	IP 66/IP 68 (0.2 bar)	Type 6P
Stainless steel (precision casting)	Single chamber	IP 66/IP 68 (0.2 bar) IP 68 (1 bar)	Type 6P -
	Double chamber	IP 66/IP 68 (0.2 bar) IP 68 (1 bar)	Type 6P -

Protection rating (IEC 61010-1) III

Approvals

Instruments with approvals can have different technical specifications depending on the version.

For that reason the associated approval documents of these instruments have to be carefully noted. They are part of the delivery or can be downloaded under www.vega.com via "VEGA Tools" and "Instrument search" as well as in the download area.

11.2 Radio astronomy stations

Certain restrictions on the use of VEGAPULS 69 outside closed vessels result from the radio license. You can find these restrictions in chapter "*Radio license for Europe*". Some of these restrictions have to do radio astronomy stations. The following table states the geographic positions of radio astronomy stations in Europe:

Country	Name of the Station	Geographic Latitude	Geographic Longitude
Finland	Metsähovi	60°13'04" N	24°23'37" E
France	Plateau de Bure	44°38'01" N	05°54'26" E
Germany	Effelsberg	50°31'32" N	06°53'00" E
Italy	Sardinia	39°29'50" N	09°14'40" E
Spain	Yebes	40°31'27" N	03°05'22" W
	Pico Veleta	37°03'58" N	03°23'34" W
Sweden	Onsala	57°23'45" N	11°55'35" E

11.3 Dimensions

The following dimensional drawings represent only an extract of all possible versions. Detailed dimensional drawings can be downloaded at www.vega.com/downloads under "*Drawings*".

Plastic housing

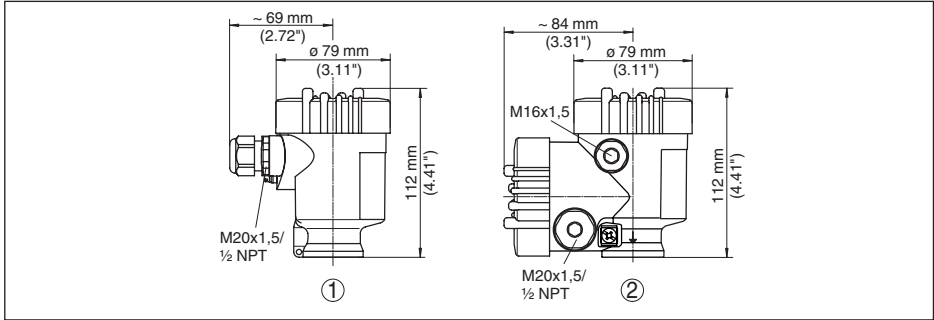

Fig. 62: Housing versions with protection rating IP 66/IP 67 - with integrated display and adjustment module the housing is 9 mm/0.35 in higher

- 1 Single chamber version
- 2 Double chamber version

Aluminium housing

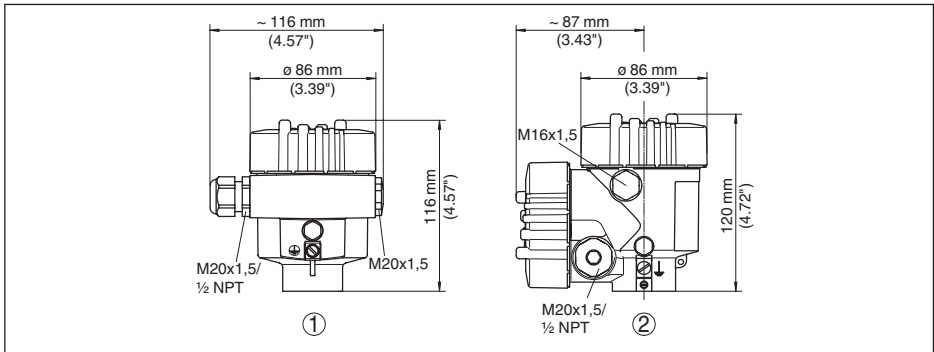

Fig. 63: Housing versions with protection rating IP 66/IP 68 (0.2 bar) - with integrated display and adjustment module the housing is 9 mm/0.35 in higher

- 1 Single chamber version
- 2 Double chamber version

Aluminium housing with protection rating IP 66/IP 68 (1 bar)

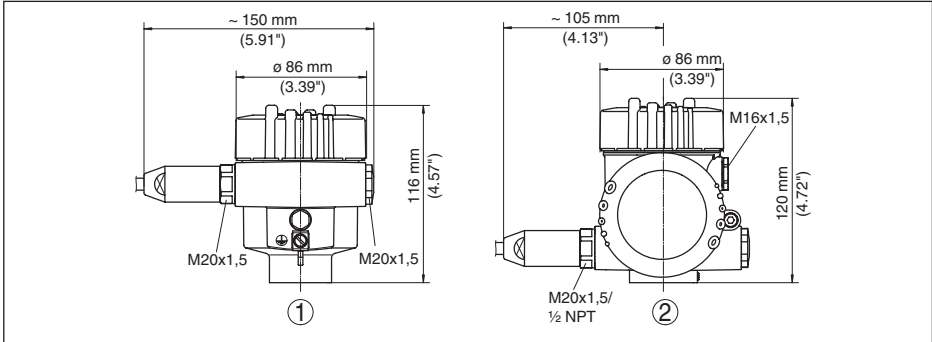

Fig. 64: Housing version with protection rating IP 66/IP 68 (1 bar) - with integrated display and adjustment module the housing is 9 mm/0.35 in higher

- 1 Single chamber version
- 2 Double chamber version

Stainless steel housing

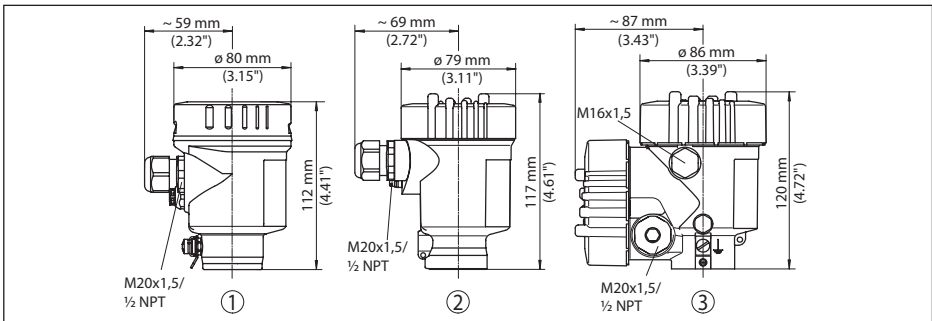

Fig. 65: Housing versions with protection rating IP 66/IP 68 (0.2 bar) - with integrated display and adjustment module the housing is 9 mm/0.35 in higher

- 1 Single chamber version, electropolished
- 2 Single chamber version, precision casting
- 3 Double chamber version, precision casting

Stainless steel housing with protection rating IP 66/IP 68, 1 bar

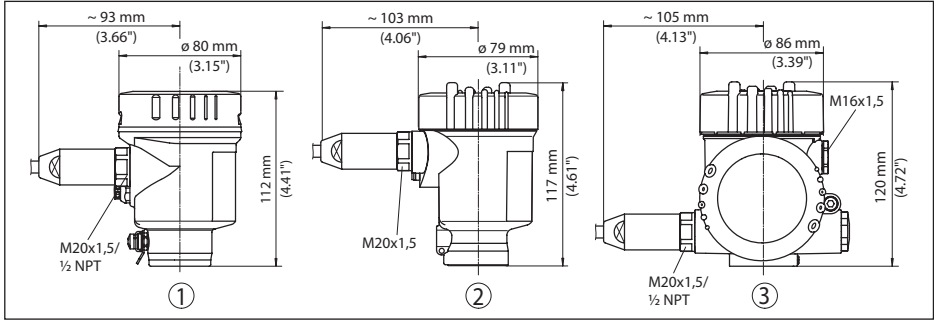

Fig. 66: Housing version with protection rating IP 66/IP 68 (1 bar) - with integrated display and adjustment module the housing is 9 mm/0.35 in higher

- 1 Single chamber version, electropolished
- 2 Single chamber version, precision casting
- 3 Double chamber version, precision casting

VEGAPULS 69, plastic horn antenna with compression flange

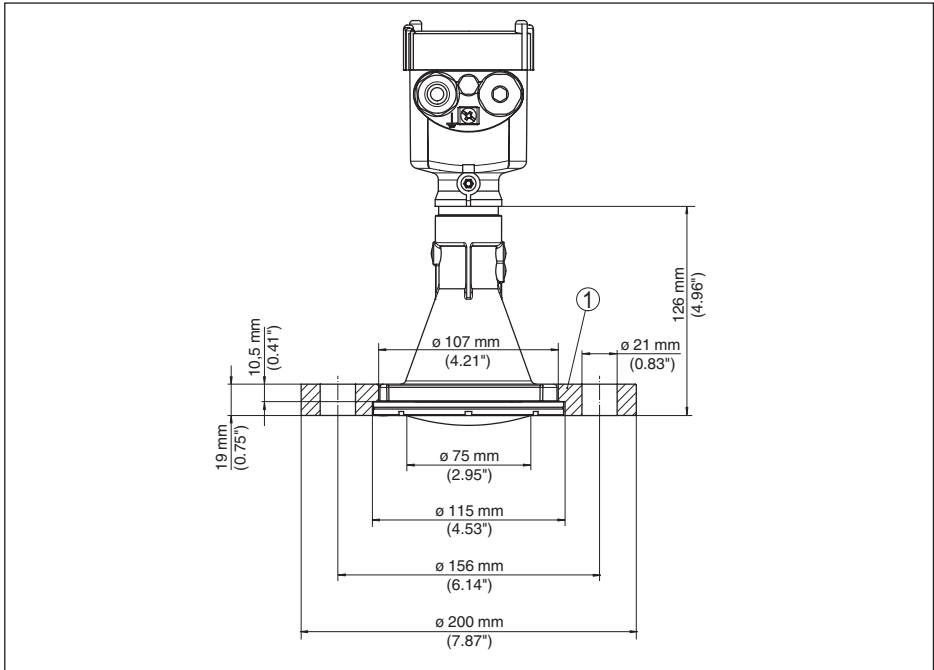

Fig. 67: Radar sensor with compression flange suitable for flanges 3" 150 lbs, DN 80 PN 16

- 1 Compression flange

VEGAPULS 69, plastic horn antenna with compression flange and rinsing connection

Fig. 68: Radar sensor with compression flange suitable for flanges 3" 150 lbs, DN 80 PN 16

- 1 Compression flange
- 2 Reflex valve
- 3 Rinsing connection

VEGAPULS 69, plastic horn antenna with adapter flange

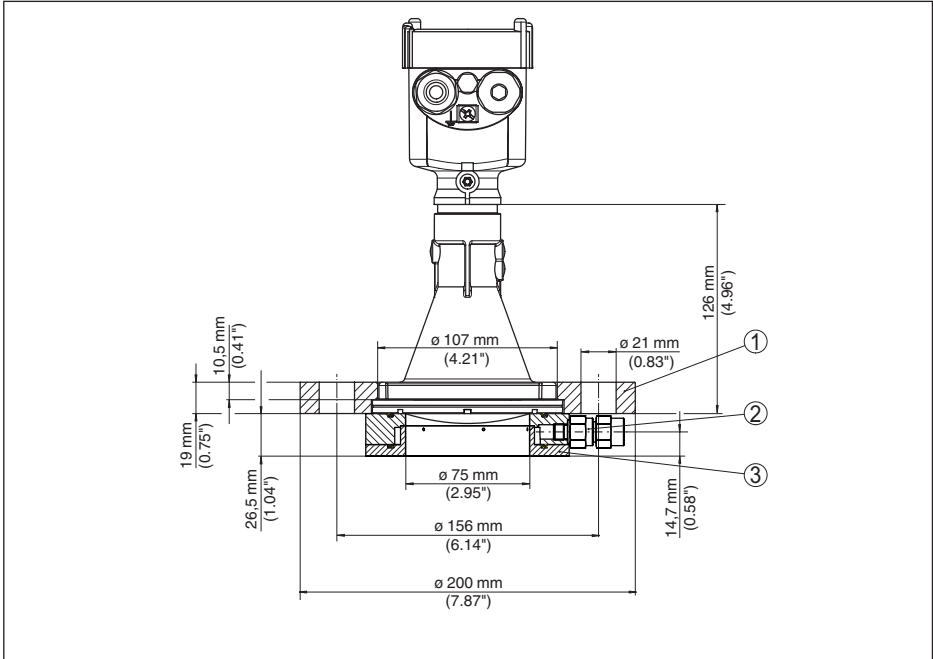
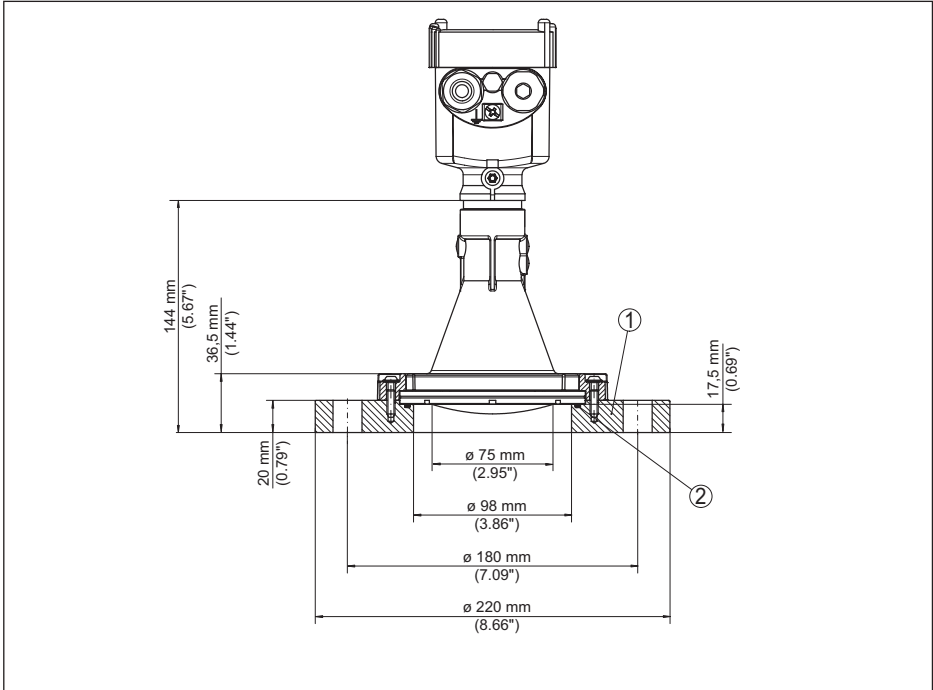

Fig. 69: Radar sensor with adapter flange DN 100 PN 6

- 1 Adapter flange
- 2 Process seal

VEGAPULS 69, plastic horn antenna mit adapter flange und rinsing connection

Fig. 70: VEGAPULS 69, adapter flange DN 100 PN 6 and rinsing connection

- 1 Rinsing air connection
- 2 Reflux valve
- 3 Adapter flange

VEGAPULS 69, plastic horn antenna with mounting strap

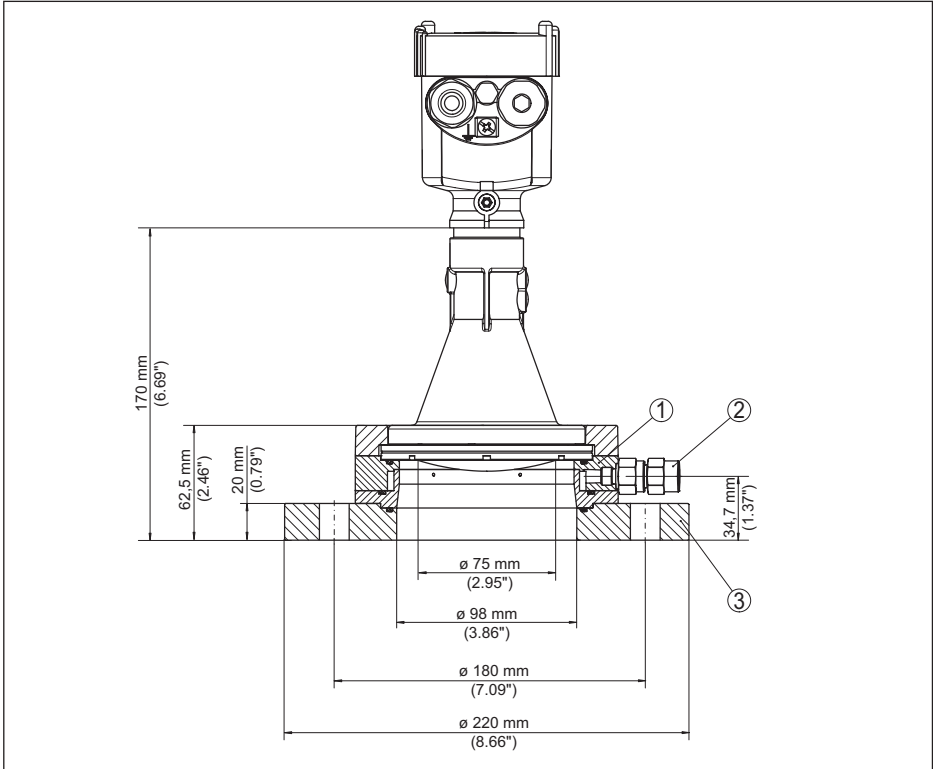
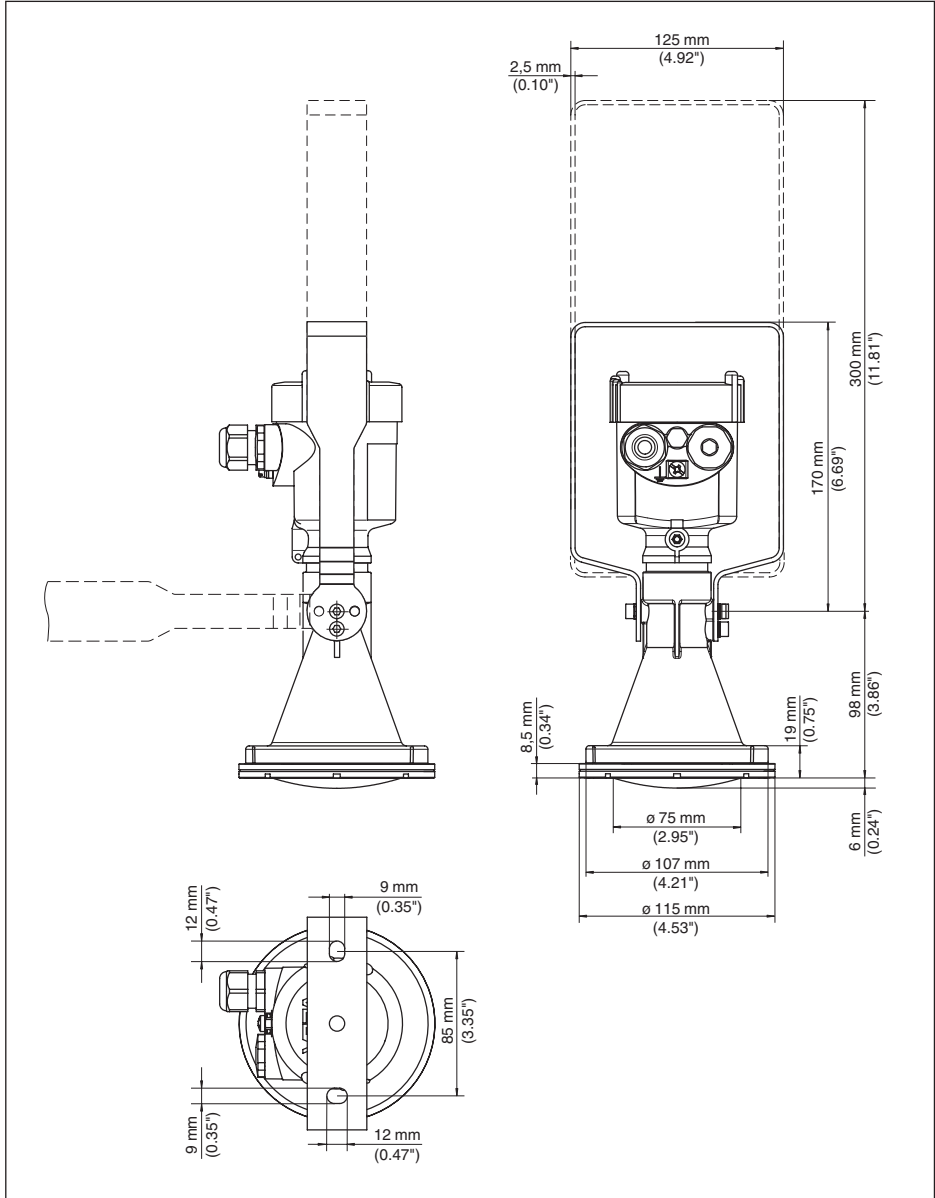

Fig. 71: VEGAPULS 69, plastic horn antenna, mounting strap in 170 or 300 mm length

VEGAPULS 69, metal-jacketed lens antenna

Fig. 72: VEGAPULS 69, metal-jacketed lens antenna. Flange thickness acc. to drawing, flange dimensions acc. to DIN/ASME/JIS.

- 1 Version up to 130 °C (266 °F)
- 2 Version up to 200 °C (392 °F)

VEGAPULS 69, metal-jacketed lens antenna with rinsing connection

Fig. 73: VEGAPULS 69, metal-jacketed lens antenna with rinsing connection

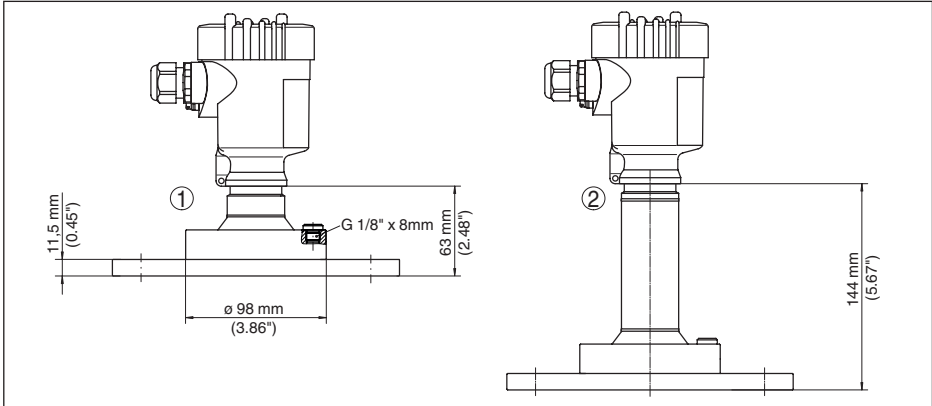
- 1 Version up to 130 °C (266 °F)
- 2 Version up to 200 °C (392 °F)
- 3 Blind plug
- 4 90° angle joint
- 5 Reflux valve

VEGAPULS 69, metal-jacketed lens antenna with swivelling holder

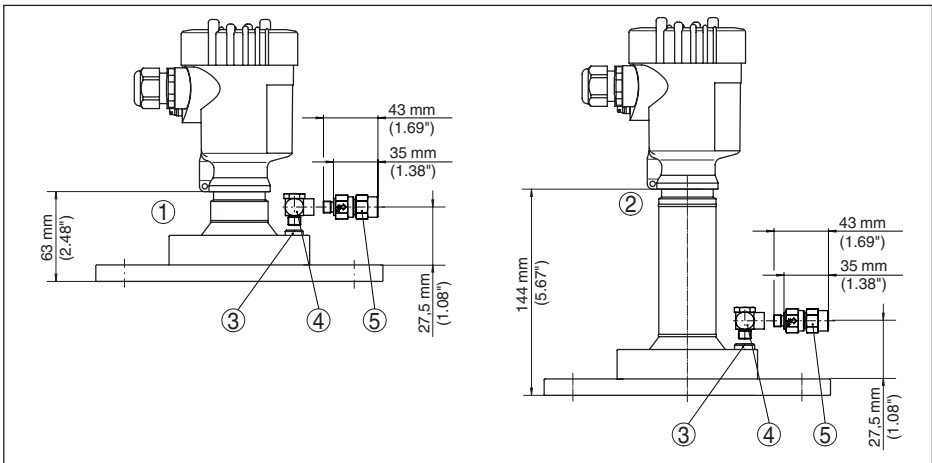
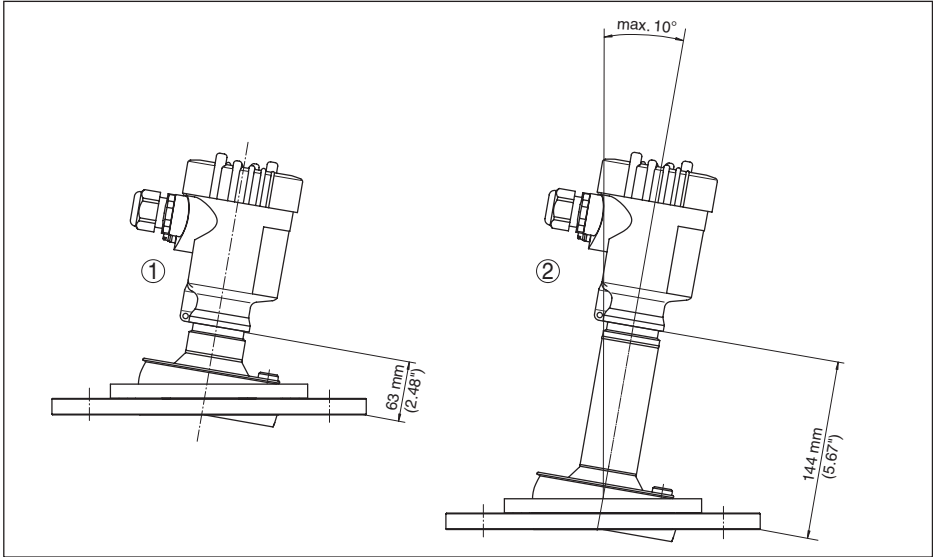

Fig. 74: VEGAPULS 69, metal-jacketed lens antenna and swivelling holder

- 1 Version up to 130 °C (266 °F)
- 2 Version up to 200 °C (392 °F)

VEGAPULS 69, metal-jacketed lens antenna with swivelling holder and rinsing connection

Fig. 75: VEGAPULS 69, metal-jacketed lens antenna with swivelling holder and rinsing connection

- 1 Version up to 130 °C (266 °F)
- 2 Version up to 200 °C (392 °F)
- 3 Blind plug
- 4 90° angle joint
- 5 Reflux valve

11.4 Industrial property rights

VEGA product lines are global protected by industrial property rights. Further information see www.vega.com.

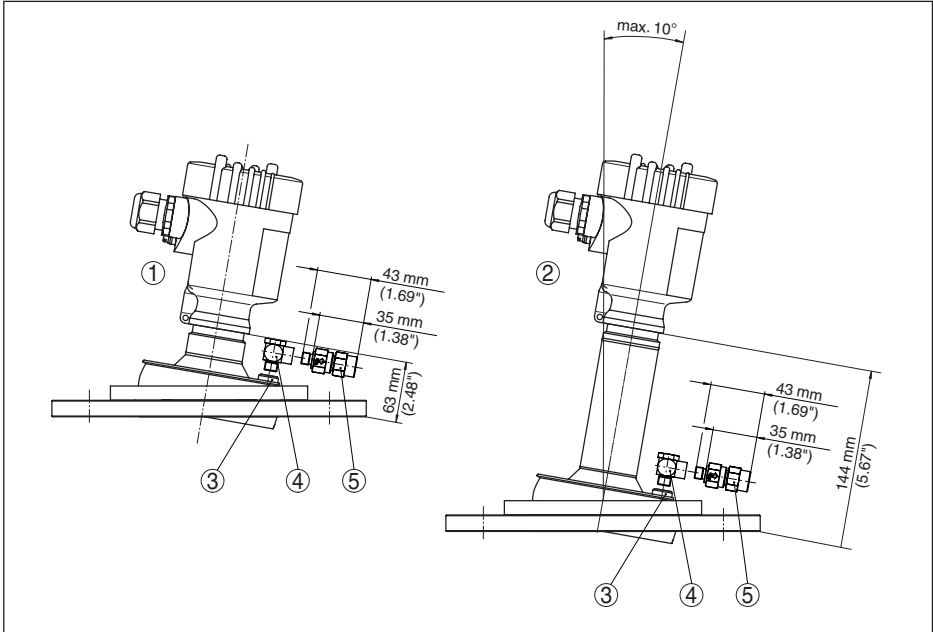
VEGA Produktfamilien sind weltweit geschützt durch gewerbliche Schutzrechte.

Nähere Informationen unter www.vega.com.

Les lignes de produits VEGA sont globalement protégées par des droits de propriété intellectuelle. Pour plus d'informations, on pourra se référer au site www.vega.com.

VEGA lineas de productos están protegidas por los derechos en el campo de la propiedad industrial. Para mayor información revise la pagina web www.vega.com.

Линии продукции фирмы ВЕГА защищаются по всему миру правами на интеллектуальную собственность. Дальнейшую информацию смотрите на сайте www.vega.com.

VEGA系列产品在全球享有知识产权保护。

进一步信息请参见网站www.vega.com。

11.5 Trademark

All the brands as well as trade and company names used are property of their lawful proprietor/originator.

INDEX**A**

Adjustment 43, 48, 49

C

Change the language 50

Check output signal 68

Connection

– Cable 31

Copy sensor settings 54

Current output

– Adjust 55

– Min./Max. 50

– Mode 49

Curve indication

– Echo curve 51

D

Damping 49

Date/Time 53

Default values 53

Deviation 69

Display lighting 51

E

Echo curve

– Setup 52

EDD (Enhanced Device Description) 63

Electrical connection 32

Electronics and terminal compartment 34

Error codes 67

Event memory 64

F

False signal suppression 55

Fault rectification 68

Functional principle 12

G

Grounding 32

H

HART 60

– Address 57

L

Linearisation 57

M

Main menu 44

Measured value memory 64

Measurement loop name 45

Mounting

– Flange 18

– Strap 17

Mounting socket 22

N

NAMUR NE 107 65, 66, 67

P

Peak value indicator 51

Polarisation 20

R

Repair 72

Reset 53

S

Sensor status 51

Service hotline 71

Set display parameters 51

Simulation 52

Special parameters 57

T

Type label 11

V

Vessel installations 26

Vessel insulation 27

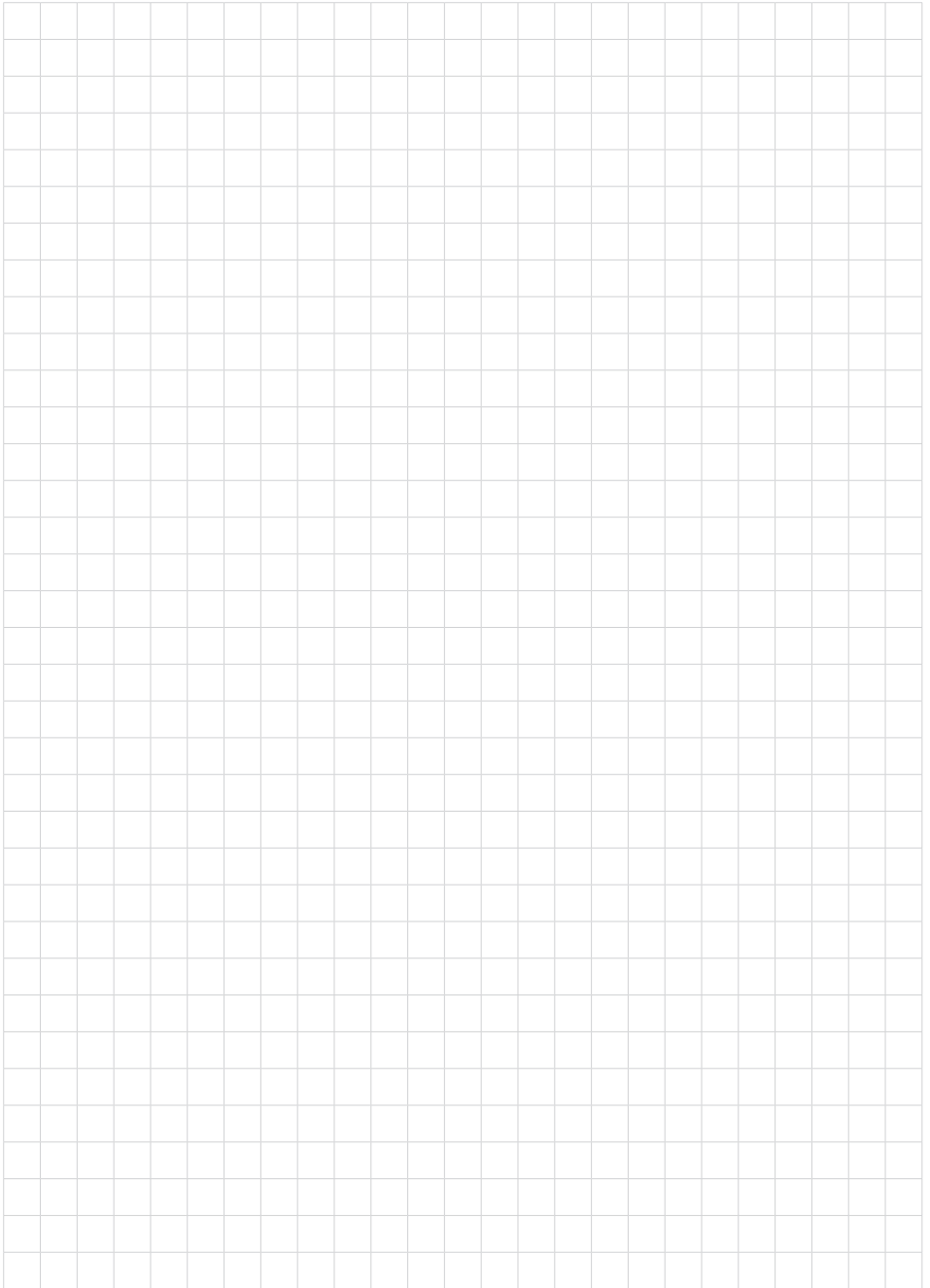



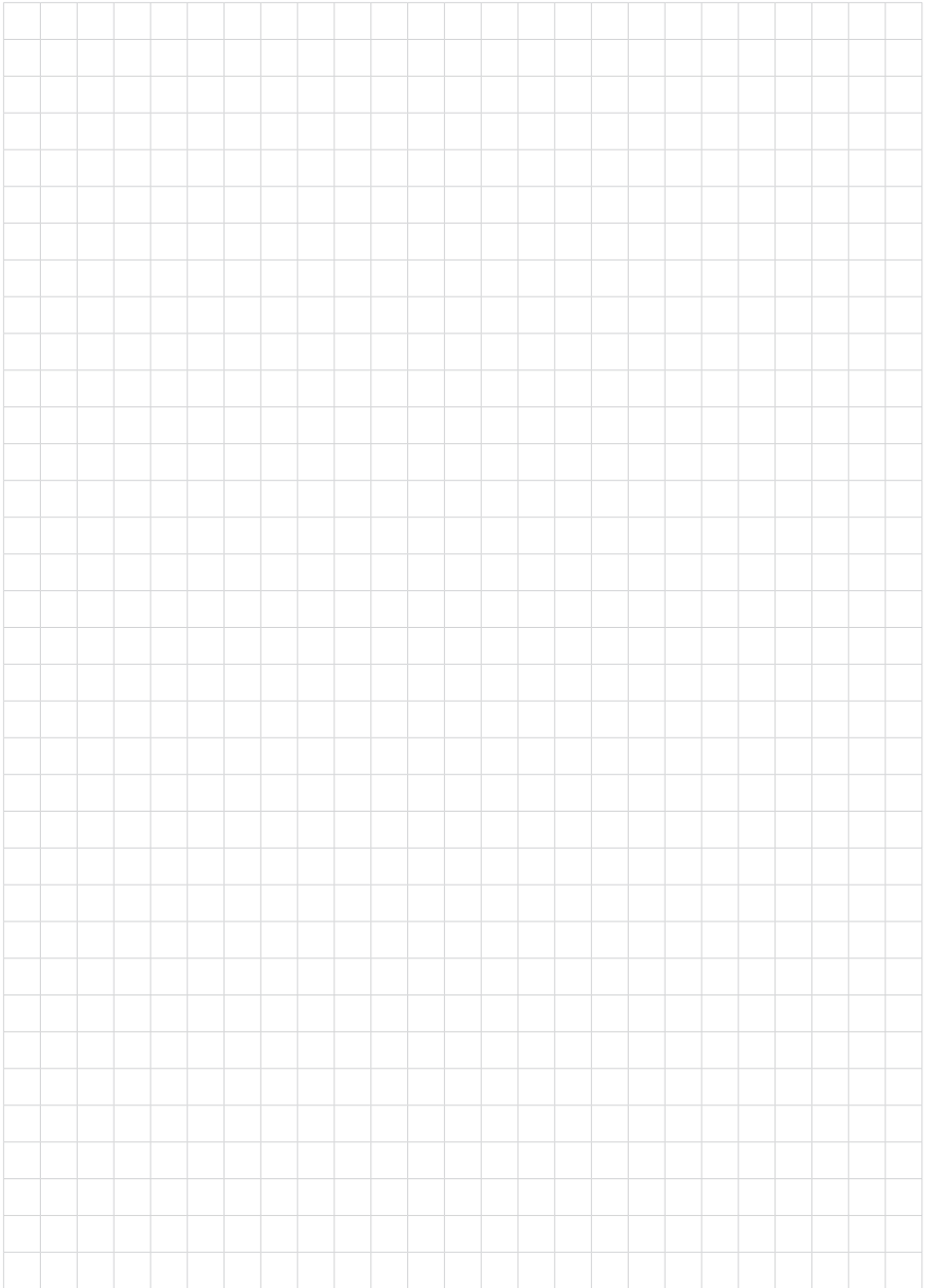

Printing date:

VEGA

All statements concerning scope of delivery, application, practical use and operating conditions of the sensors and processing systems correspond to the information available at the time of printing.

Subject to change without prior notice

© VEGA Grieshaber KG, Schiltach/Germany 2017



47247-EN-170315

VEGA Grieshaber KG
Am Hohenstein 113
77761 Schiltach
Germany

Phone +49 7836 50-0
Fax +49 7836 50-201
E-mail: info.de@vega.com
www.vega.com