

VOXOA Wireless In-Ear Stereo Sports Earphones
Bluetooth 4.0, NFC, aptX
User's manual (model VXE780)

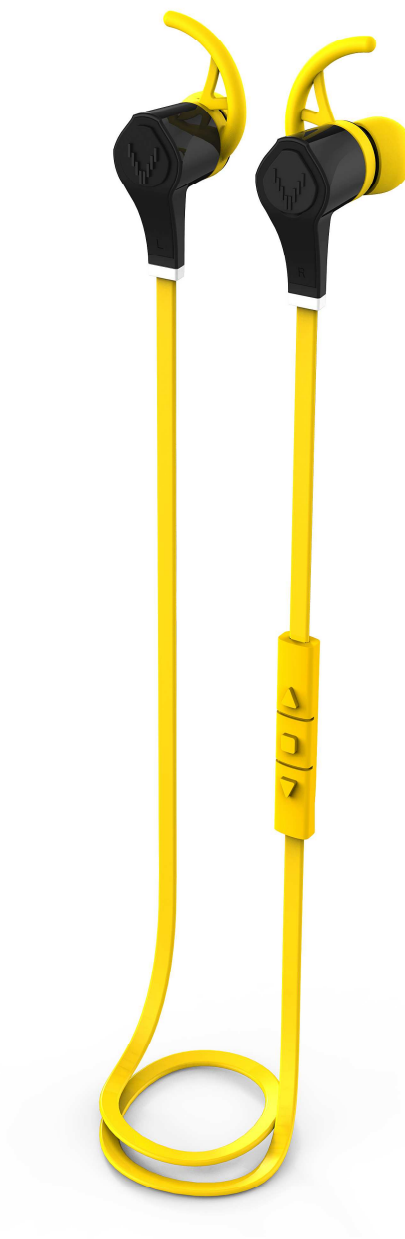

Contents

■ Brief introduction	1
■ Before use	1
1. Overview	1
2. Charging the earphones	2
■ Getting started	3
1. Turning on/off the earphones	3
2. Wearing the earphones	3
3. Pairing/connecting	4
1) Pairing earphones with Bluetooth mobile device via Bluetooth ...	4
2) Pairing earphones with Bluetooth mobile device via NFC	5
3) Pairing earphones with multi devices via Bluetooth	6
4. Making a call with the earphones	6
5. Playing music	9
6. LED indicator	10
7. Factory Reset	10
■ Care and maintenance	11
■ FAQs	11
■ Specification	12

Thank you for purchasing VOXOA Wireless In-Ear Stereo Sports Earphones (VXE780). Please read this user's manual carefully before use. Enjoy, share and repeat.

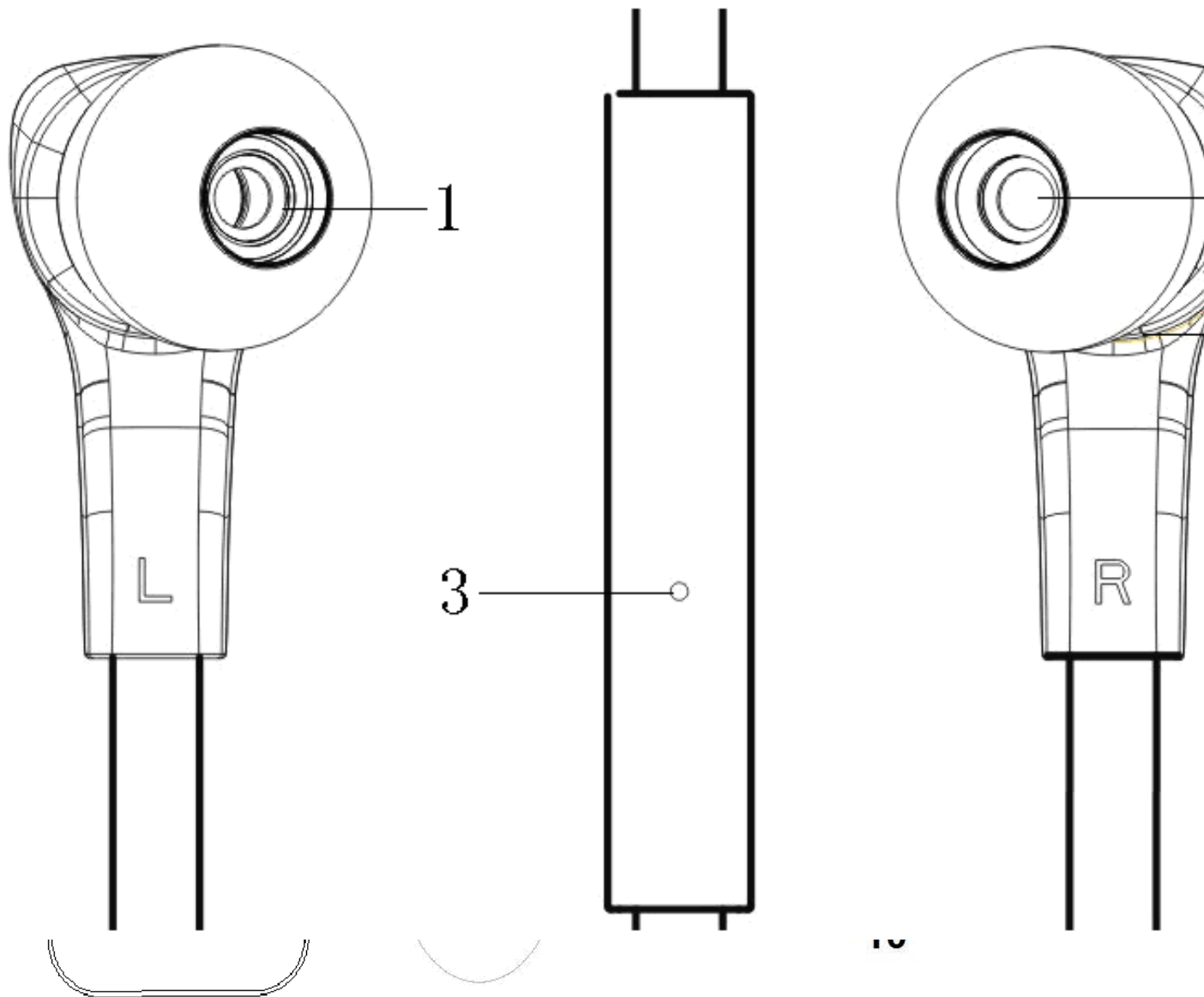

1	Cover of charging jack	6	NFC area
2	Micro USB charging jack	7	LED indicator
3	▲ :volume up/previous song	8	Microphone
4	■ : Multi-functions button	9	Big/middle/small eartips
5	▼: volume down/next song	10	Stabilizer

2. Charging for earphones

The earphones come with a built-in rechargeable battery, it is recommended to charge the battery fully for the first time.

When the earphones are low in power, the earphones emit prompt tones every 5 minutes and the red LED flashes. It is time to recharge the battery of the earphones.

The way of charging as following:

Using USB cable

1. Open the cover of the charging jack (the right earphone), and plug the USB charging cable, stop when you can't push any further (don't force it).
2. Plug another side of cable to the USB port of PC/Mac/USB charger.
Red light on: Charging. Red light off: Finish charging.
3. It takes about 2 hours to finish charging.

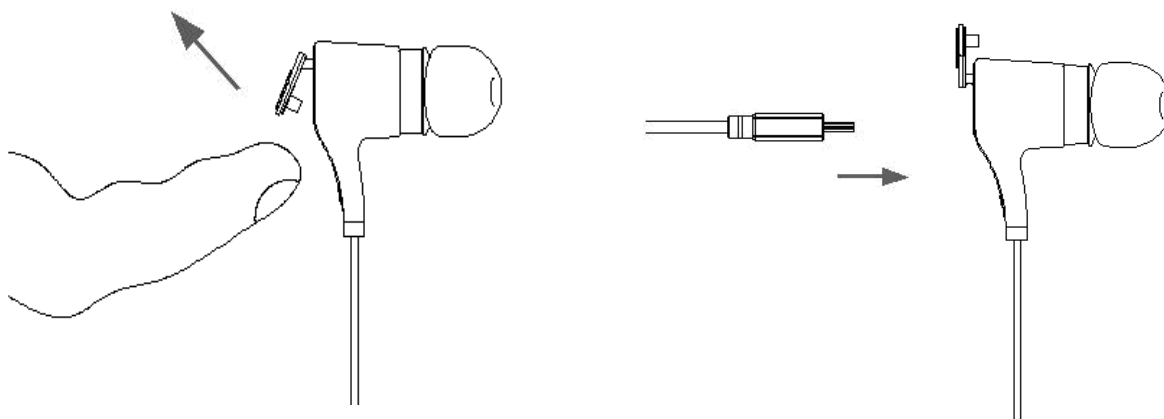



Remarks:

- 1) The battery is recyclable.
- 2) Batteries (battery pack or batteries installed) shall not be exposed to excessive heat place, such as sunshine, fire or the like.

■ Getting started

1. Turning on/off the earphones

Functions	Operation	Prompt tone
Turning on	Press and hold  about 4 seconds until blue LED flashes	Four rising tones
Turning off	Press and hold  about 4 seconds until red LED flashes	Four fall tones

Remark: To save power, the earphones will turn off automatically if they are not connected to a Bluetooth device for more than 5 minutes.

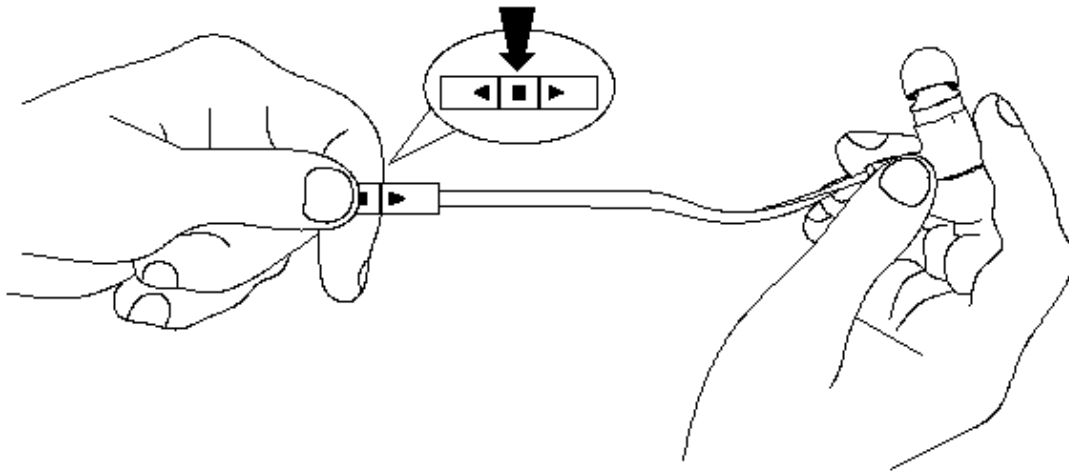

2. Wearing the earphones

a. Put the stabilizer into the earphones and rotate to the suitable position as shown below:

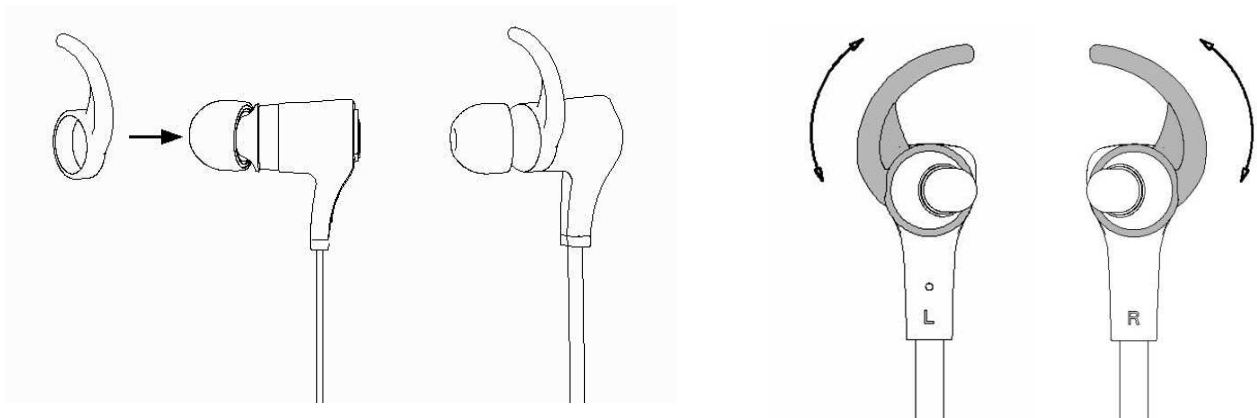

b. Choose suitable size eartips according to your ear and wear as following shown:



c. Set up the cord management clips to get better wearing as following shown:

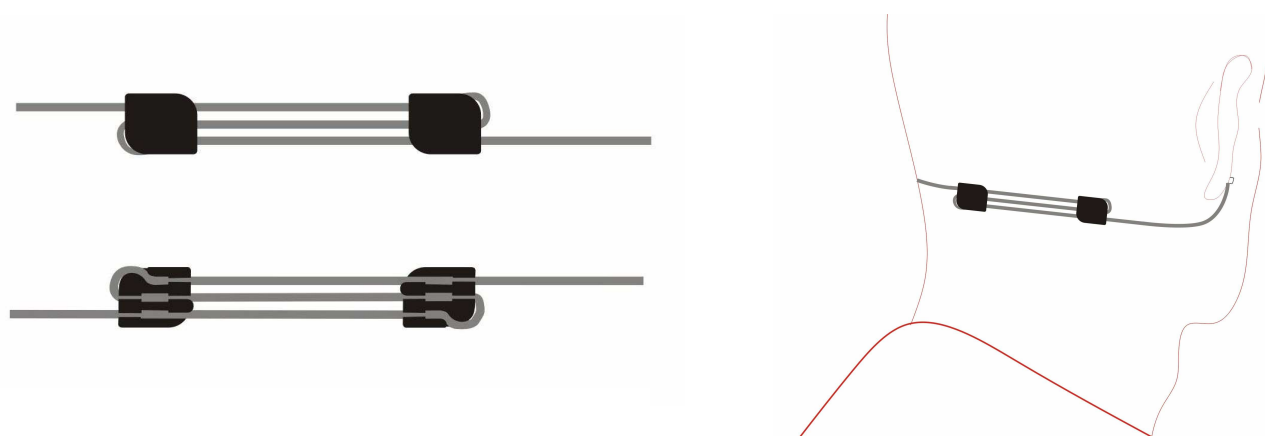

3. Pairing/connecting

1) Pairing earphones with Bluetooth mobile device via Bluetooth

Prior to using the earphones for the first time, you have to pair it with a Bluetooth-enabled mobile device. The pairing procedures are subject to different models of mobile devices. Please refer to your mobile device user's manual for further information.

The general pairing procedures are as follows:

- 1) Keep your earphones turned off and within 1 meter of mobile device;
- 2) Press and hold  about 8 seconds until the red and blue LED flash alternately, the earphones enter into pairing mode;

- 3) Activate your mobile device's Bluetooth function and search for Bluetooth devices within range, select "VOXOA Earphone 78X" from the list of devices shown (enter password "0000" if the earphones prompt);
- 4) After successful connecting, blue LED of earphones flashes twice every 4 seconds

Remarks:

- ◆ Pairing mode will last 2 minutes, the earphones will back to standby mode if the pairing failure.
- ◆ If the pairing is not successful, turn off the earphones and repeat the steps as above.
- ◆ Every time the earphones is turned on, it will connect to last connected device automatically. The earphones can remember 8 previously paired devices, when the number of paired devices exceeds 8, the first one will be replaced.

2) Pairing earphones with a Bluetooth mobile device via NFC

VXE780 support NFC technology, it can quickly connect with Bluetooth mobile device via NFC.

The general pairing procedures are as follows:

- 1) Please activate the Bluetooth and NFC function of mobile device;
- 2) Pairing and connecting with mobile device. Please refer to following pictures:



Remarks:

- Please keep the NFC area of mobile device and earphones within 1 centimeter until the red and blue LED of earphones flash alternately (It may take 3 seconds to make the first pairing).
- The earphones will disconnect when the NFC area of mobile device and earphones touch each other again.





3) Pairing earphones with multi devices via Bluetooth

The earphones can connect with two Bluetooth mobile devices at the same time.

The general pairing procedures are as follows:



- 1) Pairing the earphones with device one
- 2) Turn on the earphones to enter into pairing mode again, and pairing them with device two
- 3) Operate device one to connect with earphones. The earphones have already connected with two devices in this moment











Remarks:

- The multi-pair function is off in factory set, please turn on this function as following:
Turn on: long press  and  button under standby mode, and release it until you hear four rising tones
Turn off: long press  and  button under standby mode, and release it until you hear four fall tones
- To improve the stabilization of earphones, we suggest you turn off the multi-pair function when you only connect with one mobile device.

4. Making a call with the earphones

1) Basic operation

Functions	Status of earphones	Operation	Prompt tone
Cancel a call	Calling	Short press  once	One short tone
Answer a call	Incoming call ringing	Short press  once	Two rising tones

Reject a call	Incoming call ringing	Long press  about 2 seconds and release it until listen a tone	Two fall tones
End a call	During a call	Short press  once	One short tone
Volume up	During a call	Short press  button	
Volume down	During a call	Short press  button	
Transfer conversation to mobile phone	During a call	Long press  about 2 seconds	One short tone
Transfer conversation to earphones	During a call	Long press  about 2 seconds	One short tone
Microphone mute	During a call	Long press  about 2 seconds	Two fall tones
Cancel mute	During a call (microphone mute)	Long press  about 2 seconds	Two rising tones
Voice dial	Standby mode (connected device)	Short press  and  button simultaneously	One short tone
Redial the last number	Standby mode (connected device)	Double click  button	One short tone

Warning: Excessive pressure and/or long period of time from earphones and headphones can cause hearing loss. Use moderate volume on the earphones.

Note:

- ◆ Not all the mobile devices support all the functions listed above. Different function and prompt tone according to different mobile device. Please refer to your mobile device user's manual.
- ◆ When the volume is adjusted to max or min, you will hear one prompt tone.
- ◆ When the earphones under microphone mute mode, you will hear two tone continuously every 10 seconds.
- ◆ When pressing the answer button on some mobile devices, the call will be transferred to the mobile device. You can switch the call to the earphones by using the conversation switch button or through operating on the mobile device. Please refer to your mobile device user manual for further information.

2) Three-ways call operation

Functions	Status of earphones	Operation
Answer new call and end current call	There are second incoming call	Short press ■ once
Answer new call and retain current call	There are second incoming call	Double click ■ button
Switch calls	Keep conversation	Double click ■ button
End current call and switch retain call	Keep conversation	Short press ■ once

3) Connect with two mobile devices

Functions	Status of earphones	Operation
End phone call #1 and answer phone call #2	During phone call #1, phone 2 has incoming call	Short press ■ once
Retain phone call #1 and answer phone call #2	During phone call #1, phone 2 has incoming call	Double click ■ button
Switch call	During call, one of phone call is retained	Double click ■ button
End current call, back to retain phone call	During call, one of phone call is retained	Short press ■ once

5. Playing music

Functions	Status of the earphones	Operation
Volume up	Playing music	Short press ▲ button
Volume down	Playing music	Short press ▼ button
Last song	Playing music	Long press ▲ button
Next song	Playing music	Long press ▼ button
Pause	Playing music	Short press ■ once
play	Pausing	Short press ■ once

Notes:

- ◆ When the volume is adjusted to max or min., you will hear one prompt tone.
- ◆ If you want to remote control last/next song, pause/play, it needs your Bluetooth mobile device or Bluetooth transmitter paired with the earphones to support AVRCP profile, please refer to the user's manual of your mobile device or Bluetooth transmitter for further information.

6. LED indicator

LED indicator	Status of earphones
Red and blue LED flashes alternately	Pairing mode
Blue LED flashes once every 2 seconds	Not connected to device
Blue LED flashes twice every 4 seconds	Connected to device
Red LED flashes instead of blue LED	Low battery

7. Factory Reset

When you are charging the battery, long press ▲ button about 4 seconds and release it until the red and blue LED flashes simultaneously, you will hear 4 prompt tone. Your earphones' settings are reset to factory defaults.

Remarks:

During the factory reset, the paired list of earphones is deleted. After turning on again, the earphones will enter pairing mode automatically, and you need to re-pair and connect with Bluetooth devices.

■ Care and maintenance

Read the following recommendations carefully before using VXE780. Following these you will be able to enjoy this product for many years.

- ◆ Keep it dry and don't put it in the damp place to avoid the product's internal circuit being affected.
- ◆ After using this product during strenuous exercise, wipe it dry.
- ◆ Keep the product away from direct sunlight or hot places. High temperatures will shorten the life of electronic devices, destroy the battery or distort certain plastic parts.
- ◆ Don't expose the product to extremely cold areas. It may damage the internal circuit board.
- ◆ Don't try to disassemble the product as it may get damaged if you are not professional.
- ◆ Don't let it fall down onto the floor or other hard surfaces. The internal circuit might get damaged.
- ◆ Don't use intensive chemical products or detergent to clean the product.

- ◆ Don't scratch the surface with sharp things.

■ FAQs

1. What does it mean when red LED flashes instead of blue LED?

Battery is low in power, and needs to be recharged.

2. Why is the red LED off when charging?

- a) Please make sure the charging device connect with earphones Well;
- b) The battery may dry up. Please charge the battery for 30 minutes, and then the red LED will be ON.

3. Why can't my mobile device search and find the earphones?

Please make sure the earphones are in pairing mode and in the effective working range, and then the earphones can be paired and connected.

4. Why can't my mobile device pair with earphones via NFC?

- a) Make sure to activate NFC function of your mobile device
- b) Please keep the NFC chip of mobile device and earphones within 1 centimeter until the red and blue LED of earphones flash alternately (First pairing time maybe 3 seconds).

5. Why can't I hear the sound on the earphones?

- c) Make sure the earphones has been switched on;
- d) Make sure the volume is not too low or muted;
- e) Make sure the earphones connects with the mobile device correctly;
- f) Make sure the distance between the earphones and the mobile device is in the available Bluetooth range.

6. Why can't I hear the sound clearly on the earphones?

- a) Make sure the mobile device is in the strong signal area;
- b) Make sure the earphones is in the available range of this product.

7. Why the pause/play, last/next song not function when playing music?

Make sure your Bluetooth device supports AVRCP (Audio/Video Remote Control profile)

■ Specifications

Bluetooth version	Bluetooth V4.0
Bluetooth profiles	Earphones, Hands free, A2DP, AVRCP
Operating distance	10meters
Earphones music time	About 5 hours (at max volume), see note
Earphones talk time	About 5.5 hours
Standby time	About 200 hours
Earphones charging time	About 2 hours
Dimension	Earphones: 32x14.5x28 mm
Weight	About 13.5 g

Note: The battery will last longer when you set it at moderate volume.

Warning: Changes or modifications to this unit not expressly approved by the party responsible for compliance could void the user's authority to operate the equipment.

NOTE: This equipment has been tested and found to comply with the limits for a Class B digital device, pursuant to Part 15 of the FCC Rules. These limits are designed to provide reasonable protection against harmful interference in a residential installation. This equipment generates, uses and can radiate radio frequency energy and, if not installed and used in accordance with the instructions, may cause harmful interference to radio communications. However, there is no guarantee that interference will not occur in a particular installation. If this equipment does cause harmful interference to radio or television reception, which can be determined by turning the equipment off and on, the user is encouraged to try to correct the interference by one or more of the following measures:

Reorient or relocate the receiving antenna. Increase the separation between the equipment and receiver. Connect the equipment into an outlet on a circuit

different from that to which the receiver is connected.

Consult the dealer or an experienced radio/TV technician for help.

This device complies with Part 15 of the FCC Rules. Operation is subject to the following two conditions : (1) this device may not cause harmful interference, and (2) this device must accept any interference received including interference that may cause undesired operation.

lithium battery:

CAUTION

RISK OF EXPLOSION IF BATTERY IS REPLACED

BY AN INCORRECT TYPE

DISPOSE OF USED BATTERIES ACCORDING TO THE

INSTRUCTIONS

TO THE INSTRUCTIONS

Headset:

To prevent possible hearing damage, do not listen at high volume levels for long periods

