

Go to
businessphones.vtech.com
to register your product for
enhanced warranty support
and the latest VTech product
news.

VH6212

DECT 6.0
Cordless Headset
and Charger with
Dongle

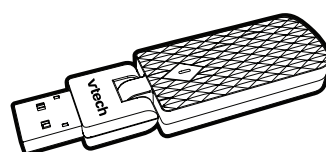
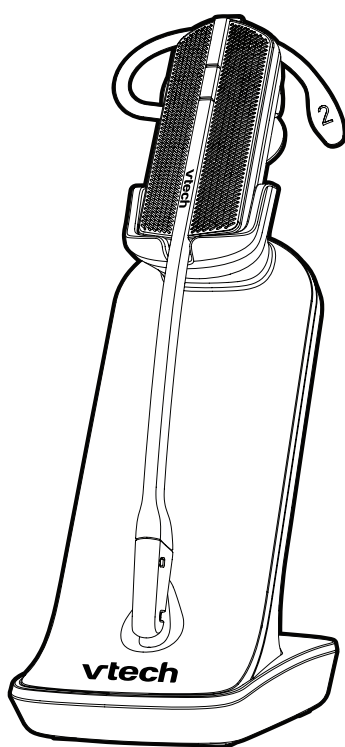

vtech[®]

User's manual

Congratulations

on your purchase of this VTech product. Before using this product, please read the **Important safety information**.

This user's manual provides you with the complete installation, setup and operation instructions.

For customer service or product information, visit our website at **businessphones.vtech.com** or call **1 (800) 595-9511**. In Canada, please dial **1 (800) 267-7377**.



Telephones identified with this logo have reduced noise and interference when used with most T-coil equipped hearing aids and cochlear implants. The TIA-1083 Compliant Logo is a trademark of the Telecommunications Industry Association. Used under license.

Introduction

The VH6212 includes a cordless headset, charger, and a Dongle. The Dongle functions as a headset base so that this product allows you to have handsfree phone conversations. You can connect your VH6212:

- **To computer** (pages 8-10). Use the Dongle of your headset to connect the headset and your PC. You can make and answer VoIP calls through Skype or Skype for Business, or landline calls using the **VTech Softphone Call Manager**. You can also use the voice command feature to make or answer calls after you have installed the **VTech Softphone Call Manager**.

Visit www.vtechphones.com/downloads to download **VTech Softphone Call Manager**. Unzip and install the file after download.

For installation and operation instructions of the software, refer to the **Installation and Operation Guide**.

Parts checklist

Your product package contains the following items. Save your sales receipt and original packaging in the event warranty service is necessary.



User's manual

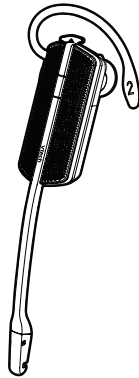

Cordless headset with earbud attached

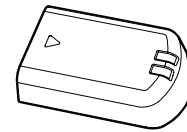

Battery with battery compartment cover attached

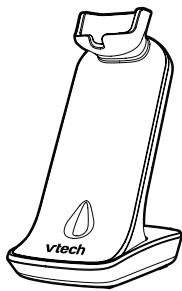

Headset charger



Headset charger power adapter

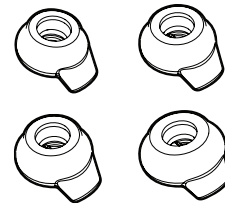

Four earbuds

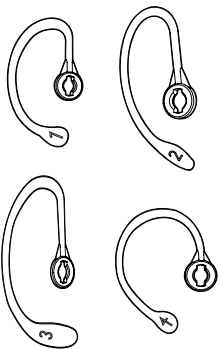

Four over-the-ear hooks



Over the head band

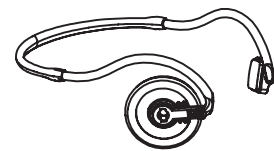

Behind-the-neck band



Dongle

Table of contents

Getting started

Headset overview	1
Headset lights	1
Headset alert tones	3
Headset charger overview	4
Dongle overview	5
Dongle lights	5
Battery installation	6
Headset charger installation and battery charging	7
Connect the Dongle to a computer	8
Connect the Dongle of your headset to a computer	8
Position the headset	11
Over-the-ear hook	11
Over the head band	14
Behind-the-neck band	16

Operation

Headset operation	18
Before use	18
Power on/off the headset	18
Answer a call	18
End a call	18
Voice command	19
Headset ringer	19
Caller ID announce	19
Temporary ringer silencing	19
Options while on calls	20
Volume control	20
Mute	20

Appendix

Registering Headset to Dongle	21
Register your Headset to the Dongle	21
Deregistering headset	22
Deregister all headsets from your Dongle	22
Troubleshooting	23
Maintenance	29
Important safety information ...	30
Safety information	30
Especially about cordless headsets	31
Precautions for users of implanted cardiac pacemakers	32
For C-UL compliance	33
Mesures de sécurité importantes	33
FCC Part 15	37
California Energy Commission battery charging testing instructions	39
Limited warranty	40
Technical specifications	43

Getting started

Headset overview

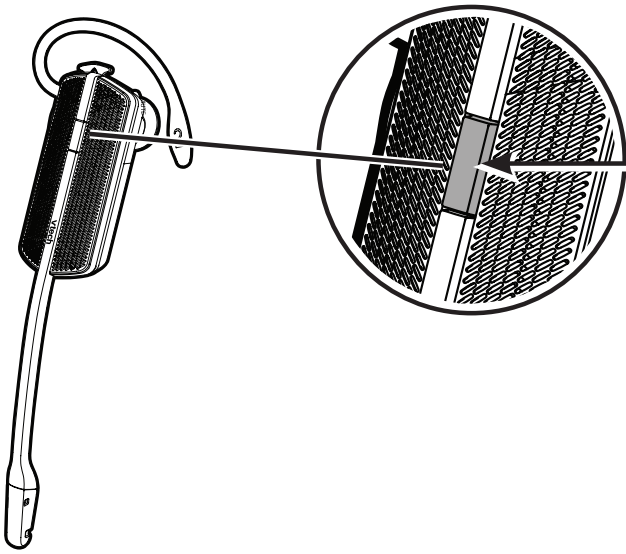

ON/OFF button and LED light

Press to make, answer or end a call.

Headset lights

LED light status	
Red	<ul style="list-style-type: none">• Steady red when the headset battery is low and the headset is charging in the headset base.• Flashes every 10 seconds to indicate the battery is low when the headset is not in the headset base.• Flashes three times to indicate the headset is powering off.
Blue	<ul style="list-style-type: none">• Steady blue when the headset battery is fully charged.• Flashes three times to indicate the headset is powering on.• Flashes twice every three seconds when the headset is in use.• Flashes four times every four seconds when there is an incoming call in PHONE mode.• Flashes every 10 seconds when a registered headset in idle mode is out of the headset base.
Purple	<ul style="list-style-type: none">• Steady purple when the headset battery is well charged.
Red and blue	<ul style="list-style-type: none">• Alternate slowly when the headset is not registered.• Alternate quickly when the headset is trying to register to a headset base.
Off	<ul style="list-style-type: none">• The battery is depleted.• No battery is installed.• The headset is powered off.

Getting started

Headset overview

VOL+/VOL-

Slide the volume switch to the right or left to adjust the headset ringer volume while in idle mode (page 19), or the listening volume while on a call (page 20).

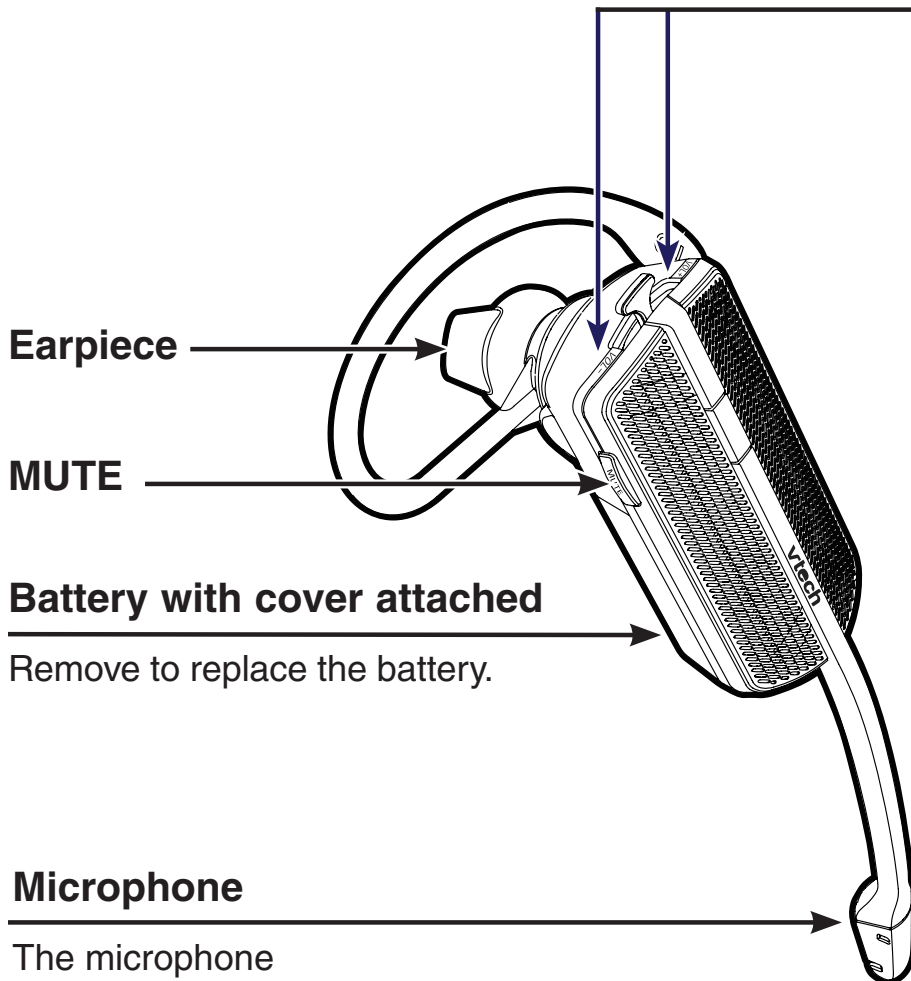

Earpiece

MUTE

Battery with cover attached

Remove to replace the battery.

Microphone

The microphone incorporates noise canceling technology for clearer calls.

Getting started

Headset overview

Headset alert tones

One short beep every 30 seconds	<ul style="list-style-type: none">• The microphone is muted.
Two beeps	<ul style="list-style-type: none">• Error alert tone.• The speaking volume has reached its highest or lowest setting.• Any key is pressed while the headset is out of range.
Two low beeps	<ul style="list-style-type: none">• Call waiting alert tone.
Two rapid beeps every 20 seconds	<ul style="list-style-type: none">• Low battery warning.
Three rising beeps	<ul style="list-style-type: none">• A conference call has started.
Three rapid beeps every 20 seconds	<ul style="list-style-type: none">• The headset is out of range.• The headset is not yet registered.
Three rapid beeps	<ul style="list-style-type: none">• The headset is powering on or off.

Getting started

Headset charger overview

Magnetic charging mount

Place the headset here
for charging.

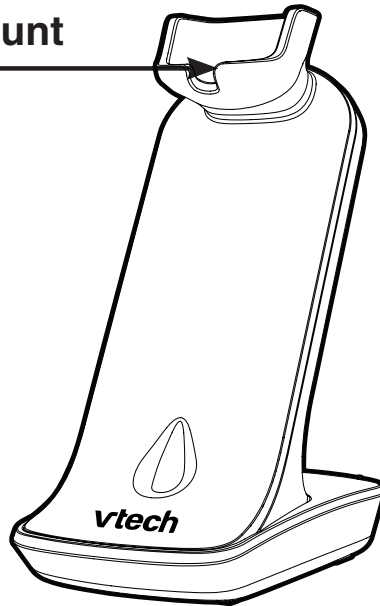

Getting started

Dongle overview

Pair button

Press and hold for about 4 seconds to enter the registration mode.

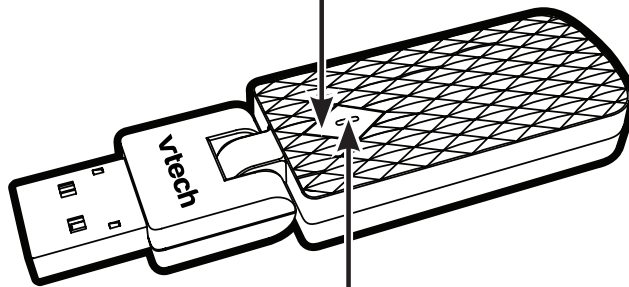

Dongle LED light

Flashes slow while in the registration mode.

Dongle lights

LED light status	
Blue	<ul style="list-style-type: none">• Steady blue when the Dongle is plugged into your PC.• Flashes very quickly every four seconds when there is an incoming call from the VTech Softphone Call Manager.• Flashes quickly every three seconds when the headset is in use.• Flashes moderately when the Dongle is under deregistration.• Flashes slowly when when the Dongle is registering to the headset

Getting started

Battery installation

The battery is permanently attached to the battery compartment cover. Do not try to separate them from each other. After installing the battery pack, charge it for at least 15 minutes. You may be able to make and receive short calls. For optimal performance, charge the headset battery for at least three hours before use. When fully charged, the headset battery provides approximately 12 hours of talk time or 5 days of standby time. When the headset is not in use, recharge by returning it to the headset charger.

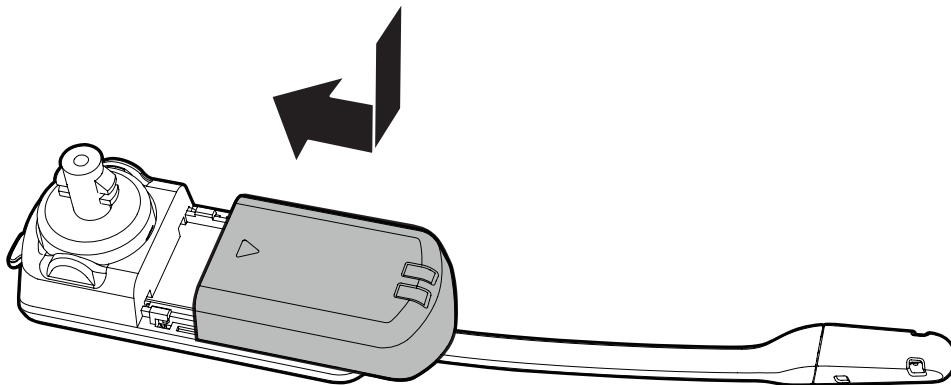

1. Insert the battery pack into the battery compartment.
2. Press down on the battery pack until it clicks into place.



NOTES:

- Remove any headset attachment (earbud excluded) before battery replacement.
- To order a replacement battery pack (model BT191665), visit our website at businessphones.vtech.com or call 1 (800) 595-9511. In Canada, dial 1 (866) 267-7377.

Getting started

Headset charger installation and battery charging

After installing the battery, charge the headset by placing it in the magnetic charging mount, as shown below. The  LED light turns on when the headset is charging.

1. Plug the small end of the headset charger power adapter at the back of the headset charger.

Plug the large end into an electrical outlet not controlled by a wall switch.

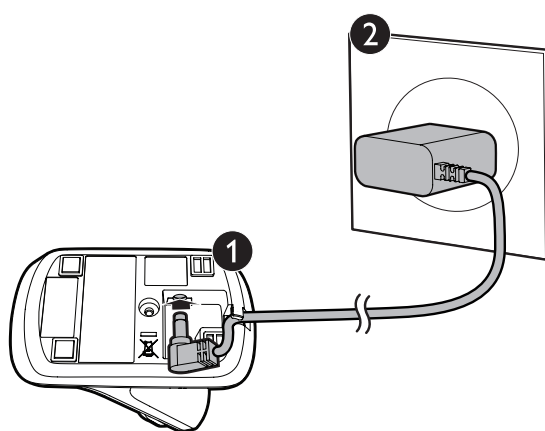

2. Insert the headset into the magnetic charging mount.

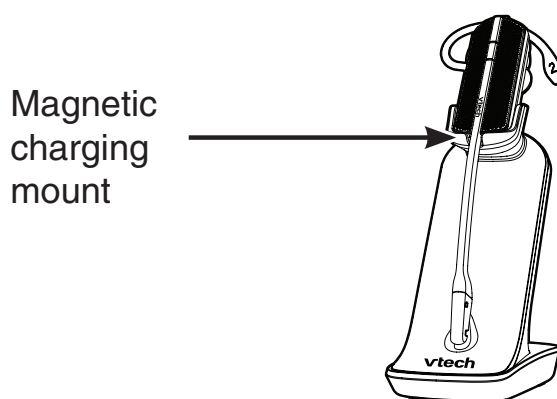

3. The magnet holds the top of the headset in place. The  light turns on.

Getting started

Connect the Dongle to a computer

Connect the Dongle of your headset to a computer

After connecting the Dongle of your headset to a computer, you can then use the headset for VoIP (Voice over IP) calls through your computer.



NOTE: You can use the voice command feature to make or answer calls. Make sure you install the **VTech Softphone Call Manager** on your computer. Visit www.vtechphones.com/downloads to download and install the software. For installation and operation instructions of the software, refer to the **Installation and Operation Guide**.

1. Plug the Dongle to the USB port on your computer. Wait for your computer to indicate that it has recognized the Dongle.
2. Install the **VTech Softphone Call Manager**. You can visit www.vtechphones.com/downloads to download and install the software. For installation and operation instructions of the software, refer to the **Installation and Operation Guide**.

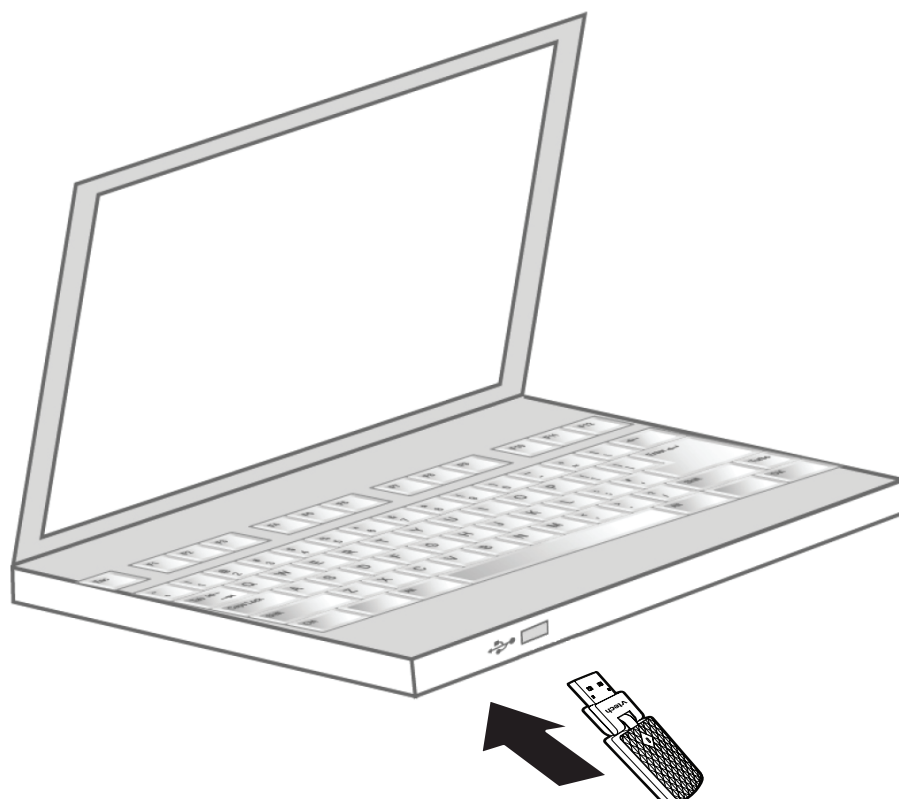

Getting started

Connect the Dongle to a computer

3. After you have installed the **VTech Softphone Call Manager**, check to make sure the audio setting is properly configured in your Windows system. If you have installed Skype and/or Skype for Business and want to use them with your headset, make sure the audio settings are configured correctly in the programs as well.

a) Audio settings in Microsoft® Windows® system:

For Windows XP® users:

- i. Click **Start** menu and choose **Control Panel**.
- ii. Click **Sounds, Speech, and Audio Devices** and then click **Sounds and Audio Devices**.
- iii. Click the **Audio** tab.
- iv. Make sure **VTech DECT Headset** is selected under the **Sound playback** and **Sound recording** settings.

For Windows 7 users:

- i. Click **Start** menu and choose **Control Panel**.
- ii. Click **Hardware and Sound** and then click **Manage audio devices** under the **Sound** menu.
- iii. Click the **Playback** tab and make sure **VTech DECT Headset** is set as the default speaker.
- iv. Click the **Recording** tab and make sure **VTech DECT Headset** is set as the default microphone.

Getting started

Connect the Dongle to a computer

b) Audio settings in Skype:

- i. Launch the Skype program.
- ii. Click on **Tools**, then **Options**.
- iii. Click on **Audio settings**.
- iv. Make sure **VTech DECT Headset** is selected under the speakers and microphone settings.

c) Audio settings in Skype for Business:

- i. Launch the Microsoft Lync program.
- ii. Click on **Options**, then **Audio Device**.
- iii. Make sure **VTech DECT Headset** is selected under the Audio device setting.

IMPORTANT INFORMATION

Periodically check for software updates. Go to the **ABOUT** tab under the **Settings** panel in the **VTech Softphone Call Manager**, then click **Check Update**. For more details, refer to the **Software updates** section in the **Installation and Operation Guide**.

Getting started

Position the headset

Over-the-ear hook

There are four earbuds and four earhooks provided. One earbud and one earhook have been attached to the headset.

You can choose a suitable size of earbud, earhook and an appropriate way to position your headset.

Replace the pre-installed earbud and earhook:

1. Hold both sides of the earbud. Twist and pull the earbud until it separates from the earpiece.

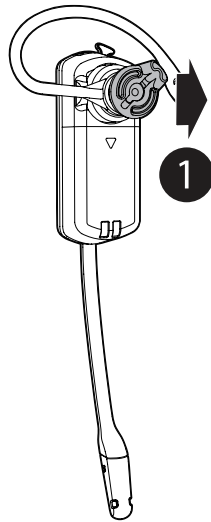

2. Rotate the earhook to vertical direction and then pull the earhook until it separates from the headset.

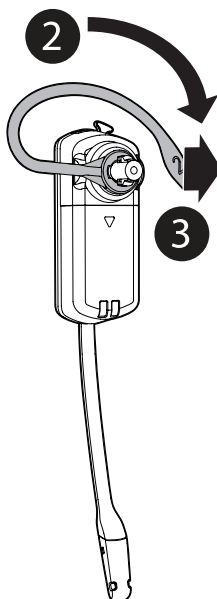

Getting started

Position the headset

3. Attach an earhook, and then a suitable earbud to the headset until they fit into place.

To wear on the right ear:

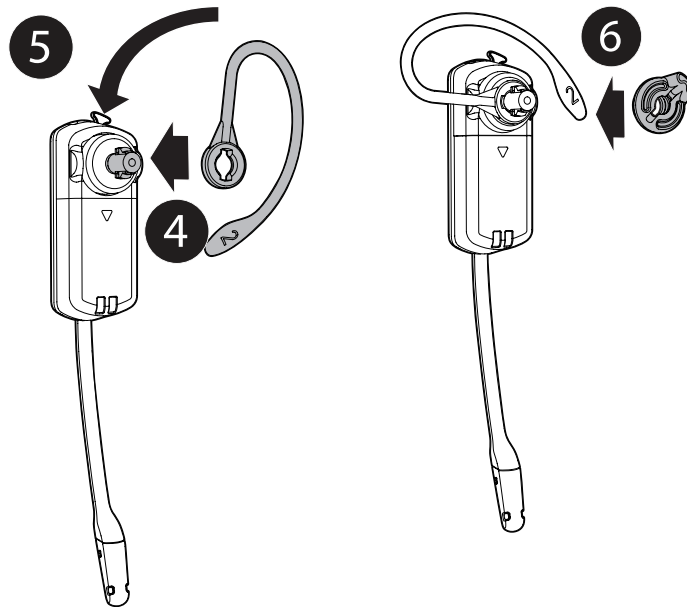

To wear on the left ear:

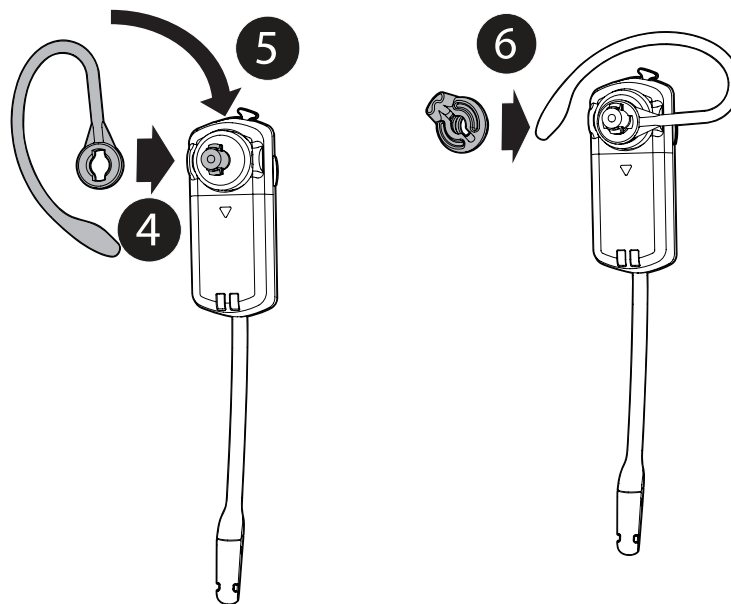

Getting started

Position the headset

Replace the pre-installed earbud and earhook:

- Hook the headset on your ear. Adjust the angle of the headset until the microphone is pointing towards your mouth. Firmly grip the headset with one hand whenever adjusting the headset microphone up or down.

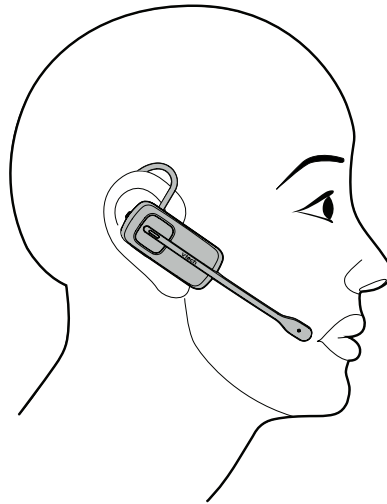

Getting started

Position the headset

Over the head band

To attach the head band to the headset:

1. Refer to Steps 1 and 2 in **Replace the pre-installed earbud and earhook section** to remove the earbud and earhook.
2. Attach the headset to the headband. With the headset at a vertical angle (microphone pointing down), insert the earpiece into the headband.
3. Rotate the headset in a horizontal direction until it clicks into place.

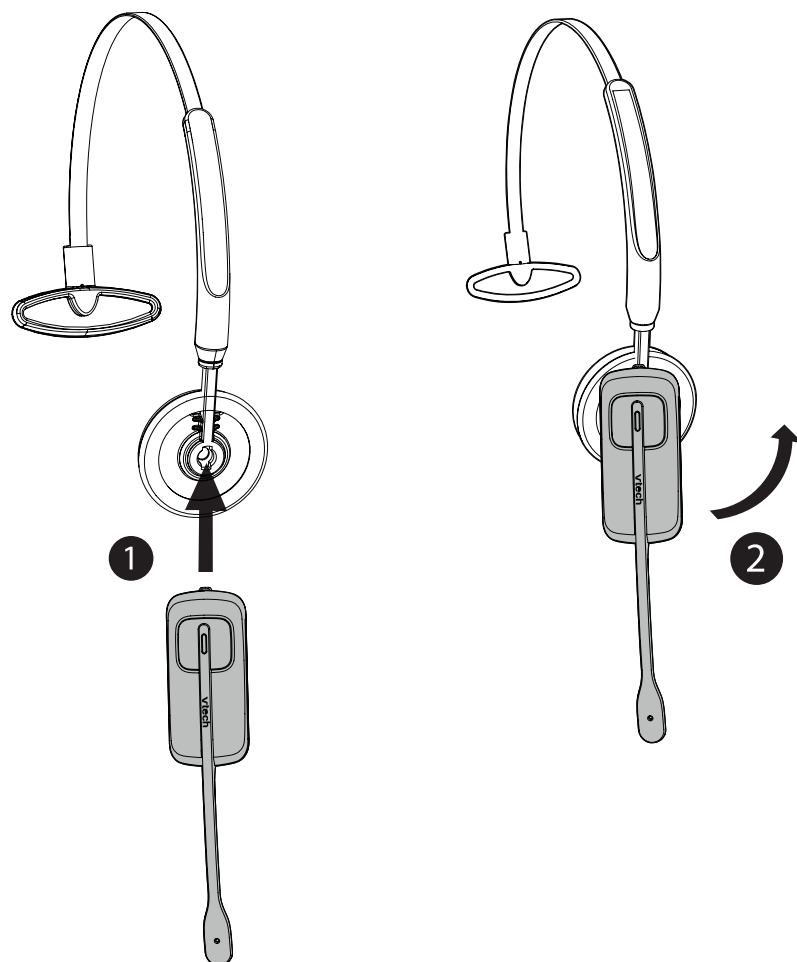

4. Adjust the head band to fit your head. Adjust and rotate the angle of the headset until the microphone is pointing towards your mouth.

Getting started

Position the headset

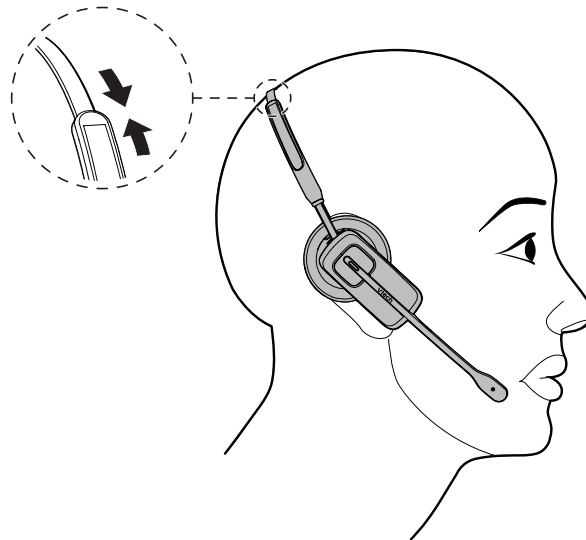

To remove the head band from the headset:

1. Hold the headset with one hand and the headband with your other hand.
2. Rotate the headset downwards to a vertical position and then pull out the headset until it separates from the head band.

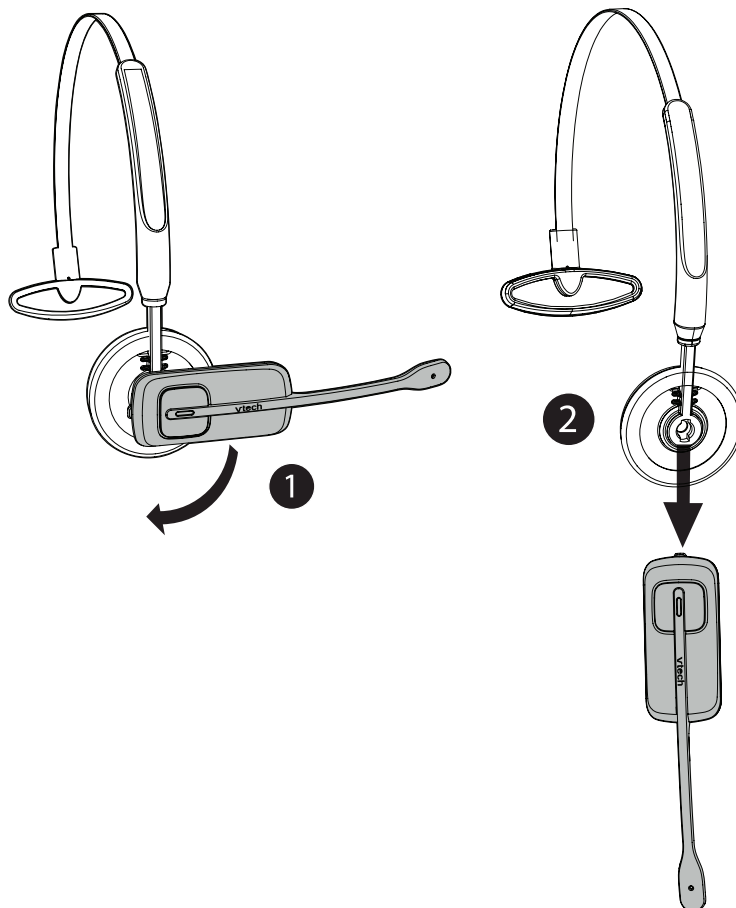

Getting started

Position the headset

Behind-the-neck band

By default, the ear pad on the neck band is positioned to be worn on the right ear.

To attach the headset to the neck band:

1. Refer to Steps 1 and 2 in **Replace the pre-installed earbud and earhook section** to remove the earbud and earhook.
2. Attach the headset to the headband. With the headset at a vertical angle (microphone pointing down), insert the earpiece into the neckband.
3. Rotate the headset in a horizontal direction until it clicks into place.

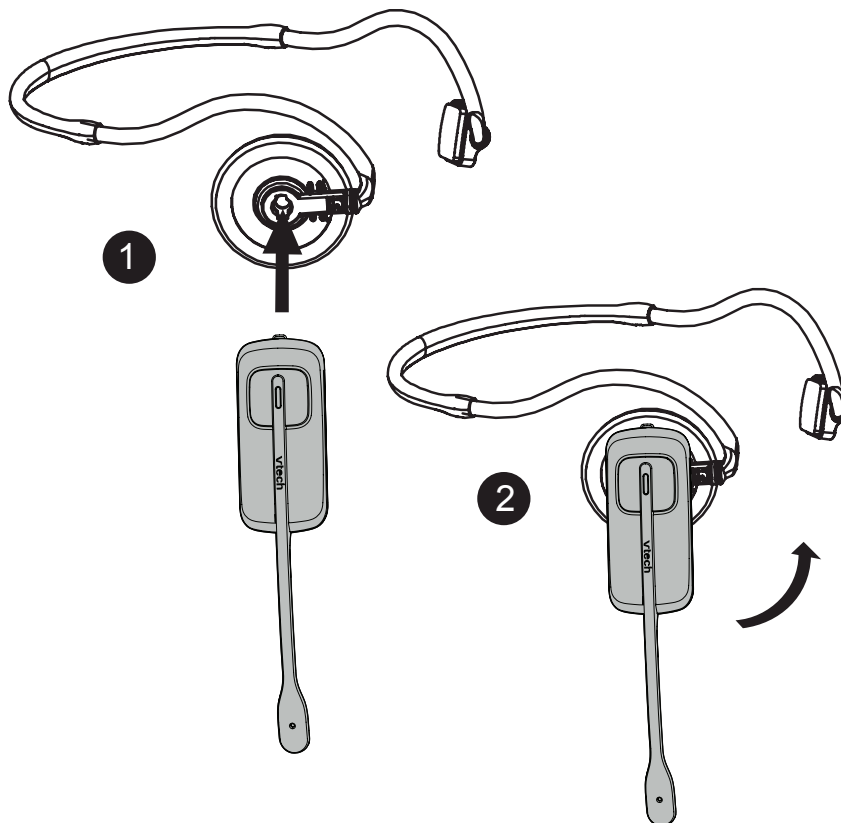

Getting started

Position the headset

4. Place the neck band around your neck and over your ears.
5. Adjust and rotate the angle of the headset until the microphone is pointing towards your mouth.

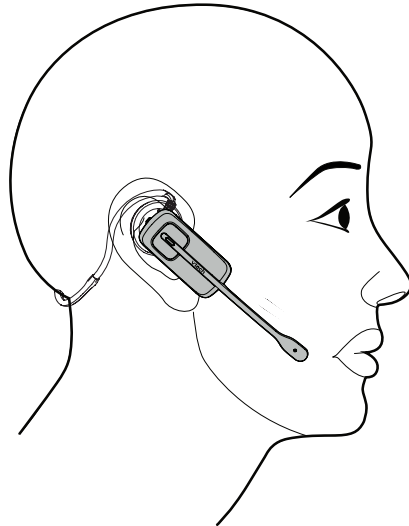

Operation

Headset operation

Before use

Make sure to have connected your registered Dongle of your headset to your computer, and have already installed the **VTech VTech Softphone Call Manager** on your computer before you can use your headset. Visit www.vtechphones.com/downloads to download and install the software.

Power on/off the headset

Power on the headset before use.

To power on the headset:

- Place the headset in the charger cradle.

-OR-

- Press and hold  **ON/OFF** button for two seconds.

The  LED light flashes blue three times and you hear three beeps when it is being powered on.

Power off the headset if it will not be used for a long time.

To power off the headset:

- Press and hold  **ON/OFF** button for four seconds.

The  LED light flashes red three times and you hear three beeps when it is being powered off.



Prolonged exposure to high volume levels using the headset may damage your hearing.

Answer a call

- Press the  **ON/OFF** button on the headset

End a call

- Press the  **ON/OFF** button on the headset

Operation

PHONE mode

Voice command

The voice command feature enables you to make or answer calls using certain voice commands via **VTech Softphone Call Manager** on your computer.

For detailed instructions of the voice command feature, refer to the **Installation and Operation Guide**.

Headset ringer

The headset does not have external ringers. When you receive calls, the headset earpiece rings.

To change the volume of the earpiece ringer:

- Slide the volume switch at the top of the headset towards **VOL+** or **VOL-** when the headset is not in use.

To turn off the earpiece ringer:

- Slide the volume switch at the top of the headset towards **VOL-** until you hear two beeps when the headset is not in use.

Caller ID announce

The Caller ID Announce feature with your **VTech Softphone Call Manager** lets you know who is calling without having to look at the display.

For detailed instructions of the caller ID announce feature, refer to the **Installation and Operation Guide**.

Temporary ringer silencing

Press **MUTE** to temporarily silence the ringer in the headset earpiece. This silences the ringer without disconnecting the call. The next incoming call rings normally at the preset volume.

Operation

Options while on calls

Volume control

To adjust the listening volume:

- While on a call, slide the volume switch at the top of the headset towards **VOL+** or **VOL-** to adjust the listening volume.



NOTE:

- When the listening volume reaches the minimum or maximum setting, you hear two beeps.

Mute

The mute function turns off the headset microphone. You can hear the caller, but the caller cannot hear you.

To mute a call:

- Press **MUTE** on the headset to turn off the headset microphone. The voice prompt "*Mute on*" plays.

To take a call off mute:

- Press **MUTE** on the headset to resume the two-way conversation. You hear the voice prompt "*Mute off*".

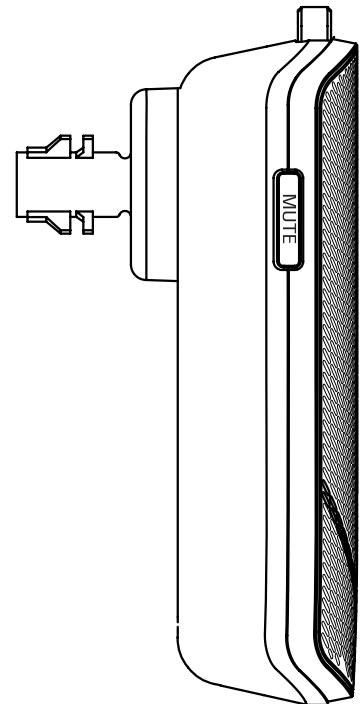



Appendix

Registering Headset to Dongle



Register your Headset to the Dongle

The VH6212 headset comes pre-registered to the Dongle. If, for some reason, the headset is not registered to the Dongle, follow the instructions below to register your headset to the Dongle.

1. Make sure the battery is properly installed in the headset (see page 6). The  LED light flashes slowly in red and blue to indicate the headset is not registered.
2. Place the headset in the charger cradle and allow it to charge for at least one hour before beginning registration.
3. Remove the headset from the charger cradle.
4. Press and hold the pair button on the Dongle for about four seconds until the Dongle LED light on flashes blue slowly, and then release the button.
5. Return the headset to the charger cradle for registration. The  LED light alternates quickly in red and blue.

It takes about 60 seconds to complete the registration process.

Once the headset is registered, The  LED light turns red when the battery is low and being charged, or turns purple when the battery is well charged, or turns blue when the battery is fully charged.

If the registration fails, you hear the voice prompt "*Not registered*" when you press the  **ON/OFF** button on the headset, and the  **ON/OFF** button light on the headset alternates slowly in red and blue.

To reset the headset, remove it from the charger cradle and try the registration process again.



NOTE: You cannot register a headset if another system headset is in use.

Appendix

Deregistering headset

You may need to deregister your headset from the Dongle if:

You wish to register your headset to a VTech DECT 6.0 cordless telephone or a headset base.

Please read carefully through all the instructions on this page before beginning the deregistration process.

Deregister all headsets from your Dongle

1. Press and hold the pair button on the Dongle for about four seconds until the Dongle LED light flashes blue slowly, and then release the button.
2. Immediately press the pair button again. The Dongle LED light will flash blue moderately.
3. Immediately press the pair button once again.

It takes about 10 seconds to complete the deregistration process. The  light alternates slowly in red and blue when the deregistration process is successful.



NOTES:

- You cannot deregister the headset(s) if any system headset is in use.
- To deregister all headsets from a VTech DECT cordless telephone base, see the user's manual of your cordless telephone system.

Appendix

Troubleshooting

If you have difficulty with your product, please try the following suggestions. For customer service, visit our website at **businessphones.vtech.com** or call **1 (800) 222-3111**. In Canada, dial **1 (866) 267-7377**.

My headset doesn't work at all. There is no dial tone. I cannot dial out.

- Make sure the power cord is securely plugged in.
- Make sure that the battery is securely installed in the headset.
- Make sure the registered Dongle of your headset is plugged into your computer and the **VTech Softphone Call Manager** is properly installed. Visit **www.vtechphones.com/downloads** to download **VTech Softphone Call Manager** if necessary.
- Make sure you have pressed  on your headset to receive the audio from your computer.
- Make sure you are using a software program that supports VoIP calling (such as Skype or Skype for Business).
- Make sure the headset listening volume is turned on and set to an audible level in your computer audio settings and your VoIP calling software.
- Make sure the audio settings in your VoIP calling software are set to use your "VTech DECT Headset".
- Charge the battery in the cordless headset for at least three hours. For optimum daily performance, return the cordless headset to its base when not in use.
- Reset the headset. Power off the headset and then power it on (page 18). Allow up to one minute for the cordless headset and headset charger to reset.
- Reset the headset charger. Unplug the unit's electrical power. Wait for approximately 15 seconds, then plug it back in. Allow up to one minute for the cordless headset and headset charger to reset.

Appendix



Troubleshooting

- Other electronic products such as HAM radios and other DECT phones, can cause interference with your cordless headset. Try installing your headset charger as far away as possible from these types of electronic devices.
- You may need to purchase a new battery. Refer to the **Battery installation** section on page 6 of this user's manual.

The other party cannot hear my voice during a call.

- Adjust the speaking volume during a call (page 20).

The battery does not charge.

- Make sure that the battery is securely installed in the cordless headset.
- If the cordless headset is in its headset charger but the  light on the headset does not turn on, refer to **The  light on the headset is off while charging** in this **Troubleshooting** guide.
- Charge the battery in the cordless headset for at least three hours. For optimum daily performance, return the cordless headset to the headset charger when not in use.
- You may need a new battery. Refer to the **Battery installation** section on page 6.
- Your headset might be defective. Refer to the **Limited warranty** section on pages 40-42 for further instructions.

My cordless headset isn't performing normally.

- Make sure the power cord is securely plugged into the headset charger. Plug the unit into a different, working electrical outlet not controlled by a wall switch.
- Reset the headset. Power off the headset and then power it on (page 18). Allow up to one minute for the cordless headset and headset charger to reset.

Appendix

Troubleshooting

- Reset the headset charger. Unplug the unit's electrical power. Wait for 15 seconds, then plug it back in. Allow up to one minute for the cordless headset and headset charger to reset.
- Other electronic products such as HAM radios and other DECT phones, can cause interference with your cordless headset. Try installing your headset as far away as possible from these types of electronic devices.

I get noise, static, or a weak signal even when I'm near the headset charger.

- You may be able to improve the performance of your cordless headset by installing the headset charger at least one foot from any cordless telephone system. If separating them by one foot does not help, try moving the headset farther away.
- Other electronic products such as HAM radios and other DECT phones, can cause interference with your cordless headset. Try installing your headset as far away as possible from these types of electronic devices.
- Do not install this headset near a microwave oven or in the same electrical outlet. You may experience decreased performance while the microwave oven is operating.
- If your headset is located near a modem, move your headset and modem further apart from each other.
- Relocate your headset charger to a higher location. You may experience better reception by elevating the headset charger.
- If other phones in your home or office are having the same problem, the problem is in your wiring or local service. Contact your telephone service provider (charges may apply).

I cannot hear a ring tone from the headset when there is an incoming call.

- The headset does not have an external ringer. You can only hear the ring tone when you are wearing the earpiece.

Appendix

Troubleshooting

- If you have pressed **MUTE** on the headset when it is ringing, it mutes the ring tone of the headset. The ring tone resumes on the next call.
- Other electronic products such as HAM radios and other DECT phones, can cause interference with your cordless headset. Try installing your headset charger as far away as possible from these types of electronic devices.
- Install the battery again, and then place the cordless headset in the headset charger. Wait for the cordless headset to reestablish its connection with the headset charger. Allow up to one minute for this to take place.
- Your telephone line cord may be defective. Install a new telephone line cord.
- If other phones in your home or office are having the same problem, the problem is in your wiring or local service. Contact your telephone service provider (charges may apply).
- Test a working phone at the phone jack. If another phone has the same problem, there may be a problem with the phone jack, wiring or service. Contact your telephone service provider (charges may apply).

I want to use my headset with a headset base.

- You need to deregister the headset from the current Dongle base (page 22), and then register it to the new headset base.

My calls cut in and out while I'm using my cordless headset.

- Other electronic products such as HAM radios and other DECT phones, can cause interference with your cordless headset. Try installing your headset charger as far away as possible from these types of electronic devices.

Appendix

Troubleshooting

- Do not install the headset near a microwave oven or on the same electrical outlet. You may experience decreased performance while the microwave oven is operating.
- If your headset is located near a modem, move your headset and modem further apart from each other.
- If other phones in your home or office are having the same problem, the problem is in your wiring or local service. Contact your telephone service provider (charges may apply).

The light on the headset is off while charging.

- Make sure the power and line cords are plugged in correctly and securely.
- Make sure that the battery is securely installed in the cordless headset.
- Make sure the headset is sitting properly on the base to charge.
- Unplug the unit's electrical power. Wait for 15 seconds, then plug it back in. Allow up to one minute for the cordless headset and headset charger to reset.
- Clean the cordless headset and charging contacts each month using a pencil eraser or dry cloth.
- Your headset or headset charger might be defective, you might need to purchase a new set for replacement.

The other party cannot hear my voice during a call.

- Make sure your headset microphone is not muted.

Appendix

Troubleshooting

Common cure for electronic equipment.

If the unit does not seem to be responding normally, try putting the cordless headset in its base. If it does not respond, do the following (in the order listed):

- Disconnect the power to the headset charger.
- Remove the cordless headset battery.
- Wait a few minutes.
- Connect the power to the headset charger.
- Install the battery again, and then place the cordless headset into the headset charger.
- Wait for the cordless headset to reestablish its connection with the headset charger. Allow up to one minute for this to take place.

Appendix

Maintenance

Taking care of your headset

- Your cordless headset contains sophisticated electronic parts, so it must be treated with care.
- Avoid rough treatment.
- Place the headset down gently. Save the original packing materials to protect your headset if you ever need to ship it.

Avoid water

- Your headset can be damaged if it gets wet. Do not use the headset outdoors in the rain, or handle it with wet hands. Do not install the headset charger near a sink, bathtub or shower.

Electrical storms

- Electrical storms can sometimes cause power surges harmful to electronic equipment. For your own safety, take caution when using electrical appliances during storms.

Cleaning your headset

- Your headset has a durable plastic casing that should retain its luster for many years. Clean it only with a soft cloth slightly dampened with water or a mild soap.
- Do not use excess water or cleaning solvents of any kind.

Remember that electrical appliances can cause serious injury if used when you are wet or standing in water. If the headset charger should fall into water, DO NOT RETRIEVE IT UNTIL YOU UNPLUG THE POWER CORD AND TELEPHONE LINE CORD FROM THE WALL, then pull the unit out by the unplugged cords.

Appendix

Important safety information

When using your equipment, basic safety precautions should always be followed to reduce the risk of fire, electric shock and injury, including the following:

Safety information

- **Read and understand all instructions in the user's manual. Observe all markings on the product.**
- **Avoid using a headset during a thunderstorm.** There may be a slight chance of electric shock from lightning.
- **Do not use the headset to report a gas leak in the vicinity of the leak.** Under certain circumstances, a spark may be created when the adapter is plugged into the power outlet, or when the headset is replaced in its cradle. This is a common event associated with the closing of any electrical circuit. The user should not plug the headset charger into a power outlet, and should not put a charged headset into the cradle, if the headset charger is located in an environment containing concentrations of flammable or flame-supporting gases, unless there is adequate ventilation. A spark in such an environment could create a fire or explosion. Such environments might include: medical use of oxygen without adequate ventilation; industrial gases (cleaning solvents; gasoline vapors; etc.); a leak of natural gas; etc.
- **Do not use this product near water, or when you are wet.** For example, do not use it in a wet basement or shower, or next to a swimming pool, bathtub, kitchen sink, or laundry tub. Do not use liquids or aerosol sprays for cleaning. If the product comes in contact with any liquids, unplug any line or power cord immediately. Do not plug the product back in until it has dried thoroughly.
- **Install this product in a protected location** where no one can trip over any line or power cords. Protect cords from damage or abrasion.
- **If this product does not operate normally, see the Troubleshooting section of this user's manual.** If you cannot solve the problem, or if the product is damaged, refer to the **Limited warranty** section on pages 40-42. Do not open this product except as may be directed in your user's manual. Opening the product or reassembling it incorrectly may expose you to hazardous voltage or other risks.
- **Replace batteries only as described in your user's manual (page 6).** Do not burn or puncture batteries — they contain caustic chemicals.
- **This power adapter is intended to be correctly oriented in a vertical or floor mount position.** The prongs are not designed to hold the plug in place if it is plugged into a ceiling, an under-the-table or a cabinet outlet.

Appendix

Important safety information



CAUTIONS

- Use only the power adapter provided with this product. To obtain a replacement, visit our website at **businessphones.vtech.com** or call **1 (800) 595-9511**. In Canada, dial **1 (866) 267-7377**.
- Use only the supplied rechargeable battery or replacement battery (model BT191665). To order, visit our website at **businessphones.vtech.com** or call **1 (800) 595-9511**. In Canada, dial **1 (866) 267-7377**.
- To prevent risk of fire or battery explosion, replace with the correct battery type. Dispose of used batteries according to the instructions.

Especially about cordless headsets

- **Privacy:** The same features that make a cordless headset convenient create some limitations. Telephone calls are transmitted between the headset charger and the headset by radio waves, so there is a possibility that your cordless headset conversations could be intercepted by radio receiving equipment within range of the cordless headset. **For this reason, you should not think of cordless headset conversations as being as private as those on corded telephones.**
- **Electrical power:** The headset charger of this cordless headset must be connected to a working electrical outlet which is not controlled by a wall switch. **Calls cannot be made from the headset if the headset charger is unplugged or switched off, or if the electrical power is interrupted.**
- **Potential TV interference:** Some cordless headsets operate at frequencies that may cause interference to TVs and VCRs. To minimize or prevent such interference, do not place the headset charger of the cordless headset near or on top of a TV or VCR. If interference is experienced, moving the cordless headset farther away from the TV or VCR will often reduce or eliminate the interference.
- **Rechargeable batteries:** This product contains lithium-ion rechargeable batteries. Exercise care in handling batteries in order not to create a short circuit with conductive material such as rings, bracelets and keys. The battery or conductor may overheat and cause harm. Observe proper polarity between the battery and the battery charger.
- **Lithium-ion rechargeable batteries:** Dispose of these batteries in a safe manner. Do not burn or puncture. Like other batteries of this type, if burned or punctured, they could release caustic material which could cause injury.

Appendix

Important safety information



The RBRC® Seal means that the manufacturer is voluntarily participating in an industry program to collect and recycle lithium-ion rechargeable batteries when taken out of service within the United States. These batteries may be taken to a participating local retailer of replacement batteries or recycling center. You may call 1-800-8-BATTERY® for locations accepting spent Li-ion batteries.

RBRC® and 1-800-8-BATTERY® are registered trademarks of the Rechargeable Battery Recycling Corporation.

CAUTIONS

- There may be a risk of explosion if you use a wrong type of battery. Use only the supplied rechargeable battery or replacement battery (model BT191665).
- Change this product's batteries only in accordance with the instructions and limitations specified in this manual.
- As with any batteries, do not allow conductive materials such as rings, bracelets or keys to come in contact with the metallic parts of the battery. The battery or conductor may overheat and cause harm.
- Do not open or damage the batteries. Released electrolyte is corrosive and may cause injury to the eyes or skin. The electrolyte may be toxic if swallowed.
- Do not dispose of the batteries in a fire. Check with local waste management codes for special disposal instructions. To prevent fire or shock hazard, do not expose this product to water or any type of moisture.
- Observe proper polarity orientation between the battery and metallic contacts.
- Do not disassemble your headset. There are no user-serviceable parts inside. Refer to qualified service personnel for servicing.
- For pluggable equipment, the socket-outlet shall be installed near the equipment and shall be easily accessible.

Precautions for users of implanted cardiac pacemakers

Cardiac pacemakers (applies only to digital cordless devices):

Wireless Technology Research, LLC (WTR), an independent research entity, led a multidisciplinary evaluation of the interference between portable digital cordless devices and implanted cardiac pacemakers. Supported by the U.S. Food and Drug Administration, WTR recommends to physicians that:

Pacemaker patients

- Should keep digital cordless devices at least six inches from the pacemaker.
- Should NOT place digital cordless devices directly over the pacemaker, such as in a breast pocket, when it is turned ON.
- Should use the digital cordless device at the ear opposite the pacemaker.

WTR's evaluation did not identify any risk to bystanders with pacemakers from other persons using digital cordless devices.

SAVE THESE INSTRUCTIONS

Appendix

For C-UL compliance

In compliance with the bilingual requirements for safety, caution, and warning markings of Canadian Federal and Provincial/Territorial statutes and regulations, the French version of Important safety information is included.

Mesures de sécurité importantes

Lorsque vous utilisez votre appareil, vous devriez toujours suivre certaines mesures de précaution de base afin de réduire les risques d'incendie, d'électrocution et de blessures corporelles, dont ceux qui suivent :

Information relative à la sécurité

- **Veillez lire et comprendre toutes les instructions de ce guide d'utilisation. Relectez toutes les inscriptions apparaissant sur le produit.**
- **Évitez d'utiliser le casque d'écoute pendant un orage.** Il pourrait y avoir un faible risque d'électrocution.
- **N'utilisez pas un casque d'écoute près d'une fuite de gaz.** Dans certaines circonstances, une flammèche pourrait se produire lorsque l'adaptateur est branché à une prise de courant, ou lorsque le casque d'écoute est déposé sur son chargeur. Ceci est un événement fréquent associé avec la fermeture d'un circuit électrique. L'utilisateur ne devrait pas brancher un téléphone dans une prise de courant, et ne devrait pas déposer un casque d'écoute chargé dans son chargeur, si le chargeur du casque d'écoute se trouve dans un environnement comportant une concentration de gaz inflammables ou ignifuges, à moins de se trouver dans un endroit où la ventilation est adéquate.
- **N'utilisez pas ce produit près de l'eau ou lorsque vous êtes mouillés.** Par exemple, ne l'utilisez pas dans des sous-sols humides ou sous la douche, ou près d'une piscine, d'un bain, d'un évier de cuisine, ou d'une cuve de lavage. N'utilisez pas de liquides, ou de vaporisateurs aérosol de nettoyage. Si le produit entre en contact avec du liquide, débranchez immédiatement le fil téléphonique ou le cordon d'alimentation. Ne rebranchez pas le produit avant qu'il soit complètement sec.
- **Installez cet appareil dans un endroit protégé** où personne ne peut trébucher sur les cordons d'alimentation ou la ligne téléphonique. Protégez les câbles contre les dommages ou l'abrasion.
- **Si le produit ne fonctionne pas correctement, consultez la section Dépannage (Troubleshooting) de ce guide d'utilisation.** Si vous ne pouvez pas régler le problème, ou si le produit est endommagé, consultez la section **Garantie limitée (Limited warranty)** des pages 40-42. N'ouvrez pas ce produit, sauf tel qu'indiqué dans le guide d'utilisation. L'ouverture du produit ou le remontage inadéquat pourrait vous exposer à des tensions dangereuses ou autres dangers.

Appendix

For C-UL compliance

- **Remplacez les piles uniquement tel que décrit dans votre guide d'utilisation (page 6).** N'incinérez pas et ne percez pas les piles — elles contiennent des produits chimiques caustiques.
- **L'adaptateur de courant est conçu pour être orienté verticalement ou installé sur le plancher.** Les broches ne sont pas conçues pour se maintenir en place si la fiche est branchée dans une prise de courant au plafond, sous la table ou sous une armoire.



MISES EN GARDE

- N'utilisez seulement l'adaptateur inclus avec ce produit. Pour obtenir une pièce de rechange, visitez notre site Web au **businessphones.vtech.com** ou composez le **1 (800) 595-9511**. Au Canada, composez le **1 (866) 267-7377**.
- N'utilisez que la pile de rechargeable incluse ou une pile de rechange (modèle BT191665). Pour commander, visitez notre site Web **businessphones.vtech.com** ou composez le **1 (800) 595-9511**. Au Canada, composez le **1 (866) 267-7377**.
- Afin de prévenir les risques d'incendie ou d'explosion de la pile, remplacez la pile avec une pile du même type. Jetez les piles épuisées en respectant les instructions.

Spécifiquement en rapport avec casque d'écoute sans fil

- **Confidentialité :** Les mêmes caractéristiques qui rendent le casque d'écoute sans fil si pratique créent également des restrictions. Les appels téléphoniques sont transmis entre le socle du casque d'écoute et le casque d'écoute par le biais d'ondes radio, et il se peut que vos conversations téléphoniques sur le casque d'écoute sans fil soient interceptées par d'autres équipements de réception d'ondes radio au sein de la portée du casque d'écoute sans fil. **Pour cette raison, vous ne devez pas considérer les conversations sur un téléphone sans fil comme étant aussi confidentielles que celles d'un téléphone à cordon.**
- **Alimentation électrique :** La base de ce téléphone sans fil (de ce casque d'écoute sans fil) doit être branchée à une prise de courant électrique fonctionnelle. La prise électrique ne doit pas être contrôlée par un interrupteur mural. **Les appels ne peuvent pas être effectués à partir du socle du casque d'écoute n'est pas branchée, si elle est hors fonction ou si le courant électrique est coupé.**

Appendix

For C-UL compliance

- **Interférences potentielles aux téléviseurs:** Certains casques d'écoute sans fil fonctionnent sur des fréquences pouvant causer des interférences aux téléviseurs et magnétoscopes. Pour réduire ou prévenir de tels parasites, ne pas déposer le socle du casque d'écoute à proximité d'un téléviseur ou magnétoscope, ni directement sur celui-ci. Si votre téléviseur affiche des interférences, éloignez le casque d'écoute sans fil de celui-ci afin de réduire les parasites.
- **Piles rechargeables:** Ce produit comporte des piles rechargeables au lithium-ion. Utilisez de prudence lorsque vous manipulez de telles piles et veillez à ne pas les court-circuiter avec des matériaux conducteurs, tels que des bagues, bracelets et clés. La pile ou le conducteur peut surchauffer et vous brûler. Respectez la polarité adéquate entre les piles et le chargeur de piles.
- **Piles rechargeables au lithium-ion:** Jetez ces piles de manière sécuritaire. N'incinerez pas et ne percez pas les piles. Comme pour les autres piles du même type, si elles sont brûlées ou percées, des matières corrosives peuvent s'en échapper, ce qui risque de causer des brûlures ou autres blessures corporelles.



Le sceau de l'organisme de recyclage RBRC^{MD} sur les piles au lithium-ion signifie que le fabricant de cet appareil participe volontairement au programme industriel visant à reprendre et recycler ce type de piles lorsqu'elles ne servent plus, au sein du territoire des États-Unis et du Canada. Vous devez apporter ces piles chez un détaillant participant ou le centre de recyclage le plus près de chez vous. Ou vous pouvez composer le 1-800-8-BATTERY^{MD} afin de connaître les endroits qui acceptent les piles au lithium-ion mortes.

RBRC^{MD} et 1-800-8-BATTERY^{MD} sont des marques déposées de Rechargeable Battery Recycling Corporation.



MISES EN GARDE

- Il y a un faible risque d'explosion si vous utilisez le mauvais type de pile. N'utilisez que la pile rechargeable incluse ou conçue pour fonctionner avec votre appareil (modèle BT191665).
- Remplacez cette pile en respectant les instructions et les limitations spécifiées dans ce guide d'utilisation.
- Comme avec tout matériau conducteur, veillez à ne pas court-circuiter les bornes de la pile avec des matériaux conducteurs, tels que des bagues, bracelets et clés. La pile ou le conducteur peut surchauffer et vous brûler. La pile ou les conducteurs peuvent surchauffer et causer des blessures.

Appendix

For C-UL compliance

- N'ouvrez pas et n'endommagez les piles. L'électrolyte qui s'en dégagerait est corrosif et peut causer des blessures aux yeux ou à la peau. L'électrolyte est toxique si avalé.
- N'incinerez pas les piles. Vérifiez auprès des autorités locales pour les instructions de mise aux rebus locales. Afin de prévenir les risques d'incendies, n'exposez pas ce produit à l'eau ou à l'humidité.
- Veuillez respecter la polarité des piles et des bornes métalliques.
- Ne démontez pas votre casque d'écoute. Aucune pièce pouvant être réparée par l'utilisateur ne se trouve à l'intérieur de l'appareil. Confiez la réparation à un technicien qualifié.
- Pour les PRODUITS À BRANCHER À UNE PRISE DE COURANT, la prise de courant doit être installée près du produit, afin d'assurer une accessibilité sécuritaire à la prise de courant

Mesures préventives pour les utilisateurs de stimulateurs cardiaques implantés dans l'organisme

Stimulateurs cardiaques (ne s'applique qu'aux dispositifs numériques sans fil):

L'organisme 'Wireless Technology Research, LLC (WTR)', une firme de recherche indépendante, a mené une évaluation pluridisciplinaire des interférences entre les dispositifs numériques sans fil et les stimulateurs cardiaques implantés dans l'organisme. Appuyée par l'Administration des aliments et drogues (FDA) des États-unis, la firme WTR recommande aux médecins:

Avis aux détenteurs de stimulateurs cardiaques

- Ils doivent tenir les dispositifs numériques sans fil à une distance d'au moins six pouces du stimulateur cardiaque.
- Ils ne doivent PAS placer les dispositifs numériques sans fil directement sur le stimulateur cardiaque, tel que dans une poche de chemise, lorsque celui-ci est en fonction.
- Ils doivent utiliser les dispositifs numériques sans fil en les appuyant sur l'oreille qui se trouve dans la direction opposée au stimulateur cardiaque.

L'étude effectuée par l'organisme WRS n'a pas identifié de risque pour les détenteurs de simulateurs cardiaques causé par les gens qui utilisent des dispositifs numériques sans fil à proximité de ceux-ci.

CONSERVEZ CES INSTRUCTIONS

Appendix

FCC Part 15

This equipment has been tested and found to comply with the requirements for a Class B digital device under Part 15 of the Federal Communications Commission (FCC) rules.

These requirements are intended to provide reasonable protection against harmful interference in a residential installation. This equipment generates, uses and can radiate radio frequency energy and, if not installed and used in accordance with the instructions, may cause harmful interference to radio communications. However, there is no guarantee that interference will not occur in a particular installation.

If this equipment does cause harmful interference to radio or television reception, which can be determined by turning the equipment off and on, the user is encouraged to try to correct the interference by one or more of the following measures:

- Reorient or relocate the receiving antenna.
- Increase the separation between the equipment and receiver.
- Connect the equipment into an outlet on a circuit different from that to which the receiver is connected.
- Consult the dealer or an experienced radio/TV technician for help.

Changes or modifications to this equipment not expressly approved by the party responsible for compliance could void the user's authority to operate the equipment.

This device complies with Part 15 of the FCC Rules. Operation is subject to the following two conditions: (1) this device may not cause harmful interference, and (2) this device must accept any interference received, including interference that may cause undesired operation. Privacy of communications may not be ensured when using this device.

To ensure safety of users, the FCC has established criteria for the amount of radio frequency energy that can be safely absorbed by a user or bystander according to the intended usage of the product. This product has been tested and found to comply with the FCC criteria. Use of other accessories may not ensure compliance with FCC RF exposure guidelines. The headset may be safely held against the ear of the user. The headset charger shall be installed and used such that parts of the user's body other than the hands are maintained at a distance of approximately 20 cm (8 inches) or more.

This Class B digital apparatus complies with Canadian requirement:
CAN ICES-3 (B)/NMB-3(B).

Appendix

FCC Part 15

Industry Canada

This device complies with Industry Canada licence-exempt RSS standard(s).

Operation is subject to the following two conditions: (1) this device may not cause harmful interference, and (2) this device must accept any interference received, including interference that may cause undesired operation.

Privacy of communications may not be ensured when using this telephone.

The term "IC:" before the certification/registration number only signifies that the Industry Canada technical specifications were met.

This product meets the applicable Innovation, Science, and Economic Development Canada technical specifications

Appendix

California Energy Commission battery charging testing instructions

This cordless headset is set up to comply with the energy-conserving standards right out of the box. These instructions are intended for California Energy Commission (CEC) compliance testing only. When the CEC battery charging testing mode is activated, all headset functions, except battery charging, will be disabled.

If you have registered the cordless headset to the **VH6212** Dongle, below are the testing instructions.

To activate the CEC battery charging testing mode:

1. Unplug the headset charger power adapter from the power outlet. Make sure the headset is plugged with charged battery before proceeding.
2. Press and hold the pair button on the Dongle for about four seconds until the Dongle LED light flashes blue slowly, and then release the button.
3. Immediately press the pair button again. The Dongle LED light will flash blue moderately.
4. Immediately press the pair button once again.

It takes up to one minute to complete the deregistration process. The  LED light alternates slowly in red and blue when the deregistration process is successful.



NOTE: When the headset fails to enter this mode, repeat all the steps mentioned above.

To deactivate the CEC battery charging testing mode:

1. Unplug the headset base power adapter from the power outlet, then plug it back in. The headset base is powered up as normal.
2. Register the headset back to the headset base. See page 46 for headset registration instructions.

If you have registered the cordless headset to a compatible VTech DECT cordless telephone, please refer to the respective user's manual for the activation and deactivation of CEC battery charging testing mode.

If you have registered the cordless headset to a telephone base that does not have CEC battery charging testing mode, all telephone functions on the cordless headset, except battery charging, will be disabled.

Appendix

Limited warranty

1. What does this limited warranty cover?

VTech of this VTech product warrants to the holder of a valid proof of purchase (“CONSUMER” or “you”) that the product and all accessories provided in the sales package (“PRODUCT”) are free from defects in material and workmanship, pursuant to the following terms and conditions, when installed and used normally and in accordance with the PRODUCT operating instructions. This limited warranty extends only to the CONSUMER for products purchased and used in the United States of America and Canada.

2. What will be done if the PRODUCT is not free from defects in materials and workmanship during the limited warranty period (“materially defective PRODUCT”)?

During the limited warranty period, VTech’s authorized service representative will repair or replace at VTech’s option, without charge, a materially defective PRODUCT. If VTech repairs the PRODUCT, they may use new or refurbished replacement parts. If VTech chooses to replace the PRODUCT, they may replace it with a new or refurbished PRODUCT of the same or similar design. VTech will retain defective parts, modules, or equipment. Repair or replacement of the PRODUCT, at VTech’s option, is your exclusive remedy. VTech will return repaired or replacement products to you in working condition. You should expect the repair or replacement to take approximately 30 days.

3. How long is the limited warranty period?

The limited warranty period for the PRODUCT extends for ONE (1) YEAR from the date of purchase. If VTech repairs or replaces a materially defective PRODUCT under the terms of this limited warranty, this limited warranty also applies to repaired or replacement PRODUCT for a period of either (a) 90 days from the date the repaired or replacement PRODUCT is shipped to you or, (b) the time remaining on the original one-year limited warranty; whichever is longer.

Appendix

Limited warranty

4. What is not covered by this limited warranty?

This limited warranty does not cover:

- PRODUCT that has been subjected to misuse, accident, shipping or other physical damage, improper installation, abnormal operation or handling, neglect, inundation, fire, water, or other liquid intrusion; or
- PRODUCT that has been damaged due to repair, alteration, or modification by anyone other than an authorized service representative of VTech; or
- PRODUCT to the extent that the problem experienced is caused by signal conditions, network reliability or cable or antenna systems; or
- PRODUCT to the extent that the problem is caused by use with non-VTech accessories; or
- PRODUCT whose warranty/quality stickers, PRODUCT serial number plates or electronic serial numbers have been removed, altered or rendered illegible; or
- PRODUCT purchased, used, serviced, or shipped for repair from outside the United States of America or Canada, or used for commercial or institutional purposes (including but not limited to products used for rental purposes); or
- PRODUCT returned without a valid proof of purchase (see item 6 on the next page); -or-
- Charges for installation or setup, adjustment of customer controls, and installation or repair of systems outside the unit.

5. How do you get warranty service?

To obtain warranty service in the United States of America, visit **businessphones.vtech.com** or call **1 (800) 595-9511**. In Canada, call **1 (866) 267-7377**.

NOTE: Before calling for service, please review the user's manual; a check of the PRODUCT's controls and features may save you a service call.

Except as provided by applicable law, you assume the risk of loss or damage during transit and transportation and are responsible for delivery or handling charges incurred in the transport of the PRODUCT(s) to the service location. VTech will return repaired or replaced PRODUCT under this limited warranty to you. Transportation, delivery or handling charges are prepaid. VTech assumes no risk for damage or loss of the PRODUCT in transit. If the PRODUCT failure is not covered by this limited warranty, or proof of purchase does not meet the terms of this limited warranty, VTech will notify you and will request that you authorize the cost of repair prior to any further repair activity. You must pay for the cost of repair and return shipping costs for the repair of products that are not covered by this limited warranty.

Appendix

Limited warranty

6. What must you return with the PRODUCT to get warranty service?

You must:

- a. Return the entire original package and contents including the PRODUCT to the service location along with a description of the malfunction or difficulty; and
- b. Include a “valid proof of purchase” (sales receipt) identifying the PRODUCT purchased (PRODUCT model) and the date of purchase or receipt; and
- c. Provide your name, complete and correct mailing address, and telephone number.

7. Other limitations

This warranty is the complete and exclusive agreement between you and VTech of this PRODUCT. It supersedes all other written or oral communications related to this PRODUCT. VTech provides no other warranties for this PRODUCT. The warranty exclusively describes all of VTech’s responsibilities regarding the PRODUCT. There are no other express warranties. No one is authorized to make modifications to this limited warranty and you should not rely on any such modification.

State/Provincial Law rights: This warranty gives you specific legal rights, and you may also have other rights which vary from state to state or province to province.

Limitations: Implied warranties, including those of fitness for a particular purpose and merchantability (an unwritten warranty that the PRODUCT is fit for ordinary use) are limited to one year from date of purchase. Some states/provinces do not allow limitations on how long an implied warranty lasts, so the above limitation may not apply to you. In no event shall VTech be liable for any indirect, special, incidental, consequential, or similar damages (including, but not limited to lost profits or revenue, inability to use the PRODUCT or other associated equipment, the cost of substitute equipment, and claims by third parties) resulting from the use of this PRODUCT. Some states/provinces do not allow the exclusion or limitation of incidental or consequential damages, so the above limitation or exclusion may not apply to you.

Please retain your original sales receipt as proof of purchase.

Appendix

Technical specifications

RF frequency band	1921.536MHz - 1928.448MHz
Channels	5
Operating temperature	32°F - 122°F 0°C - 50°C
Headset charger voltage (AC adapter output)	Output 1: 6VDC @400mA Output 2: 6VDC @300mA
Headset operating voltage	3.2VDC - 4.2VDC
Battery	3.7V 140mAH



Designed to fit you home.
And your life.

VTech Communications, Inc.

A member of THE VTECH GROUP OF COMPANIES.

VTech is a registered trademark of VTech Holdings Limited.

Specifications are subject to change without notice.

© 2017 VTech Communications, Inc.

All rights reserved. 08/17. VH6212_CIB_V1.0