

VXi V300 Quick-Start Guide

Updated 12/20/2016

Part # 204001

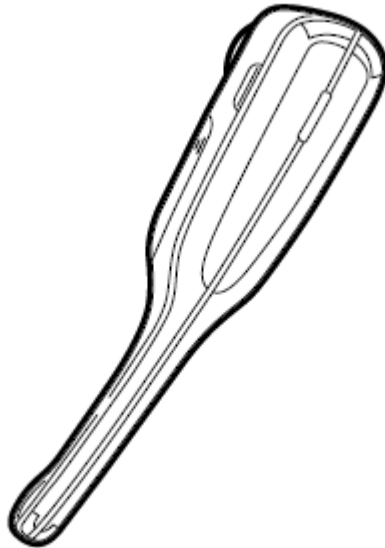
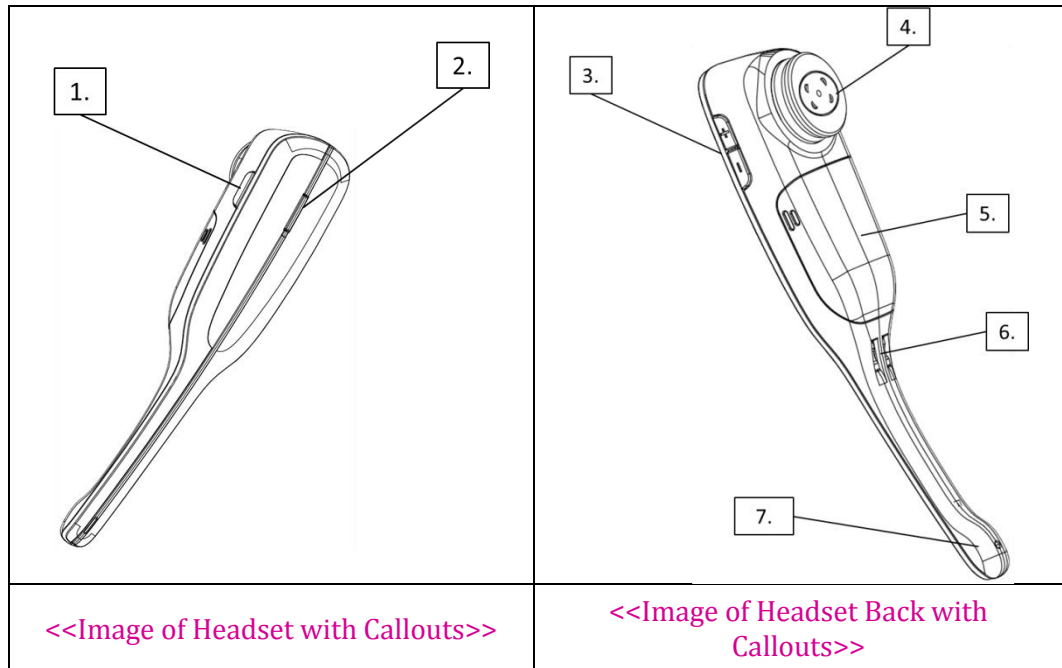

Table of Contents

1. V300 Headset Overview
2. V300 Base Unit Overview
3. Connect to Your Phone, Computer and Cell Phone
 - a. Connect Power to Base
 - b. Install Battery and Charge Headset
 - c. Connect and Configure Phone
 - d. Office Phone
 - e. Analog (Home) Phone
 - f. Connect to a Computer
 - g. Pair to a Cell Phone
 - h. Position Base
4. How to Wear
 - a. Changing Wearing Styles
 - b. Headset Positioning
5. Functions and Indicators Tables

1. Headset Overview

1. Mute
2. Call Control On/Off
3. Volume +/-
4. Earpiece
5. Battery Cover
6. Headset Charging Contacts
7. Microphone



2. Base Overview <<Images of Base –Front, Back, Base. K-Lock Side>>

a. Front

- i. Headset Docking/Charging Cradle
- ii. PC Button/LED
- iii. Phone Button/LED
- iv. Bluetooth Button/LED
- v. Mute LED
- vi. Headset/Bluetooth Pairing Button

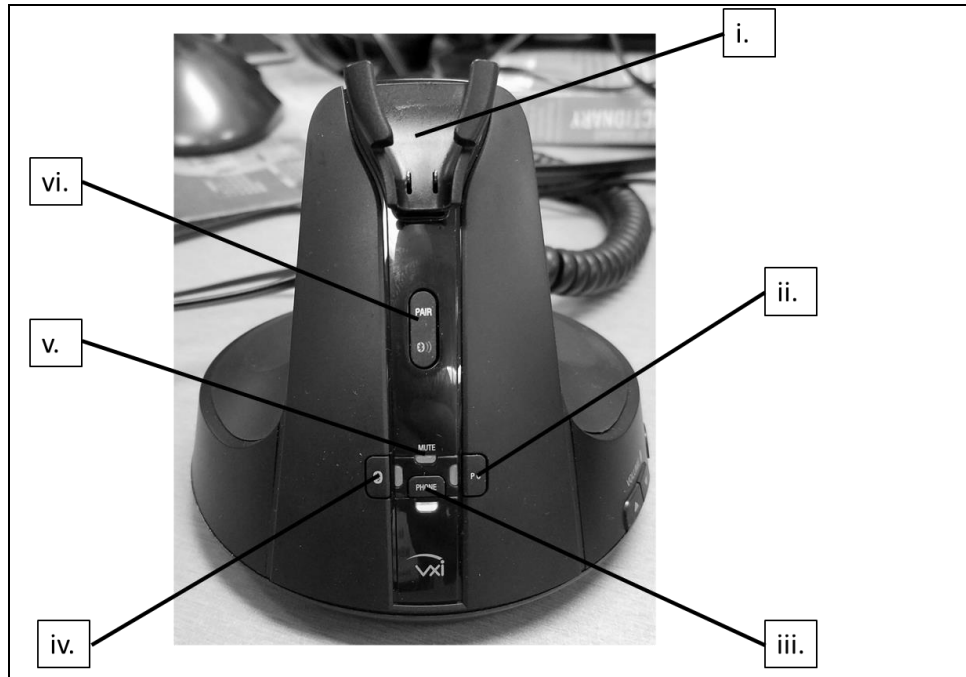

b. Back

- i. Micro-USB Port
- ii. EHS/Lifter Port
- iii. Power Port
- iv. Analog Telephone Port
- v. Base Jack Port
- vi. Handset Port

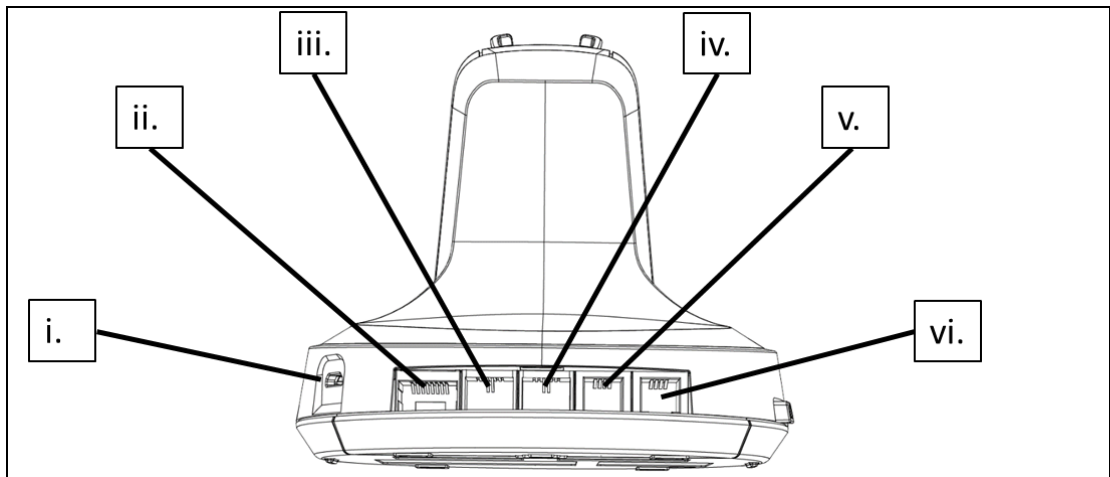

c. Right Side

- i. Headset Microphone Level Adjustment Buttons
- ii. Mode Button
- iii. Micro-USB Port

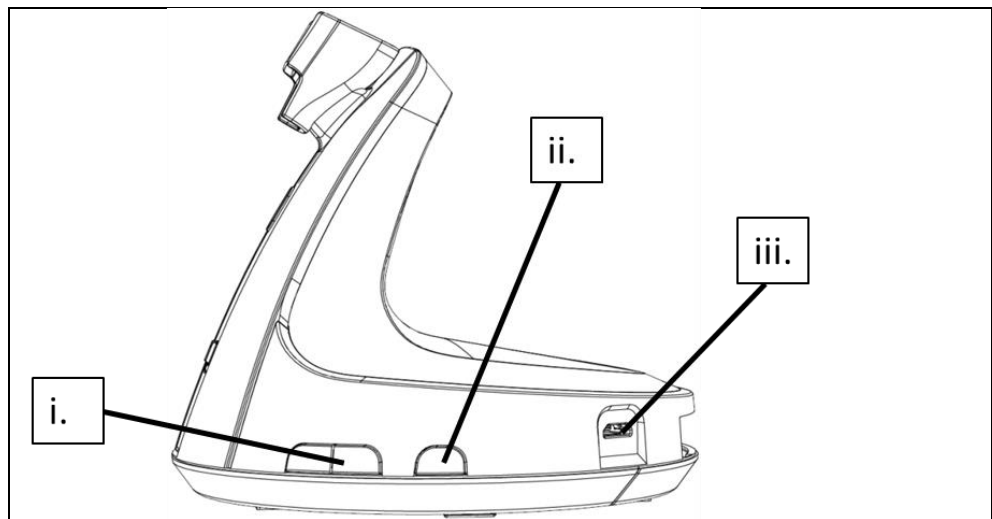

d. **Left Side**

- iv. Phone Compatibility Switch

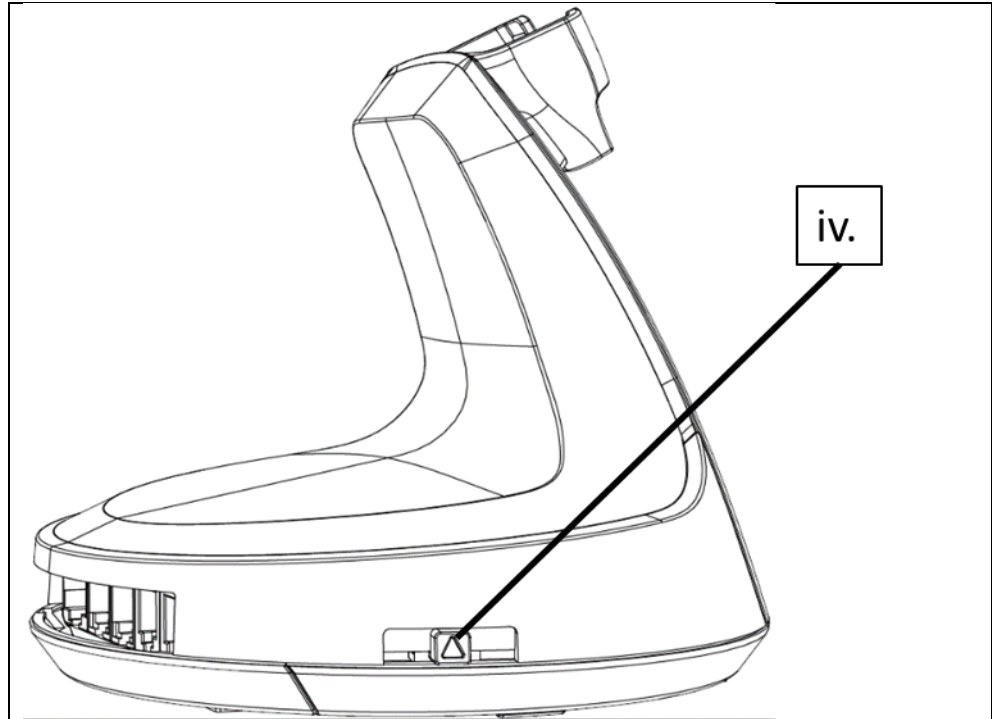

3. Connect to Your Phone, Computer and Cell Phone

a. Connect Power to Base

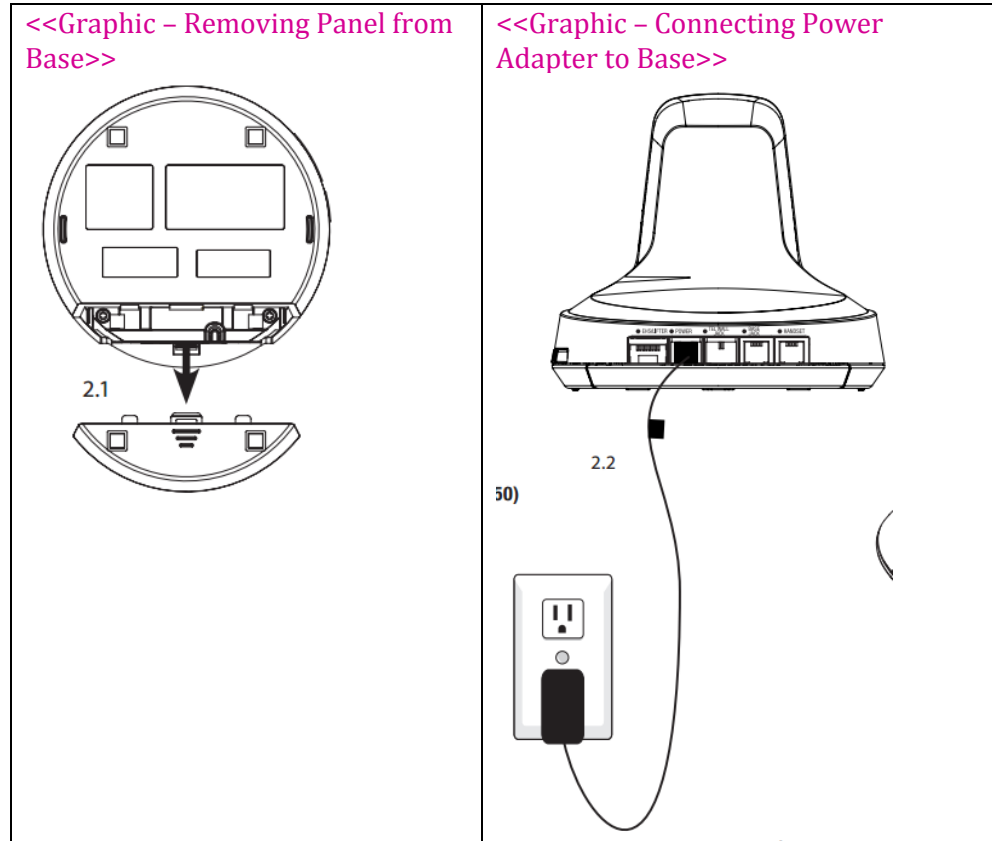

1. Remove the panel from the bottom of the base.
2. Connect the power adapter cable into the base power port (green dot) and plug the power adapter into an electrical socket.

b. Install Battery and Charge Headset

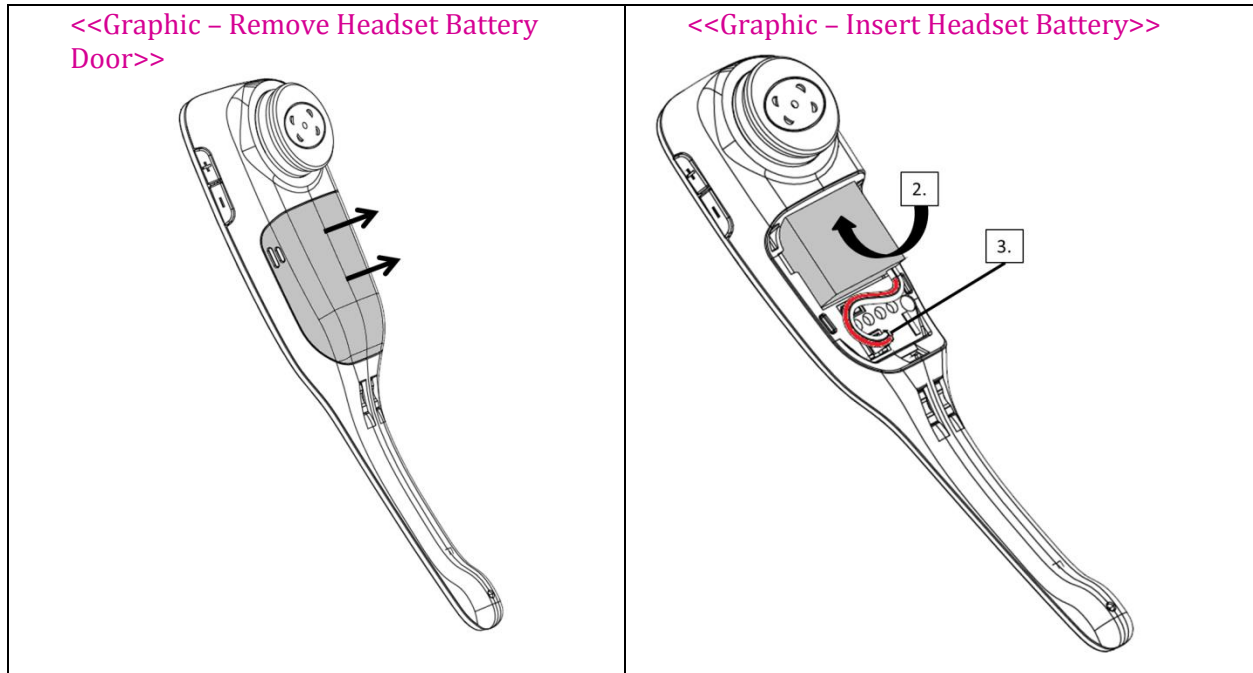

1. Remove the battery cover from the headset.
2. Insert the battery into position with the label “THIS SIDE UP” facing up.
3. Connect the battery lead to the headset.
4. Replace the battery cover and place the headset in the charging cradle. The LED on the headset will be red when charging and will change to blue when the headset is fully charged.

c. Connect and Configure Office Phone

- i. Remove the panel from the bottom of the base.
- ii. Connect the base jack cable (orange flag) to the base jack port (orange dot) on the base and the other end to the headset port of the phone. If you do not have a headset port, you will need to use the handset port.

<<Graphic - Back of Base Unit to Phone Headset Port>>

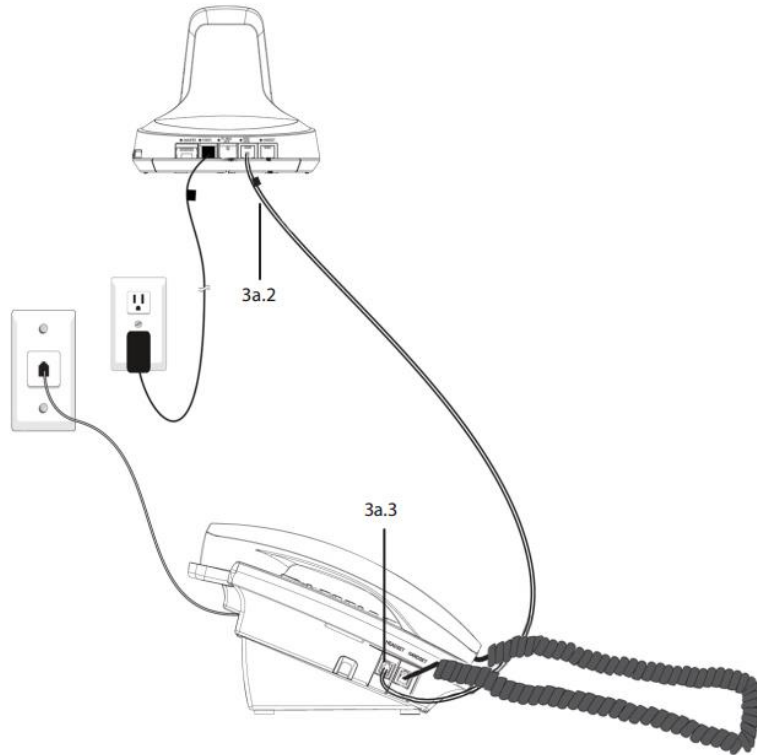

iii. Check Configuration and Make a Test Call:

1. Set your desk phone volume to mid-range.
2. Make sure the base shows the phone output is selected. A green LED indicates the mode is set for office phone use. If it is red, press the mode button on the side of the base to change to the correct mode.
3. Check that the phone compatibility switch on the side of the base is correct for your phone. Most phone makes use setting D (default), but many Cisco phones will use setting A.
4. Open the headset line on your desk phone, or remove the handset from the cradle if you are connected to the handset port.
5. While wearing the headset, press the call control button on the headset.
6. If you do not hear a dial tone (or tones) when pressing the dial pad buttons, try the other base compatibility switch settings until you do.
7. Dial a test call from the desk phone.
 - i. You can fine-tune the earpiece volume using the headset volume buttons.
 - ii. If additional microphone gain (speaking volume) is needed, or if you hear your voice echo in the earpiece (excessive side tone), you can adjust this with the microphone volume buttons on the side of the base.

i. Other Connection Configurations

In addition to the standard setup, there are three more options for setting up the V300 with your phone:

- a. Office Phone with EHS (sold separately)
- b. Office Phone with L50 Lifter (sold separately)
- c. Analog (Home) Phone

For more details, see the full user guide, available online at vxicorp.com/V300.

d. Connect to a Computer

i. Connect USB

1. Plug the small connector on the end of the USB cable provided into the micro USB port on the side of the base.
2. Plug the other end into the USB port on your computer.
3. Wait for your operating system to indicate that it has recognized the headset and that it is ready to use.

ii. Configure Computer Audio Settings

1. Press the PC button on the base. The PC indicator LED will be lit red.
2. Go to your computer's audio settings and make sure that "VXi V300" is selected under both playback and recording.
3. If necessary, make sure the "VXi V300" is also selected for use in your communications software settings.

e. Pair to a Cell Phone

- i. Press the Bluetooth button on the base. The Bluetooth indicator LED will be lit blue.
- ii. Press the call control button on the headset.
- iii. Press the Bluetooth icon at the bottom of the Pair button. You will hear the voice prompt "Ready to Pair" and the blue LED on the Pair button will be flashing fast.
- iv. Open the Bluetooth menu on your device and tell it to search or "scan" for new devices.
- v. Select "VXi V300" to pair the base with your device.
- vi. Successful pairing and connection will be indicated by the voice prompt "Device Connected" and the Bluetooth icon on the Pair button will be lit solid blue.

f. Position Base

To reduce the possibility of noise and interference problems, position the base at least 6 inches away from your desk phone and at least 12 inches away from your computer.

4. How to Wear

a. Changing Wearing Styles

The V300 office wireless headset is supplied with a choice of wearing styles:

1. Ear Hook

- a. Choose the ear bud that fits your ear most comfortably.
- b. Place the ear bud over the post on the ear hook.
- c. Attach the ear hook to the headset by placing it over the earpiece and gently pressing it into position.
- d. Loop the ear hook over the ear and rotate the headset so the microphone is angled toward the mouth.

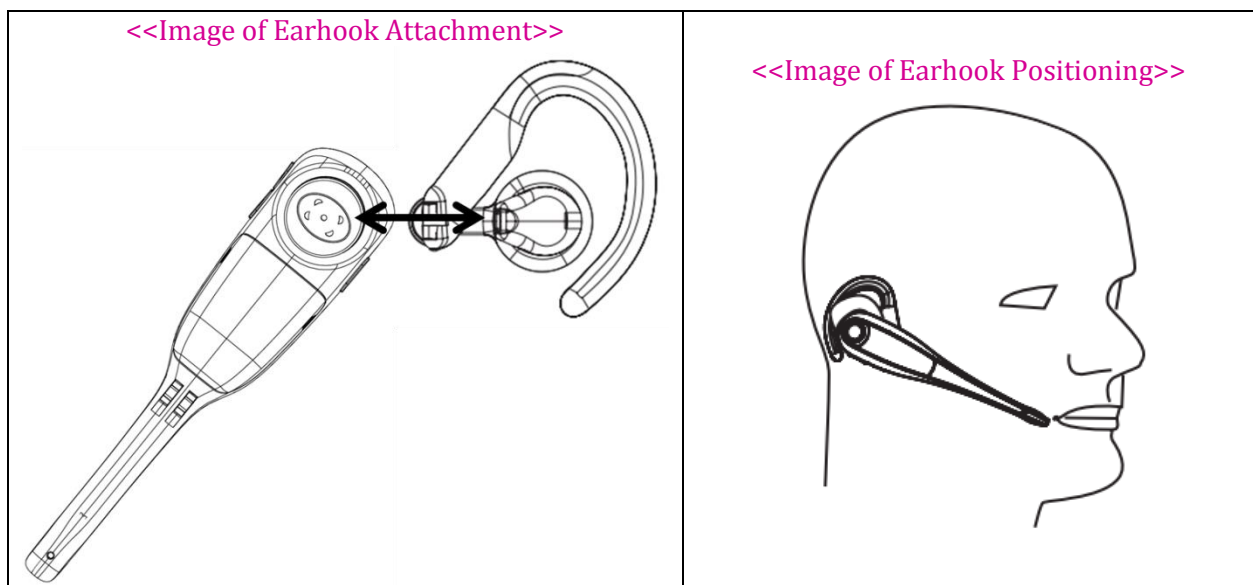

2. Headband

- a. Position the headset earpiece over the headband ring and press until it clicks into place.

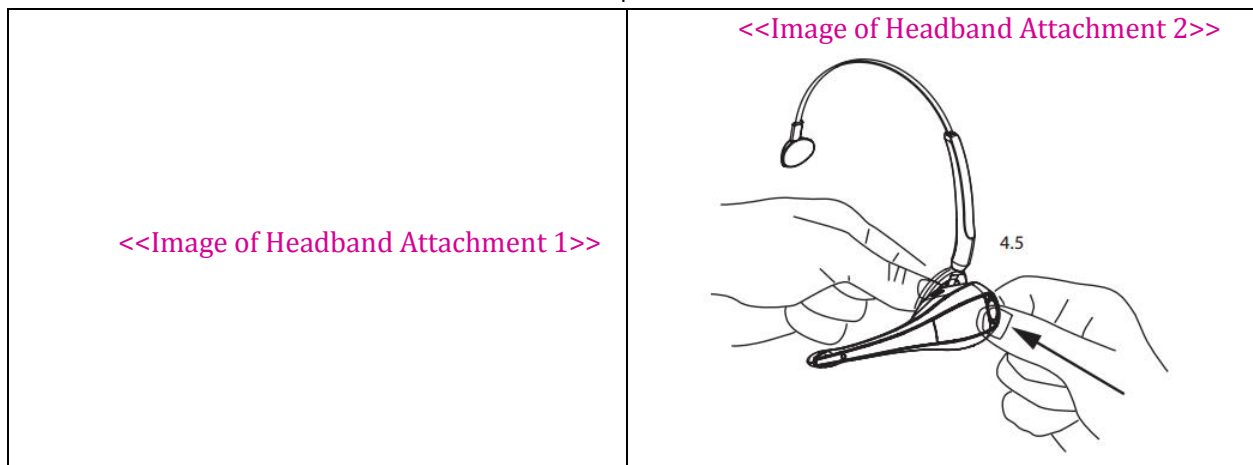

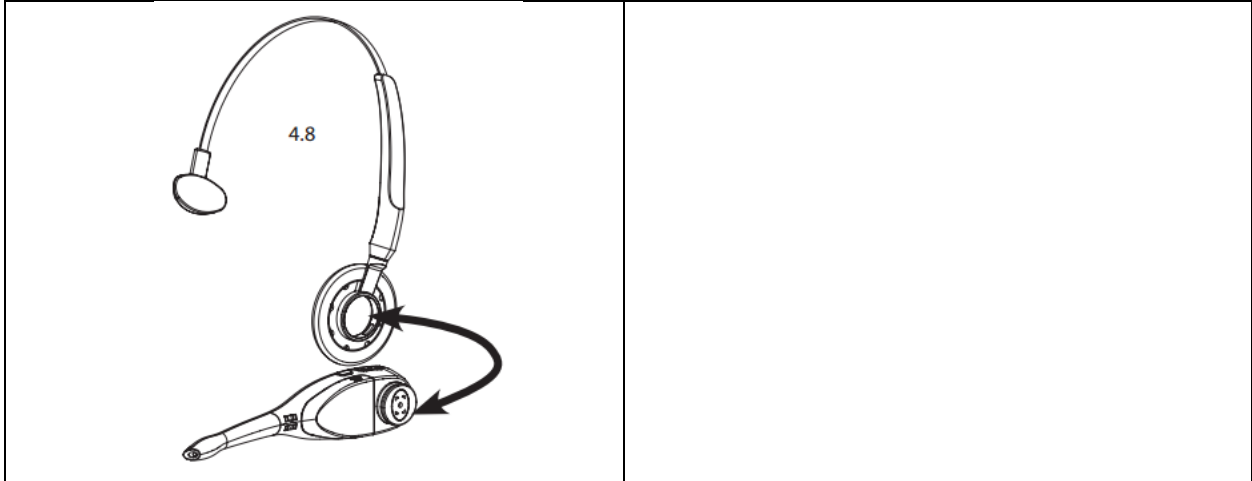

- b. Angle the headset so the microphone boom points towards the corner of the mouth.
- c. Slide the headband in or out to adjust fit.

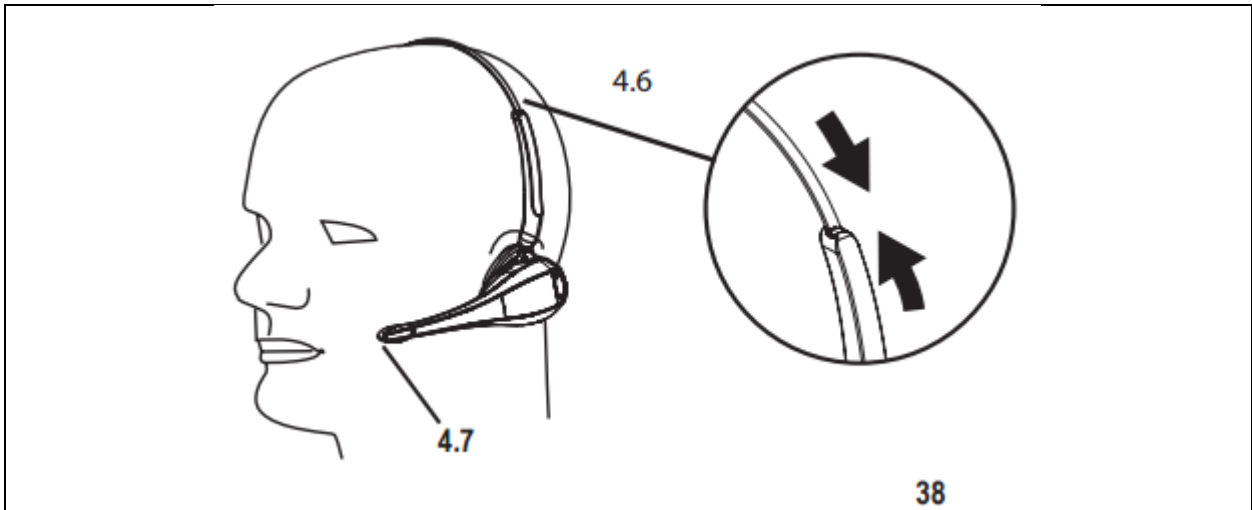

<<Image of Headband Adjustment and Positioning>>

3. Neckband

- a. Position the headset earpiece over the neckband ring and press until it clicks into place

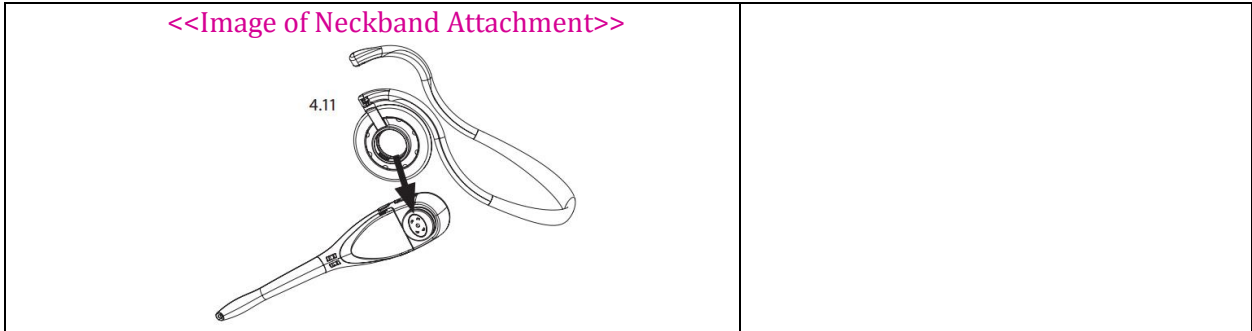

- b. To wear, position the neckband around the back of the neck and over both ears. Angle the microphone boom toward the corner of the mouth.

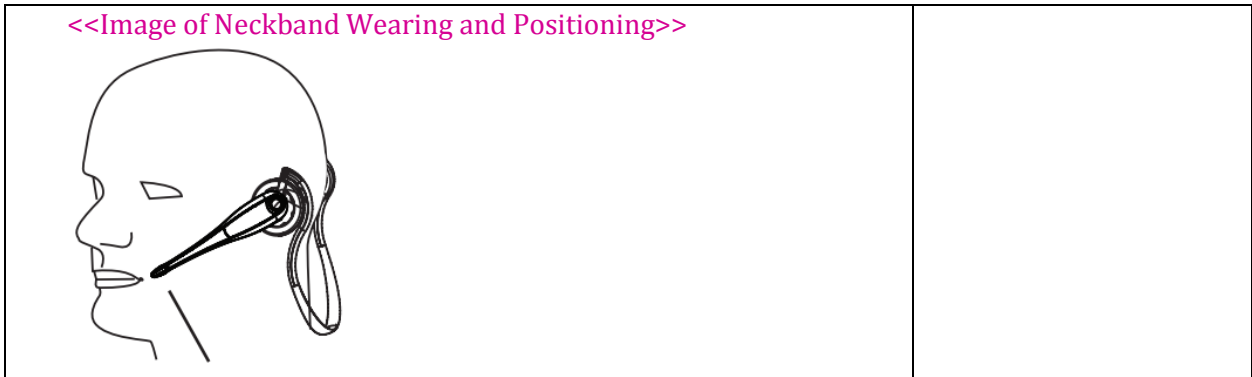

- c. To switch neckband wearing sides, remove the headset from the neckband, and then remove the ring from the neckband arm. Insert the ring post into the bottom hole of the other neckband arm until it clicks into place.

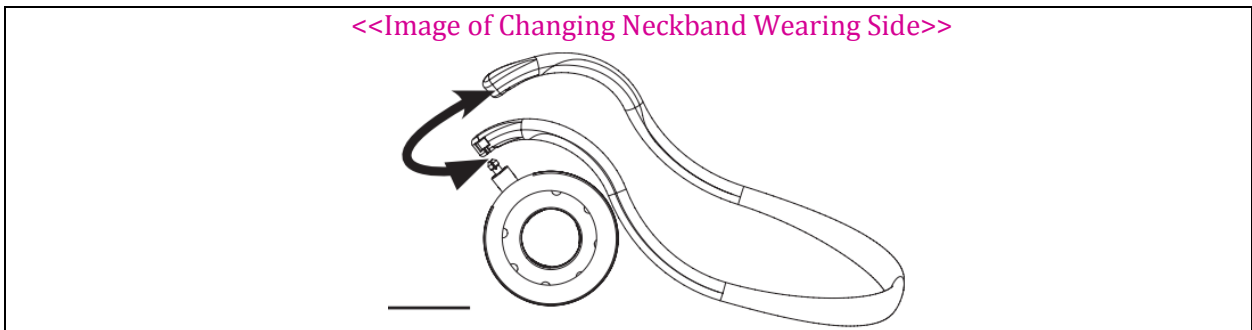

Functions and Indicators Tables

Base

Base/Headset	Function	Button/Duration of Press	Base LED Indicator	Headset LED Indicator	Headset Audio Indicator	Voice Indicator (in English)
Base	PC output path	PC (quick press)	Red PC LED	-	-	-
Base	Phone output path	Phone (quick press)	Green or red Phone LED	-	-	-
Base	Bluetooth output path	Bluetooth (quick press)	Blue Bluetooth LED	-	-	-
Base	Analog phone mode	Mode (quick press)	Red phone LED	-	-	-
Base	Office (digital/VoIP) phone mode	Mode (quick press)	Green phone LED	-	-	-
Base	Pair to a Bluetooth device	Bluetooth Pair (press and hold)	Blue Bluetooth Pair LED (fast flash)	-	-	“Ready to pair”

Headset

Base/Headset	Function	Button/Duration of Press	Base LED Indicator	Headset LED Indicator	Headset Audio Indicator	Voice Indicator (in English)
Headset	Charging in base station	-	-	Red while charging. Blue when charged	-	-
Headset	Volume up	Volume up (quick press)	-	-	1 short tone	-
Headset	Volume down	Volume down (quick press)	-	-	1 short tone	-
Headset	Maximum or minimum volume reached	Volume up or volume down (quick press)	-	-	3 quick beeps	-
Headset	Mute (on/off)	Mute button (quick press)	-	-	-	"Mute on"/ "Mute off"
Headset	Mute reminder	-	Red mute LED	-	1 tone (every 15 seconds)	-
Headset	Answer a call	Call control Button (quick press)	-	Blue light flashes slightly slower	1 short tone	-
Headset	End a call	Call Control Button (quick press)	-	Blue light flashes slightly faster	1 short tone	-
Headset	Out of range	Any headset button	-	-	-	"Out of range"
Headset	Very low battery	-	-	Flashes 3 times, pauses, repeats 3 more times, then shuts down	-	-
Headset	Low battery	-	-	Flashes every 20 seconds	-	"Low battery"
Headset	Incoming call (analog mode)	-	-	Flashes quickly	-	-
Headset	Answer second incoming call (analog mode only)	Mute button (long press)	-	-	1 short tone	-
Headset	Headset not registered	Any headset button press	-	Red and Blue alternating flash	-	"Not registered"

Need More Help?

Technical Support

800-742-8588

www.vxicorp.com/support

Online User Guide

www.vxicorp.com/V300

Boilerplate

<<VXi: The Sound Choice Logo>>

VXi Corporation | 271 Locust Street | Dover, NH 03820 | Toll-free (USA): 800-742-8588 | Phone: +1 603-742-2888 | vxicorp.com

© 2016 VXi Corporation. All rights reserved.

PN 203940/APN 204001X
05/16

Notes
