

Go to [www.vtechphones.com](http://www.vtechphones.com) to register your product for enhanced warranty support and the latest VTech product news.

## VC7017 Accessory Motion Sensor for use with ULE certified systems\*



# vtech® User's manual

\* Visit [www.vtechphones.com/wireless-monitoring](http://www.vtechphones.com/wireless-monitoring) for the latest ULE compatible products.

## Congratulations

on purchasing your new VTech product. Before using this product, please read **Important safety instructions**.

This manual has instructions on how to set up and register your new sensor. For instructions on sensor settings, see the user's manual that came with your ULE compatible products. Visit [www.vtechphones.com/wireless-monitoring](http://www.vtechphones.com/wireless-monitoring) for a list of the latest ULE compatible products.

You may also view or download the online User's manual of the respective product for a full set of installation and operation instructions at [www.vtechphones.com](http://www.vtechphones.com). In Canada, visit [www.vtechcanada.com](http://www.vtechcanada.com).

## Introduction

Stay on top of activity in your home, whether it is unwanted visitors or the kids coming and going. This sensor will let you know when it detects activity.

This Motion Sensor has two types of motion-detection functions: **Pet-Immune Intrusion Detection** (for major motions of adults) and **Occupancy Detection** (for minor motions of adults, babies, or pets).

## What's in the box

Your product package contains the following items. Save your sales receipt and original packaging in the event warranty service is necessary.

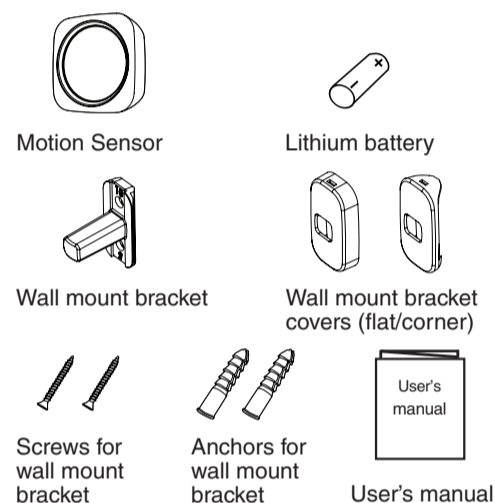

## Motion Sensor overview

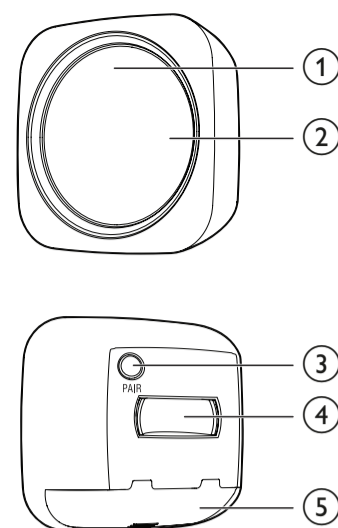

- 1 – Motion detector
- 2 – LED light
  - Green for a half second when the sensor is powered on.
  - Flashes green when the sensor is in the pairing mode.
- 3 – PAIR button
  - Press and hold to enter the pairing mode.
- 4 – Magnetic holder
- 5 – Battery compartment cover

## Before use

### Install Motion Sensor Battery

#### NOTES

- Use only CR123A Lithium Battery.
- When inserting battery, ensure polarities are correct.
- For proper operation, use battery within the following temperature range: 0°F (-18°C) and 120°F (49°C).

1. Slide open battery compartment cover.

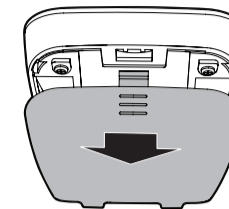

2. Insert the battery into the battery compartment.

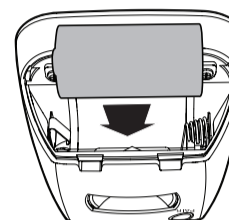

3. Slide the battery compartment cover back until it securely clicks into place.

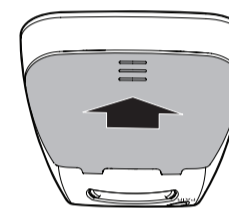

## Add and register a sensor

Your new VC7017 Motion Sensor can be registered to any ULE compatible product. Register each sensor individually to the respective ULE compatible product before use.

### Register a Motion Sensor:

1. Enter the registration mode by selecting the option for adding a sensor in your ULE compatible product. Refer to the user's manual of your ULE compatible product for more detailed instructions.
2. Press and hold the **PAIR** button on the Motion Sensor for 3 seconds, until the LED light at the front side flashes green. The sensor is now registering to the ULE compatible product.

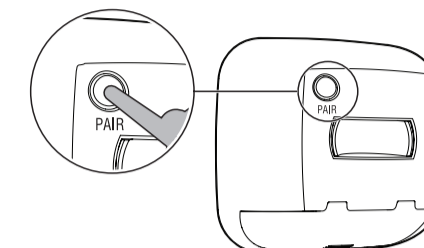

The registration process takes about 90 seconds to complete. When this registration process completes, the LED light on the sensor will remain steadily on for approximately two seconds then, will turn off. If registration fails, remove the battery from the sensor and wait for a few seconds. Then, re-install the battery and wait until the LED light stops flashing. After that, begin registration process again.

#### NOTES

- Make sure you do not press the **PAIR** button again once released after 3 seconds. Otherwise, the sensor will enter the testing mode.
- You can also download online User's manuals at [www.vtechphones.com/support/manuals](http://www.vtechphones.com/support/manuals).

## Replacing a sensor

If you have purchased this new VC7017 accessory sensor to replace an old sensor, you must deregister the registered sensor first, and then register this new sensor to your ULE compatible product.

### Deregister a sensor or all sensors:

- Refer to the User's manual of your ULE compatible products to deregister a sensor or all sensors.

## Motion detection

The Motion Sensor detects motion with one-minute cool off time. Once motion is detected, the sensor will start detecting motion again only after one minute.

**Pet-Immune Intrusion Detection** detects the major motion of a person over several steps of walking, while **Occupancy Detection** detects the relatively minor motions of sedentary occupants such as adults, babies, and pets in a room. Pet-Immune Intrusion Detection is designed to discern humans from small animals, so that the sensor can report movement of persons in locked/unoccupied areas, while allowing pets to roam about such areas without being reported.

The sensor detects motion horizontally within a 90° angle, and vertically within a 48° angle. The detection area covers up to **20 X 20 feet**. For the most complete coverage of a rectangular room, it is recommended to mount the sensor in a corner of the room.

The Motion Sensor should be placed facing away from large windows. To provide the best detection performance, it is recommended to mount the Motion Sensor with its wall mount bracket on the corner or the wall, within one of the two height ranges:

### 8.6 feet (2.6 meters) - 10.6 feet (3.2 meters)

You need to orient the bracket sloping 10° downward (see **Mount the sensor**).

### 6.6 feet (2 meters) - 8.6 feet (2.6 meters)

You need to orient the bracket sloping 5° downward (see **Mount the sensor**).

#### Top View - Corner Mounting

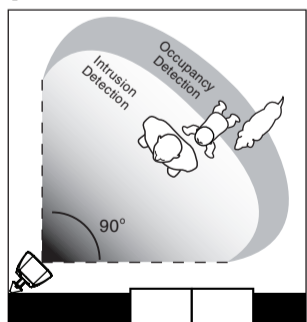

Place the Motion Sensor facing away from large windows.

#### Top View - Corner Mounting

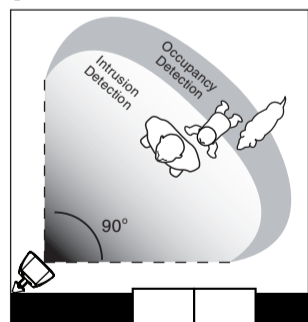

Place the Motion Sensor facing away from large windows.

#### Side View - Flat Wall Mounting

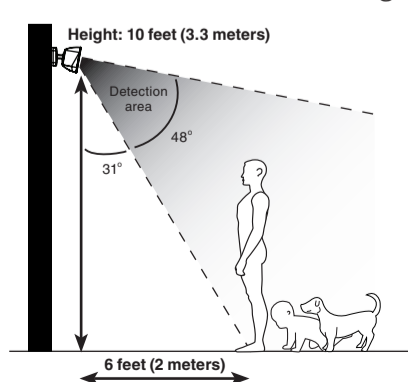

#### Side View - Flat Wall Mounting

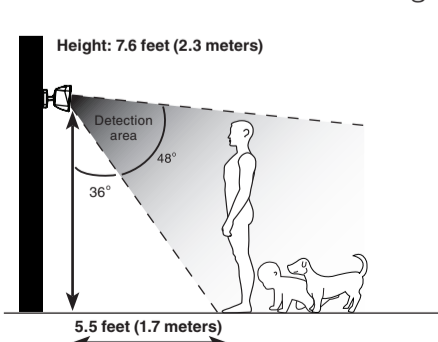

NOTE  
• The numerical values in the illustrations are for conceptual reference only. The actual angles and distances may vary upon the change in the mounted height of the sensor.

## Check the sensor before use

1. Place the sensor about **3.3 feet (1 meter)** from the ULE compatible product.
2. Press and hold the **PAIR** button on the Motion Sensor for 3 seconds.
3. Release and immediately press the **PAIR** button again to enter the test mode until the green LED is steadily on. The test mode will last for 5 minutes.
4. Walk across the area in front of the sensor.
  - The green LED on the sensor will flash.
  - You will receive notifications at your ULE compatible product. Refer to the Installation guide or user's manual of your ULE compatible product for the sensor alerts.

#### NOTES

- Make sure you have done step 3 right after step 2. Otherwise, the sensor will enter the pairing mode.
- In the test mode, once motion is detected, the sensor will only start to detect motion again after 5 seconds.
- In the normal mode, once motion is detected, the sensor will only start to detect motion again after one minute. When you have received alerts already, you will only receive alerts again for motion detected after one minute.

## Test the sensor signal strength

You can mount the Motion Sensor at a location where family members or unwanted visitors are likely to be coming and going.

1. Take the sensor to the desired mounting location and then, temporarily mount it at the desired height (Refer to **Motion detection** section). Use adhesive tape to hold the bracket temporarily in place.
  - If your ULE compatible product has a signal checking or testing mode, enter the respective menu option to test the sensor signal strength.
2. Walk across the area in front of the sensor again and check whether a good signal is received at your ULE compatible product.

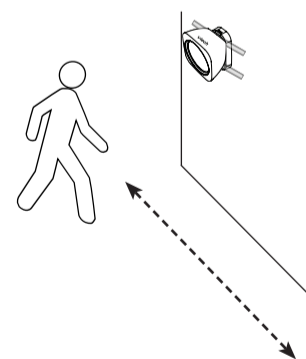

#### NOTES

- Once motion is detected, the sensor will only start to detect motion again after one minute. When you have received alerts already, you will only receive alerts again for motion detected after one minute.
- If there is no alert received when you walk across the area in front of the sensor, move your ULE compatible product closer to the mounting location or move the sensor closer to the respective product.
- Depending on surroundings and obstructing factors, like walls or cabinets, the sensor may not transmit to the ULE compatible product properly.

## Mount the sensor

#### NOTES

- This sensor must be mounted vertically on wall or at a corner. Do not mount the Motion Sensor in a horizontal orientation, or flat on the ceiling.
- Make sure the mounting surface is clean. A textured surface or any imperfections to a smooth surface can keep the mounting tape from making a strong bond.
- This device detects or performs better when provided with a constant and stable environment. Avoid placing the sensor at a location which faces direct sunlight, or exposes to areas that may change temperature rapidly, or where there are air ducts or substantial airflows.
- If you drill the holes into an object other than a stud, insert the screw anchors into the holes and tap gently on the ends with a hammer until the screw anchors are flush with the wall or ceiling.

### Orientation of wall mount bracket:

The wall mount bracket's vertical angle is not perpendicular to the Motion Sensor. According to the mounting height selected, you need to orient the bracket sloping upward (number "5" up) or sloping downward (number "10" up).

| Mounting height                                | Orientation of wall mount bracket                    |
|------------------------------------------------|------------------------------------------------------|
| 8.6 feet (2.6 meters) – 10.6 feet (3.2 meters) | Number "10" up (sensor facing downward at 10° angle) |
| 6.6 feet (2 meters) – 8.6 feet (2.6 meters)    | Number "5" up (sensor facing downward at 5° angle)   |

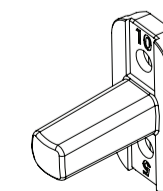

**Mounting height:**  
8.6 feet (2.6 meters) – 10.6 feet (3.2 meters)

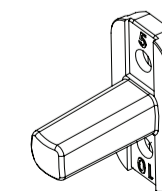

**Mounting height:**  
6.6 feet (2 meters) – 8.6 feet (2.6 meters)

#### NOTES

- For Pet-Immune Intrusion (human-only) Detection, it is better to mount the sensor higher.
- The illustrations used in the mounting steps are with number "10" up in the wall mount bracket.

## Mount on a corner of the wall

1. Place the wall mount bracket on a corner of the wall and then use a pencil to mark the top and the bottom holes as shown. Remove the wall mount bracket and drill two holes in the corner (7/32 inch drill bit).

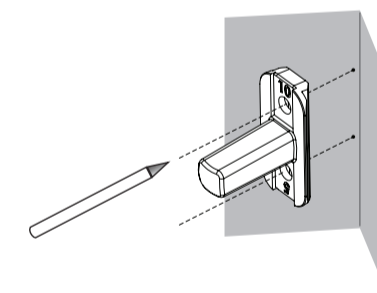

2. If you drill the holes into a stud, go to step 3.

### -OR-

If you drill the holes into an object other than a stud, insert the wall anchors into the holes. Tap gently on the ends with a hammer until the wall anchors are flush with the corner of the wall.

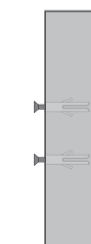

3. Align the wall mount bracket and screws with the holes in the corner of the wall as shown. Tighten the screws so that the wall mount bracket position is fixed.

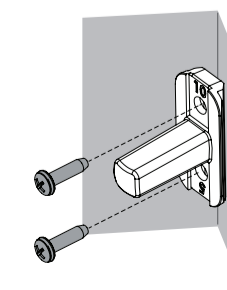

- Push the wall mount bracket cover for corner towards the wall mount bracket, until it securely clicks into place.

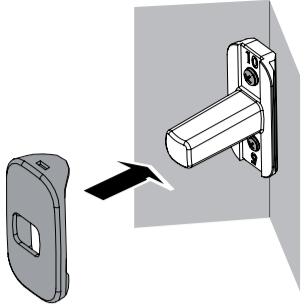

- Holding with the **vtech** logo facing up, hook the Motion Sensor on the wall mount bracket installed, until the magnetic holder and the wall mount bracket are attached firmly.

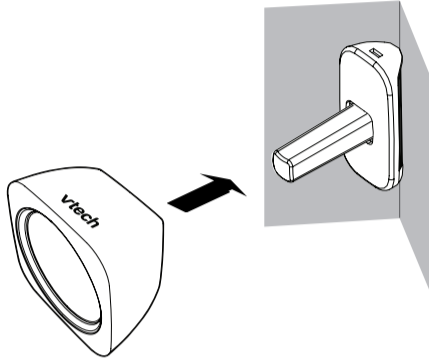

## Mount on the flat wall

- Place the wall mount bracket on a wall and then use a pencil to mark the top and the bottom holes as shown. Remove the wall mount bracket and drill two holes in the wall (7/32 inch drill bit).

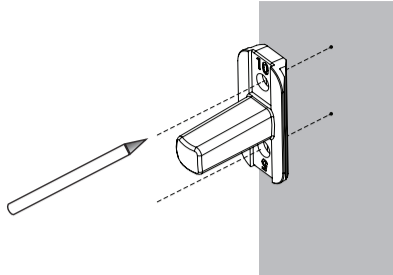

- If you drill the holes into a stud, go to step 3.

**-OR-**

If you drill the holes into an object other than a stud, insert the wall anchors into the holes. Tap gently on the ends with a hammer until the wall anchors are flush with the wall.

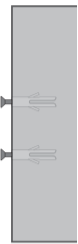

- Align the wall mount bracket and screws with the holes in the wall as shown. Tighten the screws so that the wall mount bracket position is fixed.

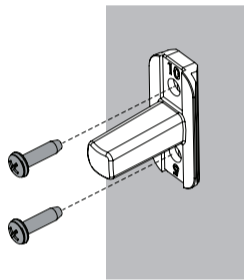

- Push the wall mount bracket cover towards the wall mount bracket, until it securely clicks into place.

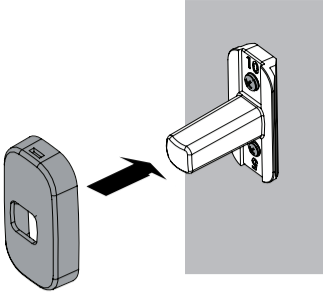

- Holding with the **vtech** logo facing up, hook the Motion Sensor on the wall mount bracket installed, until the magnetic holder and the wall mount bracket are attached firmly.

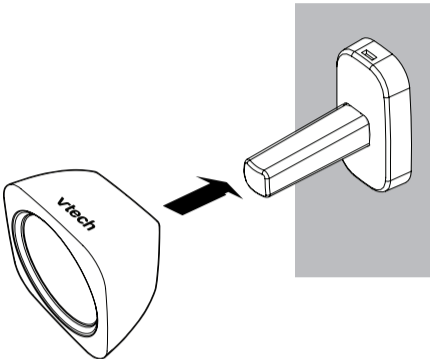

## General product care

### Taking care of your sensor

Your sensor contains sophisticated electronic and optical parts, so it must be treated with care. Avoid touching the sensor's polyethylene front window.

### Avoid rough treatment

Place the sensor down gently. Save the original packing materials to protect your sensor if you ever need to ship it.

### Avoid water

Your sensor can be damaged if it gets wet. Do not use the sensor outdoors in the rain, or handle it with wet hands. Do not install the sensor near a sink, bathtub or shower.

### Electrical storms

Electrical storms can sometimes cause power surges harmful to electronic equipment. For your own safety, take caution when using electrical appliances during storms.

### Cleaning your sensor

Your sensor has a durable plastic casing that should retain its luster for many years. Clean it only with a dry non-abrasive cloth. Do not use dampened cloth or cleaning solvents of any kind. The front window may be wiped gently with 70% isopropyl alcohol on a very soft cloth.

## Storage

When you are not going to use the sensor for some time, remove the battery from the sensor. Store the sensor in a cool and dry place.

## Frequently asked questions

Below are the questions most frequently asked about the sensor. If you cannot find the answer to your question, visit our website at [www.vtechphones.com](http://www.vtechphones.com) or call **1-844-848-8324 (1-844-84-VTECH)** for customer service. In Canada, visit our website at [www.vtechcanada.com](http://www.vtechcanada.com) or call **1-800-267-7377**.

|                                  |                                                                                                                                                                                                                                                                                                                                                                          |
|----------------------------------|--------------------------------------------------------------------------------------------------------------------------------------------------------------------------------------------------------------------------------------------------------------------------------------------------------------------------------------------------------------------------|
| The sensor does not work at all. | Make sure the CR123A lithium battery is installed.<br>The sensor may be deregistered from your ULE-compatible product. Refer to <b>Add and register a sensor</b> and register the sensor back.<br>The sensor may be out of range. Move the sensor closer to your ULE compatible product.<br>The sensor may be upside-down. Make sure the <b>vtech</b> logo is facing up. |
|----------------------------------|--------------------------------------------------------------------------------------------------------------------------------------------------------------------------------------------------------------------------------------------------------------------------------------------------------------------------------------------------------------------------|

(1) this device may not cause harmful interference, and (2) this device must accept any interference received, including interference that may cause undesired operation.

To ensure safety of users, the FCC has established criteria for the amount of radio frequency energy that can be safely absorbed by a user or bystander according to the intended usage of the product. This product has been tested and found to comply with the FCC criteria. The sensor unit shall be installed and used such that parts of all persons' body are maintained at a distance of approximately 8 in (20 cm) or more.

This Class B digital apparatus complies with Canadian requirement:  
CAN ICES-3 (B)/NMB-3(B)

### Industry Canada

This device complies with Industry Canada licence-exempt RSS standard(s).

Operation is subject to the following two conditions:

(1) this device may not cause harmful interference, and (2) this device must accept any interference received, including interference that may cause undesired operation.

The term "IC:" before the certification/registration number only signifies that the Industry Canada technical specifications were met.

This product meets the applicable Innovation, Science and Economic Development Canada technical specifications

### RF radiation exposure statement

The sensor complies with FCC RF radiation exposure limits set forth for an uncontrolled environment. The sensor unit should be installed and operated with a minimum distance of 8 in (20 cm) between the sensor and all persons' body. This transmitter must not be co-located or operating in conjunction with any other antenna or transmitter. This equipment complies also with Industry Canada RSS-102 with respect to Canada's Health Code 6 for Exposure of Humans to RF Fields.

## For C-UL and cETL compliance only

### Mesures de sécurité importantes

Lorsque vous utilisez votre appareil, vous devriez toujours suivre certaines mesures de précaution de base afin de réduire les risques d'incendie, d'électrocution et de blessures corporelles, dont ceux qui suivent :

- L'installation par un adulte est requise.
- Ne placez pas cet appareil sur un chariot, meuble, trépied, support de montage ni table chancelants.

- Les enfants devraient être supervisés afin de vous assurer qu'ils ne jouent pas avec l'appareil.
- Le produit n'est pas conçu pour être utilisé par des personnes (incluant des enfants) aux capacités physiques, sensorielles ou mentales réduites ou qui manquent d'expérience et de connaissances, à moins qu'on leur ait donné suffisamment de supervision ou d'instructions relativement à l'utilisation de l'appareil par une personne responsable de leur sécurité.
- Ne pas utiliser le détecteur de mouvement dans les domaines suivants qui pourraient déformer, défaillance ou défaillance opérationnelle :
  - sous la lumière directe du soleil;
  - les zones exposées à la graisse ou de la vapeur, comme les cuisines;
  - les incendies ou les appareils de chauffage;
  - les zones soumises à des changements des températures extrêmes, comme à côté de climatiseurs;
  - des zones opaques ou objets qui ne reflètent - blocs qui sont nécessaires pour détecter les ondes ir;
  - les zones où la température est affectée par le fort éclairant objets (tels que des lampes halogènes).

### CONSERVEZ CES INSTRUCTIONS

#### Pile

- MISE EN GARDE** : Il peut y avoir un risque d'explosion si vous utilisez le mauvais type de piles pour l'unité du capteur.
- Ne jetez pas la pile au feu. Vérifiez les instructions spécifiques de mise aux rebus auprès des autorités locales.
- N'ouvrez pas et ne mutiliez pas la pile. L'électrolyte qui s'en échapperait est corrosif et pourrait causer des brûlures ou des blessures aux yeux ou à la peau. L'électrolyte est toxique si avalé.
- Soyez prudents lorsque vous manipulez les piles afin d'éviter les courts-circuits provoqués par des matériaux conducteurs.

#### Stimulateurs cardiaques implantés dans l'organisme

Les stimulateurs cardiaques (ne s'applique qu'aux dispositifs numériques sans fil) :

L'organisme Wireless Technology Research, LLC (WTR), une firme de recherche indépendante, a mené une évaluation pluridisciplinaire des interférences entre les téléphones sans fil portatifs et les stimulateurs cardiaques implantés dans l'organisme. Appuyée par l'Administration des aliments et drogues (FDA) des États-Unis, la firme WTR recommande aux médecins:

#### Avis aux détenteurs de stimulateurs cardiaques

- Vous devriez maintenir les dispositifs sans fil à au moins six pouces du simulateur cardiaque.
- Ils ne doivent PAS placer le téléphone sans fil directement sur le stimulateur cardiaque, tel que dans une poche de chemise, lorsque celui-ci est en marche.

L'étude effectuée par l'organisme WRS n'a pas identifié de risque pour les détenteurs de simulateurs cardiaques causés par les gens qui utilisent un téléphone sans fil à proximité de ceux-ci.

## Limited warranty

### What does this limited warranty cover?

The manufacturer of this VTech Product warrants to the holder of a valid proof of purchase ("Consumer" or "you") that the Product and all accessories provided in the sales package ("Product") are free from defects in material and workmanship, pursuant to the following terms and conditions, when installed and used normally and in accordance with the Product operating instructions. This limited warranty extends only to the Consumer for Products purchased and used in the United States of America and Canada.

### What will VTech do if the Product is not free from defects in materials and workmanship during the limited warranty period ("Materially Defective Product")?

During the limited warranty period, VTech's authorized service representative will repair or replace at VTech's option, without charge, a Materially Defective Product. If we repair the Product, we may use new or refurbished replacement parts. If we choose to replace the Product, we may replace it with a new or refurbished Product of the same or similar design. We will retain defective parts, modules, or equipment. Repair or replacement of the Product, at VTech's option, is your exclusive remedy. VTech will return the repaired or replacement Products to you in working condition. You should expect the repair or replacement to take approximately 30 days.

### How long is the limited warranty period?

The limited warranty period for the Product extends for ONE (1) YEAR from the date of purchase. If VTech repairs or replaces a Materially Defective Product under the terms of this limited warranty, this limited warranty also applies to the repaired or replacement Product for a period of either (a) 90 days from the date the repaired or replacement Product is shipped to you or (b) the time remaining on the original one-year warranty; whichever is longer.

### What is not covered by this limited warranty?

This limited warranty does not cover:

- Product that has been subjected to misuse, accident, shipping or other physical damage, improper installation, abnormal operation or handling, neglect, inundation, fire, water or other liquid intrusion; or
- Product that has been damaged due to repair, alteration or modification by anyone other than an authorized service representative of VTech; or
- Product to the extent that the problem experienced is caused by signal conditions, network reliability, or cable or antenna systems; or
- Product to the extent that the problem is caused by use with non-VTech accessories; or
- Product whose warranty/quality stickers, product serial number plates or electronic serial numbers have been removed, altered or rendered illegible; or
- Product purchased, used, serviced, or shipped for repair from outside the United States of America or Canada, or used for commercial or institutional purposes (including but not limited to Products used for rental purposes); or
- Product returned without a valid proof of purchase (see item 2 on the next column); or
- Charges for installation or set up, adjustment of customer controls, and installation or repair of systems outside the unit.

### How do you get warranty service?

To obtain warranty service in the USA, please visit our website at [www.vtechphones.com](http://www.vtechphones.com) or call **1-844-848-8324 (1-844-84-VTECH)**. In Canada, visit at [www.vtechcanada.com](http://www.vtechcanada.com) or call **1-800-267-7377**.

**NOTE:** Before calling for service, please review the user's manual - a check of the Product's controls and features may save you a service call.

Except as provided by applicable law, you assume the risk of loss or damage during transit and transportation and are responsible for delivery or handling charges incurred in the transport of the Product(s) to the service location. VTech will return repaired or replaced Product under this limited warranty. Transportation, delivery or handling charges are prepaid. VTech assumes no risk for damage or loss of the Product in transit. If the Product failure is not covered by this limited warranty, or proof of purchase does not meet the terms of this limited warranty, VTech will notify you and will request that you authorize the cost of repair prior to any further repair activity. You must pay for the cost of repair and return shipping costs for the repair of Products that are not covered by this limited warranty.

## Important safety instructions

When using your equipment, basic safety precautions should always be followed to reduce the risk of fire, electric shock and injury, including the following:

- Adult setup is required.
- Do not place this product on unstable shelves, stands, tables or other surfaces.
- Children should be supervised to ensure that they do not play with the product.
- The product is not intended for use by persons (including children) with reduced physical, sensory or mental capabilities, or lack of experience and knowledge, unless they have been given supervision or instruction concerning use of the appliance by a person responsible for their safety.
- Do not use the motion sensor in the following areas that may cause deformation, malfunction, or operational failure:
  - under direct sunlight;
  - areas exposed to grease or steam, such as kitchens;
  - near fire or heating devices;
  - areas subject to extreme temperature changes, such as next to air conditioners;
  - areas with IR-opaque or reflective objects that can block IR energy that are needed for detection;
  - areas where the temperature is affected by strong illuminating objects (such as halogen lights).

### SAVE THESE INSTRUCTIONS

#### Battery

- CAUTION:** Use only the battery indicated in this manual. There may be a risk of explosion if a wrong type of battery is used for the sensor unit.
- Do not dispose of the battery in a fire. Check with local waste management codes for special disposal instructions.
- Do not open or mutilate the battery. Released electrolyte is corrosive and may cause burns or injury to the eyes or skin. The electrolyte may be toxic if swallowed.
- Exercise care in handling battery in order not to create a short circuit with conductive materials.

### What must you return with the Product to get warranty service?

- Return the entire original package and contents including the Product to the VTech service location along with a description of the malfunction or difficulty; and
- Include a "valid proof of purchase" (sales receipt) identifying the Product purchased (Product model) and the date of purchase or receipt; and
- Provide your name, complete and correct mailing address, and telephone number.

### Other limitations

This warranty is the complete and exclusive agreement between you and VTech. It supersedes all other written or oral communications related to this Product. VTech provides no other warranties for this Product. The warranty exclusively describes all of VTech's responsibilities regarding the Product. There are no other express warranties. No one is authorized to make modifications to this limited warranty and you should not rely on any such modification.

State/Provincial Law Rights: This warranty gives you specific legal rights, and you may also have other rights, which vary from state to state or province to province.

Limitations: Implied warranties, including those of fitness for a particular purpose and merchantability (an unwritten warranty that the Product is fit for ordinary use) are limited to one year from the date of purchase. Some states/provinces do not allow limitations on how long an implied warranty lasts, so the above limitation may not apply to you. In no event shall VTech be liable for any indirect, special, incidental, consequential, or similar damages (including, but not limited to lost profits or revenue, inability to use the Product or other associated equipment, the cost of substitute equipment, and claims by third parties) resulting from the use of this Product. Some states/provinces do not allow the exclusion or limitation of incidental or consequential damages, so the above limitation or exclusion may not apply to you.

### Please retain your original sales receipt as proof of purchase.

### Precautions for users of implanted cardiac pacemakers

Cardiac pacemakers (applies only to digital cordless devices):

Wireless Technology Research, LLC (WTR), an independent research entity, led a multidisciplinary evaluation of the interference between portable wireless devices and implanted cardiac pacemakers. Supported by the U.S. Food and Drug Administration, WTR recommends to physicians that:

#### Pacemaker patients

- Should keep wireless devices at least six inches from the pacemaker.
- Should NOT place wireless devices directly over the pacemaker, such as in a breast pocket, when it is turned ON.

WTR's evaluation did not identify any risk to bystanders with pacemakers from other persons using wireless devices.

## FCC and IC regulations

### FCC Part 15

This equipment has been tested and found to comply with the requirements for a Class B digital device under Part 15 of the Federal Communications Commission (FCC) rules. These requirements are intended to provide reasonable protection against harmful interference in a residential installation. This equipment generates, uses and can radiate radio frequency energy and, if not installed and used in accordance with the instructions, may cause harmful interference to radio communications. However, there is no guarantee that interference will not occur in a particular installation. If this equipment does cause harmful interference to radio or television reception, which can be determined by turning the equipment off and on, the user is encouraged to try to correct the interference by one or more of the following measures:

- Reorient or relocate the receiving antenna.
- Increase the separation between the equipment and receiver.
- Connect the equipment into an outlet on a circuit different from that to which the receiver is connected.
- Consult the dealer or an experienced radio/TV technician for help.

Changes or modifications to this equipment not expressly approved by the party responsible for compliance could void the user's authority to operate the equipment.

This device complies with Part 15 of the FCC rules. Operation is subject to the following two conditions:

## Technical specifications

|                              |                                                                                                                              |
|------------------------------|------------------------------------------------------------------------------------------------------------------------------|
| Frequency control            | Crystal controlled PLL synthesizer                                                                                           |
| Transmit frequency           | 1921.536-1928.448 MHz                                                                                                        |
| Channels                     | 5                                                                                                                            |
| Sensor operating temperature | 0°F (-18°C) to 120°F (49°C)                                                                                                  |
| Nominal effective range      | Maximum power allowed by FCC and IC. Actual operating range may vary according to environment conditions at the time of use. |
| Power requirements           | Battery: Lithium 3V<br>Battery type: CR123A<br>Battery size: 2/3A                                                            |

## Disclaimer

This product is not designed for security purposes. When properly installed and maintained, this product may in some cases reduce the risk of burglary, fire, robbery or other events occurring without providing an alarm. VTech is not responsible for losses, injury, or damage resulting from the use of this product.

This product is covered by U.S. Patent #9,569,953, #9,255,786, #9,301,412, #9,304,044, and #D762,506. Other patents may be pending.



Designed to fit your home.  
And your life.

VTech Communications, Inc.  
A member of THE VTECH GROUP OF COMPANIES.  
VTech is a registered trademark of VTech Holdings Limited.  
Specifications are subject to change without notice.  
Copyright © 2017 for VTech Communications, Inc.  
All rights reserved. 04/17. VC7017\_CIB\_V2.0

