

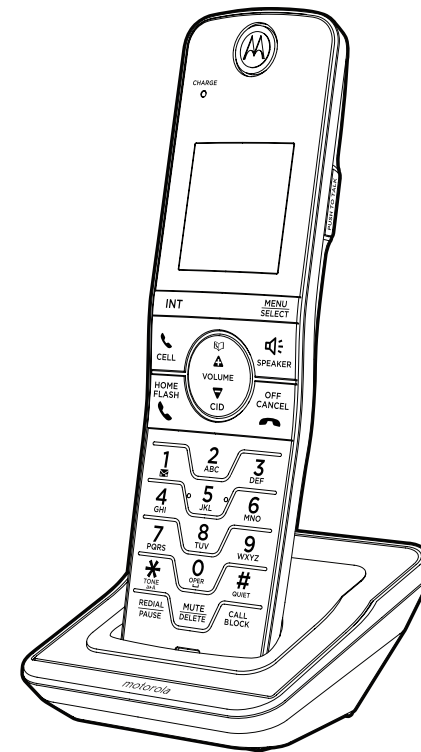

motorola

User's Guide

Cordless Phone with Answering System and Bluetooth
Models: RT802 / RT803 / RT804 / RT803XT / RT804XT / RT805XT

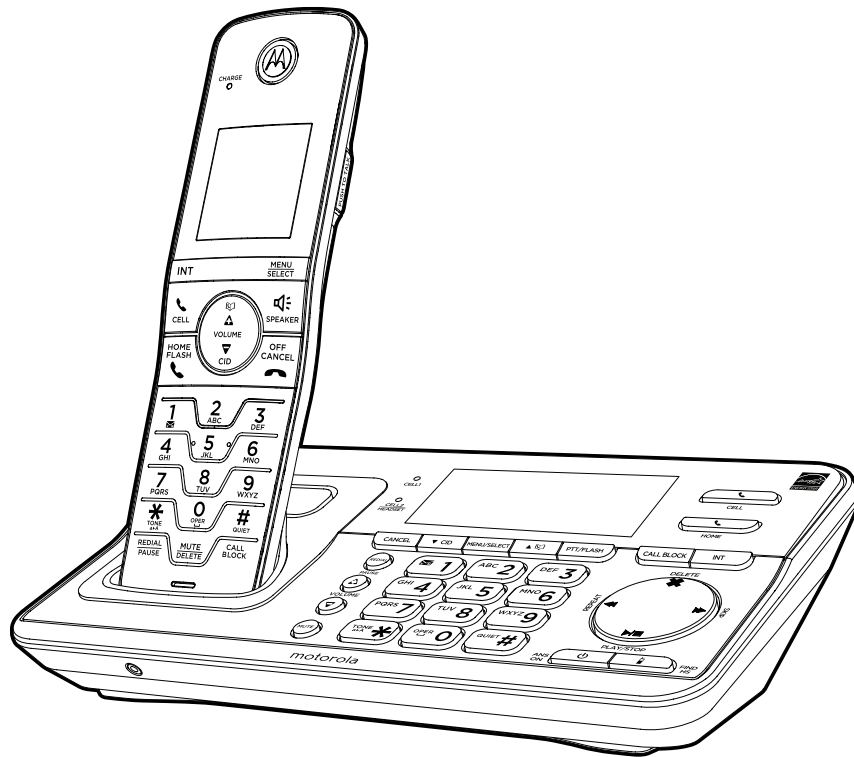



Welcome...

to your new Motorola Phone!

Please retain your original dated sales receipt for your records. For warranty service of your Motorola product, you will need to provide a copy of your dated sales receipt to confirm warranty status. Registration is not required for warranty coverage.

For product-related questions, please call or visit us online:

US and Canada
1-888-331-3383

Email:
support@motorolahome.com

This User's Guide provides you with all the information you need to get the most from your phone.

Before you make your first call you will need to set up your phone. Follow the simple instructions in 'Getting Started', on the next few pages.

IMPORTANT

Only use the adapter and telephone line cord provided in the box.

This equipment is not designed to make emergency telephone calls during power failures. Alternative arrangements should be made for access to emergency services.



Got everything?

- 1000 name and number directory.
- Caller ID shows you who is calling and includes details of the last 50 callers in the caller ID log.**
- Make internal calls, transfer external calls, hold 3-way conversation between two internal callers and an external caller.

** You must subscribe to your network provider's Caller ID or Call Waiting service for these features to work.

Got everything?

- Handset
- Base
- Ni-MH Rechargeable Battery Pack
- Battery Door
- Power Adapter
- Charger
- Telephone Line Cord
- User's Guide

- Quick Start Guide

In multi-handset packs, you will find one or more additional handsets, chargers with power adapter units, additional rechargeable battery packs, and battery doors.



Getting started

Getting started

Connecting the base

Connecting the charger

Mounting the base

Installing and charging the handset battery pack

Setting the display language

Setting the date and time

Getting started

Warning

Do not place your phone in the bathroom or other humid areas.

Location

When choosing a location for your new phone, here are some important guidelines you should consider:

- Avoid sources of noise and heat, such as motors, fluorescent lighting, microwave ovens, heating appliances and direct sunlight.
- Avoid areas of excessive dust, moisture and low temperature.

- Avoid other cordless telephones or personal computers.
- Never install telephone wiring during a lightning storm.
- Never install telephone jacks in wet locations unless the jack is specifically designed for wet locations.
- Never touch non-insulated telephone wires or terminals, unless the telephone line has been disconnected at the network interface.
- Use caution when installing or modifying telephone lines.



Getting started

Handset range

Optimal range is reached when there are no other electrical appliances working within the range area. Any obstruction between the base and handset will also reduce the range significantly.

Signal strength

When out of range of the corded base, the screen shows **Out of range or no pwr at base**. If you are on a call, the line will hang up. Move back within range. The cordless handset will automatically reconnect to the corded base.

Setting up

Important

The base must be plugged into an electrical outlet at all times. Do not connect the telephone line cord to the telephone wall jack until the handset is fully charged. Only use the adapter and telephone line cord supplied with the product.

Connecting the base

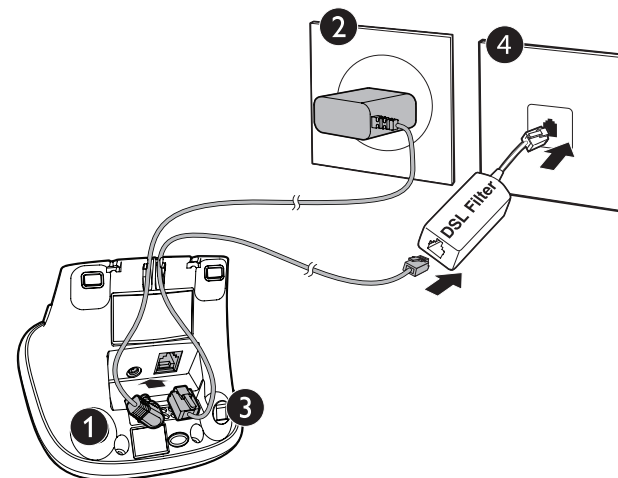

Notes

- In multi-handset packs, the power adapter with the smaller pin is for the charger.
- If you have DSL high-speed Internet service, a DSL filter (not included) is required. Contact your DSL service provider for more information.
- Use only the provided power adapter.
- Steps 3 and 4 should only be done once the handset is fully charged.



Getting started

Connecting the charger

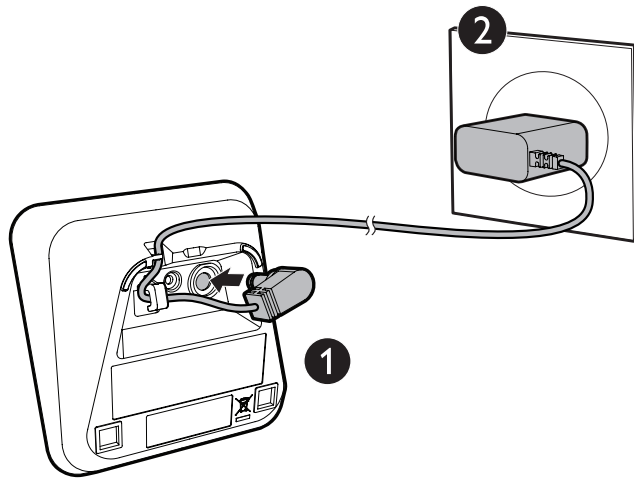

Note

- Make sure the power outlet is not controlled by a wall switch.

Installing and charging the handset battery pack

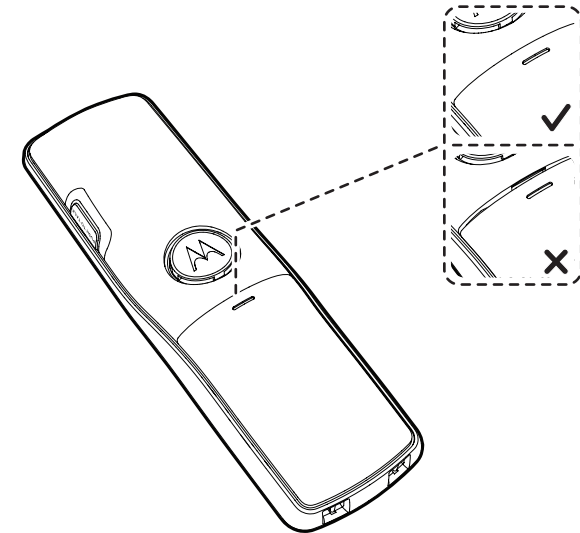
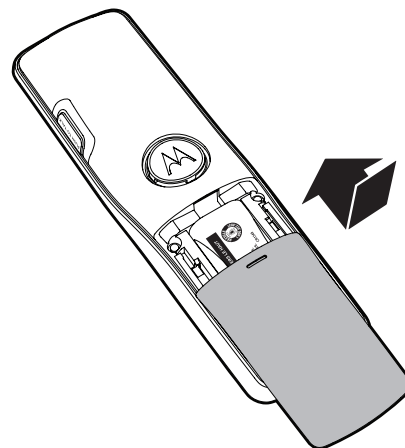
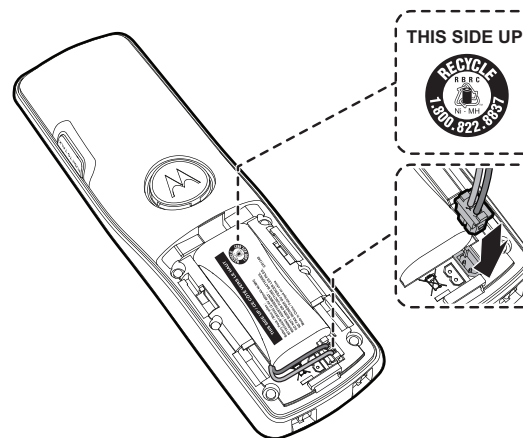

Notes

- Put the handset on the base to charge for at least 12 hours. Once charged, the battery icon  on the the handset LCD will indicate fully charged.

Important

- Use only the rechargeable battery pack provided with the product.



Getting started

Setting the date and time

After you install your phone or power returns following a power outage, the system will prompt you to set the date and time.

Note

- *If you're a subscriber to your network's Caller ID service, the date and time are automatically set when a call is received.*

To set the date and time manually:

1. Press **MENU**.
2. Press **CID/▼** or **▲/☞** to choose **Set date/time**, press **SELECT**.
3. Use the dialing keys (**0-9**) or press **CID/▼** or **▲/☞** to edit the month, day and year. Then press **SELECT**.

4. Use the dialing keys (**0-9**) or press **CID/▼** or **▲/☞** to edit the time in **12 HR** format. Press **CID/▼** or **▲/☞** to toggle **AM/PM** settings or press **2** for AM or **7** for PM.
5. Press **SELECT** to save the settings. There is a confirmation tone and the screen returns to the previous menu.

Setting the display language

The LCD language is preset to English. You can select English, French, or Spanish to be used in all screen displays.

1. Press **MENU**.

2. Press **CID/▼** or **▲/☞** to choose **Settings**, press **SELECT**.
3. Press **SELECT** to choose **LCD Language**.
6. Press **CID/▼** or **▲/☞** to choose the desired language, then press **SELECT**.
7. Press **SELECT** again to confirm. There is a confirmation tone and the screen returns to the previous menu.

Note

- *If you accidentally changed the LCD language to French or Spanish, you can reset it to the English easily by pressing **MENU** and then entering ***364#**.*

Your phone is now ready for use.



Getting started

Getting to know your phone

Overview of your handset

Cordless handset LCD display

Overview of the base

Overview of the charger

Bluetooth

Getting to know your phone

Overview of your handset

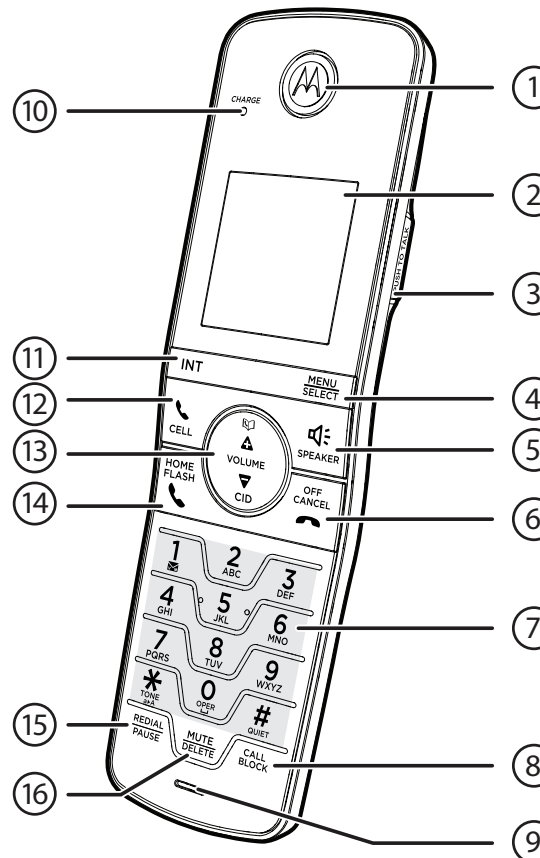

Get acquainted with the following buttons on your handset, and their multi-function tasks.

1. **Receiver**
2. **LCD display**
3. **PUSH TO TALK**
 - Press to initiate a one-to-one or one-to-group broadcast.
 - Press and hold to broadcast to a group of system devices.
4. **MENU/SELECT**
 - Show the menu.
 - While in a menu, press to select an item, or save an entry or setting.



Getting to know your phone

5. **SPEAKER**

- Make or answer a call using the handset speakerphone.
- During a call, press to switch between the speakerphone and the handset.
- Lights on when the handset speakerphone is in use.

6. **OFF/CANCEL**

- Hang up a call.
- Silence the ringer temporarily while the handset is ringing.
- Press and hold to erase the missed call indicator while the phone is not in use.
- While in a menu, press to cancel an operation, return to the previous menu, or exit the menu display; or press and hold to return to idle mode.

7. **1**

- Press repeatedly to add 1 in front of the caller ID log entry before dialing or saving it to the directory.
- Press and hold to set or dial your voicemail number.

TONE/ **TONE/a▶A**

- While you have set the dial mode to pulse and on a call, press to switch to tone dialing temporarily.
- Press to toggle between upper and lower case of the next letters to be input.

0

- Press to add a space when entering names.

#QUIET

- Press and hold to set **Quiet mode** when idle.

- Press repeatedly to show other dialing options when reviewing a caller ID log entry.

8. **CALL BLOCK**

- Press to show the call block menu when the handset is not in use.
- Press to block the incoming call when the phone is ringing.
- When on a call, press to block the call.

9. **Microphone**

10. **CHARGE light**

- On when the handset is charging.



Getting to know your phone

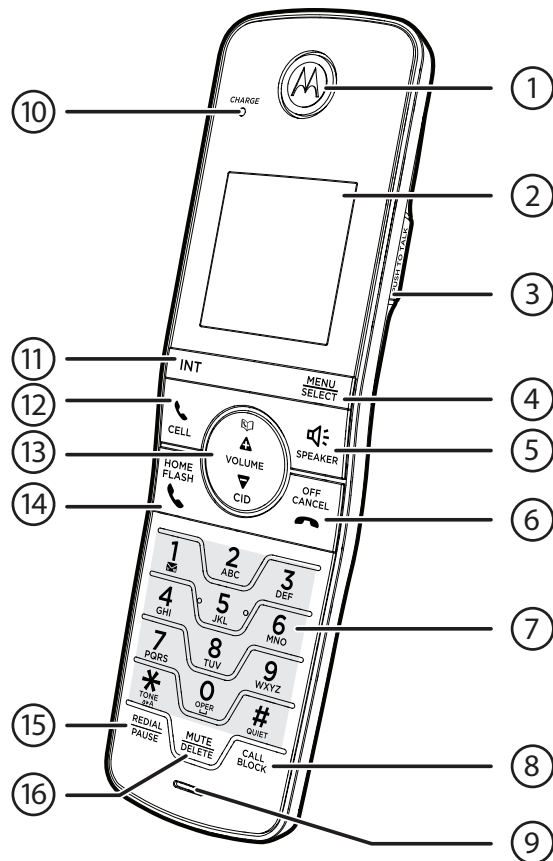

11. INT

- Press to start an intercom conversation or transfer a call (for multi-handset models only).

12. CELL

- Make or answer a cell call.
- Answer an incoming cell call when you hear a call waiting alert.

13. ▲/📖

- Review the directory when the handset is not in use.
- Scroll up while in a menu, or in the directory, caller ID log, or redial list.
- Move the cursor to the right when entering numbers or names.
- Increase the listening volume during a call.

CID/▼

- Review the caller ID log when the handset is not in use.
- Decrease the listening volume during a call.
- Scroll down while in a menu, or in the directory, caller ID log, or redial list.
- Move the cursor to the left when entering numbers or names.

14. HOME/FLASH

- Make or answer a home call.
- Answer an incoming home call when you hear a call waiting alert.
- During message playback, press to call back the caller if the caller's number is available.



Getting to know your phone

15. REDIAL/PAUSE

- Press repeatedly to review the redial list.
- Press and hold to insert a dialing pause while entering numbers.

16. MUTE/DELETE

- Mute the microphone during a call.
- Silence the ringer temporarily while the handset is ringing.
- Delete digits or characters while using the dialing keys.
- Delete the displayed entry while reviewing the directory, caller ID log, redial list, allow list, call block list, or star name list.

Cordless handset LCD display

Display icons

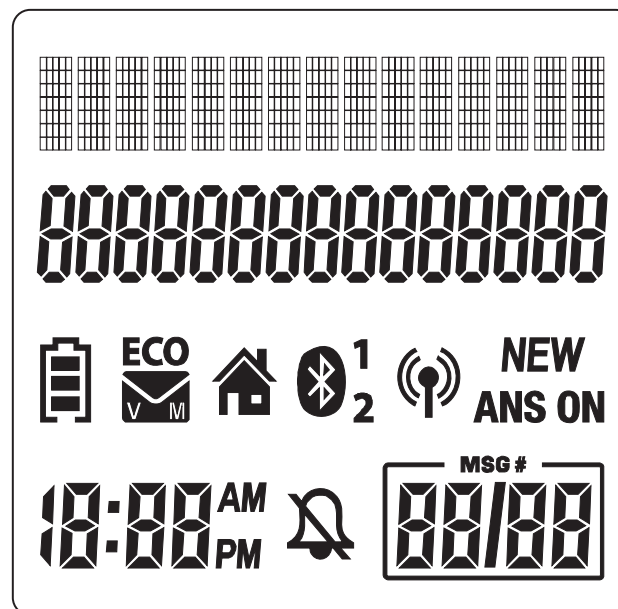

	<p>On when the cell line is in use or there is an incoming cell call.</p> <p>Flashes when there is an incoming cell waiting call.</p>
	<p>There are new voicemail received from your telephone service provider</p>
	<p>The handset ringer is off.</p>
<p>NEW</p>	<p>There are new caller ID log entries.</p>



Getting to know your phone

ECO	The ECO mode activates automatically to reduce power consumption when the handset is within range from the telephone base.
ANS ON	The answering system is turned on.
	Full battery power level.
	2/3 battery power level.
	1/3 battery power level.

	Flashes when the battery is low and needs charging.
	Animation in cycle. Battery is charging.
	In idle mode, the current time is displayed. In Caller ID mode, the time of the call is displayed.

	Flashes when there is a call waiting. On when the home line is in use or there is an incoming home call.
	There are Bluetooth devices connected on the cell devices list.
	The message number currently playing and total number of new/old messages recorded.



Getting to know your phone

Overview of the base

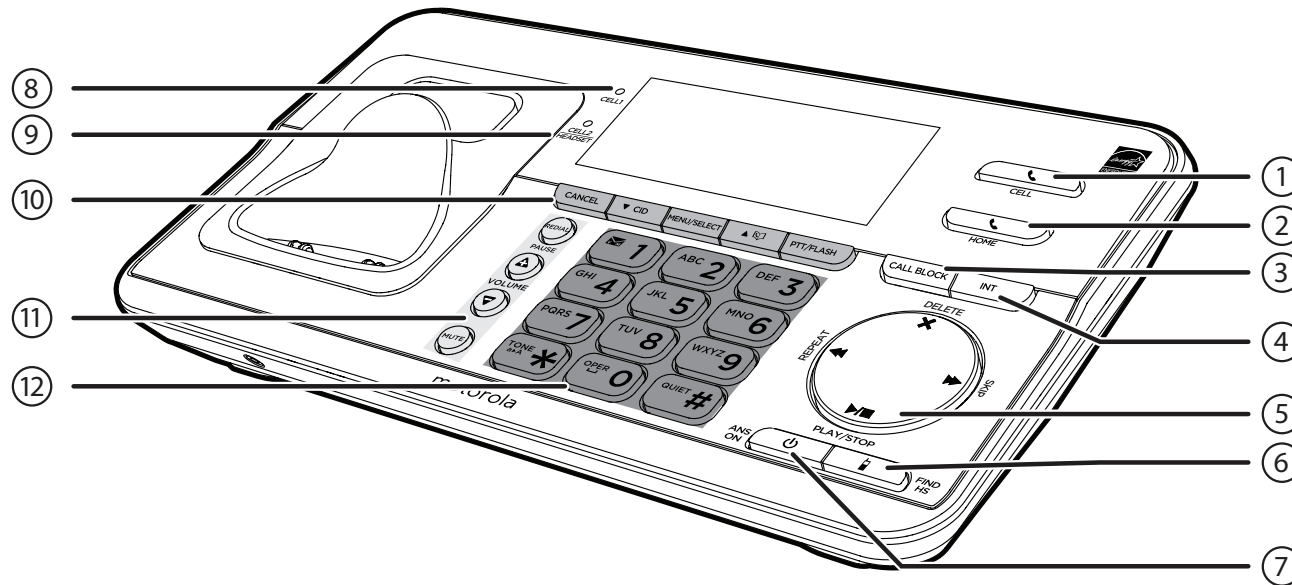

1. CELL

- Make or answer a cell call.
- Answer an incoming cell call when you hear a call waiting alert.

2. HOME

- Make or answer a home call.
- Answer an incoming home call when you hear a call waiting alert.

3. CALL BLOCK

- Press to show the call block menu when the handset is not in use.
- Press to block the incoming call when the phone is ringing.
- When on a call, press to block the call.

4. INT

- Press to start an intercom conversation or transfer a call (for multi-handset models only).

5. DELETE X

- Delete digits or characters while using the dialing keys.
- Delete the displayed entry while reviewing the directory, caller ID log, redial list, allow list, call block list, or star name list.



Getting to know your phone

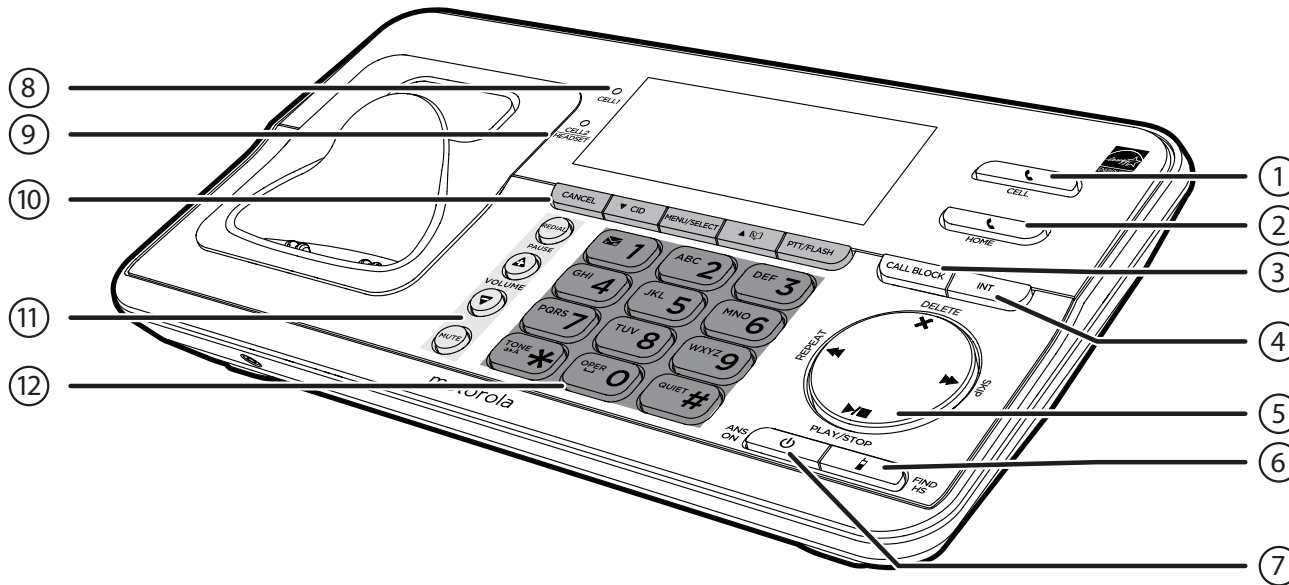

REPEAT

- Press to repeat the playing message during playback.
- Press twice to play the previous message during playback.

SKIP

- Press to skip a message.

PLAY / STOP

- Press to start or stop message playback.

6. FIND HS

- Press to page all system handsets.

7. ANS ON

- Press to turn the built-in answering system on or off.

8. CELL 1 light

- On when the telephone base is paired with a Bluetooth device.
- Flashes when the telephone base is in a discoverable mode.

9. CELL 2 / HEADSET light

- On when the telephone base is paired with a Bluetooth device.
- Flashes when the telephone base is in a discoverable mode.



Getting to know your phone

10. CANCEL

- Silence the ringer temporarily while the handset is ringing.
- Press and hold to erase the missed call indicator while the phone is not in use.
- While in a menu, press to cancel an operation, return to the previous menu, or exit the menu display; or press and hold to return to idle mode.

CID/▼

- Review the caller ID log when the handset is not in use.
- Scroll down while in a menu, or in the directory, caller ID log, or redial list.
- Move the cursor to the left when entering numbers or names.

MENU/SELECT

- Show the menu.
- While in a menu, press to select an item, or save an entry or setting.



- Review the directory when the handset is not in use.
- Scroll up while in a menu, or in the directory, caller ID log, or redial list.
- Move the cursor to the right when entering numbers or names.

PTT/FLASH

- Press to initiate a one-to-one or one-to-group broadcast.
- Press and hold to broadcast to a group of system devices.

- Answer an incoming home call when you hear a call waiting alert.
- During message playback, press to call back the caller if the caller's number is available.

11. REDIAL/PAUSE

- Press repeatedly to review the redial list.
- Press and hold to insert a dialing pause while entering numbers.

VOLUME

- While in idle mode, press to adjust the base ringer volume.
- When on a call, press to adjust the listening volume.
- During message playback or call screening, press to adjust the listening volume.



Getting to know your phone

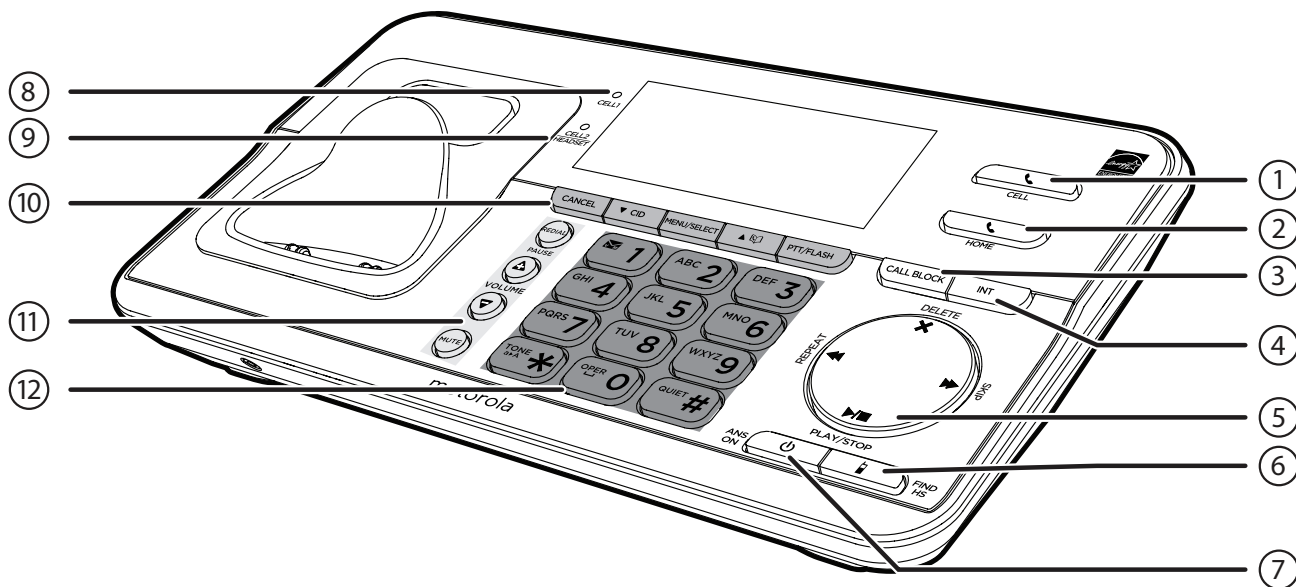

PHONE

- While you have set the dial mode to pulse and on a call, press to switch to tone dialing temporarily.

- Press to toggle between upper and lower case of the next letters to be input.

0 OPER

- Press to add a space when entering names.

#QUIET

- Press and hold to set **Quiet mode** when idle.
- Press repeatedly to show other dialing options when reviewing a caller ID log entry.

MUTE

- Mute the microphone during a call.
- Silence the ringer temporarily while the handset is ringing.

12. 1

- Press repeatedly to add 1 in front of the caller ID log entry before dialing or saving it to the directory.
- Press and hold to set or dial your voicemail number.









Getting to know your phone

Cordless handset LCD display



Display icons

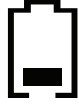
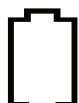

	<p>On when the cell line is in use or there is an incoming cell call.</p> <p>Flashes when there is an incoming cell waiting call.</p>
---	---

	There are new voicemail received from your telephone service provider
	The handset ringer is off.
NEW	There are new caller ID log entries.
ECO	The ECO mode activates automatically to reduce power consumption when the handset is within range from the telephone base.

ANS ON	The answering system is turned on.
	Full battery power level.
	2/3 battery power level.
	1/3 battery power level.
	Flashes when the battery is low and needs charging.
	Animation in cycle. Battery is charging.



	<p>In idle mode, the current time is displayed.</p> <p>In Caller ID mode, the time of the call is displayed.</p>
	<p>Flashes when there is a call waiting.</p> <p>On when the home line is in use or there is an incoming home call.</p>

	<p>There are Bluetooth devices connected on the cell devices list.</p>
	<p>The message number currently playing and total number of new/old messages recorded.</p>

Overview of the charger

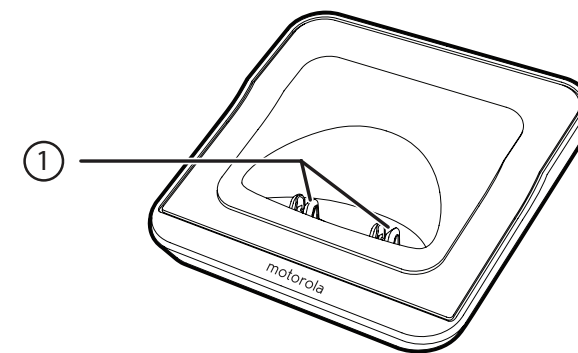

1. **Charging cradle**



Getting to know your phone

Bluetooth

Your **RT802/RT803/RT804/RT803XT/RT804T/RT805XT** phone system with Bluetooth wireless technology has the following features:

- Pair and connect up to a maximum of two cell phones with the telephone base to make and receive cell calls. Only one cell phone can be active on a call at a time.
- Make and receive calls using your cell phone plan while utilizing the ease and comfort of your home telephone system.
- Receive directory entries from your cell phone.

IMPORTANT INFORMATION

- Refer to the user's manual of your Bluetooth enabled cell phone for more information about how that device uses Bluetooth connectivity.
- Bluetooth wireless technology operates within a short range (a maximum of approximately 15 feet) from the telephone base. Keep connected cell phones within this range. For optimal performance, place your cell phone next to the telephone base while using the **RT802/RT803/RT804/RT803XT/RT804T/RT805XT** cell line.

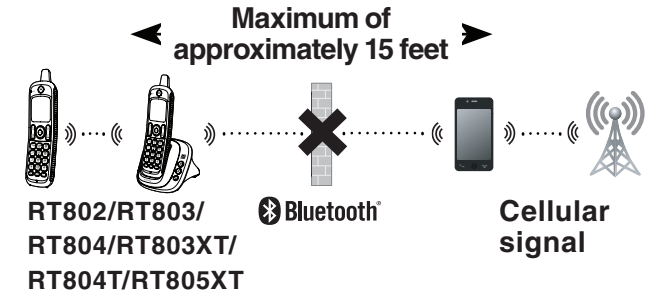

The Bluetooth® word mark and logos are owned by Bluetooth SIG, Inc. and any use of such marks by Motorola Mobility Holdings Limited is under license. Motorola Mobility Holdings Limited is a member of Bluetooth SIG, Inc. Other trademarks and trade names are those of their respective owners.



Getting to know your phone

- If your cell phone has poor reception in your home, the **RT802/RT803/RT804/RT803XT/RT804T/RT805XT** cannot improve the reception. However, if there is a location in your house with better reception, you can leave your cell phone at that location while using the **RT802/RT803/RT804/RT803XT/RT804T/RT805XT** cell line.
 - If you experience poor sound quality, place your cell phone closer to the **RT802/RT803/RT804/RT803XT/RT804T/RT805XT** to ensure strong Bluetooth signal strength. Make sure there are no physical obstacles between the **RT802/RT803/RT804/RT803XT/RT804T/RT805XT** and the cell phone, such as large furniture or thick walls.
 - Charge your cell phone while it is connected to the telephone base. Your cell phone's battery will discharge faster while it is connected to the telephone base via Bluetooth wireless technology.
 - Monitor your cell phone's usage because minutes are deducted from your cellular plan for the duration of all cell calls.
- Refer to Bluetooth setup to learn how to set up and manage your Bluetooth enabled devices. Refer to Telephone operation on how to operate your Bluetooth devices with your new **RT802/RT803/RT804/RT803XT/RT804T/RT805XT** telephone system with Bluetooth wireless technology. Refer to Help if you experience difficulty using the telephone system.

Bluetooth Setup

Note

- *Make sure your cell phone has a good cell reception near the telephone base.*

To use a Bluetooth enabled cell phone with your **RT802/RT803/RT804/RT803XT/RT804T/RT805XT**, you must first pair and connect it with the telephone base. All **RT802/RT803/RT804/RT803XT/RT804T/RT805XT** handsets can be used to make or answer on the cell phone line.

Bluetooth wireless technology operates within a short range (15 feet). When you pair a Bluetooth cell phone to the telephone base, move closer to the telephone base to maintain sufficient signal strength.



Getting to know your phone

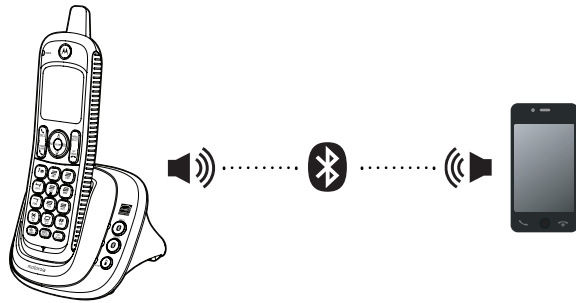

Notes

- For optimal performance, place your cell phone next to the telephone base while using the cell line.
- To avoid interference from other electronic devices, place your telephone base far away from devices such as baby monitors, wireless routers, microwaves, and computers.

Add a Bluetooth enabled cell phone

To pair and connect a cell phone:

1. Choose a slot to pair the cell phone. Press and hold **Ⓜ CELL 1** and/or **Ⓜ CELL 2** on the telephone base for about four seconds until the **Ⓜ CELL 1** and/or **Ⓜ CELL 2** light flashes.
 - If there is already a cell phone in the slot, the existing cell phone will be erased from the cell devices list.
2. Turn on the Bluetooth feature of your cell phone. Once your cell phone finds your phone (**Motorola XT801/XT801/XT811/XT831**), press the appropriate key on your cell phone to continue the pairing process.

- Your cell phone may prompt you to enter the PIN of the telephone base. The default PIN of the telephone base is **0000**.
- All cell phones that are connected to the telephone base are disconnected temporarily until the pairing process is complete.

When the cell phone is successfully paired and connected to the telephone base, the corresponding status icon (**Ⓜ₁** or **Ⓜ₂**) displays. The corresponding device light (**Ⓜ CELL 1** and/or **Ⓜ CELL 2**) turns on.

The pairing process may take up to one minute. If the pairing process fails, turn off the Bluetooth feature on your cell phone and on the **RT802/RT803/RT804/RT803XT/RT804T/RT805XT** by pressing



Getting to know your phone

ⓧ CELL 1/ ⓧ CELL 2. Then repeat the steps above to pair and connect again. In some cases, it may take you a few attempts to complete the pairing process.

The steps for the pairing process may vary for different cell phones. If this happens, follow the prompts on your cell phone and your **RT802/RT803/RT804/RT803XT/RT804T/RT805XT** to complete the pairing process.

Add a Bluetooth enabled headset

To pair and connect a headset:

1. Press **MENU** on the phone when it is not in use.
2. Press **CID/▼** or **▲/☞** to choose **Bluetooth**, and then press **SELECT**.

3. Press **CID/▼** or **▲/☞** to choose **Add BT headset**, and then press **SELECT**. The screen displays **Search headset...**
 - If there is already a cell device in the slot, the existing cell phone will be erased from the cell devices list.

4. Set your headset to discoverable mode (refer to the user's manual of your headset on the Bluetooth feature of your headset). Once your handset finds your headset, press **SELECT**.
 - Enter the PIN of your headset if required. The PIN for most Bluetooth devices is **0000** (refer to the user's manual of your headset), then press **SELECT**.

5. When the headset is successfully paired and connected to the telephone base, the **ⓧ₂** icon displays. The **ⓧ CELL 2** device light turns on.

The pairing process may take up to one minute. If the pairing process fails, turn off the Bluetooth feature on your headset and on the **RT802/RT803/RT804/RT803XT/RT804T/RT805XT** by pressing **ⓧ CELL 2**. Then repeat the steps above to pair and connect again. In some cases, it may take you a few attempts to complete the pairing process.

When a connected headset is charging, it may disconnect from the telephone base and the **ⓧ CELL 2** light on the telephone



Getting to know your phone

base turns off. For some headset models, you may need to turn on the headset and reconnect it to the telephone base again.

Auto connection

A cell device may be disconnected from the telephone base when:

- The Bluetooth feature of your connected cell device is turned off.
- The power of your cell device is turned off.
- Your cell device is not within range of the telephone base.

After the cell device is disconnected, wait for about 1 minute. Then, power on the cell device, turn on the Bluetooth feature, or move it within range

of the base, the base will try to reconnect to the cell device. If you disconnect the cell device from the cell devices list, the base will not attempt to reconnect unless your cell device is moved out of range and back in range again.

Note

- *If your cell device does not reconnect to the base automatically, follow the section below to connect it manually.*

Connect a paired cell phone or headset

If you need to connect your paired cell phone or headset to the telephone base manually:

1. Press **ⓧ CELL 1** and/or **ⓧ CELL 2** on the telephone base when it is not in use. The **ⓧ CELL 1** and/or **ⓧ CELL 2** light flashes.

2. When the cell phone or headset is connected to the telephone base, you hear two beeps. The corresponding status icon (**ⓧ¹** or **ⓧ₂**) displays. The corresponding device light (**ⓧ CELL 1** and/or **ⓧ CELL 2**) turns on.

Disconnect a paired cell phone or headset

If you need to disconnect a paired cell phone or headset from the telephone base, refer to the user's manuals of your cell phone or headset for instructions to disconnect a Bluetooth device.



Getting to know your phone

If you press and hold **CELL 1** and/or **CELL 2** on the telephone base, the existing paired cell phone in that slot will be erased. See **Add a Bluetooth enabled cell phone** and **Add a Bluetooth enabled headset** on how to pair and connect a new cell phone or headset.

Review the cell devices list

1. Press **MENU** on the handset when it is not in use.
2. Press **CID/▼** or **▲/☰** to choose **Bluetooth**, and then press **SELECT**.
3. Press **CID/▼** or **▲/☰** to choose **Device list**, and then press **SELECT**.

Download directory contacts

You can download directory entries to your **RT802/RT803/RT804/RT803XT/RT804T/RT805XT** telephone system via Bluetooth wireless technology. Each downloaded directory are stored in the handset directory with up to 24 digits for each phone number and 15 characters for each name.

Before downloading the directory, make sure the cell phone is paired and connected to the **RT802/RT803/RT804/RT803XT/RT804T/RT805XT**. Make sure the handset battery is charged for at least 10 minutes.

Place your cell phone next to the telephone base while downloading.

To download contacts from your Bluetooth cell phone:

1. Press **MENU** on the handset when it is not in use.
2. Press **CID/▼** or **▲/☰** to choose **Bluetooth**, and then press **SELECT**.
3. Press **CID/▼** or **▲/☰** to choose **Download dir**, and then press **SELECT**. The handset displays **Select a device** briefly.
 - If there is no cell phone paired to the system, the handset displays **Pair cell first** and then returns to the previous menu.



Getting to know your phone

4. Press **CID/▼** or **▲/☞** to choose a desired device when necessary, and then press **SELECT**.

- If the selected device is not available, the handset displays **DX not avail** and then returns to the previous menu.

During the download, the handset flashes

Downloading...

All other idle system handsets display **Downloading...**

5. When the downloading process completes or when the memory is full, the handset displays **Entries added: XXX**. Then the handset returns to the Bluetooth menu.

Notes

- *Certain cell phones do not support SIM card download. If this is the case, try transferring the contacts from your SIM card to your cell phone memory first, and then download from your cell phone memory. For more information on how to transfer contacts from your SIM card to your cell phone memory, see the user's manual of your cell phone.*
- *When downloading the directory from your Bluetooth enabled cell phone, some data may not transfer. For example, if you have home, mobile and work numbers for a particular contact, the three categories may not transfer to your **RT802/RT803/RT804/RT803XT/RT804T/RT805XT**.*



Using the phone

Using the phone

Making a home call

Making a cell call

Answer a home call

Answer a cell call

End a home call

End a cell call

Speakerphone

Volume control

Mute

Join a call in progress

Call waiting on the home line

Call waiting on the cell line

Chain dialing

Find handset

Intercom

Redial list

Directory

Caller ID

Call block



Sound settings

Other settings

Using the phone



Making a home call

Predial

Enter the phone number and then press **HOME**  or **SPEAKER**  to dial the phone number.

- The handset displays **Unable to call** if the telephone line is in use.

Direct dialing



Press **HOME**  or **SPEAKER**  to get a line and enter the phone number.

- The handset displays **Unable to call** if the telephone line is in use.





Using the phone

Dialing from the directory

1. Press .
2. Press **CID/▼** or **▲/📖** to scroll and select the entry you want to dial.
3. Press **HOME**  or **SPEAKER**  to dial the number.

Dialing from the redial list

1. Press **REDIAL**, and then **CID/▼** or **▲/📖** to scroll and select an entry you want to redial.
2. Press **HOME**  or **SPEAKER**  to dial the number.

Dialing from the caller ID log

1. Press **CID** and then **CID/▼** or **▲/📖** to select the entry you want to dial.

2. Press **HOME**  or **SPEAKER**  to dial the number.



Making a cell call

Predial

Enter the phone number and then press **CELL**  to dial the phone number.

- If you have only one cell phone connected to the telephone base, it is automatically selected to make cell calls.
- If you have two cell phones connected to the telephone base, the handset displays **Select a device**. Press **CID/▼** or **▲/📖** to select a cell phone and then press **SELECT**.



Direct dialing

1. Press **CELL** . The handset displays **Select a device**.
 - If you have only one cell phone connected to the telephone base, press **SELECT** to select the only device.
 - If you have two cell phones connected to the telephone base, press **CID/▼** or **▲/📖** to select a cell phone and then press **SELECT**.
2. Enter the telephone number, and then press **CELL**  to dial.
 - The handset displays **Unable to call** if your cell phone is in use.



Using the phone

Dialing from the directory

1. Press .
2. Press **CID/▼** or **▲/📖** to scroll and select the entry you want to dial.
3. Press  **CELL** to dial the number.

Dialing from the redial list

1. Press **REDIAL**, and then **CID/▼** or **▲/📖** to scroll and select an entry you want to redial.
2. Press  **CELL** to dial the number.

Dialing from the caller ID log

1. Press **CID** and then **CID/▼** or **▲/📖** to select the entry you want to dial.
2. Press  **CELL** to dial the number.

Transfer a call from a handset to a Bluetooth headset

When you make or answer a home call or a cell call on a handset, you can transfer the call to your headset. The handset remains active, but the handset earpiece and microphone are muted. If you hang up the handset, the call will end.

1. During a call, press **MENU** on the handset.
2. Press **CID/▼** or **▲/📖** to choose **Use Headset**, and then press **SELECT**.

- The handset briefly displays **Transferring**, followed by **Headset Used** after the call is successfully transferred to the Bluetooth headset.

Notes

- When you answer a call from the headset, that call cannot be transferred to a handset.
- The handset will not show **Use Headset** when the Bluetooth headset is already in use, or there are no active Bluetooth headsets on the device list.

Transfer a call from a headset back to the handset

1. Press **MENU** on the handset.
2. Press **SELECT** to select **Use Handset**.



Note

- When you answer a call using a headset, and you lose the Bluetooth connection or battery is depleted, the call will be lost.





Using the phone

Answer a home call

Press **HOME** , **SPEAKER**  or any dialing key (**0-9**, **✕TONE/a▶A** or **#QUIET**) to answer.

Answer a cell call

Press **CELL** , **SPEAKER**  or any dialing key (**0-9**, **✕TONE/a▶A** or **#QUIET**) to answer.

End a home call

Press **OFF** on the handset, place the handset in the telephone base or handset charger.

End a cell call

Press **OFF** on the handset, place the handset in the telephone base or handset charger.

Speakerphone

When the handset is on a call, press **SPEAKER**  to switch between the speakerphone and the handset receiver. When the speakerphone is active, the handset displays **Speaker**.

Volume control

During a call, press **CID/▼** or **▲/📖**.

Notes

- *The handset and speakerphone volume settings are independent.*
- *When the volume reaches the minimum or maximum setting, you hear two beeps.*

Mute

The mute function allows you to hear the other party but the other party cannot hear you.

During a call, press **MUTE**. The handset displays **Muted** until the mute function is turned off.

Press **MUTE** again to resume the conversation. The handset briefly displays **Microphone on**.

Join a call in progress

Another handset can join you on a home call. That call continues until all parties hang up. You can share an outside call with up to two handsets at the same time.

Join a call

1. When a handset is already on a call, press **HOME**  or **SPEAKER**  on another handset to join the call.





Using the phone

2. Press **CANCEL** or place the handset in the telephone base or handset charger to exit the call. The call continues on the other handset until both handsets hang up.

Call waiting on the home line

When you subscribe to call waiting service with your telephone service provider, the handset flashes  and you hear a beep if someone calls while you are already on a call.

Press **HOME**  on the handset to put your current call on hold and take the new call.

Press **HOME**  on the handset at any time to switch back and forth between calls.

Call waiting on the cell line

When you subscribe to call waiting service with your cell phone service provider, the handset flashes  and you hear a beep if someone calls while you are already on a call.

Press **CELL**  on the handset to put your current call on hold and take the new call.

Press **CELL**  on the handset at any time to switch back and forth between calls.

Chain dialing

Use this feature to initiate a dialing sequence from numbers stored in the directory, caller ID log, or redial list while you are on a call.

Chain dialing can be useful if you wish to access other numbers (such as bank account numbers or access codes) from the directory, caller ID log, or redial list.

Access a number from the directory while on a call

1. Press **MENU**.
2. Press **SELECT** to choose **Directory**.
3. Press **CID/▼** or **▲/📖** to scroll to the desired entry.
4. Press **SELECT** to dial the displayed number.

Access a number from the caller ID log while on a call

1. Press **MENU**.



Using the phone

2. Press **CID/▼** or **▲/☰** to choose Caller ID log, and then press **SELECT**.
3. Press **CID/▼** or **▲/☰** to scroll to the desired entry.
4. Press **SELECT** to dial the displayed number.

Access a number from the redial list while on a call

1. Press **REDIAL** to enter the redial list.
2. Press **CID/▼** or **▲/☰** or **REDIAL** repeatedly to browse to the desired entry.
3. Press **SELECT** to dial the displayed number.



Find handset

This feature helps you find misplaced handsets.

Start the paging tone

- Press **FIND HS**  on the telephone base. All idle handsets ring and their screens display **** Paging ****.

Stop the paging tone

- Press **HOME** , **CELL** , **OFF/CANCEL**, **SPEAKER**  or any dialing key (**0-9**, **✕ TONE/a▶A** or **#QUIET**) on a handset.

-OR-

- Press **FIND HS**  again on the telephone base.

-OR-

- Place the handset in the telephone base or charger.



Intercom

Use the intercom feature for conversations between two devices. Your telephone base supports up to five devices. You can buy additional expansion handsets (**XT8**) or headsets for this telephone base.

1. Press **INT** when idle.
-OR-
Press **MENU** when idle. Press **CID/▼** or **▲/☰** to scroll to **Intercom**, then press **SELECT**.
- The screen displays **Intercom to:**
2. Use the dialing keys to enter a handset number (**1-5**).
- The handset shows **Calling HS X**. The destination handset rings and shows **HS X is calling**.



Using the phone

- To answer the intercom call on the destination handset, press **HOME** , **CELL** , **SPEAKER** , or any dialing key (**0-9**, **✕TONE/a▶A** or **#QUIET**). Both handsets now show **Intercom**.
- To end the intercom call on either handset, one party presses **OFF** or places the handset back in the telephone base or handset charger.

Notes



- You can cancel the intercom call before it is answered by pressing **CANCEL**  or **INT** on the originating handset.
- If the destination handset does not answer the intercom call within 100 seconds, is on a call or out of range, the originating handset displays **Unable to call** and returns to idle mode.

- Press **CANCEL**  or **MUTE** on the destination handset to temporarily silence the intercom ringer.
- Only one intercom call can be established at a time.

Answering an incoming call during an intercom call

When you receive an incoming home call during an intercom call, you will hear an alert tone. Handsets flash  and display the caller ID.

When you receive an incoming cell call during an intercom call, you will hear an alert tone. Handsets flash  and display the caller ID.

- To answer a home call, press **HOME** . The intercom call ends automatically.
- To answer the cell call, press **OFF**. The telephone continues to ring. Then press **CELL** .

- To end the intercom call without answering the outside call, press **OFF**. The intercom call ends and the telephone continues to ring.



Call transfer using intercom

While on an outside call, you can use the intercom feature to transfer the call from one device to another.

- Press **INT** during a call.
-OR-
Press **MENU** during a call. Press **CID/▼** or **▲/📖** to scroll to **Intercom**, then press **SELECT**.
- The screen displays **Intercom to:**
- Use the dialing keys to enter a handset number (**1-5**).
- The handset shows **Calling HS X**. The destination handset rings and shows **HS X is calling**.



Using the phone

3. To answer the intercom call on the destination handset, press **HOME** , **CELL** , **SPEAKER** , or any dialing key (**0-9**, **✕TONE/a▶A** or **#QUIET**). Both handsets now show **Intercom**.
4. To transfer the call, press **OFF** on the initiating handset or place the initiating handset back in the telephone base or charger.
5. To end the intercom call on either handset, one party presses **OFF** or places the handset back in the telephone base or handset charger.

Notes

- You can cancel the intercom call before it is answered by pressing **CANCEL**  or **INT** on the originating handset.

- If the destination handset does not answer within 100 seconds, is in use, on a call, or is out of range, the originating handset displays **Unable to call**, and then reconnects to the outside call.
- You can press **OFF** or **MUTE** on the destination handset to temporarily silence the intercom ringer.
- Only one intercom call can be established at a time.



Redial list

Each handset stores the last 10 telephone numbers dialed (up to 30 digits). When there are already 10 entries, the oldest entry is deleted to make room for the new entry.

Review a redial list entry

1. Press **REDIAL** to enter the redial list.
2. Press **CID/▼**, **▲/📖** or **REDIAL** repeatedly to browse until the desired entry displays.



Dial a redial list entry

1. Press **REDIAL** to enter the redial list.
2. Press **CID/▼**, **▲/📖** or **REDIAL** repeatedly to browse until the desired entry displays.
3. Press **HOME**  or **SPEAKER**  to dial using the home line; or press **CELL**  to dial using the cell line.

-OR-



Using the phone

1. Press **HOME**  or **SPEAKER**  to use the home line; or press **CELL**  to use the cell line.
2. Press **REDIAL** to enter the redial list.
3. Press **CID/▼**, **▲/📖** or **REDIAL** repeatedly to browse until the desired entry displays.
4. Press **SELECT** to dial the displayed number.

Delete a redial list entry

1. Press **REDIAL** to enter the redial list.
2. Press **CID/▼**, **▲/📖** or **REDIAL** repeatedly to browse until the desired entry displays.
3. When the handset displays the number you want to delete, press **DELETE**.

Directory

The directory can store up to 1000 entries, which are shared by all handsets. Each entry may consist of a telephone number up to 30 digits, and a name up to 15 characters.

Any additions, deletions, or edits made on one handset will be reflected on other handsets.

If the telephone number in the directory exceeds 15 digits, a dash appears after the 14th digit and then the remaining digits are shown beginning with a dash alternately.

Add a directory entry

1. Enter the number when the handset is not in use, press **SELECT**, then go to Step 5.
-OR-
Press **MENU** when the handset is not in use.
2. Press **SELECT** to select **Directory**.
3. Press **SELECT** again to select **Add new entry**.
4. When **Enter number** displays, use the dialing keys to enter a number (up to 30 digits).
-OR-
Copy a number from the redial list by pressing **REDIAL**. Then press **CID/▼**, **▲/📖** or **REDIAL** repeatedly to find the desired number. Press **SELECT** to copy the number.



Using the phone

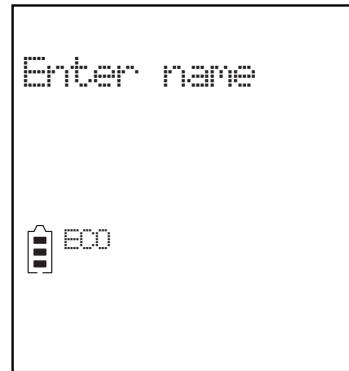
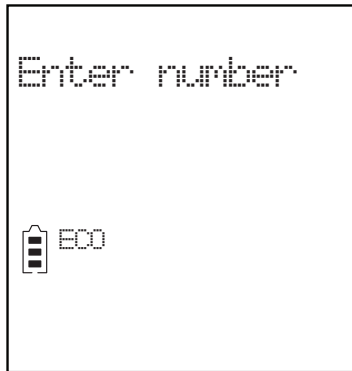

5. Press **SELECT** to move on to the name.
6. When **Enter name** displays, use the dialing keys to enter a name (up to 15 characters). Each time you press a key, the character on that key appears. Additional key presses produce other characters on that key. Press the key repeatedly until the desired character appears. The first character of every word is capitalized.

7. Press **SELECT** to save. You hear a confirmation tone and then the handset returns to the previous menu.

While entering names and numbers, you can:

- Press **CID/▼** or **▲/☞** to move the cursor to the right or left.
- Press **DELETE** to erase a digit.
- Press and hold **DELETE** to erase all digits.

- Press and hold **PAUSE** to enter a dialing pause (a **p** appears).
- Press **0** to add a space.
- Press **✕TONE/a▶A** to change the next letter to upper or lower case.

Review directory entries

Entries are sorted alphabetically.

1. Press **☞** when the handset is not in use. The screen displays the first entry in the directory.
2. Press **CID/▼** or **▲/☞** to browse through the directory, or use the dialing keys to start a name search.

-OR-

1. Press **MENU** when the handset is not in use.



Using the phone

2. Press **SELECT** to select **Directory**.
3. Press **CID/▼** or **▲/☞** to choose **Review**, and then press **SELECT**.

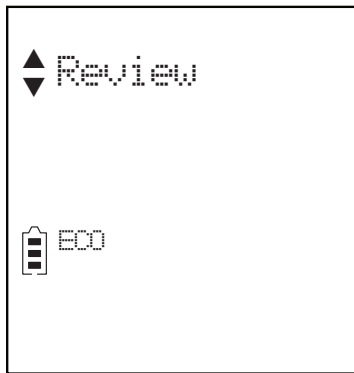

4. The screen displays the first entry in the directory. Press **CID/▼** or **▲/☞** to browse through the directory.

Note

- If the telephone number in the directory exceeds 15 digits, - appears in front of the telephone number and shows the remaining numbers alternately.

Alphabetical search

1. Follow the steps in **Review directory entries** to enter the directory.
2. Use the dialing keys to enter the letter associated with the name. For example, if you have entries for Jenny, Jessie, Kristen and Laura in your directory, press **5** (JKL) once to see Jenny (when **Jenny** displays, press **CID/▼** to see **Jessie**), twice to see Kristen, or three times to see Laura. If there is no name entry matching your search, the next closest match in alphabetical order appears. If necessary, press **CID/▼** or **▲/☞** to browse.



Edit a directory entry

1. Search for the desired entry in the directory (see **Review directory entries** or **Alphabetical search**).
2. When the desired entry displays, press **SELECT**. The handset displays **Enter number**.
3. Use the dialing keys to edit the number, and then press **SELECT**. The handset displays **Enter name**.
4. Use the dialing keys to edit the name.
5. Press **SELECT** to save the entry. You hear a confirmation tone. The handset displays the revised entry.



Using the phone

Dial a directory entry

1. Search for the desired entry in the directory (see **Review directory entries** or **Alphabetical search**).
2. Press **HOME**  or **SPEAKER**  to dial using the home line; or press **CELL**  to dial using the cell line.

Delete a directory entry

1. Search for the desired entry in the directory (see **Review directory entries** or **Alphabetical search**).
2. When the desired entry displays, press **DELETE**. The screen displays **Delete entry?**.



3. Press **SELECT** to confirm. The screen displays **Deleting...** You hear a confirmation tone and then the handset returns to previous menu.

Delete all directory entries

1. Press **MENU** when the handset is not in use.
2. Press **CID/▼** or **▲/☰** to choose **Directory**, and then press **SELECT**.
3. Press **CID/▼** or **▲/☰** to choose **Delete all**, and then press **SELECT**.
 - The handset displays **Delete all?**. Press **SELECT** to confirm. The screen displays **Deleting...** You hear a confirmation tone and then the handset returns to previous menu.



Using the phone

Caller ID

If you subscribe to caller ID service, information about each caller appears after the first or second ring. If you answer a call before the caller information appears on the screen, it will not be saved in the caller ID log.

The caller ID log stores up to 50 entries. Each entry has up to 24 digits for the phone number and 15 characters for the name.

If the telephone number has more than 15 digits, only the last 15 digits appear.

If the name has more than 15 characters, only the first 15 characters are shown and saved in the caller ID log.

Entries appear in reverse chronological order. When the caller ID log is full, the oldest entry is deleted to make room for new incoming call information.

Caller ID log entries are shared by all system handsets (for multiple handset models only). Any deletions made on one handset are reflected on all other handsets.

Note

- *This product can provide information only if both you and the caller are in areas offering caller ID service and if both telephone service providers use compatible equipment. The time and date are sent by your telephone service provider along with the call information.*

Review the caller ID log

1. Press **CID** when the handset is not in use. The screen displays the first entry in the caller ID log.
2. Press **CID/▼** or **▲/☰** to browse.

-OR-

1. Press **MENU** when the handset is not in use.
2. Press **CID/▼** or **▲/☰** to scroll to Caller ID log, and then press **SELECT** twice to choose **Review**. The handset displays the first entry.
3. Press **CID/▼** or **▲/☰** to browse.

Note

- *You hear a double beep when you reach the beginning or end of the caller ID log.*



Using the phone

Memory match

When the incoming telephone number matches the last seven digits of a telephone number in your directory, the screen displays the stored name of the directory entry.

For example, if Mike Smith calls, his name appears as **Mike** if this is how you entered it into your directory.

Note

- *The number shown in the caller ID log will be in the format sent by the telephone service provider. The telephone service provider usually delivers 10-digit phone numbers (area code plus telephone number). If the phone number of the caller does not match a number in your*

directory, the name will appear as it is delivered by the telephone service provider.

Missed call indicator

When there are calls that have not been reviewed in the caller ID log, the handsets display **XX missed calls**.



Each time you review a caller ID log entry marked **NEW**, the number of missed calls decreases by one.



When you have reviewed all the missed calls, the missed call indicator disappears.

If you do not want to review the missed calls one by one, press and hold **CANCEL** on the handset when not in use to clear the missed call indicator. All the entries are then considered old.



Using the phone



View dialing options

Although the caller ID log entries received have 10 digits (the area code plus the seven-digit number), in some areas, you may need to dial only the seven digits, or **1** plus the seven digits, or **1** plus the area code plus the seven digits. You can change the number of digits that you dial from the caller ID log and store the new number to the directory.

While reviewing the caller ID log, press **#** (pound key) repeatedly to display different dialing options for local and long distance numbers before dialing or saving the telephone number in the directory.

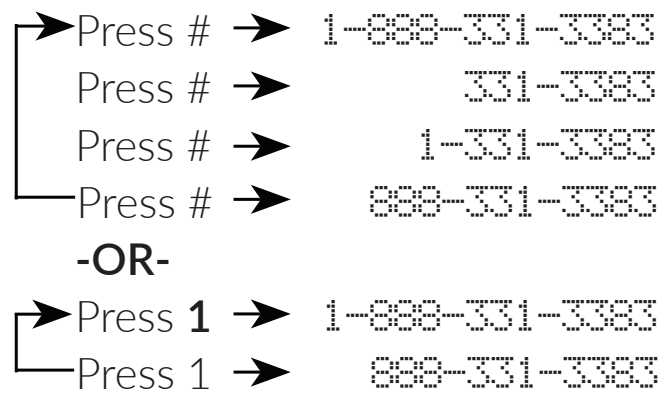
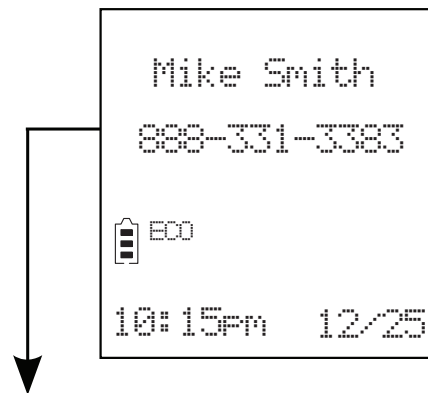
Press **1** repeatedly if you need to add **1** in front of the telephone number before dialing or saving it in the directory.





When the number is displayed in the correct format for dialing, press **HOME** , **CELL**  or **SPEAKER**  to dial.

Note

*If you have programmed the home area code, only the last seven digits of the incoming phone numbers from that area code will be displayed while reviewing the caller ID log. Press **#** repeatedly to display all possible dialing options.*

Dial a caller ID log entry

1. Search for the desired caller ID log entry (see **Review the Caller ID log**).
2. When the desired entry displays, press **HOME** , **CELL**  or **SPEAKER**  to dial.



Using the phone

Save a caller ID log entry to the directory

1. Search for the desired caller ID log entry (see **Review the Caller ID log**).
2. When the desired entry displays, press **SELECT**.
3. Press **SELECT** again to choose **Directory**. Then the handset displays **Enter number**.
4. Use the dialing keys to edit the number, when necessary. Press **SELECT** to move to the name. The handset displays **Enter name**.
5. Use the dialing keys to add or edit the name.
6. Press **SELECT** when done and you hear a confirmation tone.

While entering names and numbers, you can:

- Press **CID/▼** or **▲/☞** to move the cursor to the right or left.
- Press **DELETE** to erase a digit.
- Press and hold **DELETE** to erase all digits.
- Press and hold **PAUSE** to enter a dialing pause (a **p** appears).
- Press **0** to add a space while editing a name or number.
- Press **✕TONE/a▶A** to change the next letter to upper or lower case.

Note

- If you save an entry which already exists in the directory, the handset displays **Number repeated** and then returns to the previous screen.

Delete a caller ID log entry

1. Search for the desired caller ID log entry (see **Review the Caller ID log**).
2. Press **DELETE** to delete the displayed entry.

Delete all caller ID log entries

1. Press **MENU** when the handset is not in use.
2. Press **CID/▼** or **▲/☞** to scroll to **Caller ID log**, and then press **SELECT**.
3. Press **CID/▼** or **▲/☞** to scroll to **Delete all**, and then press **SELECT**.





Using the phone

- When the screen shows **Delete all?** Press **SELECT** to confirm. The screen displays **Deleting...** and then you hear a confirmation tone.



Call block

If you have subscribed to caller ID service, you can set the telephone to block unknown calls and certain undesired calls. The call block list stores up to 20 entries.

When a home line is blocked, the caller will hear a simulated busy tone for one ring cycle. You may pick up the call during the first ring when there is no caller ID information. Otherwise, the call is disconnected.

Block unknown calls

All incoming calls with unknown numbers will be blocked.

- Press **CALL BLOCK** when the handset is not in use.
-OR-
Press **MENU** when the handset is not in use. Press **CID/▼** or **▲/☞** to choose **Call Block**, and then press **SELECT**.
- Press **CID/▼** or **▲/☞** to choose **Calls w/o num**, and then press **SELECT**.

- Press **CID/▼** or **▲/☞** to choose **Unblock** or **Block**, then press **SELECT**. You hear a confirmation tone.

Add a call block list entry

- Press **CALL BLOCK** when the handset is not in use.
-OR-
Press **MENU** when the handset is not in use. Press **CID/▼** or **▲/☞** to choose **Call Block**, and then press **SELECT**.
- Press **CID/▼** or **▲/☞** to choose **Block list**, and then press **SELECT**.
- Press **CID/▼** or **▲/☞** to choose **Add new entry**, and then press **SELECT**.



Using the phone

4. When **Enter number** displays, use the dialing keys to enter a number (up to 30 digits).

-OR-

Copy a number from the redial list by pressing **REDIAL**. Then press **CID/▼**, **▲/☞** or **REDIAL** repeatedly to find the desired number. Press **SELECT** to copy the number.

5. Press **SELECT** to move on to the name.

6. When **Enter name** displays, use the dialing keys to enter a name (up to 15 characters). Additional key presses produce other characters on that key. The first character of every word is capitalized.

7. Press **SELECT** to save. You hear a confirmation tone and then the screen returns to the previous menu.

While entering names and numbers, you can:

- Press **CID/▼** or **▲/☞** to move the cursor to the left or right.
- Press **DELETE** to erase a digit.
- Press and hold **DELETE** to erase all digits.
- Press and hold **PAUSE** to enter a dialing pause (a p appears).
- Press **0** to add a space (for entering names only).
- Press **✕TONE/a▶A** to change the next letter to upper or lower case.

Review the call block list

1. Press **CALL BLOCK** when the handset is not in use.

-OR-

Press **MENU** when the handset is not in use. Press **CID/▼** or **▲/☞** to choose **Call Block**, and then press **SELECT**.

2. Press **CID/▼** or **▲/☞** to choose **Block list**, and then press **SELECT**.

3. Press **SELECT** to choose **Review**.

4. When an entry displays, press **CID/▼** or **▲/☞** to browse. You hear a double beep when you reach the beginning or end of the caller block list.



Using the phone

Note

- When you access the call block list without records, the screen shows **List empty**.

Edit a call block list entry

1. Search for the desired block list entry (see **Review the call block list**).
2. When the desired entry displays, press **SELECT**. The handset displays **Enter number**.
3. Use the dialing keys to edit the number.
4. Press **SELECT** to move to the name. The handset displays **Enter name**.
5. Use the dialing keys to add or edit the name.

6. Press **SELECT** to save the entry. You hear a confirmation tone.

Save a caller ID log entry to the call block list

1. Search for the desired caller ID log entry (see **Review the caller ID log**).
2. When the desired entry displays, press **SELECT**.
3. Press **CID/▼** or **▲/☞** to choose **To Call block**, and then press **SELECT**. Then the handset displays **Enter number**.
4. Use the dialing keys to edit the number, when necessary.
5. Press **SELECT** to move to the name. The handset displays **Enter name**.
6. Use the dialing keys to add or edit the name.

7. Press **SELECT** when done.

Note

- If you save an entry which already exists in the call block list, the handset displays **Number repeated** and then returns to previous screen.

Delete a call block list entry

1. Search for the desired block list entry (see **Review the call block list**).
2. Press **DELETE**. You hear a confirmation tone and the handset displays the next entry.

Note

- If the call block list is empty after an entry is deleted, the handset displays **List empty**. You hear a confirmation tone.



Using the phone

Mute first ring

Your telephone rings once for blocked calls. You can choose to mute the first ring for all incoming calls, so that there will be no ring for blocked calls. By default, the first ring is set to **On**.

1. Press **MENU** when the handset is not in use.
2. Press **7464#** on the handset.
3. Scroll to choose **First ring:On** to keep the first ring, or **First ring:Off** to mute the first ring.
4. Press **SELECT** to save.

Note

- *When you have muted the first ring, you will hear one ring less before the answering system and voicemail answer the incoming calls.*

Sound settings

Key tone

You can turn the key tone on or off for each handset. If you turn the key tone off, there are no beeps when you press the handset keys.

1. Press **MENU** when the handset is not in use.
2. Press **CID/▼** or **▲/☞** to choose **Settings**, and then press **SELECT**.
3. Press **CID/▼** or **▲/☞** to choose **Key tone**, and then press **SELECT**.
4. Press **CID/▼** or **▲/☞** to choose **On** or **Off**.
5. Press **SELECT** to save your selection. Then the handset returns to the previous menu. You hear a confirmation tone.

Ringer tone

You can choose from different ringer tones for each handset.

1. Press **MENU** when the handset is not in use.
2. Press **CID/▼** or **▲/☞** to choose **Ringers**, and then press **SELECT**.
3. Press **CID/▼** or **▲/☞** to choose **Home ringtone** or **Cell ringtone**, and then press **SELECT**.
4. Press **CID/▼** or **▲/☞** to sample each ringer tone.
5. Press **SELECT** to save your selection. Then the handset returns to the previous menu. You hear a confirmation tone.



Using the phone

Note

- If you turn off the ringer volume, you will not hear ringer tone samples.

Handset ringer volume

You can set the ringer volume or turn the ringer off on each handset. When the ringer is off,  appears on the screen.

1. Press **MENU** when the handset is not in use.
2. Press **CID/▼** or **▲/📖** to choose **Ringers**, and then press **SELECT**.
3. Press **SELECT** to choose **Home volume** or **Cell volume**, and then press **SELECT**.
4. Press **CID/▼** or **▲/📖** to sample each volume level.

5. Press **SELECT** to save your selection. Then the handset returns to the previous menu. You hear a confirmation tone.

Note

- The ringer volume also determines the ringer volume for intercom calls. If the ringer volume is set to off, that handset is silenced for all incoming calls except paging tone.

Temporary ringer silencing

When the telephone is ringing, you can temporarily silence the ringer of the handset without disconnecting the call. The next call rings normally at the preset volume.

Silence the handset ringer

Press **CANCEL** or **MUTE** on the handset and it displays **Ringer muted** and .

Note

- Each handset and the base ring when there is an incoming call unless the ringer volume of that device is turned off.

Quiet mode

You can turn on the quiet mode for a period of time (1-12 hours). During this period, all tones (except paging tone) are muted.

1. Press and hold **#QUIET** when the handset is not in use.
2. The handset displays **Quiet: __ hours**. Use the dialing keys (**0-9**) to enter the desired duration (1-12).
3. Press **SELECT** to save. You hear a confirmation tone. The handset displays **Quiet mode on** and .



Using the phone

Turn off the quiet mode

Press and hold **#QUIET** when the handset is not in use. The handset displays **Quiet mode off** briefly and then returns to idle.

Note

- *When you change the settings of the ringer tone or ringer volume, you can still hear the samples even if the quiet mode is on.*

Other settings

Home area code

When you dial your local calls using only seven digits (area code not required), you can program your home area code so that when you receive a call within your local area, the telephone number is automatically stored without the area code in the caller ID log.

1. Press **MENU** when the handset is not in use.
2. Press **CID/▼** or **▲/☞** to choose **Settings**, and then press **SELECT**.
3. Press **CID/▼** or **▲/☞** to choose **Home area code**, and then press **SELECT**.
4. Use the dialing keys to enter a three-digit home area code.
5. Press **SELECT** to save your selection. Then the handset returns to the previous menu. You hear a confirmation tone.

Note

- *If, in the future, your telephone service provider requires you to dial the area code when making a local call, or, if you move to a location that requires it, delete the home area code you have*

already programmed, following the steps above. After you have deleted the home area code, _ _ _ will appear on the display.

Dial mode

The dial mode is preset to touch-tone dialing. If you have pulse (rotary) service, you must change the dial mode to pulse dialing before using the telephone to make a call.

1. Press **MENU** when the handset is not in use.
2. Press **CID/▼** or **▲/☞** to choose **Settings**, and then press **SELECT**.
3. Press **CID/▼** or **▲/☞** to choose **Dial mode**, and then press **SELECT**.
4. Press **CID/▼** or **▲/☞** to choose **Touch-tone** or **Pulse**.



Using the phone

5. Press **SELECT** to save your selection. Then the handset returns to the previous menu. You hear a confirmation tone.

Temporary tone dialing

If you have pulse (rotary) service only, you can switch from pulse to touch-tone dialing temporarily during a call. This is useful if you need to send touch-tone signals to access your telephone banking or long distance services.

1. During a call, press **✕TONE/a▶A**.
2. Use the dialing keys to enter the number you wish to dial.
3. The telephone sends touch-tone signals. The telephone automatically returns to pulse dialing mode after you end the call.

Retrieve voicemail from telephone service

Voicemail is a feature available from most telephone service providers. It may be included with your telephone service, or may be optional. Fees may apply.

Retrieve voicemail

When you received a voicemail, the handset displays **New voicemail** and .



To retrieve, you typically dial an access number provided by your telephone service provider, and then enter a security code. Contact your telephone service provider for instructions on how to configure the voicemail settings and listen to messages.

Note

- *After you have listened to all new voicemail messages, the indicators on the handset turn off automatically.*

Set your voicemail number

You can save your access number on each handset for easy access to your voicemail number, you can press and hold **1**  to retrieve voicemail.



Using the phone

1. Press **MENU** when the handset is not in use.
2. Press **CID/▼** or **▲/☞** to choose **Settings**, and then press **SELECT**.
3. Press **CID/▼** or **▲/☞** to choose **Settings**, and then press **SELECT**.
4. Use the dialing keys to enter the voicemail number (up to 30 digits).
5. Press **SELECT** to save.

Turn off the new voicemail indicators

When you have retrieved your voicemail while away from home, and the handset still displays the new voicemail indicators, use this feature to turn off the indicators.

Note

- *This feature turns off the indicators only, it does not delete your voicemail messages.*

1. Press **MENU** when the handset is not in use.
2. Press **CID/▼** or **▲/☞** to choose **Settings**, and then press **SELECT**.
3. Press **CID/▼** or **▲/☞** to choose **Clr voicemail**, and then press **SELECT**. You hear a confirmation tone.

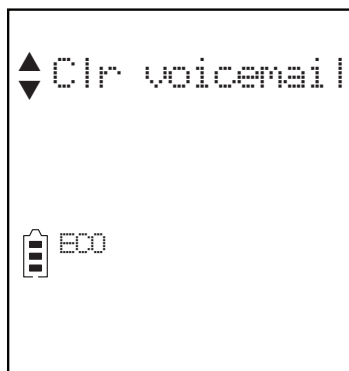

Cell phone voicemail

If you have voicemail service active on your cell phone, and you do not answer the incoming cell call, the call will be answered by your cell phone's voicemail. Contact your cell phone service provider for more information about voicemail service.

Expand your telephone system

You can add new handset (**XT8**) to your telephone system. All accessories are sold separately. Your telephone base supports a maximum of five devices.

For more details, refer to the user's manual that comes with your new device.



Help

Help

Phone does not work

Low battery

Fail to dial out

No dial tone

Not registered

Fail to connect cell phone
or headset to the
telephone base

Poor cell phone reception

Fail to charge handset
battery

Phone does not ring when
there is an incoming call

Handset beeps and not
functioning normally

Hear other calls when
using the phone

Noise interruption

Interference during phone
conversation

Fail to show Caller ID

Out of range

Computer-established
connections problems

Changing LCD language

**My telephone does not work
at all.**

Make sure the telephone base is installed properly, and battery is installed and charged correctly. For optimum daily performance, return the handset to the telephone base after use.

The display shows Low battery.

Place the handset in the telephone base or charger for charging.



I cannot dial out.

- Make sure there is a dial tone before dialing. It is normal if the handset takes a second or two to synchronize with the telephone base before producing a dial tone. Wait an extra second before dialing.
- Eliminate any background noise. Mute the handset before dialing, or dial from another room in your home with less background noise.

The display shows **No line.** I cannot hear the dial tone.

- Disconnect the telephone line cord from your telephone and connect it to another telephone. If there is no dial tone on that other telephone either, then the telephone line cord may be defective. Try installing a new telephone line cord. If changing telephone line cord does not help, the wall jack (or the wiring to this wall jack) may be defective. Contact your telephone service provider.
- You may be using a new cable or VoIP service, the existing telephone jacks in your home may no longer work. Contact your service provider for solutions.

The display shows **To register HS...** and **...see manual alternately.** The handset does not work at all.

The handset is deregistered from the telephone base.

Place the handset in the telephone base to register it back.

After about 10 seconds, the handset displays **Registering...** When the registration process completes, the handset displays **Registered** and you hear a beep. The registration process takes about 90 seconds.



I cannot add and connect my cell phone or headset to the telephone base

- Make sure you have cellular coverage and the Bluetooth function of your cell phone or headset is turned on. See the user's manual of your cell phone or headset for more information.
- Make sure that the telephone base is in discoverable mode.
- Carefully follow the instructions in this manual.
- Make sure that your Bluetooth cell phone headset is not connected to any other Bluetooth device, and is connected to the telephone base and active on the device list.

- Turn off your cell phone or headset, and then turn it on again.

The cell phone reception in my house is poor and I cannot connect it to my RT802/RT803/RT804/RT803XT/RT804T/RT805XT.

If there is a location in your house with better reception, you can leave your cell phone at that location while you use the **RT802/RT803/RT804/RT803XT/RT804T/RT805XT** cell line. In order for this to work, the telephone base must be within 15 feet of the cell phone.

The battery does not charge in the handset or the handset battery does not accept charge.

- Make sure the handset is placed in the telephone base or charger correctly.
- If the battery is completely depleted, charge the battery for at least 30 minutes before use.
- You may need to purchase a new battery.

The telephone does not ring when there is an incoming call.

- Make sure the ringer volume is not set to off.
- The handset may be too far from the telephone base. Move it closer to the telephone base.



My handset beeps and is not performing normally.

Move the handset closer to the telephone base. It may be out of range.

I hear other calls when using the telephone.

Disconnect the telephone base from the telephone wall jack. Plug in a different telephone. If you still hear other calls, the problem is probably in the wiring or telephone service. Contact your telephone service provider.

I hear noise on the cordless handset and the keys do not work.

Make sure the telephone line cord is plugged in securely.

There is interference during a telephone conversation. My calls fade out when I am using the cordless handset.

- The handset may be out of range. Move it closer to the telephone base.
 - If you subscribe to high-speed Internet service (DSL - digital subscriber line) through your telephone line, you must install a DSL filter between the telephone line cord and the telephone wall jack. The filter prevents noise and caller ID problems caused by DSL interference. Contact your DSL service provider for more information about DSL filters.
- Appliances or other cordless telephones plugged into the same circuit as the telephone base can cause interference. Try moving the appliance or telephone base to another outlet.
 - The location of your telephone base can impact the performance of your cordless phone. For better reception, install the telephone base in a centralized location within your home or office, away from walls or other obstructions. In many environments, elevating the telephone base improves overall performance.



The telephone does not receive caller ID or the telephone does not show caller ID during call waiting.

- Caller ID is a subscription service. You must subscribe to this service from your telephone service provider for this feature to work on your telephone.
- Both your and the caller's telephone service providers must use equipment compatible with the caller ID service.
- The caller may not be calling from an area which supports caller ID.
- The caller ID information displays after the first or second ring.

The display shows Out of range or no pwr at base.

- The handset may be out of range. Move it closer to the telephone base.
- Make sure the power cord is securely plugged into the telephone base. Use a working electrical outlet not controlled by a wall switch.

I subscribe to a nontraditional telephone service that uses my computer to establish connections, and my telephone doesn't work.

- Make sure your computer is powered on, and your Internet is working properly.
- Make sure to plug your USB telephone adapter into a dedicated USB port on your computer. Do not plug into a multiple port USB hub (USB splitter) that is not powered.
- In a few rare instances, the USB port on your computer may not have enough power. In these instances, try using a USB hub with its own external power supply.



Help

- If you are using a firewall, it may prevent access to your nontraditional telephone service. Contact your service provider for more information.

I accidentally set my LCD language to Spanish or French, and I don't know how to change it back to English.

While the handset is not in use or is on a call, press **MENU** and then enter ***364#** to change the handset LCD language back to English.



General Information

General Information

Product care

Important safety instructions

Unplug the phone if...

Installation Guidelines

Battery safety instructions

Warranty

Exclusions

FCC, ACTA and IC regulations

Technical Specifications

If your product is not working properly...

1. Read the User's Guide.
2. Visit our website:
www.motorolastore.com
3. Contact Customer Service:
US and Canada: 1-888-331-3383
Email:
support@motorolahome.com
Please download full user manual from our website. Website:
www.motorolastore.com

To order a replacement battery pack contact customer service or visit our website.

Important safety instructions

Follow these safety precautions when using your phone to reduce the risk of fire, electric shock, and injury to persons or property:

1. Keep all vents and openings of the phone unblocked. Do not set the phone on a heating register or over a radiator. Ensure that proper ventilation is provided at the installation site.
2. Do not use while wet or while standing in water.
3. Do not use this product near water (for example, near a bath tub, kitchen sink, or swimming pool).



General Information

4. Do not allow anything to rest on the power cord. Place the power cord so that it will not be walked on.
5. Never insert objects of any kind into the product vents as that may result in fire or electric shock.
6. Unplug this product from the electrical outlet before cleaning. Do not use liquid cleaners or aerosol cleaners. Use a damp cloth for cleaning.
7. Do not disassemble this product. If service or repair work is required, contact the customer service helpline found in this User's Guide.
8. Do not overload wall outlets and extension cords.
9. Avoid using during an electrical storm. Use a surge protector to protect the equipment.
10. Do not use this phone to report a gas leak, especially if you are in the vicinity of the gas line.

CAUTION

To reduce the risk of fire, use only No. 26 AWG or larger UL Listed or CSA Certified Telecommunication Line Cord.

Unplug this cordless phone immediately from an outlet if:

- The power cord or plug is damaged or frayed.
- Liquid has been spilled on the product.
- The product has been exposed to rain or water. Do not retrieve the handset or base until after you have unplugged the power and phone from the wall. Then retrieve the unit by the unplugged cords.
- The product has been dropped or the cabinet has been damaged.
- The product exhibits a distinct change in performance.



General Information

Installation Guidelines

1. Read all instructions and save them for future reference.
2. Follow all warnings and instructions marked on the product.
3. Do not install this product near a bath tub, sink, or shower.
4. Operate this phone using only the power source that is indicated on the marking label. If you are unsure of the power supply to your home, consult with your dealer or local power company.
5. Do not place this product on an unstable cart, stand, or table. This product may fall, causing serious damage to the product.
6. Adjust only those controls that are covered by the operating instructions. Improper adjustment of other controls may result in damage and will often require extensive work to restore the product to normal operation.
7. Clean this product with a soft, damp cloth. Do not use chemicals or cleaning agents to clean this phone.
8. Use only the power supply that came with this unit. Using other power supplies may damage the unit.
9. Because this phone operates on electricity, you should have at least one phone in your home that operates without electricity in case of a power outage.
10. To avoid interference to nearby appliances, do not place the base of the phone on or near a TV, microwave oven, or VCR.

CAUTION

To maintain compliance with the FCC's RF exposure guidelines, place the base unit at least 20 cm from nearby persons.



General Information

Battery Safety Instructions

Do not burn, disassemble, mutilate, or puncture the battery. The battery contains toxic materials that could be released, resulting in injury.

CAUTION

There is a risk of explosion if you replace the battery with an incorrect battery type. Use only the battery pack that came with your phone or an authorized replacement recommended by the manufacturer.

- *Keep battery packs out of the reach of children.*
- *Remove battery packs if storing over 30 days.*

- *Do not dispose of battery packs in fire, which could result in explosion.*
- *The rechargeable battery packs that power this product must be disposed of properly and may need to be recycled. Refer to the battery label for battery type. Contact your local recycling center for proper disposal methods.*

SAVE THESE INSTRUCTIONS

Warranty

Thank you for purchasing this Motorola branded product manufactured under license by Binatone Electronics International LTD ("BINATONE").

What Does this Warranty Cover?

Subject to the exclusions contained below, BINATONE warrants that this Motorola branded product ("Product") or certified accessory ("Accessory") sold for use with this product that it manufactured to be free from defects in materials and workmanship under normal consumer usage for the period outlined below. This Warranty is your exclusive warranty and is not transferable.



General Information

Who is covered?

This Warranty extends only to the first consumer purchaser, and is not transferable.

What will BINATONE do?

BINATONE or its authorized distributor at its option and within a commercially reasonable time, will at no charge repair or replace any Products or Accessories that does not conform to this Warranty. We may use functionally equivalent reconditioned/ refurbished/ preowned or new Products, Accessories or parts.

What Other Limitations Are There?

ANY IMPLIED WARRANTIES, INCLUDING WITHOUT LIMITATION THE IMPLIED WARRANTIES OF MERCHANTABILITY AND FITNESS FOR A PARTICULAR PURPOSE, SHALL BE LIMITED TO THE DURATION OF THIS LIMITED WARRANTY, OTHERWISE THE REPAIR OR REPLACEMENT PROVIDED UNDER THIS EXPRESS LIMITED WARRANTY IS THE EXCLUSIVE REMEDY OF THE CONSUMER, AND IS PROVIDED IN LIEU OF ALL OTHER WARRANTIES, EXPRESS OF IMPLIED. IN NO EVENT SHALL MOTOROLA OR BINATONE BE LIABLE,

WHETHER IN CONTRACT OR TORT (INCLUDING NEGLIGENCE) FOR DAMAGES IN EXCESS OF THE PURCHASE PRICE OF THE PRODUCT OR ACCESSORY, OR FOR ANY INDIRECT, INCIDENTAL, SPECIAL OR CONSEQUENTIAL DAMAGES OF ANY KIND, OR LOSS OF REVENUE OR PROFITS, LOSS OF BUSINESS, LOSS OF INFORMATION OR OTHER FINANCIAL LOSS ARISING OUT OF OR IN CONNECTION WITH THE ABILITY OR INABILITY TO USE THE PRODUCTS OR ACCESSORIES TO THE FULL EXTENT THESE DAMAGES MAY BE DISCLAIMED BY LAW.



General Information

Some jurisdictions do not allow the limitation or exclusion of incidental or consequential damages, or limitation on the length of an implied warranty, so the above limitations or exclusions may not apply to you. This Warranty gives you specific legal rights, and you may also have other rights that vary from one jurisdiction to another.

Products covered	Length of coverage
CONSUMER PRODUCTS	One (1) year from the date of the products original purchase by the first consumer purchaser of the product.
Consumer Accessories	Ninety (90) days from the date of the accessories original purchase by the first consumer purchaser of the product.
Consumer Products and Accessories that are Repaired or Replaced	The balance of the original warranty or for ninety (90) days from the date returned to the consumer, whichever is longer.

Exclusions

Normal Wear and Tear.

Periodic maintenance, repair and replacement of parts due to normal wear and tear are excluded from coverage.

Batteries. Only batteries whose fully charged capacity falls below 80% of their rated capacity and batteries that leak are covered by this Warranty.



General Information

Abuse & Misuse. Defects or damage that result from: (a) improper operation, storage, misuse or abuse, accident or neglect, such as physical damage (cracks, scratches, etc.) to the surface of the product resulting from misuse; (b) contact with liquid, water, rain, extreme humidity or heavy perspiration, sand, dirt or the like, extreme heat, or food; (c) use of the Products or Accessories for commercial purposes or subjecting the Product or Accessory to abnormal usage or conditions; or (d) other acts which are not the fault of MOTOROLA or BINATONE., are excluded from coverage.

Use of Non-Motorola branded Products and Accessories. Defects or damage that result from the use of Non-Motorola branded or certified Products or Accessories or other peripheral equipment are excluded from coverage. Unauthorized Service or Modification. Defects or damages resulting from service, testing, adjustment, installation, maintenance, alteration, or modification in any way by someone other than MOTOROLA, BINATONE or its authorized service centers, are excluded from coverage.

Altered Products. Products or Accessories with (a) serial numbers or date tags that have been removed, altered or obliterated; (b) broken seals or that show evidence of tampering; (c) mismatched board serial numbers; or (d) nonconforming or non-Motorola branded housings, or parts, are excluded from coverage.

Communication Services. Defects, damages, or the failure of Products or Accessories due to any communication service or signal you may subscribe to or use with the Products or Accessories is excluded from coverage.



General Information

How to Obtain Warranty Service or Other Information?

You will receive instructions on how to ship the Products or Accessories at your expense and risk, to a BINATONE Authorized Repair Center.

To obtain service, you must include: (a) the Product or Accessory; (b) the original proof of purchase (receipt) which includes the date, place and seller of the Product; (c) if a warranty card was included in your box, a completed warranty card showing the serial number of the Product; (d) a written description of the problem; and, most importantly; (e) your address and telephone number.

These terms and conditions constitute the complete warranty agreement between you and BINATONE, regarding the Products or Accessories purchased by you, and supersede any prior agreement or representations, including representations made in any literature publications or promotional materials issued by BINATONE, or representations made by any agent employee or staff of BINATONE, that may have been made in connection with the said purchase.

FCC, ACTA and IC regulations

FCC Part 15

This equipment has been tested and found to comply with the requirements for a Class B digital device under Part 15 of the Federal Communications Commission (FCC) rules. These requirements are intended to provide reasonable protection against harmful interference in a residential installation. This equipment generates, uses and can radiate radio frequency energy and, if not installed and used in accordance with the instructions, may cause harmful interference to radio communications. However, there



General Information

is no guarantee that interference will not occur in a particular installation. If this equipment does cause harmful interference to radio or television reception, which can be determined by turning the equipment off and on, the user is encouraged to try to correct the interference by one or more of the following measures:

- Reorient or relocate the receiving antenna.
- Increase the separation between the equipment and receiver.
- Connect the equipment into an outlet on a circuit different from that to which the receiver is connected.
- Consult the dealer or an experienced radio/TV technician for help.

Changes or modifications to this equipment not expressly approved by the party responsible for compliance could void the user's authority to operate the equipment.

This device complies with Part 15 of the FCC rules. Operation is subject to the following two conditions: (1) this device may not cause harmful interference, and (2) this device must accept any interference received, including interference that may cause undesired operation. Privacy of communications may not be ensured when using this telephone.

To ensure safety of users, the FCC has established criteria for the amount of radio frequency energy that can be safely absorbed by a user or bystander

according to the intended usage of the product. This product has been tested and found to comply with the FCC criteria. The handset may be safely held against the ear of the user. The telephone base shall be installed and used such that parts of the user's body other than the hands are maintained at a distance of approximately 20 cm (8 inches) or more.

For body-worn operation, this handset has been tested and meets the FCC RF exposure guidelines. Use of other accessories may not ensure compliance with FCC RF exposure guidelines.

This Class B digital apparatus complies with Canadian requirement:
CAN ICES-3 (B)/NMB-3(B)



General Information

FCC Part 68 and ACTA

This equipment complies with Part 68 of the FCC rules and with technical requirements adopted by the Administrative Council for Terminal Attachments (ACTA). The label on the back or bottom of this equipment contains, among other things, a product identifier in the format US:AAAEQ##TXXXX. This identifier must be provided to your telephone service provider upon request.

The plug and jack used to connect this equipment to premises wiring and the telephone network must comply with applicable Part 68 rules and technical requirements adopted by ACTA. A compliant

telephone cord and modular plug are provided with this product. It is designed to be connected to a compatible modular jack that is also compliant. An RJ11 jack should normally be used for connecting to a single line and an RJ14 jack for two lines. See the installation instructions in the user's manual.

The Ringer Equivalence Number (REN) is used to determine how many devices you may connect to your telephone line and still have them ring when you are called. The REN for this product is encoded as the 6th and 7th characters following the US: in the product identifier (e.g., if ## is 03, the REN is 0.3). In most, but not all areas, the sum of all RENs

should be five (5.0) or less. For more information, contact your telephone service provider.

This equipment must not be used with Party Lines. If you have specially wired alarm dialing equipment connected to your telephone line, ensure the connection of this equipment does not disable your alarm equipment. If you have questions about what will disable alarm equipment, consult your telephone service provider or a qualified installer.

If this equipment is malfunctioning, it must be unplugged from the modular jack until the problem has been corrected. Repairs to this telephone equipment can only



General Information

be made by the manufacturer or its authorized agents. For repair procedures, follow the instructions outlined under the Limited warranty.

If this equipment is causing harm to the telephone network, the telephone service provider may temporarily discontinue your telephone service. The telephone service provider is required to notify you before interrupting service. If advance notice is not practical, you will be notified as soon as possible. You will be given the opportunity to correct the problem and the telephone service provider is required to inform you of your right to file a complaint with the FCC. Your telephone service

provider may make changes in its facilities, equipment, operation, or procedures that could affect the proper functioning of this product. The telephone service provider is required to notify you if such changes are planned.

If this product is equipped with a corded or cordless handset, it is hearing aid compatible.

If this product has memory dialing locations, you may choose to store emergency telephone numbers (e.g., police, fire, medical) in these locations. If you do store or test emergency numbers, please:

Remain on the line and briefly explain the reason for the call before hanging up.

Perform such activities in off-peak hours, such as early morning or late evening.



General Information

Technical Specifications

Frequency control	Crystal controlled PLL synthesizer
Transmit frequency	Handset: 1921.536- 1928.448 MHz Telephone base: 1921.536- 1928.448 MHz Bluetooth: 2402.000- 2480.000 MHz
Channels	DECT channel: 5 Bluetooth channel: 79
Nominal effective range	Maximum power allowed by FCC and IC. Actual operating range may vary according to environment conditions at the time of use.

Power requirements	Handset: 2.4V Ni-MH battery Telephone base: Input: 110V AC Output: 6V DC/600mA Charger: Input: 110V AC Output: 6V DC/400mA
---------------------------	--

Memory	Handset directory: 1000 memory locations; up to 30 digits and 15 characters Handset caller ID log: 50 memory locations; up to 24 digits and 15 characters Handset call block: 20 entries
---------------	---

Manufactured, distributed or sold by Binatone Electronics International LTD., official licensee for this product.

MOTOROLA and the Stylized M Logo, are trademarks or registered trademarks of Motorola Trademark Holdings, LLC. and are used under license.

The Bluetooth trademarks are owned by their proprietor and used by Binatone Electronics International LTD. under license.

Connect to Cell™ is a trademark of VTech Communications, Inc.

All other trademarks are the property of their respective owners.

© 2017 Motorola Mobility LLC. All rights reserved.

US_EN Version

