



at&t

User's manual

2.4 GHz Cordless Telephone E2803B

with caller ID/call waiting



Congratulations on your purchase
of this AT&T product.

Important! Before using this telephone, you
must read the **Important safety instructions**
on pages 40 to 42 of this manual.

NEED HELP?

Our representatives are here
to help you with any questions concerning
the operation of this product, available
accessories,
or any other related issues.

Call toll free

1 (800) 222-3111

In Canada, call

1 (866) 288-4268

or visit our web site at

www.telephones.att.com

Model #: E2803B

Type: 2.4GHz cordless telephone

Serial #: _____

(found on the bottom of the telephone base)

Purchase date: _____

Place of purchase: _____

IMPORTANT

Information about caller ID with call waiting

This product has a caller ID function with call waiting feature which works with service from your local telephone company.

Caller ID with call waiting lets you see the name and telephone number of the caller before answering the telephone, even when on another call.

You may be necessary to change your telephone service to use this feature. Contact your telephone company if:

- You have both caller ID and call waiting, but as separate services (you may need combined service).
- You have only caller ID service, or only call waiting service.
- You do not have any caller ID or call waiting services.

This product can be used with regular caller ID service, or this product's other features can be used without subscribing to either caller ID or combined caller ID with call waiting service.

There are fees for caller ID services, and they may not be available in all areas.

Depending on your service, caller's number, or the caller's name and number may be displayed. This product can provide information only if both you and the caller are in areas offering caller ID service, and if both telephone companies use compatible equipment. The time and date are sent by your local telephone company along with the call information.

Information about telephone base installation

This power adapter is intended to be correctly oriented a vertical or floor mount position.

You must install and charge the battery before using the telephone.



See page 8 for easy instructions.

For customer service or product information, visit our web site at **www.telephones.att.com** or call **1 (800) 222-3111**. In Canada, call **1 (866) 288-4268**.



CAUTION: To reduce the risk of fire or injury to persons or damage to the telephone, read and follow these instructions carefully:

- Use only replacement battery model 27910 (part number 89-0099-00-00).
- Do not dispose of the battery in a fire. Like other batteries of this type, it could explode if burned. Check with local codes for special disposal instructions.
- Do not open or mutilate the battery. Released electrolyte is corrosive and may cause damage to the eyes or skin. It may be toxic if swallowed.
- Exercise care in handling batteries in order not to create a short circuit. Do not allow conductive materials such as rings, bracelets, or keys to touch the battery. The battery or conductor may overheat and cause harm.
- Charge the battery provided with or identified for use with this product only in accordance with the instructions and limitations specified in this manual.
- Observe proper polarity orientation between the battery and battery charger.

Do not disassemble your telephone. There are no user-serviceable parts inside. Refer to qualified service personnel for servicing.

User's manual

2.4 GHz Cordless Telephone E2803B

with caller ID / call waiting



Table of contents

Getting started

Quick reference guide	2
Parts checklist	4
Before you begin.....	5
Telephone base installation.....	6
Battery installation & charging.....	8
Wall mounting.....	9
Belt clip & optional headset.....	10

Telephone operation

Basic operation	11
Options while on calls.....	13
Intercom calls	15
Call forward	16
Call transfer.....	17
Handset settings	18

Directory

Directory	22
New directory entries	23
Directory search	25
To dial, edit or delete entries.....	26

Caller ID operation

Caller ID operation.....	28
To review the call log.....	30

Appendix

Screen icons, indicator lights & tones.....	32
Handset display screen messages.....	33
Troubleshooting.....	35
Important safety instructions.....	40
FCC Part 68 and ACTA.....	43
FCC Part 15.....	45
Limited warranty	46
Technical specifications.....	49
Index.....	50

Quick reference guide

Cordless handset

▼ CID/- VOLUME

Press to scroll down while in menus. Press to display caller ID information (see page 30). While entering names or numbers, press to move the cursor to the left (see page 24). Press to decrease the listening volume while on a call (see page 13).

PHONE/FLASH

Press to make or answer a call. During a call, press to receive an incoming call if call waiting is activated (see page 13).

MUTE/DELETE

While on a call, press to mute microphone (see page 14). While reviewing the call log, press to delete an individual entry, or press and hold to clear the caller ID log (see page 31). While entering or editing a name or number, press to delete a character (see page 23).

▶ SPEAKER

Press to activate handset speakerphone. Press again to resume normal handset use (see page 11).

MENU/SELECT

Press to display menu, or to select a displayed item from menu or save an entry.

DIR ▲ VOLUME+

Press to scroll up while in menus. Press to display directory entries (see page 25). While entering names or numbers, press to move the cursor to the right (see page 24). Press to increase the listening volume while on a call (see page 13).

OFF/CLEAR

During a call, press to hang up. While using menu, press to cancel an operation, back up to the previous menu, or exit the menu display. While pre-dialing, press to delete digits (see page 11).

REDIAL/PAUSE

Press to view redial memory (see page 12). While entering numbers, press and hold to insert a dialing pause (see page 23).

INT

Press to initiate an intercom conversation. Press to transfer or forward a call (see pages 15-17).

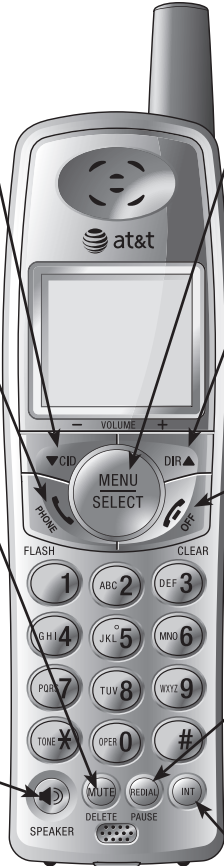

Feature menu



Menu

Feature menu

- DIRECTORY See page 22
- CALL LOG See page 28
- RINGER VOLUME . See page 18
- RINGER TONE..... See page 19
- KEY TONE See page 19
- LANGUAGE..... See page 20
- CLR VOICE MAIL... See page 21
- DIAL TYPE See page 21

Press ▼ CID/-VOLUME OF DIR ▲ VOLUME+ to scroll through menu items.

Press **MENU/SELECT** to select or modify a displayed item.

Press **OFF/CLEAR** to cancel an operation, back up to the previous menu, or exit the menu display.

Quick reference guide

Telephone base



CHARGE/IN USE

On when the cordless handset is properly positioned to charge in the telephone base.

Flashes during an incoming call's ringing.

Flashes when handset is in use, or when another telephone on the same line is in use.

VOICEMAIL

Flashes when there are new voicemail (requires voicemail service from your local telephone company).

HANDSET LOCATOR

Press to make handsets beep (see page 14).

Parts checklist

Save your sales receipt and original packaging in case it is necessary to ship your telephone for warranty service.

Check to make sure the telephone package includes the following:



Cordless handsets



Telephone base



Chargers for cordless handset



Batteries for cordless handsets



Battery compartment covers



Power adapter for telephone base

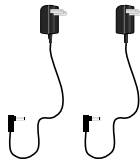

Power adapters for handset charger



Belt clips for cordless handsets



Telephone line cord

Before you begin

About caller identification

Caller ID with call waiting features in this telephone let you see the name and telephone number of the caller before answering the call, even when on another call. These features require services provided by your local telephone company.

Contact your telephone company if:

- You have both caller ID and call waiting, but as separate services (you may need combined service).
- You have only caller ID service, or only call waiting service.
- You do not have any caller ID or call waiting services.

You can use this telephone with regular caller ID service, or you can use its other features without subscribing to either caller ID or combined caller ID with call waiting service. There may be fees for these services, and they may not be available in all areas.

Caller ID features will work only if both you and the caller are in areas offering caller ID service, and if both telephone companies use compatible equipment.

See caller ID operation, beginning on page 28, for more details about how these features work.

Telephone operating range

This cordless telephone operates with the maximum power allowed by the Federal Communications Commission (FCC). The handsets and telephone base can communicate over only a certain distance — which can vary with the locations of the telephone base and handset(s), the weather, the layout, and the construction of your home or office.

If there is a call while the handset is out of range, the handset might not ring — or if it does ring, the call might not connect when you press **\PHONE/FLASH**. Move closer to the telephone base, then press **\PHONE/FLASH** to answer the call.

If the handset is moved out of range during a telephone conversation, there may be noise or interference. To improve reception, move closer to the telephone base.

Telephone base installation

Choose a central location close to a telephone jack and a power outlet not connected to a wall switch. The telephone base can be placed on a flat surface or mounted on a standard wall plate. For optimum range and better reception, place the telephone base in a high and open location.

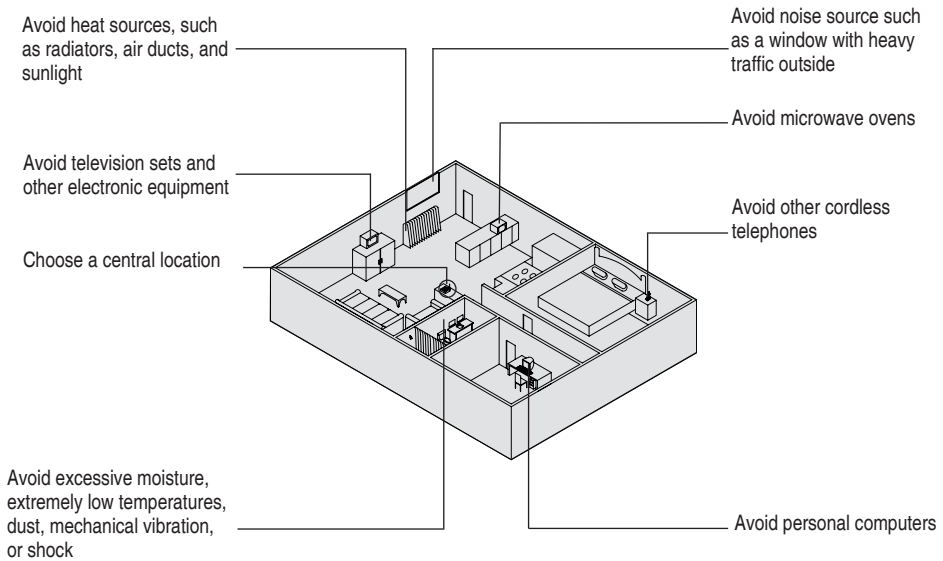

Avoid placing the telephone base too close to:

- Communication devices such as: personal computers, computer routers, television sets, VCRs, wireless routers (wireless broadband, wi-fi, or 802.11), other cordless telephones, etc.
- Excessive heat sources such as radiators, ventilation ducts, and direct sunlight.
- Noise sources such as a window with traffic outside, motors, microwave ovens, refrigerators, and fluorescent lighting.
- Excessive dust sources such as: a workshop, garage, etc.
- Excessive moisture such as the bathroom, kitchen, sauna, or greenhouse.
- Extremely low temperatures such as the garage.
- Mechanical vibration or shock such as on top of the washing machine or on a work bench.

Telephone base installation

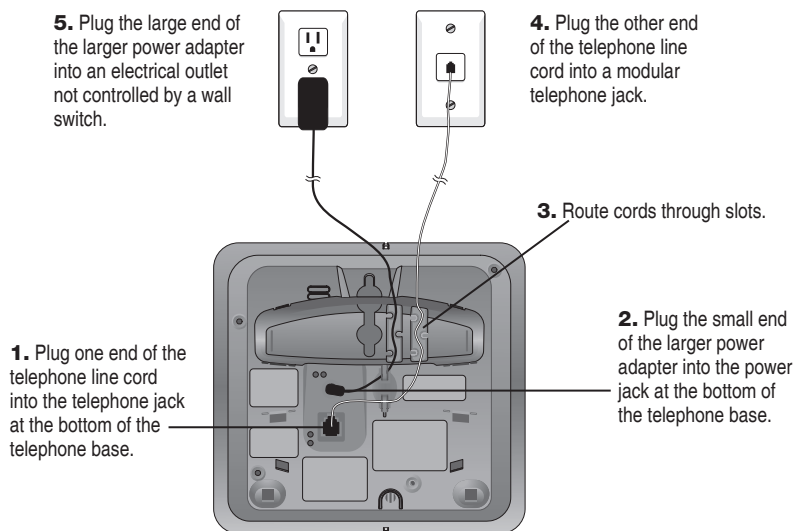

NOTES:

1. Use only the power cord supplied with this product. If you need a replacement, call 1 (800) 222-3111. In Canada, call 1 (866) 288-4268.
2. Be sure to use an electrical outlet not controlled by a wall switch.
3. This power adapter is intended to be correctly plugged into a vertical wall outlet, or a floor outlet, or a horizontal/vertical power strip/bar. The prongs are not designed to hold the plug in place if it is plugged into a ceiling outlet.

Battery installation & charging

After battery installation, the battery may have enough charge to allow you to make a short call. For best performance, place the handsets in the telephone base or a charger and allow to charge for 16 hours before use. You can keep the battery charged by returning the handsets to the telephone base or chargers after use. When the battery is fully depleted, a recharge takes about 12 hours. The average talk time on a fully charged battery is about eight hours and the standby time is approximately five days. Actual battery life depends on usage conditions and age of battery.

1. Plug the small end of the smaller power adapter into the jack on the underside of charger, then route the cord through the slot as shown.

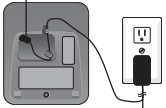

Plug the large end of the smaller power adapter into an electrical outlet not controlled by a wall switch.



2. Insert the plug as indicated. Be sure to securely insert the plug, making sure it matches the color-coded label inside the battery compartment.



3. Place the battery and wires inside the compartment.



4. Slide the battery compartment cover up until it clicks.



5. The battery may have enough charge to allow you to make a short call. For best performance, place the handset in telephone base or charger to charge for at least 16 hours before first use.

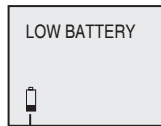

Low battery indicator
Return the handset to the telephone base or charger to recharge when this symbol flashes. (Handset will beep when battery is low.)



To replace the battery, press in and downward on the tab of the battery compartment cover to open the battery compartment cover. Lift out the old battery and disconnect it from the handset. Follow the instructions on this page to install and charge the new battery.

 **Caution:** Use only the supplied rechargeable battery or replacement battery model 27910 (part number 89-0099-00-00).

Wall mounting

The telephone base comes with the bracket mounted for tabletop use. If wall-mounting is desired, follow the directions below.

1. To remove the bracket, hold the telephone base in both hands, press the two bracket tabs and lift the bracket away from slots ㉑ and ㉒.

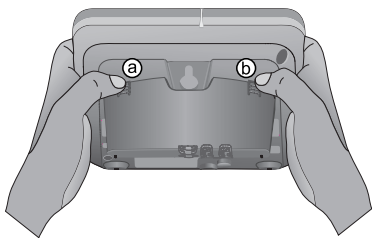

2. Connect the telephone line cord and power adapter to the jacks on the bottom of the telephone base. Wrap the cords as shown. Put the telephone line into the bracket.

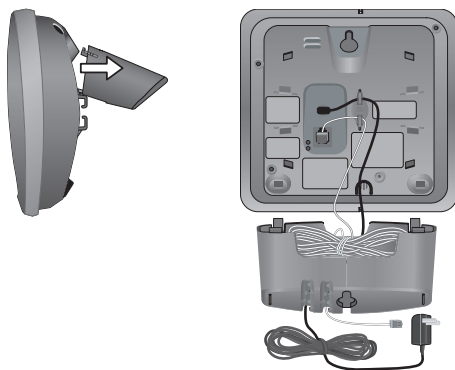

3. To attach the bracket for wall mounting, insert the tabs of the bracket into the slots ㉓ and ㉔ on the telephone base, then press the other bracket tabs into slots ㉕ and ㉖ as shown on the right.

4. Plug the power adapter into an electrical outlet not controlled by a wall switch. Plug the telephone line cord into a telephone wall jack. To mount the telephone on the wall, position the mounting holes ㉗ and ㉘ over the wall outlet mounting pegs. Press and slide the bracket down firmly so the telephone is held securely on the telephone outlet mounting pegs.

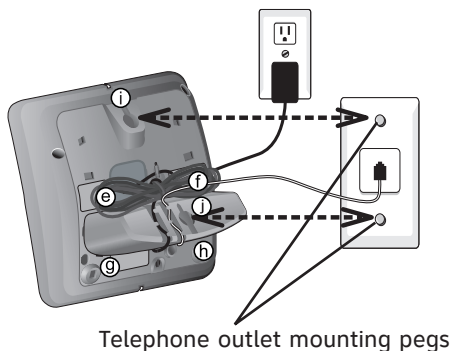

NOTE: To change back to tabletop mounting, remove the telephone base from the wall and remove the bracket from the telephone base (see step 1). Unplug the cords from the wall jacks. Insert the bracket tabs into the slots ㉑ and ㉒ on the telephone base, then press the other bracket tabs into the slots ㉓ and ㉔. Connect the telephone line cord and power adapter (see page 7).

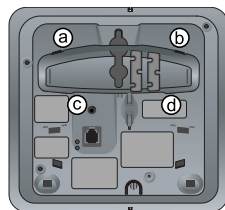

Belt clip & optional headset

Install belt clip as shown (optional).

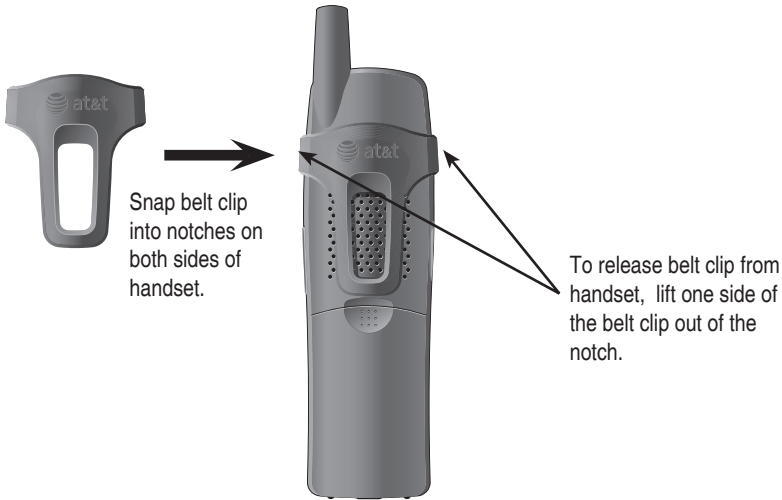

For hands-free telephone conversations, use any industry standard 2.5 mm headset (purchased separately). For best results, use an AT&T 2.5 mm headset.

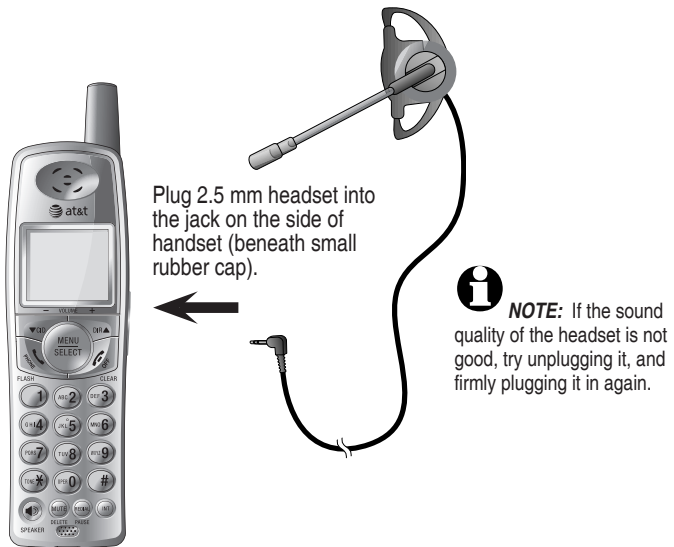

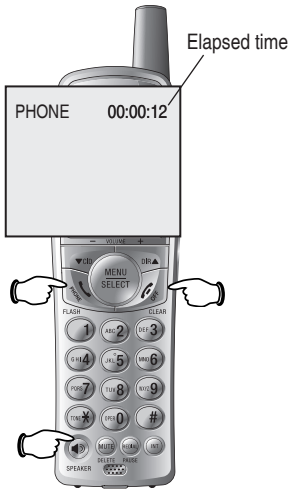

Basic operation

Making and answering calls

To answer an incoming call, press **PHONE/FLASH** or **SPEAKER**, or any dial pad key (0-9, * or #) on the handset. To make a call, press **PHONE/FLASH** or **SPEAKER**, then dial a number. Press **OFF/CLEAR** or place the handset in the telephone base or charger to hang up.

To preview numbers before dialing, enter numbers first. Press **MUTE/DELETE** or **OFF/CLEAR** anytime to make corrections. Then press **PHONE/FLASH** or **SPEAKER** to dial.

The screen displays the elapsed time as you talk (in hours, minutes and seconds).



NOTE: Pressing **PHONE/FLASH** to access service from your local telephone company will not affect the elapsed time.



Hands-free speakerphone calls

To answer a call, press **SPEAKER**. To make a call, press **SPEAKER**, then dial a number. During a call, press **SPEAKER** to toggle between hands-free speakerphone and normal handset use. Press **OFF/CLEAR** to hang up.



NOTE: When the headset is plugged in the handset, the hands-free speakerphone can not be activated. Make sure the headset is unplugged, then press **SPEAKER** to activate the hands-free speakerphone.

Basic operation

Last number redial

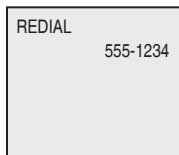

Press **REDIAL/PAUSE** to display the most recently called numbers (up to 32 digits). Use the **▼CID** or **DIR▲** or **REDIAL/PAUSE** repeatedly to view up to five recently called numbers. The handset beeps twice at the beginning or end of the list. Press **OFF/CLEAR** to exit.

Press **PHONE/FLASH** or **SPEAKER** to redial any displayed number. Or press **PHONE/FLASH** then **REDIAL/PAUSE** to dial the most recently called number (up to 32 digits).

Press **MUTE/DELETE** to delete the displayed number from the redial memory.

Handset locator

If the handsets are misplaced, press **HANDSET LOCATOR** at the telephone base. This triggers the paging tone at the handsets for 60 seconds to help to locate it. To stop the paging tone, press **PHONE/FLASH**, **SPEAKER**, or any dial pad key (0-9, *, or #) on the handsets, or press **HANDSET LOCATOR** on the telephone base.



NOTES:

1. The handset ringer volume also determines the level of the paging tone. If the handset ringer volume level is set to off (0), that handset will be silenced for all incoming calls and paging (see page 18).
2. During a page, if you press **OFF/CLEAR** or **MUTE/DELETE** on a handset (see page 14), the ringer of that handset will be silenced. But the page will not be cancelled.



Options while on calls

Volume control

Press **▼CID/-VOLUME** OR **DIR▲/VOLUME+** to adjust listening volume. Each button press adjusts volume by one level.

When changing the volume level, the new setting is saved.



NOTE: The hands-free speakerphone and headset listening volume are adjusted separately.

Call waiting

If you subscribe to call waiting service with your local telephone company, there will be a beep if there is an incoming call while you are already on a call. Press **PHONE/FLASH** to put your current call on hold and take the new call. Press **PHONE/FLASH** anytime to switch back and forth between calls. For more information on caller ID, see page 5.

Three-way conference calls

While on a call, a person on another handset can press **PHONE/FLASH** or **SPEAKER** to join the same conversation.

A person on either handset can press **OFF/CLEAR**, or place the handset in the telephone base or charger to drop out of the conference call, but the call will not be terminated until all handsets hang up.

Only two handsets are allowed to connect to an external call at the same time.

Options while on calls

Mute

Press **MUTE/DELETE** to silence the microphone. You will be able to hear the caller, but your caller will not be able to hear you until you press **MUTE/DELETE** again and resume speaking.



Temporary ring silencing

Press **OFF/CLEAR** or **MUTE/DELETE** while the telephone is ringing to silence the ringer temporarily. This will silence the ringer without disconnecting the call.

The next incoming call will ring normally.



NOTE: All handsets will ring with an incoming call. Pressing **OFF/CLEAR** or **MUTE/DELETE** on one handset will only silence the ringer of that particular handset but the other handsets will continue to ring.

Temporary tone dialing

If you have dial pulse (rotary) service only and have changed the telephone to pulse dial type (see page 21), you can temporarily switch to touch tone dialing during a call by pressing **TOUCH TONE**. This can be useful when sending tone signals for access to answering systems or long-distance services.

After you hang up or press **PHONE/FLASH** (to receive a call waiting call), the telephone automatically returns to dial pulse (rotary) service.

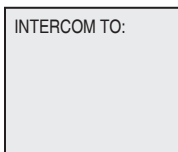

Intercom calls

You can use the intercom feature to have conversations between the handsets.

1. Press the **INT** button on a handset.
2. The display will read **INTERCOM TO:**
3. Enter the destination handset number. The display will read **CALLING HS #X.**
4. The destination handset will ring and its screen will display **INTERCOM CALL.**
5. Press **INT**, **PHONE/FLASH**, **SPEAKER** or any dial pad key (0-9, *, or #) on the destination handset to answer the call.



NOTES:

1. Pressing **INT** while on an external call will initiate call transfer (see page 17).
2. While a handset is in the directory or call log, or out of range, the intercom feature cannot be used.
3. If the destination handset does not answer the intercom call within 100 seconds, the originating handset will show **UNABLE TO CALL.**

To end the intercom call:

- Press **OFF/CLEAR** or **INT** on either handset.
-OR-
- Place either handset in the charger or telephone base.

Handling incoming calls

The phone will beep if there is an incoming external call during an intercom conversation. You can either:

- Press **PHONE/FLASH** to end the intercom call and answer the incoming call.
-OR-
- Press **INT** or **OFF/CLEAR** to disconnect the intercom connection without answering the incoming call. The incoming call will continue to ring.



FORWARD TO:

Call forward

During a conversation, an external call can be forwarded from one handset to another handset.

1. Press and hold **INT. FORWARD TO:** will be displayed on the screen of the originating handset.
2. Enter the destination handset number to forward the call. The display will show **CALL FORWARDED.**
3. The destination handset will ring and its screen will display **INCOMING CALL.**
4. Press **\PHONE/FLASH**, **SPEAKER** or any dial pad key (0-9, * or #) on the destination handset to answer the call.



NOTES:

1. When in a three-way conference call, the call forward feature cannot be used.
2. If the forwarded call is not answered within 30 seconds, the external call will be returned to the originating handset, and its display will show **CALL BACK.** Press **\PHONE/FLASH** to cancel the call forward function and resume the external call. If the returned call is not answered by pressing **\PHONE/FLASH** within an additional 30 seconds, the external call will be disconnected automatically.

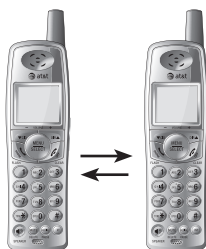

TRANSFER TO:

Call transfer

During a conversation, a call can be transferred to another handset.

1. Press **INT** to put the external call on hold. The screen on the originating handset will display **TRANSFER TO:**
2. Enter the destination handset number to transfer the call. The display will show **CALLING HS #X**.
3. The destination handset will ring, showing an intercom call. The display will show **INTERCOM CALL**.
4. Press **PHONE/FLASH**, **INT**, **SPEAKER** or any dial pad key (0-9, * or #) on the destination handset to answer the intercom call.
5. When the recipient answers the intercom call, you can talk privately without the external caller hearing the conversation.
6. On the originating handset, press **OFF/CLEAR** to transfer the call. The display will show **CALL TRANSFERRED**, and the recipient will automatically be connected to the external call.



NOTES:

1. When in a three-way conference call, the call transfer feature cannot be used.
2. If the recipient does not answer the intercom call, the person at the originating handset can press **PHONE/FLASH** to cancel the transfer function and resume the external call.
3. If the recipient does not answer the intercom call within 100 seconds, the originating handset will show the message **UNABLE TO CALL** then continue the external call automatically.
4. When the intercom call is answered, the originating party can toggle between the intercom and the external call by pressing **INT**. The display will show **INTERCOM** and **OUTSIDE** to indicate the current destination party (external or intercom call).