

# vtech GEMINI

## 2.4GHz Digital Cordless Phone System

### User Manual

Important:

This user manual contains safety precautions!

Please read carefully before putting the telephone into operation, and store in a safe place.



## Safety precautions

This cordless telephone is designed for transmitting voice calls over the analogue telephone network. Any other use whatsoever is not permitted and is regarded as in violation of the provisions. The user manual with safety precautions is a part of the product package and must be passed on to the new owner on reselling.

### Caution!

Use only approved rechargeable nickel-metal-hydride (Ni-MH AAA 600mAh) batteries. Using other rechargeable batteries or non-rechargeable batteries/primary cells can be dangerous and may cause malfunctions in or damage to the telephone. The manufacturer accepts no liability in this event.

Refer to chapter "Putting the handset into operation" for instructions on how to properly insert the batteries.



Please note that the ringtone for incoming calls as well as alert tones, are also emitted on the handset. Do not therefore hold the handset close to your ear while one of these functions is on, otherwise your hearing may be affected.

### Please note:

- ⇒ Do not immerse batteries in water or throw in the fire.
- ⇒ Rechargeable batteries can become warm while recharging. This is a normal occurrence and is not dangerous.
- ⇒ Do not use any other type of charging unit since this may damage the battery cells.
- ⇒ Before using the telephone, **wearers of hearing aids** should note that radio signals can be picked up by the hearing aid and cause an unpleasant buzzing noise.
- ⇒ Do not use your cordless telephone in environments at risk from explosion (e.g. paintworks, petrol stations etc.)
- ⇒ Do not position the base station/charging bay in bathrooms or showers.
- ⇒ The radio signals may affect the functioning of medical equipment.
- ⇒ In the event of a power cut or if the batteries are discharged, your cordless telephone will not function!
- ⇒ The handset must not be charged up without battery cells or the battery cover.
- ⇒ Never touch exposed contacts!
- ⇒ Use only the supplied SNG 04-ea power pack plug for the base station and charging unit.

### Disposal

Please dispose of the batteries, base station, handset, charging unit and power pack in an ecological manner. If in doubt consult your local council.

# Setting up the telephone

## Location

To obtain the best possible range, we recommend positioning the telephone in a location central to your sphere of activity. Avoid positioning the telephone in niches, recesses and behind steel doors.

The maximum range between the base station and handset is approximately 300 metres. Depending on the surrounding conditions as well as spatial and structural factors, the range may be smaller. The indoor range is normally shorter than outdoors. Depending on the structural surroundings, radio dead spots may occur even within the range due to digital transmission in the frequency range used. In this case the transmission quality may be reduced through the increased incidence of short breaks in transmission. Normal transmission quality will be resumed if you move slightly out of the radio dead spot. When the range is exceeded, the connection will be broken unless you move back into range within ten seconds.

To avoid radio signal interference from other electronic equipment, we recommend that the base station/charging bay and handset are situated at the greatest possible distance (minimum 1 metre) from other equipment.

## Secure telephone conversations

While in a telephone conversation, the base station and handset(s) are connected through a radio channel. The base station is the interface between the telephone network and the handset. To prevent people from tapping your telephone calls or making phonecalls on your expense, the base station and handset(s) are continuously exchanging identification codes.

In case of non-matching identification codes, a connection with foreign handsets will not be set up.

## Setting up the base station / charging bay

- ⇒ Do not expose the base station / charging bay to direct sunlight.  
Protect the base station / charging bay against moisture. Do not position the telephone in rooms exposed to condensation, corrosive steam or excessive dust. Condensation can occur in cellars, garages, conservatories or sheds.  
The ambient temperature must be between 5 °C and 40 °C.

Position the base station / charging bay in a clean, dry and well-aired location. Choose a place which is stable, even and not subject to vibrations.

To avoid mutual interference, do not position the base station / charging bay in the immediate vicinity of electronic equipment such as hi-fi systems, office equipment or microwave ovens. Avoid positioning the telephone near heat sources such as heating elements or near obstacles such as metal doors, thick walls, niches and cupboards.

The base station / charging bay does not have a mains switch. For this reason the socket to which it is connected must be easy to access.

## Wall mounting

Your GEMINI is suitable for wall-mounting. Two screws and two dowels are provided for this purpose.

Place the dowels vertically at a distance of 90 mm from each other and insert the screws. Leave approximately 3 mm space between the screw head and the wall.

Hang the base station on the screws and connect it to the power supply and telephone connection.

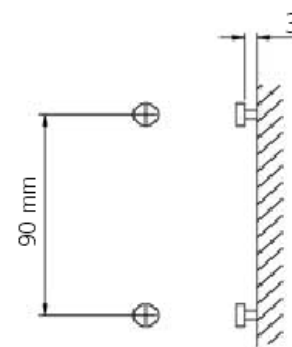

---

### Note

Please remember:

- The 110 V and telephone connection should be within range of the cable provided.
  - Please also note that the base station must not be mounted in the opening area of doors and windows: Danger of damage!
  - Caution: Take care not to damage leads in the wall!
-

## Connecting the telephone

Before you can start using your telephone you must plug in the telephone connection cords and the mains cable.

### Safety note

Use only the power pack provided for the base station/charging bay!

### ① Telephone connection cord

The telephone connection cord has two different plugs. Insert the smaller plug in the socket marked with the telephone symbol, and fit the cord into the corresponding cable groove.

Insert the larger plug in your telephone connection socket.

### ② Mains cable

First, insert the power cable in the socket marked with the power plug symbol on the base of the base station/charging bay, and fit the cable in the corresponding cable groove. Then insert the mains plug/adaptor in the 110V socket.

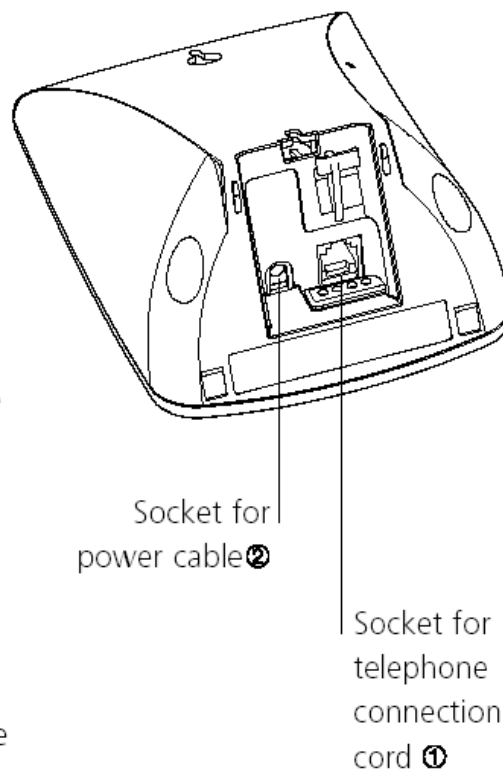

---

**Note** Your telephone will not function if the mains plug is not plugged in or during a power cut.  
This equipment is not designed for making emergency telephone calls when the power fails. Alternative arrangements should be made for access to emergency services.

---

## Removing the cords

First unplug the mains plug from the 110 V socket and the plug from the telephone connection socket.

To release the cord, use a ballpoint pen or similar object to press the holding hook towards the plug and simultaneously pull the plug out along with the cord.

## Putting the handset into operation

Your handset will be ready for operation (for making or accepting calls) only once the battery has been charged for the first time.

### Inserting the rechargeable batteries

The bottom of the handset contains a battery compartment for housing two type AAA batteries (microcells).

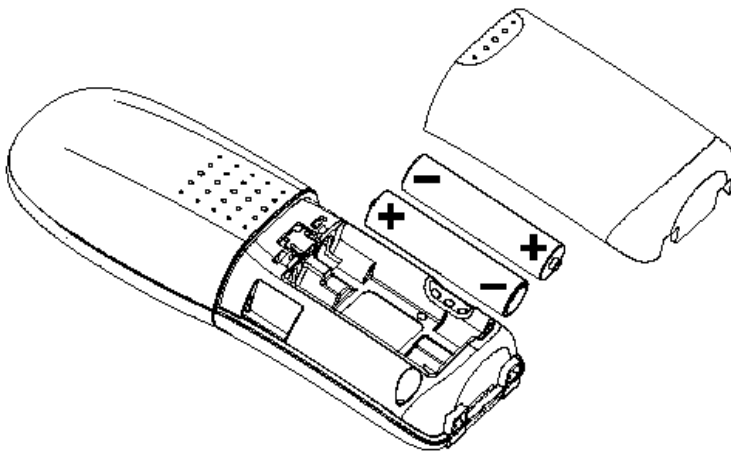

#### Removing the battery compartment cover:

Slide the battery compartment cover downwards (approx. 3 mm) and lift.

### Inserting the two rechargeable batteries (note the polarity!):

Insert the batteries in the battery compartment. Make sure the polarity is correct. Make sure to insert the batteries so that the flat end of the battery (the negative side) connects to the spring contact. The handset will not function if the batteries are incorrectly inserted. This may result in damage. Replace the compartment cover by placing it approximately 3 mm offset and slide it upwards until it clicks into place.

N,B use only the supplied Ni MH battery cells NEVER use non rechargeable or alkaline cells/ 'batteries'.

### Charging the batteries



The batteries are not yet charged when you first unpack the telephone. To charge the batteries, place the handset on the base station/charging bay. The flashing battery symbol on the handset signals the charging procedure. The batteries will take around 14 hours to charge up.

---

**Note**

- Do not place the handset in the charging bay if the batteries have not been fitted.
  - Do not use strange charging bays, the batteries can be damaged.
-

The following symbols indicate the charging status on the handset display:

-  Charging status "empty"
-  Charging status "1/2 "
-  Charging status "full"

Once the new batteries have been inserted, the display (1/2, full) on the handset indicates the actual charging status only after a complete charging procedure.

Insert the plug into your telephone connection socket once the battery symbol has stopped flashing.

Your telephone is now ready to use.

---

### **Important!**



Please note: The first time you insert the batteries, the battery display will indicate the correct information on the charging status only after a complete charging cycle. Use only NiMH rechargeable batteries. Never use disposable batteries/primary cells.

---

### **Note**

You can replace the handset in the base station/charging bay after every call. Charging is electronically controlled to ensure optimal charging of batteries in different charge states. Avoid removing the batteries from the handset for no good reason, since this affects the optimum charging cycle.

You can telephone for up to 10 hours with fully charged batteries.

If the battery charge status has reached its lower limit, the battery symbol () flashes in the display and a warning signal is heard. You have 10 minutes of talk time left.









---

# Display and keypad

## Display and symbols

The handset display provides easy to understand information on the current status of your telephone. The 4-line display (with backlight illumination) is capable of showing several graphical symbols and text lines. The meaning of the symbols shown in the upper part of the display is as follows:



-  ..... This antenna symbol is permanently lit if a radio connection between handset and base station exists. A blinking symbol shows that the handset is almost outside of the range of the corresponding base station.
-  ..... You have pressed the talk key.
-  ..... Indicates that the handset is logged on to base station A, B, C or D. Upon delivery the handset is logged on to base station A. Refer to page 48 for more information on selecting another base station.
-  ..... The keypad has been locked („key lock“).
-  ..... One or more new SMS<sup>1</sup> text message have been received.
-  ..... The ring tone has been switched off („do not disturb“). Incoming calls are signalled by a short beep.
-  ..... The microphone is switched off („mute“).
-  ..... Indicates charge status of the battery (refer to page **Error!** **Bookmark not defined.** for more information).
-  ..... Name and number of the handset. You can operate up to 5 handsets on the same base station. This allows you to make internal calls between handsets free of charge!

<sup>1</sup> Ask your service provider about the availability and any charges for this service.



## Handset front view

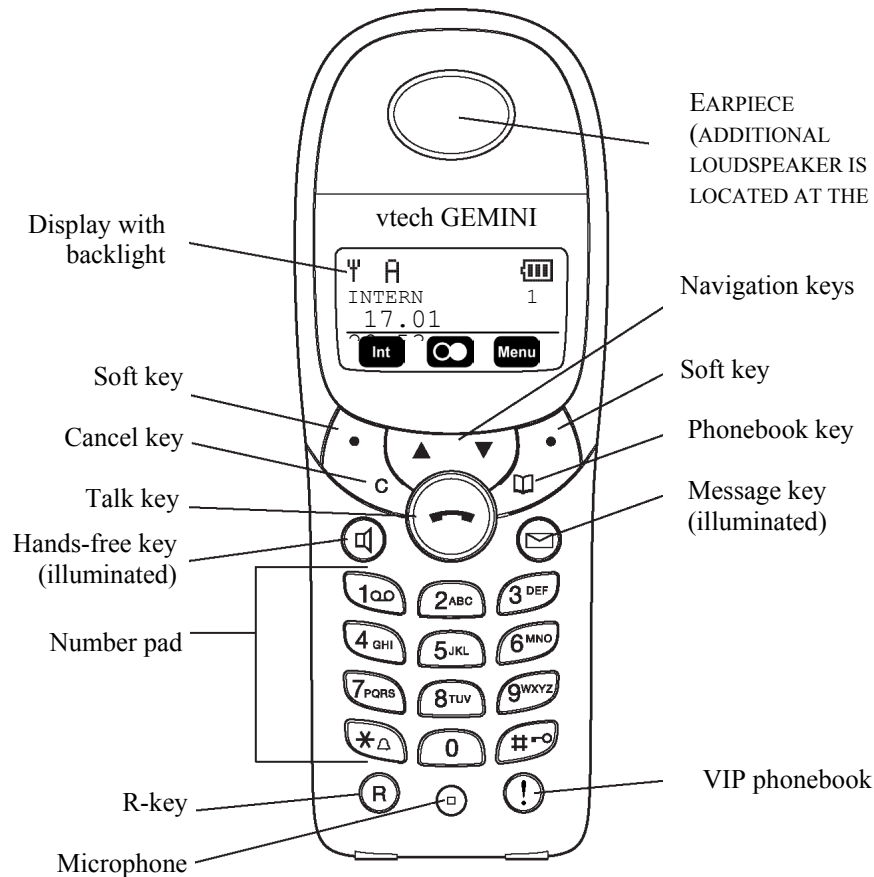

## Handset keypad

The following illustrations represent the keys on the handset keypad. For each key a short description is provided.



Softkeys (left and right) which corresponding to different functions as displayed on the screen.



The navigation keys have different functions:

- ⇒ While in a standby: open the redial list.
- ⇒ While in a menu: scroll up or down.
- ⇒ During a call: change the volume.



This C (cancel)-key has different functions:

- ⇒ While in a menu: press to quit the (sub) menu
- ⇒ Press for 2 seconds to return to the standby mode.
- ⇒ During a call: press to switch off the microphone (mute).



Open the phonebook.



Talk key. Corresponds to "lift/replace receiver" on a conventional telephone.



Handsfree / speakerphone: switch the loudspeaker on/off. When the loudspeaker is on, this key is illuminated.



Message key. This key blinks when one or more new messages have been received. Press this key to open the message list.



Numerical keys for entering telephone numbers as well as text.

- When pressing the 1-key for approx. 2 seconds (long-press), the network mailbox number is dialled directly.
- In dialling mode, when pressing the 0-key for approx. 2 seconds (long-press), a dialling pause is inserted between digits



Asterisk (or star) key to enter the “asterisk” symbol. Pressing this key and holding it for approx. 2 seconds switches the ring tone on/off. While editing names or writing text, pressing this key switches between uppercase and lowercase characters.



Hash (or pound) key to enter the “hash” symbol.

Pressing this key and holding it for approx. 2 seconds locks/unlocks the keypad.



Open the VIP phonebook.



R – or Flash key.

## Base station front view

The vtech GEMINI base station is equipped with a multi-functional paging key used for finding (paging) the handset(s) (see below) and registering handsets on to the base station (refer to page 11).

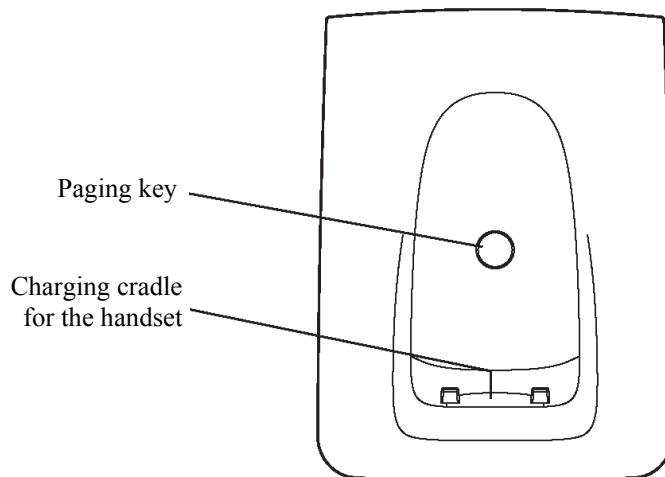

## Finding the handset (paging)

You can easily find a (misplaced) handset by pressing the paging key on the base station. All handsets which are logged on to this base station will start ringing for 60 seconds enabling you to quickly find the handset(s) again.

Stop the ring tone on the handset by pressing the talk key .

---

**Note** A handset will not start ringing if the handset is not registered to the base station. For more information how to register the handset to the base station refer to page 11. The handset will not ring if switched off or the batteries are flat.

---

# Making the first call

## Switching the handset on/off

After placing the handset in the base station (and completing the initial charging of the batteries) the handset is automatically switched on and ready for operation.

### Switching on the handset

If the handset happens to be off, you can switch it on again by pressing the talk key .

### Switching off the handset

You may switch off the handset in order to prolong the duration of the rechargeable batteries. Follow this procedure:

 Menu

Open the menu by pressing the «Menu» softkey.

Select the menu entry **Switch off HS** and press the «OK» softkey.

 OK

The display shows: **Switch off HS?** Press the «OK» softkey to switch off the handset.

---

#### Note

The handset does not respond to paging from the base station nor to incoming calls when it is switched off!

---

## Registering (Log on) the handset

The handset is initially already registered to the base station. In this case both the  $\Psi$  and  $\Pi$  symbols should be visible in the display. If for whatever reason the handset is no longer registered to the base station, the display will show **Please Log-on !**. In this case follow the registration procedure as described on page 47.

---



#### Note

With this vtech GEMINI you can operate up to 5 handset on the same base station. This allows internal calls between handsets (registered to the same base station) free of charge!

---

## Switching the key lock on/off

When carrying the handset with you, you may want to switch on the key lock. This prevents any calls be made unintentionally since all key functions are disabled.

Pressing the  key for approx. 2 seconds will lock/unlock the keypad. When the keys are locked, the display shows **Key lock on !** as well as the  symbol.

---

#### Note

- Even when the key lock is on, you can answer any incoming call simply by pressing the talk key .
  - You can always dial any of the predefined emergency numbers, even when the key lock is on.
- 

## Set the time and date

Before you make your first phone call you may want to set the correct time and date. Please follow the procedure described on page 42.

## Make a telephone call

Now you are ready to make your first telephone call:

Lift the handset from the base station.



Press the talk key. You will hear the dial tone and the talk icon appears on the screen: 



Enter the telephone number. After entering the last digit, the telephone connection is being made and you will hear the ring tone. As soon as the other party picks up the phone, you can start your conversation.

Alternatively you may follow these steps:

Lift the handset from the base station.



Enter the telephone number. You may correct the entry by pressing the cancel key  which deletes the last digit.



Press the talk key. The Vtech GEMINI will send the telephone number to the network. After the connection is established you will hear the ring tone.

---

#### Note

- Your Vtech GEMINI supports the entry of telephone numbers with a maximum of 24 digits. When entering more than 16 digits the additional digits are displayed on the second line of the display.
  - Your Vtech GEMINI offers several other means to dial telephone numbers (e.g. using the phonebook. For details refer to page 14.
  - You may also make internal calls. Refer to page 21 for more details.
- 

## Answering a telephone call

When someone is calling you, you will hear the ring tone and the number (or name) of the calling party is displayed on the Vtech GEMINI handset. Not all service providers support this so-called CLIP service. So ask your service provider about the availability and additional charges of service.

To answer a telephone call you simply lift the handset from the base station or you press the talk key .

---

#### Note

- Your Vtech GEMINI handset displays the name of the calling party (instead of the telephone number) only if you have previously entered this telephone number in the phonebook.
  - The calling party may have restricted its identity. In this case the name or number will not be shown. The display will simply read: **Incoming Call !**
  - Incoming calls are signalled acoustically on both the handset and the base station. You may change the volume and melody of these ring tones individually (refer to pages 37 and 41).
- 

## Ending a telephone call

To end a telephone call you simply press the talk key  and the telephone connection is broken. The handset returns to the standby mode.

## Missed calls

If you had one or more unanswered calls during your absence the handset display shows **New calls !** In addition, the message key  is blinking to indicate that you missed one or more calls.

Press the message key  to open the Call Log to see who called you. Refer to page 19 for more information on the Call Log and its features.

## Handsfree calling

The Vtech GEMINI handset is equipped with a loudspeaker which enables handsfree calling. Press the loudspeaker key  on the handset to activate/deactivate the loudspeaker.

The loudspeaker key is illuminated when the loudspeaker is activated.

The volume of the earpiece and of the loudspeaker can be adjusted independently (refer to page 13).



### Warning !

The loudspeaker is located at the **backside** of the handset and may produce loud tones. **Never** place the loudspeaker close to your ear in order to prevent hearing damage !

---

## Changing the voice volume during a call

During a call you can independently adjust both the earpiece and loudspeaker voice volumes in five levels.



You are conducting a telephone conversation.



Press the «Volume» softkey.



The current setting is indicated by a tick mark. Select the desired volume level with the navigation keys (1 - 5).

When handsfree is off you can adjust the earpiece volume:

`Earpiece Vol.1` ✓ = quietest level (1)

`Earpiece vol.5` = loudest level (5)

When handsfree is on you can adjust the loudspeaker volume:



`Speaker Vol.1` ✓ = quietest level (1)

`Speaker vol.5` = loudest level (5)



Confirm with the «OK» softkey. The new voice volume level is set.

## Muting the handset



If you are in a telephone conversation with someone and you don't want that person to hear what is being said in the room then you can temporarily switch off the microphone of the handset („mute“) by pressing . The  icon appears in the display to indicate that the microphone is switched off. Press  again to switch the microphone back on.

# Message Lists



Your Vtech GEMINI has three different message lists:

- **Network Mailbox**

This list shows whether you have new messages in your network mailbox (only if available from your service provider!). This network mailbox works like an answering machine similar to what is often used for GSM mobile phones.



When you have one or more message in this network mailbox the display shows **Mailbox !** and the message key  is blinking. By pressing this message key  you can call your mailbox directly to listen to the new message(s). Refer to page 45 for more information on availability and operation.

- **SMS Messages**

For SMS messages actually two lists are available: one for incoming and one for outgoing (stored) messages. ). When you have one or more new SMS messages the display shows **New SMS !** and the message key  is blinking. By pressing this message key  you enter the list of incoming SMS messages directly.

Refer to page 30 for more details on SMS messages.

- **Call Log**

This list contains previous incoming calls (both answered and unanswered). When you have missed one or more calls the display shows **New calls !** and the message key  is blinking. By pressing this message key  you enter the Call Log directly.

For more information on the Call Log and its features refer to page 19.

---

**Note**

- You can access the message lists by pressing the message key  or by selecting the menu entry **Messages** from the main menu.
  - If several new message (of different types) are available then the display shows **Message waiting**
-

# Comfort dialling

## Dialling using the phonebook

Instead of remembering a telephone number, you can lookup a name in the phonebook and dial the corresponding telephone number with a single key press.



Press the phonebook key. The first entry in the phonebook is displayed. The number of entries currently stored in the phonebook is displayed at the top of the display, e.g. **Phonebook (23)**



Scroll to the desired phonebook entry using the navigation keys.



Alternatively, you may use the number keys (0 - 9) to enter the first character of the desired name e.g.:

Press **5<sub>JKL</sub>** once to jump to the first entry starting with the letter "J".

Press **4<sub>GHI</sub>** twice to jump to the first entry starting with the letter "H".



Press the talk key. The corresponding telephone number is dialled.

---

### Note

After you have located the desired phonebook entry you may press the «OK» softkey which allows you to edit or extend this telephone number before dialling.

---

## Managing the phonebook

The handset of your Vtech GEMINI stores up to 60 entries in the phonebook. For each entry you can specify the telephone number (max. 24 digits) and the corresponding name (max. 15 characters).

### Creating a new entry in the phonebook



Press the phonebook key to open the phonebook.



Open the phonebook administration menu by pressing the «Options» softkey.



Select the menu entry **New entry** and press the «OK» softkey.



The display reads **Enter number:** Enter the telephone number and finish by pressing the «OK» softkey. For details on how to enter special characters see below.



The display reads **Enter name:** Enter the corresponding name and finish by pressing the «Store» softkey. The display briefly shows **Entry stored !**. The entry is now stored in the phonebook.











Press the cancel key for approx. 2 seconds to return to the standby mode.

## Entering Special Characters







---

- Note**
- Special characters can be entered in the telephone numbers and stored in the phonebook. Examples are **\***, **#**, **P** (dial pause) and **R** (flash).
  - Enter a dial pause by pressing the **0** key for approx. 2 seconds.
  - Enter a flash by pressing the flash key **R**. For details on setting the length of the flash signal, please refer to page 42.
  - Correct entries by deleting the last digit/character by pressing the «Delete» softkey **←**.
  - The available characters for entering names are listed on page **Error! Bookmark not defined.**. Press **\*Δ** to toggle between uppercase, lowercase or digit characters.
- 

## Editing entries in the phonebook

-  Press the phonebook key. The first entry in the phonebook is displayed.
-  Scroll to the desired phonebook entry using the navigation keys.
-  Open the phonebook administration menu by pressing the «Options» softkey.
-  Select the menu entry **Edit entry** and press the «OK» softkey.
-   The display shows the telephone number of this entry. Edit this number and finish by pressing the «OK» softkey.
-   The display shows the corresponding name. Edit this name and finish by pressing the «Store» softkey. The display briefly shows **Entry stored !**. The changes are now stored in the phonebook.
-  ..... Press the cancel key for approx. 2 seconds to return to the standby mode.

## Deleting entries from the phonebook



-  Press the phonebook key. The first entry in the phonebook is displayed.
  -  Scroll to the desired phonebook entry using the navigation keys.
  -  Open the phonebook administration menu by pressing the «Options» softkey.
  -  Select the menu entry **Delete entry** and press the «OK» softkey.
  -  The display reads **Delete entry?** Press the «Yes» softkey to confirm. The display briefly shows **Entry delete !** and the entry is deleted from the phonebook.
  -  ..... Press the cancel key for approx. 2 seconds to return to the standby mode.
- 

- Note**
- The phonebook is stored in the handset. Any changes in the phonebook are thus not seen in other handsets which are logged on to the same base station.
  - The entire phonebook is cleared when you reset the handset (refer to page 38).
- 

## Dialling using the VIP phonebook

With the VIP phonebook key  you have access to a special phonebook with 7 names and telephone numbers.









-  Press the VIP phonebook key.
-  Scroll to the desired entry using the navigation keys.
-  Press the talk key. The selected telephone number is dialled.

**Note** This VIP phonebook is stored in the base station and thus is available to all handsets which are logged on to the base station.

## Managing the VIP phonebook







### Editing an entry in the VIP phonebook.

-  Press the VIP phonebook key.
-  Scroll to the desired entry using the navigation keys.
-  Press the «Options» softkey.
-  Select the menu entry **Edit entry** and press the «OK» softkey.
-  Edit the telephone number and finish by pressing the «OK» softkey. For details on how to enter special characters refer to page 16.
-  Edit the corresponding name and finish by pressing the «Store» softkey. The display briefly shows **Entry stored !**. The changes are now stored in the VIP phonebook.
-  Press the cancel key for approx. 2 seconds to return to the standby mode.

**Note** The VIP phonebook is stored in the base station. Any changes in the phonebook are thus also seen in other handsets which are logged in to the base station.

### Clearing entries from the VIP phonebook

The entries in the VIP phonebook cannot really be deleted (so that the following entries move up one position). Instead you can clear (empty) each entry individually.

-  Press the VIP phonebook key.
-  Scroll to the desired entry using the navigation keys.
-  Press the «Options» softkey.
-  Select the menu entry **Delete entry** and press the «OK» softkey. The display shows **Delete entry?**.
-  Confirm by pressing the «Yes» softkey. The display briefly shows **Entry deleted !**. The entry will appear in the VIP phonebook marked as **- Empty -**.
-  Press the cancel key for approx. 2 seconds to return to the standby mode.

## Quick Dial (Network Mailbox)

Your Vtech GEMINI offers a quick dial function for a network mailbox (voicebox). Such a network mailbox is a supplementary network service offered by your service provider, acting as an automatic answering machine.

Press **100** for 2 seconds and your Vtech GEMINI automatically dials the pre-programmed telephone number of this network mailbox. Refer to page 45 for more information on this network mailbox and how to use it.

- 
- Note**
- Please note that quick dialling is only supported for the **100** key.
  - Remember that this quick dial function is only used to access the network mailbox. To activate/de-activate the mailbox you must send appropriate network codes to this mailbox. Ask your service provider for details.
- 

## Redialling from the redial list

The last 20 dialled telephone numbers are stored in the redial list. Each subsequent dialled number overwrites the oldest entry in the list.

### Redial a telephone number

 Open the redial list by pressing the «Redial» softkey. The newest entry in the redial list is displayed. The number of entries currently stored in the redial list is displayed at the top of the display, e.g. **Redial list (15)**

 Scroll to the desired entry using the navigation keys.

 Press the talk key. The selected telephone number is redialled.

- 
- Note** After you have selected the desired redial number you may press the «OK» softkey which allows you to edit or extend this telephone number before redialling.
- 

## Managing the redial list

### Deleting entries from the redial list

 Press the «Redial» softkey. The first entry in the redial list is displayed.

 Scroll to the desired entry using the navigation keys.

 Open the redial list administration menu by pressing the «Options» softkey.

 Select the menu entry **Delete entry** and press the «OK» softkey.

 The display reads **Delete entry?** Press the «Yes» softkey to confirm. The display briefly shows **Entry delete !** and the entry is deleted from the redial list.

 Press the cancel key for approx. 2 seconds to return to the standby mode.

- 
- Note** The redial list is stored in the individual handset. Thus, all manipulations of the redial list (such as deleting an entry) will not be seen in other handsets which are logged on to the same base station.
- 

### Deleting the entire redial list

 Press the «Redial» softkey. The first entry in the redial list is displayed.

 Scroll to the desired entry using the navigation keys.

 Open the redial list administration menu by pressing the «Options» softkey.

 Select the menu entry **Delete list** and press the «OK» softkey.

 The display reads **Delete list?** Press the «Yes» softkey to confirm. The display briefly shows **List delete !** and the entire list is deleted.







 Press the cancel key for approx. 2 seconds to return to the standby mode.

---

**Note** The entire redial list is also deleted when the handset is reset (refer to page 38).

---

## Store number from the redial list in the phonebook

-  Press the «Redial» softkey. The first entry in the redial list is displayed.
-  Scroll to the desired entry using the navigation keys.
-  Open the redial list administration menu by pressing the «Options» softkey.
-  Select the menu entry **Store phonebook** and press the «OK» softkey.
-  The display reads **Enter name:** Enter the corresponding name and finish by pressing the «Store» softkey. The display briefly shows **Entry stored !**. The entry is now stored in the phonebook.
-  Press the cancel key for approx. 2 seconds to return to the standby mode.



## Dialling from the Call Log

If the CLIP service is supported by your service provider (i.e. if the telephone number of the calling party is made available) then any unanswered calls will be stored in the Call Log. This Call Log contains up to 20 entries. If the Call Log is full, then the newest entry overwrites the oldest one.





The handset display shows **New calls !** if you have any new unanswered calls. In addition, the message key  is blinking to indicate that you missed one or more calls.

### Dialling a telephone number from the Call Log

The handset display shows **New calls !**

-  Press the message key. The most recent unanswered call is displayed.
-  Scroll to the desired entry using the navigation keys.
-  Press the talk key. The corresponding telephone number is dialed.

or

-  Open the menu by pressing the «Menu» softkey.
-  Select the menu entry **Messages** and press the «OK» softkey.
-  Select the menu entry **Call Log** and press the «OK» softkey.
-  Scroll to the desired entry using the navigation keys.
-  Press the talk key. The corresponding telephone number is dialed.



---





**Note** With PBX telephone systems:  
Dialling from the Call Log works properly only if the PBX system automatically inserts first any required network access digit! Refer to the respective PBX user documentation for more information.

---









## Managing the Call Log

### Show details of an unanswered call







-  Press the message key.
-  Select the menu entry **Call Log** and press the «OK» softkey.

-  Scroll to the desired entry using the navigation keys.
-  Open the administration menu by pressing the «Options» softkey.
-  Select the menu entry **Show details** and press the «OK» softkey.  
The display shows the telephone number of the caller as well as the time/date of the call.
-  ..... Press the cancel key for approx. 2 seconds to return to the standby mode.

## Store number from the Call Log in the phonebook

-  Press the message key.
-  Select the menu entry **Call Log** and press the «OK» softkey.
-  Scroll to the desired entry using the navigation keys.
-  Open the administration menu by pressing the «Options» softkey.
-  Select the menu entry **Store phonebook** and press the «OK» softkey.
-   The display reads **Enter name:** Enter the corresponding name and finish by pressing the «Store» softkey. The display briefly shows **Entry stored !**. The entry is now stored in the phonebook.
-  ..... Press the cancel key for approx. 2 seconds to return to the standby mode.

## Deleting an entry from the Call Log







-  Press the message key.
-  Select the menu entry **Call Log** and press the «OK» softkey.
-  Scroll to the desired entry using the navigation keys.
-  Open the administration menu by pressing the «Options» softkey.
-  Select the menu entry **Delete entry** and press the «OK» softkey.
-  The display reads **Delete entry?** Press the «Yes» softkey to confirm. The display briefly shows **Entry delete !** and the entry is deleted from the Call Log.
-  ..... Press the cancel key for approx. 2 seconds to return to the standby mode.

---

**Note** The Call Log is stored in the base station. Thus, all manipulations of the Call Log (such as deleting an entry) will be reflected in all handsets which are logged on to the base station.

---

## Deleting the entire Call Log

-  Press the message key.
-  Select the menu entry **Call Log** and press the «OK» softkey.
-  Open the administration menu by pressing the «Options» softkey.
-  Select the menu entry **Delete list** and press the «OK» softkey.
-  The display reads **Delete list?** Press the «Yes» softkey to confirm. The display briefly shows **List delete !** and the entire list is deleted.
-  ..... Press the cancel key for approx. 2 seconds to return to the standby mode.

---

**Note** The entire Call Log is also deleted when the base station is reset (refer to page 43).

---

## Making internal calls

If you have more than one handset logged on to the base station then you can make internal telephone calls between these handsets. Such internal calls are free of charge since such calls are routed over the base station but not over the telephone network.

### Dialling an internal number

 Int

Press this softkey to open the list of available internal destinations (i.e. other handsets which are logged on to the base station).

 ▼ OK

Select the internal destination you want to call from the list (e.g. **Intern 2** ) and press the «OK» softkey to dial this number.

You may end the internal call by pressing the talk key  again or by placing the handset back in the base station.

---

#### Note

- If you are having an internal conversation then it is not possible to set-up another (second) internal call between other handsets.
- The list of available internal destinations includes only other handsets which are logged on to the base station.
- To find out which handsets are logged on to the base station, press the paging key on the base station. On all logged on handsets you will hear a ring tone and the handset displays read **Paging...**

---

## Callback if busy

Many service operators offer a supplementary network service named “Call Completion Busy Subscriber” (CCBS). When the person whom you are calling is engaged in another conversation (you will hear the busy tone), then you may activate this service. The telephone network will start to monitor the other party’s telephone line. When the other party becomes free, your own telephone starts ringing and when you answer, the network automatically sets-up the connection.

### Activating callback if busy

You are trying to call someone. The called party is already engaged and you hear the busy signal.

 Opt

Open the options menu by pressing the «Options» softkey.

 ▼ OK

Select the menu entry **Callback** and press the «OK» softkey.

Depending on the service provider you may hear a spoken message.



Press the talk key to return to the standby mode and wait for the network to reconnect you.

---

#### Note





- Ask your service provider about the availability and any charges of this service.
  - Make sure that you have programmed the correct network control code for this service (refer to page 45).
  - This service will usually remains active for a limited period of time (e.g. 30 minutes). Ask your service provider for details.
-

## Call anonymously

Your telephone number may be made available to the other party when you make a phone call (ask your service provider about the availability and costs of this CLIP service).

However, you may wish to hide your own telephone number from the person you are calling. In this case, your telephone number will not be displayed on the called party's telephone. Please note that this is a supplementary network service and subject to availability from your service provider.

If you activate this mode then it will only apply to the next telephone call you are making. The mode "call anonymously" is automatically disabled after you have made the call (whether successful or not).

- Your handset is in standby mode.
-  Open the menu by pressing the «Menu» softkey.
-  Select the menu entry **Call anonymously**
-   After pressing the OK key you are requested to enter the phone number of the party you want to call (or use the option softkey **Opt** to access the phonebook or other dialling lists).
-  Press the talk key to dial this number.
- When dialling, the Vtech GEMINI automatically inserts the pre-defined network control code for this service before the telephone number (this is also shown on the display).









---

### Note

- Ask your service provider about the availability and any charges of this service.
  - Make sure that you have programmed the correct network control code for this service (refer to page 45).
- 

## Direct Call

You may switch your Vtech GEMINI into Direct Call mode. In this mode the handset starts dialling a pre-defined telephone number whenever you press any key on the handset. This mode may be helpful for parents with small children. In case when the parents are away, the children can be told that they can reach their parents (or neighbours) simply by pressing any key on the handset. Of course the corresponding telephone number must be programmed in the handset by the parents before.

-  Open the menu by pressing the «Menu» softkey.
-   Select the menu entry **Direct Call** and press the «OK» softkey.
-   Enter the system PIN code and press the «OK» softkey.
-   Select the menu entry **Direct Call On** and press the «OK» softkey.
-   The display shows **Enter number:** and you are requested to enter the destination telephone number. Confirm by pressing the «OK» softkey.
- The handset returns to the standby mode. The display shows **Direct Call** to indicate that direct dialling is activated.
- Whenever you press any key, the handset automatically starts dialling the previously entered telephone number.

---

**Note**

- While Direct Call is activated you can still normally answer any incoming call.
  - De-activate the Direct Call mode by pressing the «Options» softkey **Opt** and selecting the menu entry **Direct Call Off**
  - Key Lock cannot be enabled while in Direct Call mode.
-

# Multiple conversations

Your Vtech GEMINI supports having multiple conversations at the same time. For example, while talking to someone, you can make an inquiry (i.e. put the caller on hold and call someone else).

Some of these „multiple conversation“ features are using supplementary network services offered by your service provider. Ask your service provider about the availability and any charges of such services. Also make sure that the correct network service codes are programmed into your Vtech GEMINI. Refer to page 44 for more information on supplementary network service and their associated codes.

## Call Waiting

Call Waiting is a supplementary network service offered by your service provider. With this service you can be in a telephone conversation and still be informed that someone else is calling you. In this case you will hear the “call waiting“ tone and you may answer this call (while your other conversation is put on hold).

Your Vtech GEMINI supports this network service by offering self-explanatory menu selections for performing several call waiting functions. Remember however that call waiting only works properly if your service provider has made it available to you (e.g. if you have subscribed to this service).











The following call waiting functions are supported by your Vtech GEMINI:

- Enable call waiting
- Disable call waiting
- Accept a waiting call (during another conversation)
- Reject a waiting call (during another conversation)

Please note that you must make sure that the correct control codes for these functions are programmed into your Vtech GEMINI (refer to page 45). Ask your service provider about the correct network service control codes.

## Enable/disable call waiting

You can enable or disable the call waiting features by sending the appropriate network service control code to the network. Only when you enable this call waiting feature, you will hear the call waiting tone when a second call comes in.

- The handset is in standby mode
-  Open the menu by pressing the «Menu» softkey.
  -   Select the menu entry **Settings** and press the «OK» softkey.
  -   Select the menu entry **Network Services** and press the «OK» softkey.
  -   Select the menu entry **Call Waiting** and press the «OK» softkey.
  -  The current call waiting status is shown, e.g. **Switch CW on ✓**.  
Change the status according to your preference.
  -  Confirm with the «OK» softkey. Your Vtech GEMINI starts to send the corresponding network service code over the telephone line. Depending on the service provider you may have to wait for a (spoken) confirmation from the network.
  -  Press the talk key to return to the standby mode.

---

**Note** For fax or modem operation this call waiting function should be switched off, in order to prevent errors in the data transmission.

---

## Accept a waiting call

If you are conducting a conversation, you may accept a second incoming (waiting) call. The procedure is different depending on whether you want to hold or end the first call:





### End the first call

You are conducting a telephone conversation.  
A second external party is calling you. You hear the call waiting signal.



You end your current call by pressing the talk key. The handset starts ringing again indicating the new incoming call.



Press the talk key to answer this incoming call.

OR



### Hold the first call

You are conducting a telephone conversation.  
A second external party is calling you. You hear the call waiting signal.



Open the options menu by pressing the «Options» softkey.



Select the menu entry **Accept CW** and press the «OK» softkey. Your current conversation is put on hold and you are connected to the waiting caller.

---

#### Note

- The network usually allows you a few seconds to accept a waiting call. If you do not respond quickly enough, the calling party will hear a busy tone.
  - If you have put your other conversation “on hold” then you have a choice of different actions to undertake. You may switch between the two conversations (brokering, refer to page 27), you may transfer the call (refer to page 26) or you may enter into a conference call (refer to page 27).
- 

## Reject a waiting call



You are conducting a telephone conversation.  
A second external party is calling you. You hear the call waiting signal



Open the options menu by pressing the «Options» softkey.



Select the menu entry **Reject CW** and press the «OK» softkey. The call waiting signal is switched off, the calling party hears the busy tone and your telephone conversation with your original party continues.

---

#### Note

- Remember to ask your service provider about the availability and any charges of these call waiting services.
  - Make sure that you have programmed the correct control code for these call waiting services (refer to page 45).
- 

## Making an internal inquiry call

When you are conducting an external call, you may want to make an inquiry call to someone else without ending the original conversation.

An internal inquiry call is performed entirely in the base station. This means that internal inquiry calls are not depending on the service offerings of your service provider.



You are conducting an external call and you want to call an internal party without ending the external conversation.



Press this softkey to open the list of available internal destinations (i.e. other handsets which are logged on to the base station).



Select the internal destination you want to call from the list (e.g. **Intern 2** ) and press the «OK» softkey to dial this number.

Conduct your internal inquiry conversation.



You can switch between both parties by pressing the «Brokering» softkey.



You can also enter into a 3-party conference call by pressing the «Conference» softkey.

---

**Note**

- If the other internal party hangs up first, you are again connected to your original external party. If however, you end this inquiry first by pressing the talk key , the external call is automatically connected to the remaining internal party.
  - Only one single internal call can be made at any time.
- 

## Making an external inquiry call

An external inquiry call is performed in the telephone network (supplementary network service). This means that you will have to verify that this service is available from your service provider and that this service is activated with a flash signal. Make sure that the correct flash signal period is programmed in your Vtech GEMINI (refer to page 42).



You are conducting an external call and you want to call another external party without ending the first conversation.



Start the external inquiry call by pressing the R-key (flash key).



If this service is supported by your service provider you will hear the dial tone. Now, enter the external telephone number for your inquiry (or select a number e.g. from the phonebook).

You now have two (external) calls at the same time, one of which is on hold.



You can switch between both parties by pressing the «Brokering» softkey.



You can also enter into a 3-party conference call by pressing the «Conference» softkey.

---

**Note**

- If you end this inquiry by pressing the talk key , the current conversation is ended and your handset starts ringing indicating that you still have another call holding. Press again the talk key to switch back to this conversation.
  - It is not possible to make an external inquiry if you already are in an internal conversation.
- 

## Transferring a call

If you have made an internal inquiry (refer to page 25) and thus you have two calls at the same time (one call on hold), then you may want to connect (transfer) the external call to the internal call on the other handset.



You have two calls, one of which on hold (one external and one internal call).



Simply press the talk key to transfer the call and connect both parties.

## Alternating between calls (brokering)

If you have two calls at the same time (one call on hold), then you may want to switch between both calls without ending either of the calls (brokering).



You have two calls, one of which on hold.



Simply press the «Brokering» softkey to alternate between both calls.



Simply press the talk key to end one of the calls. You are automatically connected to the remaining party.

---

### Note

Remember that brokering between external calls is performed in the telephone network (supplementary network service). This means that you will have to verify that this service is available from your service provider and that the correct control codes are programmed in your Vtech GEMINI (refer to page 45).

---

## Three-party conference calls

If you have two calls at the same time (one call on hold), then you may want to connect all parties in a so-called 3-party conference call.



You have two calls, one of which on hold.



Simply press the «Conference» softkey to enter into a 3-party conference call.

Conduct your conference call now.



Press the «Single» softkey to split up the conference call in individual calls again.



By pressing the talk key in the middle of a conference call, you disconnect yourself from the conversation and both remaining parties are automatically connected (call transfer).

---

### Note

Remember that setting up a conference call between external parties is performed in the telephone network (supplementary network service). This means that you will have to verify that this service is available from your service provider and that the correct control codes are programmed in your Vtech GEMINI (refer to page 45).

---

# Call Forwarding

In case you are busy or away, there are several options for people still to reach you. Although your Vtech GEMINI does not possess an answering machine, your service provider might be offering you such an answering machine through a network mailbox / voicebox. Refer to page 45 for more details.

Another possibility is to forward incoming calls automatically to another telephone number. This is generally known as 'Call Forwarding'. Call Forwarding is not actually performed in your Vtech GEMINI but rather in the telephone network itself. Therefore you must tell the network where you want to forward your calls to and your Vtech GEMINI provides menus to actually do just that.

---

**Note** Call Forwarding is a supplementary network service and thus subject to availability from your service provider. Please ask your service provider about any subscription fees/costs for this service.











---

## Enable/disable Call Forwarding

Your Vtech GEMINI provides menus which make it very easy for you to enable or disable Call Forwarding. You may individually activate or de-activate Call Forwarding for the following situations:

- **CFB – Call Forwarding if Busy**  
Forward all incoming calls only if your telephone line is busy.
- **CFNR – Call Forwarding when No Reply**  
Forward all incoming call when an incoming call is not answered within a certain period of time.
- **CFU – Call Forwarding Unconditional**  
Forward all incoming calls immediately.

Follow the procedure below to enable/disable Call Forwarding:

-  Open the menu by pressing the «Menu» softkey.
-   Select the menu entry **Call Forwarding** and press the «OK» softkey.
-   Select the type of Call Forwarding and press the «OK» softkey:
- CF Unconditional**
- CF if Busy**
- CF when No Reply**
-   Select either the corresponding **On** or **Off** entry to enable or disable this type of Call Forwarding. Press the «OK» softkey to confirm your selection.
-   If you selected the **On** entry you are requested to enter the telephone number to which incoming calls will be forwarded. Press the «OK» softkey to confirm.
- If you selected the **Off** entry you do not have to specify the destination telephone number.
- Your Vtech GEMINI will now connect to the network and send the appropriate network control code(s) to the network. The display shows **Please listen !** to indicate that you may hear a spoken acknowledge notification from the network.
-  Press the talk key to disconnect from the network.

---

**Note**

- Usually CFB and CFNR can be enabled simultaneously to different destination telephone numbers. Please ask your service provider for details.
  - Some service providers offer enhanced features e.g. to request the status of Call Forwarding options. Please ask your service provider for details.
- 

## **Program service codes for Call Forwarding**

Since Call Forwarding is a supplementary network service, special network control codes are required for the Vtech GEMINI to be send to the network to activate/de-activate Call Forwarding.

Refer to page 45 for details on how to set/modify the control codes for the different Call Forwarding options. Make sure the correct codes are entered in your Vtech GEMINI. Please ask your service provider for the correct code values.

# SMS Messages

Sending and receiving of SMS text messages (in conjunction with the CLIP service) is a supplementary network service and thus subject to availability from your service provider. Please ask your service provider about the availability, any charges and how to subscribe to this service.

Your Vtech GEMINI supports SMS text messages with a maximum length of 160 characters. However, not all telephones can receive SMS messages. So if you want to send someone an SMS message, first verify that the person who should receive the message has a telephone with SMS capabilities.

SMS messages are stored in the base station of the Vtech GEMINI. These SMS messages are thus available to all handsets which are logged on to this base station. However, only one handset can use the SMS functionality at the same time.

Your Vtech GEMINI can store up to 15 SMS messages at the same time. In case you reach the maximum storage capacity, you will see a corresponding notification on the display of the handset(s). In this case you must delete one or SMS messages first.

---

**Note**

- Your Vtech GEMINI does only support text formatted SMS messages.
  - Some service providers use an SMS transmission protocol which your Vtech GEMINI is unable to understand. In this case you cannot send nor receive any SMS messages.
  - It is not always possible to send SMS messages to telephone numbers in the network of another service provider (e.g. from fixed networks to GSM networks). Ask your service provider about the current possibilities.
- 

## SMS Service Centres (Gateways)

SMS messages are send and received through so-called SMS service centres (gateways )which you must identify by their respective telephone numbers.

The Vtech GEMINI supports three individual SMS gateways:

- SMS Gateway 1 – for sending and receiving SMS messages
- SMS Gateway 2 – for receiving SMS messages only
- SMS Gateway 3 – for receiving SMS messages only

Many service providers require a specific subscription / initialisation procedure to be completed before you can receive any SMS messages. Often, this is done by sending an SMS with a specific text to a specific number. Ask your service provider about details of such procedures.

---

**Note**

- Make sure that the correct telephone number(s) of the SMS gateway(s) are entered in your Vtech GEMINI otherwise you will not be able to send nor receive SMS messages! Ask your service provider about these gateway numbers.
  - Also make sure that you completed any subscription / initialisation procedures which may be required by your service provider!
- 

## Editing SMS service centre numbers (gateways)

You may edit the telephone numbers of each of the three SMS service centres individually. Please ask your service provider for the correct telephone numbers of the respective gateways.





Open the menu by pressing the «Menu» softkey.



Select the menu entry **Messages** and press the «OK» softkey.

  Select the menu entry **SMS Messages** and press the «OK» softkey.

  Select the menu entry **SMS Gateways** and press the «OK» softkey.

  Select the gateway of your choice and press the «OK» softkey:

**SMS Gateways 1** (sending and receiving SMS messages)

**SMS Gateways 2** (receiving only)

**SMS Gateways 3** (receiving only)





The display shows the current number of this service centre. Edit this number and finish by pressing the «OK» softkey. The display briefly shows **Entry stored !**. The new service centre number is now stored.



..... Press the cancel key for approx. 2 seconds to return to the standby mode.

---

#### Note

- Caution: Sending and receiving SMS messages only works properly when the service centre telephone numbers are entered correctly!
  - Check carefully whether you need to specify the network access code in case your Vtech GEMINI cordless telephone is connected to a PBX system.
- 

## Writing SMS messages

Your Vtech GEMINI supports SMS messages with a maximum length of 160 characters.



Open the menu by pressing the «Menu» softkey.





Select the menu entry **Messages** and press the «OK» softkey.





Select the menu entry **SMS Messages** and press the «OK» softkey.





Select the menu entry **Write new SMS** and press the «OK» softkey.





The display shows **Enter text:**. Enter the text for this new SMS message (refer to page 32 for text editor details) and press the «OK» softkey when finished.

Press the **\*A** key to toggle between uppercase and lowercase characters. All available characters are listed on page **Error! Bookmark not defined.**





The display shows **Enter number:**. Enter the telephone number where you want to send the SMS message to. You can enter the telephone number directly or fetch it from e.g. the phonebook, redial list, etc...

---

#### Note

If you are receiving an incoming call while you are writing an SMS message, then writing of the SMS message is interrupted, your handset starts ringing and you can answer the incoming call. The (incomplete) message is stored in the list of outgoing messages and can be completed and send later.

---

After having entered the SMS text and the destination number you have two options:

- Store the SMS in the list of outgoing SMS messages
- Send the SMS to the specified destination

## Store the SMS message

SMS messages are not automatically stored after sending. So if you want to keep an SMS message make sure that you store it first before sending.

You have entered the SMS text and the destination telephone number.



Select the menu entry **Store SMS** and press the «OK» softkey.

The display shows **Entry stored !**. The SMS is now stored in the list of outgoing SMS messages and can be retrieved again later.



Press the cancel key for approx. 2 seconds to return to the standby mode.

### Note

- Your Vtech GEMINI stores max. 15 SMS messages. If the SMS memory is full, a corresponding warning message is displayed asking you to delete one or more SMS messages first.
- New SMS messages will not be received if the SMS memory is full. So make sure that you delete any SMS messages before all memory space is used up!

## Send the SMS message

You have entered the SMS text and the destination telephone number.



Select the menu entry **Send SMS** and press the «OK» softkey.

The display shows **- Sending SMS -** while your Vtech GEMINI is trying to transfer (send) the SMS message over the network.

If an error occurs while transferring the SMS message, the display will read **SMS not send !**. By pressing the message key  you go directly to the list of outgoing SMS messages where you can try to send the message again.



Press the cancel key for approx. 2 seconds to return to the standby mode.

## Text editor

Your Vtech GEMINI has a text editor with which you can enter and modify texts as well as navigate through the text lines. In the text editor mode, key functions are as follows:

### Toggle between lowercase, uppercase and digits



Press this key to toggle between lowercase, uppercase and digits. The current status is indicate in the bottom line of the display.

### Move the cursor



Move the cursor one character to the left.



(long press)

Move the cursor one line up.



Move the cursor one character to the right.



(long press)

Move the cursor one line down.

### Delete characters



Delete the character left from the cursor.



(long press)

Delete all characters.



Quit the text editor without saving.



## Enter characters



Keys for entering characters. Press the key one or more times to enter the required character. The bottom line of the display briefly lists all available characters for this key.

## Receiving SMS messages

All received SMS messages are stored in the list of incoming SMS messages. New incoming SMS messages are also announced on the handset by displaying the symbol together with the text **New SMS !**. In this case you may press the (blinking) message key which takes you directly to the list of incoming SMS messages.

---

**Note** New SMS messages will not be received if the SMS memory is full. So make sure that you delete any SMS messages before all memory space is used up!

---

## List of incoming SMS messages

Incoming SMS messages are stored together with their reception date and time. Your Vtech GEMINI stores max. 15 SMS messages. If the SMS memory is full, a corresponding warning message is displayed asking you to delete one or more SMS messages first.

Each entry in the list shows the reception date and time, the telephone number of the sender as well as the status (new or read) of the SMS message.

## Reading entries from the list of incoming SMS messages

Open the menu by pressing the «Menu» softkey.

Select the menu entry **Messages** and press the «OK» softkey.

Select the menu entry **SMS Messages** and press the «OK» softkey.

Select the menu entry **Incoming SMS** and press the «OK» softkey.

The first SMS message in the list is displayed, e.g.:

```
New SMS 01/05
031683994412
21.06 15:22
```

The list is sorted by date and time of reception (most recent message first).

Browse through the SMS messages using the navigation keys.

By pressing the «Read» softkey the text contents of the selected SMS message will be displayed.

Use the navigation keys to scroll through multiple lines of text within the SMS message.

Press the cancel key briefly to return to the list of incoming SMS messages.

Press the cancel key for approx. 2 seconds to return to the standby mode.

---

**Note** After having read an SMS message the status of the message is automatically changes from “New” to “Read”.

---

## Options for incoming SMS messages

When reading an incoming SMS message, the following options are available:

Open the SMS options menu by pressing the «Options» softkey.



Select one of the following menu entries and press the «OK» softkey.

- **Answer SMS**  
Select this option if you want to answer this SMS message. You are asked whether you want to copy the text of the original incoming SMS message. Complete the text of your answer and send it off. The destination number is automatically copied from the original sender.
- **Delete SMS**  
Select this option to delete this incoming SMS.
- **Call number**  
If you select this option, your Vtech GEMINI directly dials the telephone number of the sender of this incoming SMS message.
- **Nr.>Phonebook**  
You can copy the telephone number of the sender of this SMS message directly into your phonebook. All you have to do is enter the name to be stored in the phonebook.

---

**Note**

New SMS messages will not be received if the SMS memory is full. So make sure that you delete any SMS messages before all memory space is used up!

---

## List of outgoing SMS messages

The list of outgoing SMS messages contains:

- SMS messages which you have explicitly stored
- SMS messages which could not be send (transmission failure)

SMS message which were send are deleted after successful transmission, unless you have explicitly stored that message. Remember that the SMS storage capacity of your Vtech GEMINI is limited to a total of 15 SMS messages.

## Viewing entries from the list of outgoing SMS messages



Open the menu by pressing the «Menu» softkey.



Select the menu entry **Messages** and press the «OK» softkey.



Select the menu entry **SMS Messages** and press the «OK» softkey.



Select the menu entry **Outgoing SMS** and press the «OK» softkey.

The first SMS message in the list is displayed, e.g.:

**Send SMS 01/12**

**077395578223**

**23.06 09:17**

The list is sorted by date/time of transmission (most recent message first).



Browse through the SMS messages using the navigation keys.



By pressing the «Read» softkey the text contents of the selected SMS message will be displayed.



Use the navigation keys to scroll through multiple lines of text within the SMS message.



Press the cancel key briefly to return to the list of outgoing SMS messages.

## Options for outgoing SMS messages

When reading an outgoing SMS message, the following options are available:

**Opt**

Open the SMS options menu by pressing the «Options» softkey.

**▼ OK**

Select one of the following menu entries and press the «OK» softkey.

- **Send SMS**

Select this option if you want to send this SMS again. You can edit the text as well as the destination number before sending.

- **Edit SMS**

Select this option if you want to edit the text of the SMS. You have the choice of storing or sending the edited SMS message.

- **Delete SMS**

Select this option to delete this outgoing SMS.

---

**Note**

New SMS messages will not be received if the SMS memory is full. So make sure that you delete any SMS messages before all memory space is used up!

---

## Special SMS features

Many service providers offer special features for sending and receiving SMS messages. Here is a selection of frequently offered features:

- Request delivery confirmation
- Send SMS as a FAX
- Send SMS as an E-mail
- Send SMS to a list of recipients (multi-message)
- SMS forwarding

Ask your service provider about the availability of such special features and any corresponding costs/charges.

Your Vtech GEMINI does not provide any dedicated menu entries for these special SMS features.

# Prevent unauthorised use

## Authorised calls

Only handsets which are logged on to the base station are authorised to make and receive telephone calls. Persons who do not have access to your base station nor know your base station's PIN code cannot log on their handset to your base station (refer to page 47 for details of the logon procedure). So even if your neighbours also have an Vtech GEMINI cordless telephone, they cannot make any telephone calls at your expense.

## Tapping your conversation

The handset and base station of your Vtech GEMINI are in connection through a radio channel. The digital transmission between handset and base station is secured and protected from listening in so that it is (practically) impossible for anyone to listen to your conversations.

## PIN code protection

Several functions of your Vtech GEMINI are protected by a secret 4-digit PIN code so that no unauthorised persons can use these features.

Change the initial PIN code as soon as possible to a code which is only known to you (refer to page 41). Never reveal your PIN code to anyone else, but make sure that you remember your PIN code well.

## Key Lock

By activating the key lock (refer to page 11 ) you can prevent that an unintentional key press will execute any function.

# Handset settings

## Setting the ring volume

You can set the volume of the handset ring tone in 5 levels or turn it off completely.

By pressing the **\*Δ** key (approx. 2 seconds) the ring tone is switched on/off. The symbol  indicates that the ring tone is off („do not disturb“).

- Menu** Open the menu by pressing the «Menu» softkey.
- ▼ OK** Select the menu entry **Settings** and press the «OK» softkey.
- ▼ OK** Select the menu entry **HS Settings** and press the «OK» softkey.
- ▼ OK** Select the menu entry **Ring tones** and press the «OK» softkey.
- ▼ OK** Select the menu entry **Ring volume** and press the «OK» softkey.
- ▲ ▼** The current setting is indicated by a tick mark. Select the desired volume level with the navigation keys (OFF, 1 - 5).
  - Off** = no ring tone („do not disturb“)
  - Ring volume 1** ✓ = quietest level (1)
  - Ring volume 5** = loudest level (5)
- OK** Confirm with the «OK» softkey. The new volume level is set.
- C**..... Press the cancel key for approx. 2 seconds to return to the standby mode.

## Setting the ring melody

You can choose between 10 different ring tone melodies.













- Menu** Open the menu by pressing the «Menu» softkey.
- ▼ OK** Select the menu entry **Settings** and press the «OK» softkey.
- ▼ OK** Select the menu entry **HS Settings** and press the «OK» softkey.
- ▼ OK** Select the menu entry **Ring tones** and press the «OK» softkey.
- ▼ OK** Select the menu entry **Ring melody** and press the «OK» softkey.
- ▲ ▼** The current setting is indicated by a tick mark. Select the desired melody with the navigation keys.
- OK** Confirm with the «OK» softkey. The new melody is now set.
- C**..... Press the cancel key for approx. 2 seconds to return to the standby mode.

## Enabling/disabling warning tones

On the Vtech GEMINI you may enable or disable the following audible (warning/acknowledge) signals on the handset:

- Low battery low
- Key click
- Out of range

- Menu** Open the menu by pressing the «Menu» softkey.

-   Select the menu entry **Settings** and press the «OK» softkey.
-   Select the menu entry **HS Settings** and press the «OK» softkey.
-   Select the menu entry **Warning tones** and press the «OK» softkey.
-   Select the warning tone which you want to enable/disable and press the «OK» softkey.
-  The current status is shown, e.g. **Off** . Change the setting according to your preference.
-  Confirm with the «OK» softkey. The selected setting is stored.
-  ..... Press the cancel key for approx. 2 seconds to return to the standby mode.













---

**Note** The key click setting applies also to all acknowledge tones (e.g. when placing the handset back in the base station).

---











## Editing the handset name

You can edit the name of the handset. This helps to identify the handset e.g. if you have more than one handset.

-  Open the menu by pressing the «Menu» softkey.
-   Select the menu entry **Settings** and press the «OK» softkey.
-   Select the menu entry **HS Settings** and press the «OK» softkey.
-   Select the menu entry **HS name** and press the «OK» softkey.
-  You can now edit the name of this handset (max. 15 characters). Press the  key you delete the last character. Switch from uppercase to lowercase characters by pressing .
-  Press the «OK» softkey to confirm the changes.
-  ..... Press the cancel key for approx. 2 seconds to return to the standby mode.





## Select the display language





For the display texts you can choose between several languages.

-  Open the menu by pressing the «Menu» softkey.
-   Select the menu entry **Settings** and press the «OK» softkey.
-   Select the menu entry **HS Settings** and press the «OK» softkey.
-   Select the menu entry **Language** and press the «OK» softkey.
-   Select the language of your choice and press the «OK» softkey.
-  ..... Press the cancel key for approx. 2 seconds to return to the standby mode.

## Select the display contrast













For better display readability you can choose between 8 different display contrast levels.

-  Open the menu by pressing the «Menu» softkey.
-   Select the menu entry **Settings** and press the «OK» softkey.
-   Select the menu entry **HS Settings** and press the «OK» softkey.

-   Select the menu entry **Display contrast** and press the «OK» softkey.
-   Select the contrast level of your choice and press the «OK» softkey.
-  ..... Press the cancel key for approx. 2 seconds to return to the standby mode.









## Set/modify the emergency numbers

Even when the key lock is on, you can still dial emergency numbers. Your Vtech GEMINI supports up to 4 emergency numbers which you can freely assign and/or modify.

-  Open the menu by pressing the «Menu» softkey.
-   Select the menu entry **Settings** and press the «OK» softkey.
-   Select the menu entry **HS Settings** and press the «OK» softkey.
-   Select the menu entry **Emergency No.** and press the «OK» softkey.
-   Select one of the four emergency numbers which you want to assign/modify and press the «OK» softkey.
-   You can now edit the emergency telephone number. Press the  key you delete the last digit. Press the «Store» softkey to confirm the changes.
-  ..... Press the cancel key for approx. 2 seconds to return to the standby mode.

## Resetting the handset to factory settings

With this procedure you can restore the handset settings to factory defaults.

-  Open the menu by pressing the «Menu» softkey.
-   Select the menu entry **Settings** and press the «OK» softkey.
-   Select the menu entry **HS Settings** and press the «OK» softkey.
-   Select the menu entry **Reset HS** and press the «OK» softkey.
-  The display shows entry **Reset HS?** Confirm with the «Yes» softkey. The settings in the handset are reset to factory defaults.
-  ..... Press the cancel key for approx. 2 seconds to return to the standby mode.

The following settings are affected when the handset is reset:

HS Setting	Factory Settings
Language	English
Ring tone volume	High (level 5)
Ring tone melody	Melody 1
Voice volume	Medium (level 3)
Low batt. warning	On
Key click	On
Out of range	Off
Display contrast	Level 4
Log on	Base Station A
Handset name	"INTERN"
Redial list	Empty
Phonebook	Empty

<b>HS Setting</b>	<b>Factory Settings</b>
Emergency #1	110
Emergency #2	112
Emergency #3	117
Emergency #4	911
VIP phonebook	Please note that the VIP phonebook remains unchanged when you reset the handset.

---

**Note** To reset the base station refer page 43.









---



# Base Station settings









## Setting the ring volume

You can set the volume of the base station ring tone in 5 levels or switch it off completely.

-  Open the menu by pressing the «Menu» softkey.
-  Select the menu entry **Settings** and press the «OK» softkey.
-  Select the menu entry **BS Settings** and press the «OK» softkey.
-  Select the menu entry **Ring tones** and press the «OK» softkey.
-  Select the menu entry **Ring volume** and press the «OK» softkey.
-  The current setting is indicated by a tick mark. Select the desired volume level with the navigation keys (OFF, 1 - 5).
  - Off** = no ring tone („do not disturb“)
  - Ring volume 1** ✓ = quietest level (1)
  - Ring volume 5** = loudest level (5)
-  Confirm with the «OK» softkey. The new volume level is set.
-  Press the cancel key for approx. 2 seconds to return to the standby mode.

## Setting the ring melody





You can choose between 10 different ring tone melodies.

-  Open the menu by pressing the «Menu» softkey.
-  Select the menu entry **Settings** and press the «OK» softkey.
-  Select the menu entry **BS Settings** and press the «OK» softkey.
-  Select the menu entry **Ring tones** and press the «OK» softkey.
-  Select the menu entry **Ring melody** and press the «OK» softkey.
-  The current setting is indicated by a tick mark. Select the desired melody with the navigation keys.
-  Confirm with the «OK» softkey. The new melody is now set.
-  Press the cancel key for approx. 2 seconds to return to the standby mode.

## Changing PIN code (Personal Identification Number)

The PIN code is a 4-digit secret number to protect your telephone from unauthorised use.

At the factory, the PIN code is initially set to "0000". It is highly recommended to change this PIN code as soon as possible to your own personal code!

-  Open the menu by pressing the «Menu» softkey.
-  Select the menu entry **Settings** and press the «OK» softkey.
-  Select the menu entry **BS Settings** and press the «OK» softkey.
-  Select the menu entry **Edit PIN** and press the «OK» softkey.
-  Open the menu by pressing the «Menu» softkey.



OK

The display shows **Old PIN:** . Enter the current PIN code (factory setting "0000") and press the «OK» softkey.



OK

The display shows **New PIN:** requesting you to enter a new 4-digit PIN code. Finish by pressing the «OK» softkey.



OK

The display shows **Repeat PIN:** requesting you to enter the new PIN code again. Finish by pressing the «OK» softkey. The display briefly shows **Entry stored !** . The new PIN code is now stored.

**C**.....

Press the cancel key for approx. 2 seconds to return to the standby mode.

**Note**

- Only authorised service staff can reset the PIN code! Thus make sure that you do not forget your PIN code!
- If you enter a wrong PIN code, the display shows **Wrong PIN:** | Press the cancel key (or wait a few seconds) after which you are requested to re-enter the correct code.

## Setting the date and time

To set the date and time on your Vtech GEMINI follow the procedure below:

**Menu**

Open the menu by pressing the «Menu» softkey.



OK

Select the menu entry **Settings** and press the «OK» softkey.



OK

Select the menu entry **Date/time** and press the «OK» softkey.



OK

The display reads: **Enter date:** Enter the current date in the indicated format and press the «OK» softkey.



OK

The display reads: **Enter time:** Enter the current time in the indicated format and press the «OK» softkey.

The new date and time are now stored.

**C**.....

Press the cancel key for approx. 2 seconds to return to the standby mode.

**Note**

The time and date setting is stored in the base station. This means that each change of the time and/or date applies to all other handsets which are logged on to the same base station.

## Selecting the Flash time

A so-called 'flash'-signal is sometimes required to perform special network service functions. Ask your service provider for further details on when to use such a flash signal.

Your Vtech GEMINI has a dedicated key **R** to generate this flash signal. To select the length of the flash signal, follow the procedure below:

**Menu**

Open the menu by pressing the «Menu» softkey.



OK

Select the menu entry **Settings** and press the «OK» softkey.



OK

Select the menu entry **Flash time** and press the «OK» softkey.



Down arrow icon

The current setting is indicated by a tick mark. Select the desired flash time with the navigation keys, e.g. **Flash 100ms**

Select one of the following values (in msec):

- 80, 100, 120, 180, 250, 300 or 600 msec

**OK** Confirm with the «OK» softkey. The new flash time is set.

**C**..... Press the cancel key for approx. 2 seconds to return to the standby mode.

---

**Note** The flash time setting is stored in the base station. This means that each change of the flash time is immediately available to all other handsets which are logged on to the same base station.

---

## Resetting the base station to factory settings

With this procedure you can restore the base station settings to factory settings.

**Menu** Open the menu by pressing the «Menu» softkey.

**▼ OK** Select the menu entry **Settings** and press the «OK» softkey.

**▼ OK** Select the menu entry **BS Settings** and press the «OK» softkey.

**▼ OK** Select the menu entry **Reset BS** and press the «OK» softkey.

**Yes** The display shows entry **Reset HS?**. Confirm with the «Yes» softkey. The settings in the handset are reset to factory defaults.

 **OK** Enter the PIN code and confirm with the «OK» softkey. The settings in the base station are reset to factory defaults.

**C**..... Press the cancel key for approx. 2 seconds to return to the standby mode.

The following settings are affected when the base station is reset:

BS Setting	Factory default
Ring tone volume	High (level 5)
Ring tone melody	Melody 1
Flash time	80 msec
Call Log	Empty
Network access code	none
PIN code	0000 <b>Please note that resetting the base station will not reset the PIN code! So make sure that you remember the PIN code in case you have changed this!</b>
VIP Phonebook	Reset to predefined values.
Network codes	Reset to predefined values.

---

**Note**

- Refer to page 45 for more information on the supplementary network services and the corresponding network codes.
- To reset the handset refer page 38.

---

# Supplementary network services

## Subscribe to network services

Many service providers offer a wide range of supplementary network services. One of the most well-known network services is the "CLIP" service which makes it possible that you can see the telephone number of the person who is calling you.

For many of these network services you need to subscribe to them in order to be able to use them. Ask your service provider about the availability and any additional fees/costs of such services.

## CLIP Service

Your Vtech GEMINI cordless telephone supports the CLIP service. This means that the telephone number of the person who is calling you can be displayed on the handset.

Not all service providers support this CLIP function. Also, calling parties may hide their telephone number (so-called anonymous calls). In such cases the telephone number of the calling party is not displayed on the handset.

## Function codes for network services

Many of the supplementary network services work by sending special function codes (network control codes) from the telephone to the network e.g. **#37\***. Very often these codes include the special characters **#** or **\***. In some cases a so-called „flash“ character may be required. On your Vtech GEMINI you can enter a flash character by pressing the R-key **R**. This flash character is displayed on the handset as **R**.

---

**Note** Please ask your service provider about the exact codes and functionality for each of the available supplementary services !

---

## Using network services through the menu

With your Vtech GEMINI you don't have to remember all these codes. Instead, you may use these supplementary network services through plain softkey or text menu selections!

For example, if you want to set up a conference call between three parties, you don't have to enter the function code which corresponds to this network service. After you have set up a call to each of the other parties, you simply press the «Conference» softkey **Conf**. Your Vtech GEMINI will lookup the corresponding code for this service and send it to the network.







The Vtech GEMINI stores codes for the following network services:

Service description	Code <sup>*)</sup>
Enable call waiting	
Disable call waiting	
Accept a waiting call	
Reject a waiting call	
Brokering (switch between two concurrent calls)	
Set-up a conference call	
Enable Call Forwarding Unconditional (CFU)	
Disable Call Forwarding Unconditional (CFU)	
Enable Call Forwarding No Reply (CFNR)	
Disable Call Forwarding No Reply (CFNR)	
Enable Call Forwarding on Busy (CFB)	
Disable Call Forwarding on Busy (CFB)	
Make an anonymous call	
Initiate callback when party is busy (Call Completion Busy Subscriber)	
Telephone number of the network mailbox/voicebox	

\*) As a reminder for yourself, use this column to write down the appropriate codes according to your service provider's specifications.

## Editing/programming network service codes

Before using any of the supplementary network services please make sure that the correct codes are stored in the Vtech GEMINI. Here is how you can verify and edit these codes:

-  Open the menu by pressing the «Menu» softkey.
-  Select the menu entry **Settings** and press the «OK» softkey.
-  Select the menu entry **Network services** and press the «OK» softkey.
-  Select the menu entry **Edit codes** and press the «OK» softkey.
-  Now select the required network service form which you want to verify or change the control code and press the «OK» softkey.
-  Edit the code according to the service provider specifications and press the «OK» softkey to confirm. The new code is now stored.
-  Press the cancel key for approx. 2 seconds to return to the standby mode.

---

**Note** ● To enter a flash character press the R-key 

---

## Network Mailbox / Voicebox

A special supplementary network service is the so-called 'Network Mailbox' or 'Network Voicebox'. This service acts as an automatic answering machine very similar to the customary mailboxes for GSM telephones.

Please note that this is a supplementary network service and subject to availability from your service provider. Please ask your service provider also about any charges/costs as well as a full description of the service functionality.

Your Vtech GEMINI supports this service by providing a quick dial function assigned to the  key. When you press this key for 2 seconds (long-press) the telephone number of this network mailbox is automatically dialled.







- 
- Note**
- Make sure that the correct telephone number of your network mailbox is programmed in your Vtech GEMINI. Refer to page 45 for details on how to modify this special network control code.
  - In some cases your Vtech GEMINI will not display a text indicating that you have new messages in your network mailbox. This may happen when the communication protocol used by your service provider is not compatible with the protocol supported in the Vtech GEMINI.
  - In order to control this network mailbox (listen to messages, record an announcement, activate/de-activate the mailbox, etc.) you must send appropriate control codes to this mailbox. Ask your service provider for details.
-

# Connecting to a PBX

## Specifying the network access digit

If your Vtech GEMINI cordless telephone is connected to a PBX telephone system, you may have to specify a network access digit to seize an outside telephone line.

If the first digit of a phonenumber matches this network access digit than your Vtech GEMINI will insert a dial pause after this network access digit.

-  Open the menu by pressing the «Menu» softkey.
-  Select the menu entry **Settings** and press the «OK» softkey.
-  Select the menu entry **BS Settings** and press the «OK» softkey.
-  Select the menu entry **PBX code** and press the «OK» softkey.
-   Edit the digit according to the relevant PBX specifications and press the «OK» softkey to confirm. The new digit is now stored.
-  ..... Press the cancel key for approx. 2 seconds to return to the standby mode.

---

### Note

- Please be aware that your Vtech GEMINI does not automatically insert this network access digit before any specified telephone number !
  - For dialling from the Call Log through a PBX refer to page 19.
-

# Multiple handsets

## Registering ( logging-on) the handset

With the Vtech GEMINI you can operate up to 5 handsets on the same base station. This allows you to make internal calls between handsets free of charge. For each handset a procedure must be followed which sets up a radio connection between the base station and the respective handset. This procedure is called „Log on“ and is described hereafter:

- Press the paging key on the base station for approx. 10 seconds until you hear a confirmation tone. The base station is now ready to accept a new handset.

 Open the menu by pressing the «Menu» softkey.

  Select the menu entry **Settings** and press the «OK» softkey.

  Select the menu entry **Log-on HS** and press the «OK» softkey.

 Select **Base station A** to log the handset on to your base station.

If you are using more than one base station, you may select another base station e.g. B, C or D.

 Press the «OK» softkey. The display reads **Searching BS** indicating that the handset is trying to establish a radio connection with the base station.

 If the base station was found, then you are requested to enter the system PIN code of that base station.

 Confirm with the «OK» softkey. The handset is now logged on to this base station. The display will reflect this by showing both the  $\Psi$  and  $\bar{\Pi}$  symbols.

If the log-on procedure was successful, the display will show the name as well as the internal number of the handset e.g. **INTERN 2**. The internal number of the handset is automatically assigned by the base station and cannot be changed.

---

**Note** To make it easier to identify the handset, you may change the name of the handset e.g. to „PETER“ or „MARY“ (refer to page 38).

---

## Register (log-on) to multiple base stations

You can also log on your handset to multiple base stations (max. 4). This is useful e.g. if you have an Vtech GEMINI base station at home and another Vtech GEMINI base station at work. When you log on your handset to both these base stations than you can take this handset with you from home to work and be able to make telephone calls at both locations with just one handset.

In this example you might select base station A for the one at home and base station B for the one at work. In the log-on procedure the handset display indicates the base stations to which you are already logged on by an asterisk: **Base station A \***



## Deregistering the handset

 Open the menu by pressing the «Menu» softkey.

  Select the menu entry **Settings** and press the «OK» softkey.

  Select the menu entry **Log off HS** and press the «OK» softkey.

 Enter the system PIN code of the base station and press the «OK» softkey.

  Select the internal number of the handset to log off, e.g. **INTERN 2** and confirm with the «OK» softkey.

 The display shows **Log off?** Again confirm with the «OK» softkey. The handset with the selected internal number is logged off from the base station.

**C**..... Press the cancel key for approx. 2 seconds to return to the standby mode.

## Switch to another base station

After you have successfully logged your handset on to multiple base stations, you still need to assign the active base station through which you want to make your phone calls. At any given time, only 1 base station can be the active base station for your handset. The handset does not automatically find the strongest radio signal and switches to that base station.

**Menu** Open the menu by pressing the «Menu» softkey.

**▼** **OK** Select the menu entry **Settings** and press the «OK» softkey.

**▼** **OK** Select the menu entry **HS Settings** and press the «OK» softkey.

**▼** **OK** Select the menu entry **Select BS** and press the «OK» softkey.

**OK** Press the «OK» softkey. The currently assigned base station for your handset is displayed, e.g. **Base station A ✓**

**▼** Select the new base station to which you want to switch to.

**OK** Confirm with the «OK» softkey. Your handset is now assigned to the new base station.

**C**..... Press the cancel key for approx. 2 seconds to return to the standby mode.

---

**Note** The display only lists base stations to which the handset was previously logged on.

---

## Language settings for multiple handsets

Be sure to use the same language settings in all handsets. In some cases failing to do so may cause menu texts to be displayed in a different language than set in the respective handset.



# FCC, ACTA and IC Regulations

• In no event shall VTech be liable for any indirect, special, incidental, consequential, or similar damages (including, but not limited to lost profits or revenue, inability to use the product, or other associated equipment, the cost of substitute equipment, and claims by third parties) resulting from the use of this product, some states do not allow the exclusion or limitation of incidental or consequential damages, so the above limitation or exclusion may not apply to you.

## FCC, ACTA and IC Regulations

This equipment complies with Parts 15 of the Federal Communications Commission (FCC) rules for the United States. It also complies with regulations RSS210 and CS-03 of Industry and Science Canada. Operation is subject to the following two conditions: (1) this device may not cause interference, and (2) this device must accept any interference, including interference that may cause undesired operation of the device.

A label is located on the underside of the Base Unit containing either the FCC registration number and Ringer Equivalence Number (REN) or the IC registration number and Load Number. You must, upon request, provide this information to your local telephone company.

This equipment is compatible with inductively coupled hearing aids. Should you experience trouble with this telephone equipment, please contact:

## VTech Communications Inc

CUSTOMER SERVICE at 1-800-595-9511. In Canada, call VTech Telecommunications Canada Ltd. at 1-800-267-7377.

For repair/warranty information. The telephone company may ask you to disconnect this equipment from the line network until the problem has been corrected.

## FCC Part 15

Warning: Changes or modifications to this unit not expressly approved by the party responsible for compliance could void the user's authority to operate the equipment.

The equipment has been tested and found to comply with part 15 of the FCC rules. These limits are designed to provide reasonable protection against harmful interference in a residential installation. This equipment generates, uses and can radiate radio frequency energy and, if not installed and used in accordance with the instructions, may cause harmful interference to radio communications.

However, there is no guarantee that interference will not occur in a particular installation. If this equipment does cause harmful interference to radio or television reception, which can be determined by turning the equipment off and on, the user is encouraged to try and correct the interference by one or more of the following measures:

- Reorient or relocate the receiving antenna.
- Increase the separation between the equipment and receiver.
- Connect the equipment into an outlet or on a circuit different from that to which the receiver is connected.
- Consult the dealer or an experienced radio/TV technician for help.

To ensure safety of users, the FCC has established criteria for the amount of radio frequency energy that can be safely absorbed by a user or bystander according to the intended usage of the product. This product has been tested and found to comply with the FCC criteria. The handset has such a low power that it does not require testing. It may be safely held against the ear of the user. The base unit shall be installed & used such that parts of the user's body other than the hands should be maintained at a comfortable distance of approximately 20 cm or more.

## FCC and ACTA Information

If this equipment was approved for connection to the telephone network prior to July 23, 2001, it complies with Part 68 of the Federal Communications Commission (FCC) rules. If the equipment was approved after that date, it complies with the Part 68 rules and with Technical Requirements for Connection of Equipment to the Telephone Network adopted by the Administrative Council for Terminal Attachments (ACTA). We are required to provide you with the following information.

### 1. Product identifier and REN information

The label on the back or bottom of this equipment contains, among other things, an identifier indicating product approval and the Ringer Equivalence Number (REN). This information must be provided to your local telephone company upon request. For equipment approved prior to July 23, 2001, the product identifier is preceded by the phrase "FCC Reg No." and the REN is listed separately. For equipment approved after that date, the product

identifier is preceded by "US" and a colon (:), and the REN is encoded in the product identifier without a decimal point as the sixth and seventh characters following the colon. For example, the product identifier US:AAAEQ01B123XYZ would indicate an REN of 0.3. The REN is used to determine how many devices you may connect to your telephone line and still have them ring when you are called. In most, but not all areas, the sum of all RENs should be five (5.0) or less. You may want to contact your local telephone company for more information.

## **2. Connection and use with the nationwide telephone network**

The plug and jack used to connect this equipment to the premises wiring and the telephone network must comply with the applicable Part 68 rules and technical requirements adopted by ACTA. A compliant telephone cord and modular plug is provided with this product. It is designed to be connected to a compatible modular jack that is also compliant. An RJ11 jack should normally be used for connecting to a single line and an RJ14 jack for two lines. See Installation Instructions in the user's manual. This equipment may not be used with Coin Telephone Lines or with Party Lines. If you have specially wired alarm dialing equipment connected to your telephone line, ensure the connection of this equipment does not disable your alarm equipment. If you have questions about what will disable alarm equipment, consult your telephone company or a qualified installer.

## **3. Repair instructions**

If this equipment is malfunctioning, it must be unplugged from the modular jack until the problem has been corrected. Repairs to this telephone equipment can only be made by the manufacturer or its authorized agents. For repair procedures, follow the instructions outlined under the Limited Warranty.

## **4. Rights of the telephone company**

If this equipment is causing harm to the telephone network, the telephone company may temporarily discontinue your telephone service. The telephone company is required to notify you before interrupting service. If advance notice is not practical, you will be notified as soon as possible. You will be given the opportunity to correct the problem and the telephone company is required to inform you of your right to file a complaint with the FCC. Your telephone company may make changes in its facilities, equipment, operation, or procedures that could affect the proper functioning of this product. The telephone company is required to notify you if such changes are planned.

## **5. Hearing aid compatibility**

If this product is equipped with a corded or cordless Handset, it is hearing aid compatible.

## **6. Programming/testing of emergency numbers**

If this product has memory dialing locations, you may choose to store police, fire department and emergency medical service telephone numbers in these locations. If you do, please keep three things in mind:

- a We recommend that you also write the telephone number on the directory card, so that you can still dial the emergency number manually if the memory dialing feature doesn't work.
- b This feature is provided only as a convenience, and the manufacturer assumes no responsibility for customer reliance upon the memory feature.
- c Testing the emergency telephone numbers you have stored is not recommended.

However, if you do make a call to an emergency number:

- You must remain on the line and briefly explain the reason for the call before hanging up.
- Programming/testing of emergency numbers should be performed during off-peak hours, such as in the early morning or late evening, when the emergency services tend to be less busy.

## **IC (Industry Canada)**

This telephone is registered for use in Canada.

The term "IC:" before the radio certification number only signifies that Industry Canada technical specifications were met.

### **Notice:**

This equipment meets the applicable Industry Canada Terminal Equipment Technical Specifications. This is confirmed by the registration number. The abbreviation, IC, before the registration number signifies that registration was performed based on a Declaration of Conformity indicating that Industry Canada technical specifications were met. It does not imply that Industry Canada approved the equipment.

### **Notice:**

The Ringer Equivalence Number (REN) for this terminal equipment is 0.1. The REN assigned to each terminal equipment provides an indication of the maximum number of terminals allowed to be connected to a telephone interface. The termination on an interface may consist of any combination of devices subject only to the requirement that the sum of the Ringer Equivalence Numbers of all the devices does not exceed five.

Repairs to certified equipment should be made by an authorized Canadian maintenance facility designated by the supplier. Any repairs or alterations made by the user to this equipment, or equipment malfunctions, may give the telecommunications company cause to request the user to disconnect the equipment. Users should ensure for their own protection that the electrical ground connections of the power utility, telephone lines and internal metallic water

pipe system, if present, are connected together. This precaution may be particularly important in rural areas.

**Caution:**

Users should not attempt to make such connections themselves, but should contact the appropriate electrical inspection authority, or electrician, as appropriate. Your Cordless Phone is designed to operate at the maximum power allowed by the FCC and IC. This means your Handset and Base Unit can communicate only over a certain distance - which will depend on the location of the Base Unit and Handset, weather, and the construction and layout of your home or office.

# The RBRC Seal

## The RBRC Seal



The RBRC® Seal on the nickel-metal-hydride battery indicates that VTech Communications, Inc. is voluntarily participating in an industry program to collect and recycle these batteries at the end of their useful lives, when taken out of service within the United States and Canada.

The RBRC® program provides a convenient alternative to placing used nickelmetal-hydride batteries into the trash or municipal waste, which may be illegal in your area.

VTech's partnership in RBRC® makes it easy for you to drop off the spent battery at local retailers participating in the RBRC® program or at authorized VTech product service centers. Please call **1-800-8-BATTERY** for information on Ni-MH battery recycling and disposal bans/restrictions in your area. VTech's involvement in this program is part of its commitment to protecting our environment and conserving natural resources.

***RBRC® is a registered trademark of Rechargeable Battery Recycling Corporation.***