

**vtech**

## **USB 7100**

---

### **Dual Line Cordless USB Telephone**





## Important

### Before using this telephone, you must:

- Install and charge batteries .....See page 7
- Install software .....See page 9\

### System requirements:

- PC with Windows® 2000 or XP
- 400 MHz processor
- 128 MB RAM
- 15 MB free disk space on your hard drive
- Internet connection (at least 33.6 Kbps)

### Add new handsets to make your phone more versatile

Your telephone can accommodate up to 4 cordless handsets. You can add new handsets (sold separately) at any time (see page 23).



## USB 7100

### Dual Line Cordless USB Telephone



## Table of contents

### Getting Started

Quick reference guide .....	2
Parts checklist .....	3
Before you begin.....	4
Telephone base installation .....	5
Wall mounting .....	6
Battery installation & charging.....	7
Belt clip & optional headset.....	8
Software installation .....	9

### Telephone Operation

Basic operation .....	10
Options while on calls .....	11
Intercom & call transfers .....	12
Handset settings.....	13

### Phonebook

About the phonebook.....	16
New phonebook entries .....	17
Phonebook search .....	18
To dial, change or delete entries ..	19

### Caller ID Logs

How Caller ID works .....	20
To review your call log .....	21

### Appendix

Screen icons & indicator lights ...	22
Adding new handsets.....	23
In case of difficulty .....	24
Technical specifications .....	26
Index.....	27

## Quick reference guide

### Handset

**▼**  
Press to scroll down in menus. While entering names, press to move the cursor to the left.

**▲**  
Press to scroll up in menus. While entering names, press to advance cursor.

**OPTION BUTTON**  
Press to select option displayed above.

**OPTION BUTTON**  
Press to select option displayed above.

**CID**  
Press when phone is not in use to display Caller ID log.

**List/Call**  
Press to make or answer an Internet call.

**Call/Flash**  
Press to make or answer a telephone call. During a call, press to receive an incoming call, if Call Waiting is activated.

**Redial**  
Press to view redial memory.

**Volume**  
Press to adjust ringer or listening volume.

**Off/Clear**  
During a call, press to hang up. While using menus, press to cancel an operation, back up to the previous menu, or exit the menu display.

### Feature menu

> shows highlighted item



Menu

#### Feature Menu

- 1 Sounds .....See page 13
- 2 Handset name ....See page 13
- 3 Auto answer .....See page 14
- 4 Language .....See page 14
- 5 Registration.....See page 14
- 6 Time & date .....See page 14
- 7 Net status .....See page 15
- 8 Country .....See page 15
- \* Key lock.....See page 15

Press **▲** or **▼** to scroll through menu items.

Press **OK** to select or modify a highlighted item.

Press **OFF** to cancel an operation, back up to the previous menu, or exit the menu display.

## Parts checklist

Remember to save your sales receipt and original packaging in case you ever need to ship your telephone for warranty service. Check to make sure the telephone package includes the following:

Telephone base

Telephone handset

Battery compartment cover

Batteries (2)

CD-ROM

AC adapter

Belt clip

USB cable

Long telephone line cord

Short telephone line cord

## Before you begin

### Internet calling

To make and receive Internet calls, you must install software provided on the enclosed CD-ROM (see page 00). You may also be required to establish a Skype™ account to make Internet calls to standard telephones. There may be fees for this service. For more information, please visit [www.skype.com](http://www.skype.com).

### Telephone operating range

This cordless telephone operates with the maximum power allowed by the Federal Communications Commission (FCC). Even so, this handset and base can communicate over only a certain distance — which can vary with the locations of the base and handset, the weather, and the construction of your home or office.

**If you receive a call while you are out of range**, the handset might not ring — or if it does ring, the call might not connect when you press **CALL**. Move closer to the base, then press **CALL** to answer the call.

**If you move out of range during a phone conversation**, you might hear noise or interference. To improve reception, move closer to the base.

**If you move out of range without pressing OFF**, your phone will be left “off the hook.” To hang up properly, walk back toward the telephone base, periodically pressing **OFF** until the call is disconnected.

### About Caller Identification

Caller ID with Call Waiting features let you see who’s calling before you answer the phone, even when you’re on another call. These features require services provided by your local telephone company.

Contact your telephone service provider if:

- You have both Caller ID and Call Waiting, but as separate services (you may need combined service)
- You have only Caller ID service, or only Call Waiting service
- You don’t subscribe to any Caller ID or Call Waiting services.

You can use this phone with regular Caller ID service, and you can use its other features without subscribing to either Caller ID or combined Caller ID with Call Waiting service. There may be fees for these services, and they may not be available in all areas.

Caller ID features will work only if both you and the caller are in areas offering Caller ID service, and if both telephone companies use compatible equipment.

See Caller ID Operation, beginning on page 20, for more details about how these features work.

## Telephone base installation

Install the base as shown below. Choose a location away from electronic equipment, such as television sets or microwave ovens. Avoid excessive heat, cold, dust or moisture.

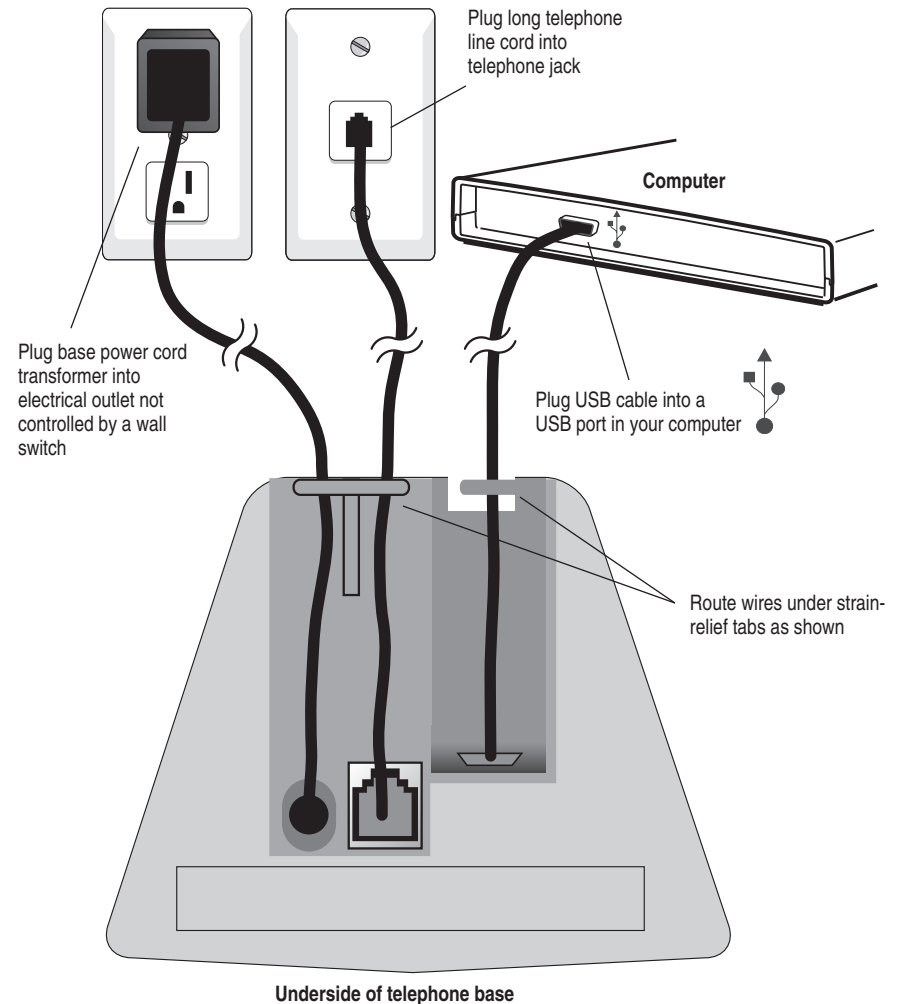

**NOTE:** Use only the power cord supplied with this product. If you need a replacement, call 1-800-222-3111.

## Wall mounting

The telephone base can be installed on any standard wall-phone outlet as shown below. Choose a location away from electronic equipment, such as television sets or microwave ovens. Avoid excessive heat, cold, dust or moisture.

Connect cords as shown on page 5, then press and slide down firmly so base is held securely on outlet mounting pegs

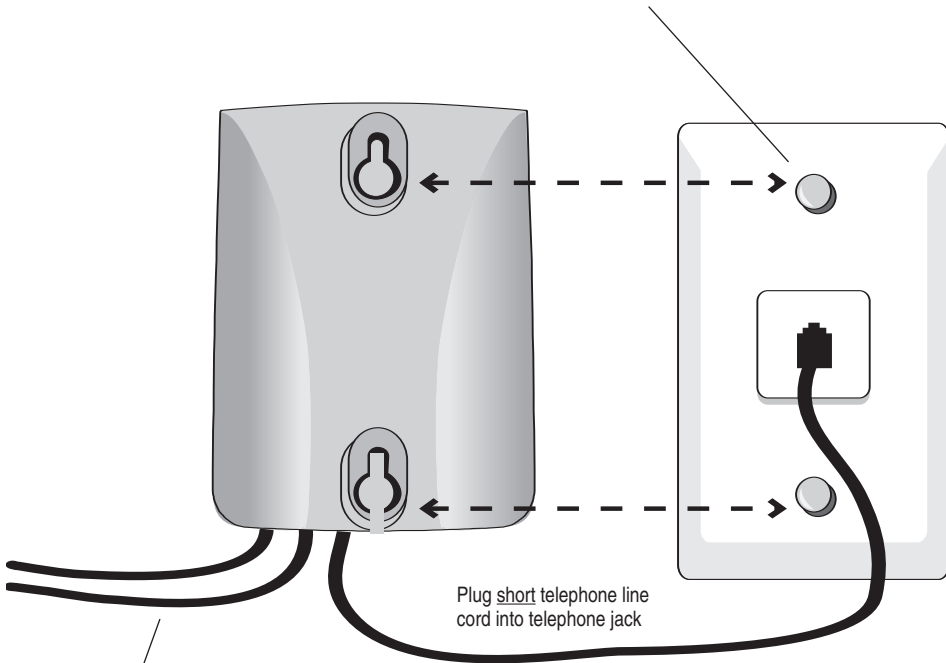

Connect AC adapter and USB cable as shown on page 5

## Battery installation & charging

After installation, place the handset in the base and allow to charge for 12 hours before use. You can keep batteries charged by placing the handset in the base after each use. When batteries are fully depleted, a full recharge takes about 10 hours.

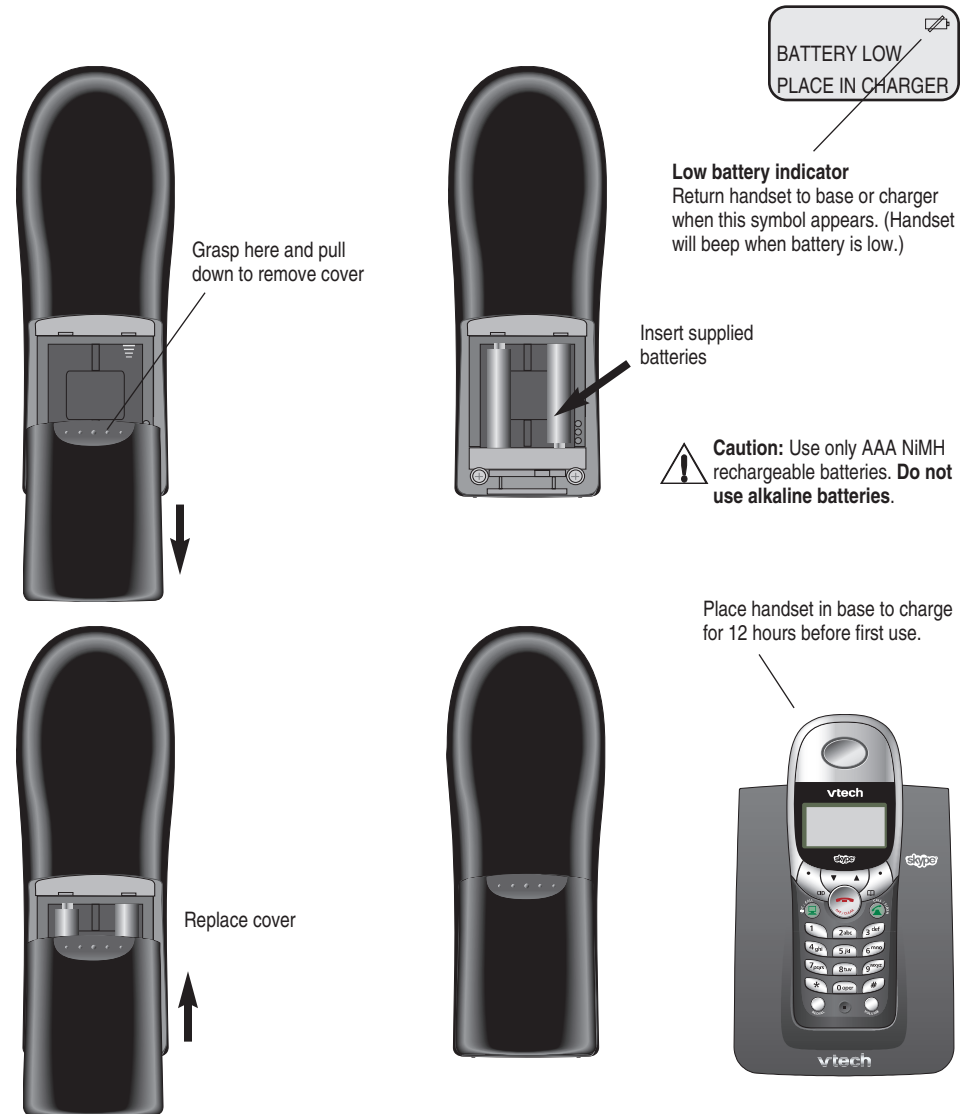

## Belt clip & optional headset

Install belt clip as shown below if desired.

For hands-free telephone conversations, you can use any industry standard 2.5 mm headset (purchased separately).

Insert belt clip tabs into notches on back of handset, then rotate to snap in place

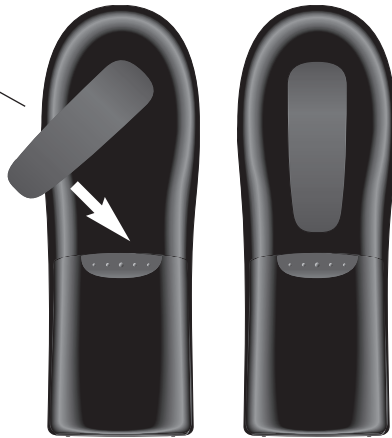

Plug 2.5 mm headset into jack on side of handset (beneath small rubber cap)

## Software installation

To make and receive Internet calls, you must install Vtech™ and Skype™ software provided on the CD-ROM included with your telephone. Before you begin, make sure your system meets the following minimum specifications:

- PC with Windows® 2000 or XP
- 400 MHz processor
- 128 MB RAM
- 15 MB free disk space on your hard drive
- Internet connection (at least 33.6 Kbps)

Insert CD-ROM and wait for opening screen to be displayed

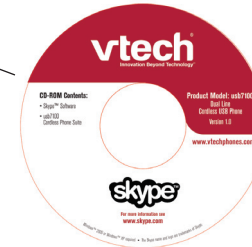

Click to begin installation



## Basic operation

### Making and answering calls

To answer incoming calls, press the **CALL** button that is flashing. If Auto Answer is activated, the call will be answered when you lift the handset from the base (see page 14).

To make calls:

- To make a normal telephone call, press **CALL/FLASH**, then dial a number. Or enter numbers first, then press **CALL/FLASH** to dial.
- To call a Skype™ user, press **LIST/CALL** to see a list of contacts. Press **▲** or **▼** to find the person you want to call, then press **LIST/CALL** to dial.
- To make an Internet call to a standard phone, enter the number, then press **LIST/CALL** to dial.
- If you make a mistake while entering numbers, press **CLEAR** to erase digits one by one, or **press and hold CLEAR** to delete all and begin again.
- To hang up after your call, press **OFF** (or return the handset to the base).

### Last number redial

Press **REDIAL** to display the most recently called number. If the number called is in your phonebook or Internet contact list, the person's name will be displayed. If not, the number called will be displayed.

You can use the **▲ ▼** buttons to view the 10 most recently called numbers.

- Press a **CALL** button to redial any number as it is displayed.
- Press **DELETE** to delete the displayed number from the redial memory.
- Press **STORE** to add the displayed number to your phonebook (see page 17 to edit).

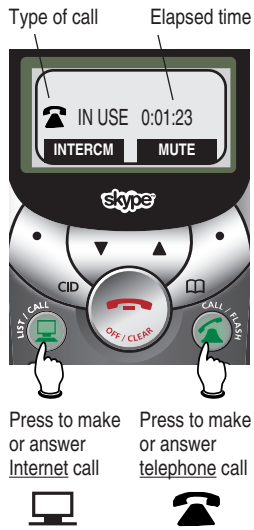

Press to make or answer Internet call



Press to make or answer telephone call

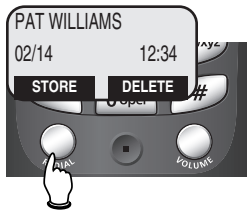

## Options while on calls

### Volume control

Press the **VOLUME** button to adjust listening volume. Each button press raises volume by one level. The next press after maximum volume returns to minimum volume.

### Call waiting

If you have Call Waiting service, you will hear a beep if someone calls while you are already on a call. Press **FLASH** to put your current call on hold and take the new call. You can press **FLASH** at any time to switch back and forth between calls.

**Note:** This feature applies only to standard telephone calls, and cannot be used during Internet calls.

### Mute

Press **MUTE** to silence the microphone during a call. You will be able to hear, but your caller will not be able to hear you until you press **MUTE** again to resume speaking.

### Ring volume and silencing

Press **VOLUME** while the phone is ringing to adjust ringer volume. Press **OFF** while the phone is ringing to silence the ringer.

### Switching between two calls

During a conversation you can press the non-active **CALL** button to put your existing call on hold and make or answer a call on the other line. Press either **CALL** button to switch back and forth between calls.



Press to switch to Internet call

Press to switch to telephone call



## Intercom and call transfers

### Intercom calls

The intercom allows you to communicate with optional expansion handsets without using an outside line.

Press the **INTERCM** button to see a list of active handsets. Press the  $\uparrow$   $\downarrow$  buttons to select the set you want, then press **OK** to page the other handset.

To answer a page, press **INTERCM**. When your intercom call is finished, press **OFF** to end the call.

### Call transfer

During a conversation you can press **INTERCM** to transfer the call to another handset. You can wait to talk to the person at the remote handset before transferring the call, or press **OFF** to transfer the call without talking to the other person.

To answer the transferred call, press **INTERCM** at the remote handset.

If the remote handset does not respond in about 30 seconds, the call will be returned to your handset. If you do not press **INTERCM** to answer within 30 seconds, the external call will be terminated.

### Handset locator

If you lose a handset, press **LOCATE HANDSET** at the base. All registered handsets will ring for 60 seconds to help you locate them. To stop the ringing, press **OFF** at the handset, or press **LOCATE HANDSET** at the base.



Select handset, then press OK to page

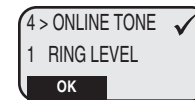
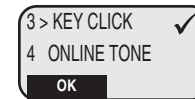
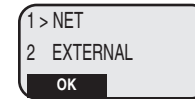
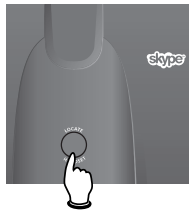

## Handset settings

At the feature menu you can change settings to customize how your handset works.

Press **MENU**, then use the  $\uparrow$   $\downarrow$  buttons to scroll to the feature you want to change. As you scroll through the menu, the top menu item is always highlighted with a **>** character. Press **OK** to select the highlighted item.

Press **OFF** at any time to cancel an operation, back up to the previous menu, or exit the menu display.

### 1 Sounds

**1 Ring level:** Press  $\uparrow$   $\downarrow$  to set ringer volume, then press **OK** to save the current volume level. You can turn the ringer off, or select one of five volume levels.

**2 Ring pattern:** Select type of call (Net or External), press **OK**, then press  $\uparrow$   $\downarrow$  to choose a ringing style. You can choose a different ringing style for each type of call. Press **OK** to save the current style.

**3 Key click:** The handset is factory programmed to click at each keypress. Press **OK** to toggle key clicks on or off (a checkmark appears when on). Press **OFF** to save & exit.

**4 Online tone:** This tone alerts you when someone on your Internet contact list is online. Press **OK** to toggle this tone on or off (a checkmark appears when on). Press **OFF** to save & exit.

### 2 Handset name

At this menu you can customize the name that appears on the handset screen when the phone is idle. The name will also appear in intercom call lists.

See page 17 to learn how to enter letters. If you make a mistake, press **CLEAR** to erase letters. Press **OK** to save the name and exit.



## Handset settings

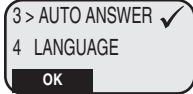

### 3 Auto answer

When on, incoming calls will be answered automatically when you lift the handset from the base. Press **OK** to toggle Auto Answer on or off (a checkmark appears when on). Press **OFF** to save & exit.



### 4 Language

At this menu you can select the language used in all menus and screen displays. Use the **▲▼** buttons to select English, Spanish or French, then press **OK** to save your preference.

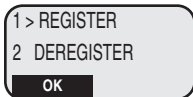

### 5 Registration

Use this feature to add a new handset, or re-register your original handset if necessary. Use the **▲▼** buttons to select Register or Deregister, then press **OK**. See page 00 for further information.



### 6 Time & date

You can choose to set the time and date manually, or have it updated automatically if the USB cable is connected to an operating computer.

Use the **▲▼** buttons to select Automatic or Manual, then press **OK** to save your preference. If you select Manual, you will be prompted to enter the time and day.

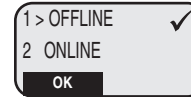

## Handset settings

### 7 Net status

At this menu you can check the current status of your Internet connection, or change how you are identified to the network of other Skype™ users when you are online.

Use the **▲▼** buttons to select one of the status options listed below, then press **OK** to save your preference.

**1 Offline:** You are not currently logged in.

**2 Online:** You are logged in and available for calls.

**3 Away:** Your status is changed to Away when you are logged in, but have not used your computer for a short while.

**4 Not available:** Your status is changed to Not Available when you are logged in, but have not used your computer for an extended period of time.

**5 Do not disturb:** You can activate this status if you are busy and do not want to receive incoming calls.

**6 Invisible:** You can activate this status if you want to make but not receive Internet calls. Other users will see you listed as “Offline.”

### 8 Country

This feature adjusts your telephone to operate properly with the network used in your country. Use the **▲▼** buttons to select USA or Canada, then press **OK**.

### \* Key lock

This feature locks your telephone keypad to prevent accidental button-presses. Press **OK** to lock the keypad. To unlock, press **MENU**, then **☛** in quick succession.

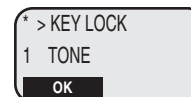

Appears when keypad is locked





160 entries shared by all handsets

# Phonebook

## Shared phonebook directory

The phonebook directory is stored in the base, and is shared by all handsets. Changes made at any handset will be reflected in all handsets.

Only one handset at a time can use the phonebook. If a second handset attempts to use the phonebook, an error message will be displayed.

The phonebook can store up to 160 entries. Each entry can contain a number up to 32 digits, and a name up to 16 letters long. A convenient search feature can help you find and dial numbers quickly (see page 18).

## Timeouts and error messages

If you pause for too long while making an entry the procedure will time out and you will have to begin again.

If all memory locations are in use, an error message will be displayed. You will not be able to store a new number until you delete an existing one.

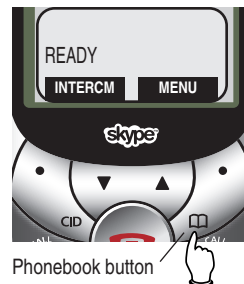

## Phonebook

# New phonebook entries

## To create a new phonebook entry

Press the **PHONEBOOK** button, then press **NEW** to add a new entry. Use the dial pad to enter up to 32 digits, then press **OK**. You will be notified if the number is already in your phonebook.

See page 10 to add a number from your redial list.

- Press **CLEAR** to erase numbers if you make a mistake.
- Press **PAUSE** to enter a 3-second dialing pause.

## To enter a name

Press dial pad buttons once for the first letter, twice for the second, three times for the third. Continue for lower-case letters or numerals.

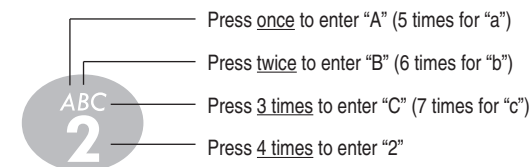

The cursor moves to the right when you press another dial pad button or the **▲** button.

- Press **1** repeatedly to enter a space, ampersand (&), apostrophe ('), comma (,), period (.) or the digit "1".
- Press **▼** to erase letters if you make a mistake.
- Press and hold **CLEAR** to erase all letters.

## Storing the entry

Press **OK** to store your new phonebook entry. To change it later, see page 18.

## Phonebook search

Press the **PHONEBOOK** button, then press **PREVIEW** to display the first entry in the phonebook. You can then use the up/down arrows to browse through the phonebook, or search to find a specific entry. Press **OFF** at any time to exit the directory.

### To browse through the directory

To browse, press **▲** or **▼** to scroll through all entries one by one. Entries will be displayed alphabetically by the first letter in the name.

### To search by name

When any entry is displayed, you can press a dial pad button to display the first name beginning with a letter associated with that key.

Press dial pad buttons once for the first letter, twice for the second, three times for the third, as shown on the previous page.

For example, press **5 (JKL)** once to find Jennifer, twice to find Kevin, or three times to find Linda.

### To call a displayed number

When you find the entry you want, press **CALL** to dial. Or press **EDIT** to modify the entry (see next page).



Phonebook button

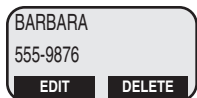
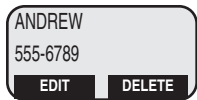
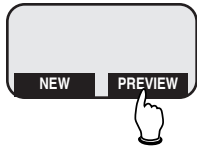

## To dial, change or delete entries

### To dial a number

When any phonebook entry is displayed, press **CALL/FLASH** to dial the displayed number (or press **LIST/CALL** to make an Internet call to this number).

### To delete an entry

When any phonebook entry is displayed, press **DELETE** to delete the displayed entry from the phonebook. Once deleted, an entry cannot be recovered.

### To change a listing

When any phonebook entry is displayed, press **EDIT** to modify the entry. (See page 17 for help in editing the name or number.)

Change the number as needed, then press **OK**. Change the name as needed, then press **OK** to save the entry. The modified entry will be displayed for your review.

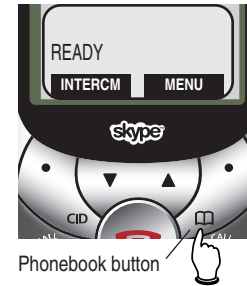

Phonebook button

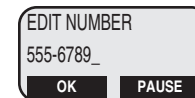
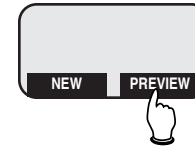



# Caller ID Logs

## How Caller ID works

If you subscribe to Caller ID service provided by your local phone company, information about each caller will be displayed after the first ring.

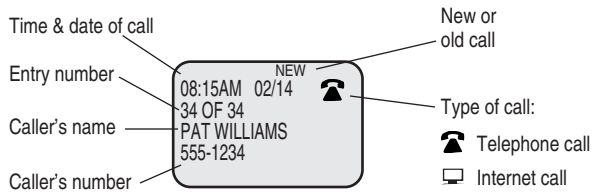

Calls received by all handsets are stored in a shared call log that can store 50 entries. You can review the log to find out who has called, return the call without dialing, or copy the caller's name and number into your phonebook.

When the call log is full, the oldest entry is deleted to make room for new entries.

If you answer a call before the information appears on the screen, it will not be saved in your call log.

## About names

Names of callers will be displayed only if this information is provided by your local telephone company.

If the telephone number of the person calling matches a number in your phonebook, the name that appears on screen will match the name as you entered it into your phonebook.

(Example: If "Christine Smith" calls, her name will appear as "Chris" if this is how you entered it into your phonebook.)

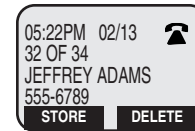
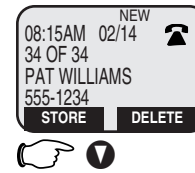

## Caller ID Logs

### To review your call log

#### To review your call log

Press **CID** to review your call log. The most recent call is displayed first. Use the arrow buttons to scroll through the list as shown at left.

#### To return a call

Press a **CALL** button to call the person currently displayed. Press **#** to see a list of dialing options (you can choose to dial with or without the area code or "1" prefix).

#### Other options







- Press **DELETE** to delete the displayed entry from your call log.
- Press and hold **DELETE** to delete all entries from your call log. When asked to confirm, press **YES** to clear your call log of all entries, or **NO** to exit and leave all call log entries intact.
- Press **STORE** to copy this entry into your phonebook. If the name or number are not provided, you will be prompted to enter them.

**Note:** Only calls received on your telephone line can be copied into the phonebook. You cannot copy calls received on your Internet line.

## Screen icons and indicator lights

### Handset screen icons



-  Telephone line
-  Internet line
-  Low battery (place handset in base or charger to recharge)
-  Keypad locked (press **MENU** +  to unlock)
-  Menu item selected
- MUTE** Microphone is muted (press **MUTE** to resume conversation)
- NEW** New calls (press **CID** to review call log)

### Indicator lights



## Adding new handsets



Press  to display Registration



Your telephone can accommodate up to 4 cordless handsets. You can add new handsets (sold separately) at any time.

Before using a new handset, you must first install and charge the batteries (see page 7).

When the batteries are fully charged, follow the steps below to register the handset with the base.

- 1 Press **MENU**, then press  until “Registration” is displayed.
- 2 Press **OK** when “Register” is highlighted.
- 3 After a few seconds, you will be prompted to enter a name for the new handset (see page 17 for help in entering names).
- 4 Press **OK** to save the new handset name. The name you enter will be displayed on screen when the handset is idle, and in intercom paging lists.

## In case of difficulty

If you have difficulty with your phone, please try the suggestions below. For customer service, please visit our Web site at [www.vtechphones.com](http://www.vtechphones.com), or call 1-800-595-9511 (USA) or 1-800-267-7377 (Canada).

### Problems with telephone line

- Make sure batteries are installed and charged correctly (see page 7).
- Make sure the AC adapter is firmly plugged into an outlet not controlled by a wall switch.
- Make sure the telephone line cord is plugged firmly into the base and the modular jack.
- If these suggestions do not work, unplug the base, remove and re-insert the batteries, then follow the steps on page 25 to re-register the handset.

### Problems with Internet line

- Make sure the USB cable is plugged firmly into the base and a working USB port in your computer (see page 5).
- Make sure your computer meets minimum requirements and all software has been properly installed (see page 9). You must establish a Skype™ account before using the Internet line.
- Launch your browser and check to see if you can connect to the Internet. You must establish an Internet connection to make calls.
- Check your Net Status to make sure you are online with the Skype™ network (see page 15).
- Unplug the base, remove and re-insert the batteries, then follow the steps on page 25 to re-register the handset.
- If these suggestions do not work, visit [www.skype.com/help](http://www.skype.com/help) to check for other solutions. Or call VTech Customer Service at the numbers listed above.

### Phone does not ring

- Make sure the ringer is on (see page 13).
- Make sure the telephone line cord and AC adapter are plugged in properly (see page 5).
- Move the handset closer to the base.
- You might have too many extension phones on your telephone line to allow all of them to ring. Try unplugging some of them.

## In case of difficulty

### If you hear noise or interference during a call

- You may be out of range. Move closer to the base.
- Appliances plugged into the same circuit as the base can cause interference. Try moving the appliance or base to another outlet.
- The layout of your home or office might be limiting the operating range. Try moving the base to another location, preferably on an upper floor.
- If the buttons don't work, try placing the handset in the base for at least 15 seconds.
- Disconnect the base from the modular jack and plug in a corded telephone. If calls are still not clear, the problem is probably in your wiring or local service. Call your local telephone service company.

### To re-register the handset

If the error message "Handset Not Registered" is displayed, return the handset to the base. After 60 seconds the handset should beep to indicate that registration is completed.

If registration fails, follow the steps below to re-register your handset:

- 1 Press and hold the **LOCATE HANDSET** button on the base for at least 5 seconds.
- 2 Press menu.
- 3 Press **▼** until "Registration" is displayed, then press **OK**.
- 4 Press **OK** to display "Searching for base," then wait a few seconds. If registration is successful, you will be prompted to enter a handset name.

If you still receive the "Handset Not Registered" message, call VTech Customer Support at the numbers listed on page 24.

## Technical specifications

RF Frequency Band (Handset to Base)	2400 MHz — 2483 MHz
RF Frequency Band (Base to Handset)	2400 MHz — 2483 MHz
Channels	95
Channel Spacing	864 KHz
Output Power	20 dBm
Sensitivity	-96 dBm
Modulation	
	96 — 130 Vrms
Base Unit Voltage (AC Adapter Output)	7 — 13 Vdc @400 mA
Handset Voltage	3.2 — 4.7 Vdc @600 mAh

**PENDING INFORMATION ON  
TECHNICAL SPECIFICATIONS**

## Index

### A

AC adapter, 00  
Alert tones, 00  
Answering calls, 00

### B

Battery charging, 00  
Battery installation, 00  
Belt clip, 00

### C

Call logs, 00  
Caller ID, 00  
    add entries to phone directory, 00  
    delete entries, 00  
    dial entries, 00  
CID, 00  
Conference calls, 00

### D

Delete Call  
Delete redial  
Dialing,  
    manual dialing  
    phonebook

### E

Elapsed time, 00  
Ending calls, 00

### F

Flash (switchhook flash), 00

### H

Hands-free use, 00  
Headphone, 00

### I

Incoming call log, 00  
Incoming calls, answering, 00  
Indicator lights, 00  
Intercom, 00

### L

Last number redial, 00  
Low battery, 00

### M

Making calls, 00  
Menus, 00  
Mute, 00

### N

Names,  
    enter into phonebook, 00  
    search for, 00

### O

Operating range, 00

### P

Paging, 00  
Phonebook

**PAGE REFERENCES PENDING  
APPROVAL OF FINAL DRAFT**

Quick reference guide, 00

### R

Receiving calls, 00  
Recharging, 00  
Redial, 00  
Ring silencing, 00  
Ring tone options, 00

### S

Search for name, 00  
Speakerphone, 00

### T

Technical specifications, 00  
Troubleshooting, 00

### V

Volume controls, 00





[www.vtechphones.com](http://www.vtechphones.com)

Distributed in the U.S.A. by  
VTech Communications, Inc.  
Beaverton, Oregon, 97008  
1-800-595-9511

Distributed in Canada by  
VTech Telecommunications Canada Ltd.  
200-7671 Alderbridge Way, Richmond, B.C. V6X 1Z9  
1-800-267-7377

© 2005 VTech Telecommunications Ltd. All rights reserved.  
VTech brand and logo are trademarks of VTech Telecommunications Ltd.  
Printed in China. Issue 1.1 VTech 03/01/05.