

Important! Before using this telephone, you must read the **Important safety instructions** on page 53 of this manual.

NEED HELP?

This manual has all the feature operations and troubleshooting you need to install and operate your new VTech telephone. Please take the time to review thoroughly to ensure proper installation of this VTech innovative and feature rich product.

You can also visit our website at www.vtechphones.com for support, shopping, and everything new at VTech.

In Canada, please visit www.vtechcanada.com.

VTech toll free 1 (800) 595-9511. In Canada, dial 1 (800) 267-7377

Table of contents

Installation	1	Basic operation	14
Parts checklist	1	Make, answer, and end calls with the handset	14
Handset battery installation	2	Make, answer, and end calls at the base unit	14
Headset installation (optional)	3	Options while on calls	15
Dial mode	4	Speakerphone on the handset.	15
About caller ID information.	4	Hold	15
Telephone settings	5	Mute	15
Handset layout	5	Volume control	15
Handset screen images	6	Ringer silencing	16
Pictures & animations	6	Call waiting	16
Set a wallpaper image	6	Intercom call	17
Set Ringer volume	7	From one handset to all handsets and base unit	17
Set Ringer melody	7	From one handset to a specific handset or base unit	18
Handset sounds	7	Conference call	18
Handset settings	9	Transfer an external call	19
Set time	9	From one handset to the base unit or to another handset.	19
Language	9	Phone book	21
Contrast	10	Store an entry in the phone book	21
Clear voice mail	10	Search the phonebook.	22
Edit handset name	10	Edit a phonebook entry	22
Show handset name	11	Delete a phonebook entry	23
Default settings	11	Delete all phonebook entries	23
Delete registration	11	Advanced operation	24
Handset messages	12	Phonebook	24
Play the message	12	Chart of characters	24
Handset messages	13	Call log	25
Options during playback	13	Review the call log	26
Delete all messages	13		

Table of contents

Dial a call log entry	26	Import contacts into phonebook manager from other PC applications	41
Save an entry to the handset phonebook	27	Exporting contacts to a comma separated text file	42
Delete an entry	27	Deleting phonebook records from the currently loaded phonebook	43
Redial list.	28	Handset icons	44
Dial an entry from the redial list	28	Handset LEDs	44
Save a redial entry to the phonebook on the handset	29	Handset indicators	45
Delete a redial entry	29	Handset icons	45
WiFi setup	30	Add additional headsets	46
Network setup	30	Registration of handset	46
Connection setup on handset	31	Add additional handsets	47
Searching for network	31	Replace a handset.	47
Security key setup	32	De-register a handset	47
PC applications software	34	De-register all handsets	48
Recordable ringer	34	Charge spare battery pack.	49
Record a sound clip by using the audio patch cord .	34	Power guard feature	49
Record a sound clip by using the microphone	35	Installation	49
Special features.	36	Batteries	50
Picture download.	36	Important safety instructions	51
Getting started	36	Troubleshooting.	52
One-time software installation.	36	Operating range.	58
Graphics tab functions.	36	Maintenance	58
Open a graphic file.	37	About cordless telephones	59
Picture download.	37	Warranty	59
To transfer images from the software to the handset	37	FCC, ACTA and IC regulations.	60
Graphic editing.	38	Technical specifications	63
Phonebook tab functions	39	Index	64
Creating an empty phonebook.	39		
Edit a phonebook	40		



- To purchase a new battery pack (part number 29-001155-000-000), visit us on the web at www.vtechphones.com or call VTech Communications, Inc. at 1 (800) 595-9511 in the United States. In Canada, call 1 (800) 267-7377.

Installation

Parts checklist:

Remember to save your sales receipt and original packaging in case it is necessary to ship your telephone for warranty service. Check to make sure the telephone package includes the following:

1. Base unit
2. Handset
3. Battery
4. User's manual
5. VTech PC application CD-ROM
6. Base power adapter

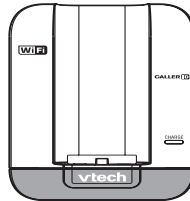

Base unit



Handset

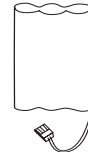

Battery



User's manual

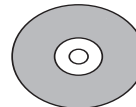

VTech PC application
CD-ROM

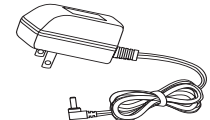

Base power
adapter



- Use only the AC power adapter supplied with this telephone. If you need a replacement, call VTech Communications, Inc. at 1 (800) 595-9511 in the United States. In Canada, call 1 (800) 267-7377.

Installation

Charger installation

Install the charger as shown below. Choose a central location within the home, away from any electronic equipment and appliances such as personal computers, computer routers, television sets, microwave ovens, and refrigerators. Avoid excessive heat, cold, dust or moisture.

Plug the power adapter into an electrical outlet not controlled by a wall switch.

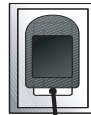

This power unit is intended to be correctly orientated in a vertical or floor mount position.

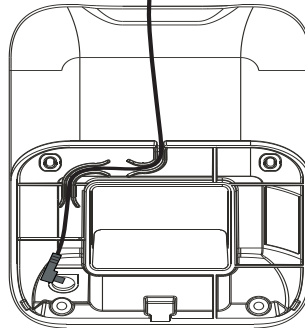



Installation

Handset battery installation

- Press on the tab and remove cover of the battery compartment.
- Place the battery pack and wires in the compartment and plug the battery pack connector into the handset (as shown in diagrams 2a) and 2b).
- Replace the battery compartment cover and slide it up until it clicks into place.
- Put the handset in the telephone base to start charging the new battery for at least 16 hours.

You can keep the battery charged by returning the handset to the telephone base after each use. When the battery power is fully depleted, a full recharge takes about 16 hours.

Use only the supplied VTech rechargeable battery.

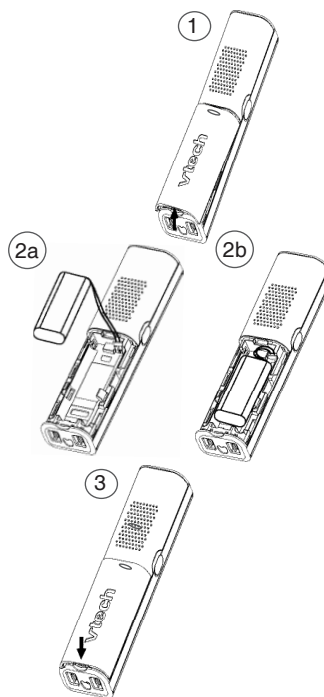

- Use only the VTech battery supplied with this telephone. If you need a new battery, visit us on the web at www.vtechphones.com or call VTech Communications, Inc. at 1 (800) 595-9511 in the United States. In Canada, call 1 (800) 267-7377.
- If the handset is not to be used for a long period of time, remove the battery to prevent possible leakage.



- To purchase a headset, visit us on the web at www.vtechphones.com or call VTech Customer Service at 1 (800) 595-9511. In Canada, call 1 (800) 267-7377.
- Whenever a compatible headset is connected to the cordless handset, the microphone on the handset will be muted. This is done to limit the effect of background noise.

Installation

Headset installation (optional)

For hands-free telephone conversations, use any industry standard 2.5 mm headset (purchased separately). For best result, use a VTech 2.5 mm headset.

Plug the 2.5 mm headset into the jack on the side of the handset (beneath the small rubber cap).



Installation

Dial mode

If you have touch-tone service, your telephone is ready to use as soon as the battery is charged. If you have pulse (rotary) service, the dial mode must be changed. Press /FLASH and there should be a dial tone. If not, refer to the Set dial mode section on page 20.

About caller ID information

The caller ID with call waiting features in this telephone let you see who is calling before answering the call, even when on another call. These features require services provided by your local telephone company.

Contact your telephone service provider if:



- you have both caller ID and call waiting, but as separate services (you may need combined service),
- you have only caller ID service, or only call waiting service, or
- you do not subscribe to any caller ID or call waiting services but wish to try them now.

You can use this telephone with regular caller ID service, and you can use its other features without subscribing to either caller ID or combined caller ID with call waiting service. There may be fees for these services, and these services may not be available in all areas.

The caller ID features will work only if both you and the caller are in areas offering caller ID service, and if both telephone companies use compatible equipment.

Telephone settings

Handset layout

1. Earpiece
2. LCD display
3. Headset jack (2.5 mm)
4. SPEAKERPHONE 
5. NavKeys (four-way)
6. TALK /FLASH
7. Dial pad keys (0-9, *, #)
8. ▼ / ▲ (down/up) softkeys
9. Volume up/down keys
10. MENU/SEL key
11. OFF/CLEAR
12. Microphone

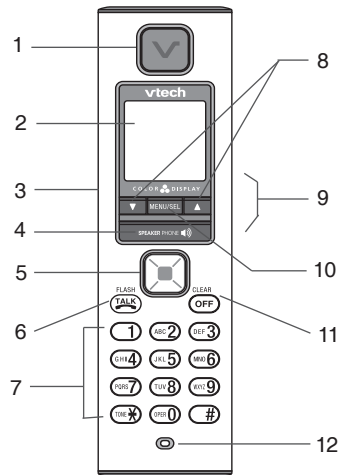





Telephone settings

Handset screen images

Pictures & animations

The handset is preset with 16 pictures and five animations which can be used as the background for your idle screen (wallpaper), or a specific picture or animation can be assigned to a phonebook entry. You can also download your own pictures for use as a wallpaper or with the phonebook entry (see PC **Picture** on page 52).

Set a wallpaper image

- Make sure the handset is in idle mode.
- Press **MENU/SEL** to display the **Phone book** menu.
- Press the **UP** or **DOWN** NavKey  or  until reaching **Pictures**, or **Animations**, and press **MENU/SEL** to select.
- Use the **UP** or **DOWN** NavKey  or  to scroll through the available pictures or animations.
- Press the softkey **SET** to confirm the selection of a desired picture or animation.
- The screen displays **Wallpaper set** and the handset exits to idle screen.
- Press **OFF/CLEAR** at any time to exit the menu without saving any changes.

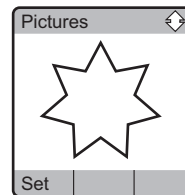
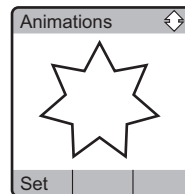







- Ringer Off only affects the incoming external calls whereas minimum ringer still sounds for intercom/paging or calls that ring back after being put on hold.

Telephone settings

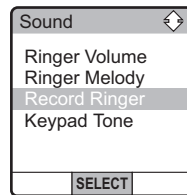

Handset sounds

- When in idle mode, press **MENU/SEL** to display the menu.
- Press the **UP** or **DOWN** NavKey  or  until reaching the **Sounds** menu, and press MENU/SEL to confirm. Use the **UP** or **DOWN** NavKey  or  to scroll through the list of sub-menus (**Ringer Volume**, **Ringer Melody**, **Record Ringer** and **Keypad Tone**). Press **MENU/SEL** to enter the desired sub-menu.
- Press **OFF/CLEAR** at any time to exit the menu.



Set Ringer volume

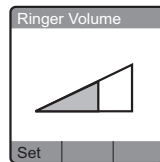

There are options for five levels of ringer volume (including Ringer Off).

- When in the **Ringer Volume** menu, use the **LEFT** or **RIGHT** NavKey  or  to adjust the volume. You can also use the volume control on the right edge of the handset.
- The current level of ringer volume is shaded in green and a sample of the ringer volume will be played.
- Press the softkey **SET** to save your setting.



Set Ringer melody

This feature allows you to assign various ringer melodies for incoming calls. You can choose from eight preset traditional ringers or 13 preset musical ringers or the ringer melody you have recorded.

- When in the **Ringer Melody** menu, use the **UP** or **DOWN** NavKey  or  to scroll through the list of ringer melodies.

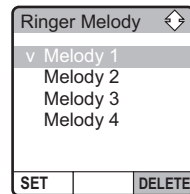

Telephone settings

Handset sounds

- The current selection is highlighted and there will be a sample of each ringer melody when scrolling through the choice.
- Press the softkey **SET** to confirm your setting and the screen displays **Choice saved**.

Keypad Tone

The handset is default to beep at each key press (keypad tone on).

- **When in the Keypad Tone** menu, the current setting (On) is shown with a tick mark on the left. Use the **UP** or **DOWN** NavKey (^) or (V) to toggle between ON or OFF.
- Press the softkey **SET** to confirm your setting.

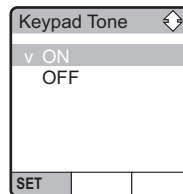





- The time is automatically set and updated with incoming caller ID information if you subscribe this service.





Telephone settings

Handset settings

In the Settings menu, you can change the setting of **Set Time**, **Edit Handset Name**, **Show Handset Name**, **Language**, **Contrast**, **Clear Voice mail**, **Default Settings**, **Delete Registration**, **Product ID**. To enter the **Settings** menu:

- Press **MENU/SEL** in idle mode to display menu.
- Use the **UP** or **DOWN** NavKey  or  to reach the **Settings** menu, and press **MENU/SEL** to choose.



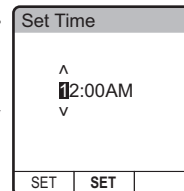

Set time

- When in the **Settings** menu, press **MENU/SEL** to choose Set Time.
- Use the dial pad to enter the time digit by digit. Use the **LEFT** or **RIGHT** NavKey  or  to move to the digit you need to change.
- Use the **UP** or **DOWN** NavKey  or  to choose **AM** or **PM**.
- Press the softkey **SET** to confirm your selection. The screen will display **Choice saved** and there will be a confirmation tone.



Language

At this menu, you can select the language used in all menus and screen displays. Choices are English, French and Spanish.



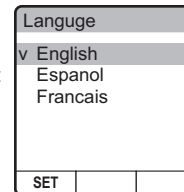

- When in the Settings menu, press the **UP** or **DOWN** NavKey  or  until reaching **Language**. Press **MENU/SEL** to select.
- Use the **UP** or **DOWN** NavKey  or  to choose the language. The current choice is highlighted.
- Press the softkey **SET** to confirm. The screen will display **Choice saved** and there will be a confirmation tone.



Telephone settings

Handset settings

Contrast

- When in the Settings menu, press the **UP** or **DOWN** NavKey  or  until reaching **Contrast**, and press **MENU/SEL** to select.
- Use the **LEFT** or **RIGHT** NavKey  or  to adjust the level of contrast on the LCD screen.
- Press the softkey **SET** to confirm your setting. The screen will display **Choice saved**, and there will be a confirmation tone.

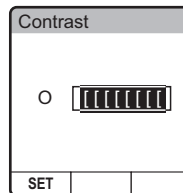





Clear voice mail

This feature allows you to turn off the voice mail indication on the handset.

- When in the **Settings** menu, press the **UP** or **DOWN** NavKey  or  until reaching **Clear Voice Mail**, and press **MENU/SEL** to select.
- The screen displays **Clear Voice Mail Indication Are you sure?**
- Press the softkey **YES** or **NO** to confirm.

Edit handset name

- When in the **Settings** menu, press the **UP** or **DOWN** NavKey  or  until reaching **Edit Handset Name**, and press **MENU/SEL** to select.
- Use the dial pad (see page 33) to enter the handset name. Use the **LEFT** or **RIGHT** NavKey  or  to move the cursor.
- Press the softkey **ERASE** to backspace and press the softkey **SET** to confirm the changes. The screen will display **Choice saved** and there will be a confirmation tone.







- Record and settings in Phonebook, Call log, redial list and time will not be affected by restoring default setting.

Telephone settings



Handset settings

Show handset name

- When in the **Settings** menu, press the **UP** or **DOWN** NavKey  or  until reaching **Show Handset Name**. Press **MENU/SEL** to select.
- The current selection is marked with a tick. Use the **UP** or **DOWN** NavKey  or  to toggle between **On** or **Off**.
- Press the softkey **SET** to save your setting.

Default settings

In this menu, you can reset the setting changed including setting in the Settings menu, Sounds, Picture, and Animation menu.

- When in the Settings menu, press the **UP** or **DOWN** NavKey  or  until reaching **Default Settings**. Press **MENU/SEL** to select.
- The screen displays **Restore Default Settings Are you sure?**
- Press the softkey **YES** or **NO** to confirm.

Delete registration

In this menu, you can de-register the handset and you will need to register it again to be able to use it.

- When in the **Settings** menu, press the **UP** or **DOWN** NavKey  or  until reaching **Delete Registration**. Press **MENU/SEL** to select.
- The screen displays **Delete Handset Registration Are you sure?**
- Press the softkey **YES** or **NO** to confirm.



Telephone settings

Handset messages

This feature allows you to access messages on the answering system by using the handset.

When there are new messages on the answering system, New Message will be displayed on the handset screen, and the answering system icon will flash on the handset screen in idle mode.

- The day and time the message was recorded will be announced before playback.
- If the handset cannot access the answering system, **Answering system is not available** will be displayed on the screen.
- The screen on the handset will show the day and time the memo and incoming messages are recorded, the length of the message, and a diagram of the NavKey illustrating how to repeat or skip a message.

Play the message

From screensaver mode (if there are new messages):

- Press **STOP/CLEAR**, and the screen will display **New Message**. Press **MENU/SEL** and the screen displays the number of new and old messages.
- Press the softkey **PLAY** to play the message.

From idle mode (if there are new messages):

- Press the softkey **MESSAGE** to access the message menu. The screen displays the number of new and old messages.
- Press the softkey **PLAY** to play the message (s).

From the main menu:

- Press **MENU/SEL** when in idle mode.

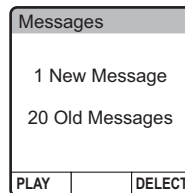





Telephone settings

Handset messages

- Press the **DOWN** NavKey  twice to reach **Messages**. Press **MENU/SEL** to select.
- The screen displays number of new and old messages. Press the softkey **PLAY** to play the message.

Options during playback

- Press  /**VOLUME** to adjust the speaker volume.
- Press the softkey **STOP** to stop the message currently playing.
- Press the **LEFT** NavKey  to skip to the next message.
- Press the **LEFT** NavKey  to repeat the currently playing message.
- Press the **LEFT** NavKey  twice (quickly) to go back to the previous message.
- Press the softkey **DELETE** to delete the message currently playing.

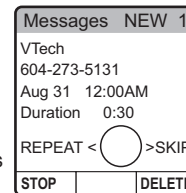









Delete all messages





- Press **MENU/SEL** when in idle mode.
- Press the **DOWN** NavKey  twice to reach **Messages**. Press **MENU/SEL** to select.
- The screen displays the number of new and old messages. Press the softkey **DELETE** to delete all messages.
- The screen displays **Delete all Messages Are you sure?** Press the softkey **YES** or **NO** to confirm.

Basic operation

Make, answer, and end calls with the handset

- Press /FLASH or , then dial the number.
-OR-
- Dial the number (use the **LEFT NavKey**  to backspace; use the softkey **PAUSE** to insert a pause), then press /FLASH or,  if you want to use speakerphone.
- To answer a call, press /FLASH or,  if you want to use speakerphone.
- To end a call, press /CLEAR, or put the handset back to the base unit.

Make, answer, and end calls at the base unit

- Press /SPEAKER, then dial the number.
-OR-
- Dial the number (press **CLEAR** to backspace; use the softkey **PAUSE** to insert a pause), then press /SPEAKER to connect.
- To answer a call, press /SPEAKER.
- To end a call, press /SPEAKER.



- The handset will display **Call on Hold** when a call is placed on hold. A  will flash and the base unit will ring as a reminder that a call is on hold.
- If a call remains on hold for one minute, the handset and the base unit will ring to remind you the call is on hold. The screen will display **Call on Hold Ringback!** You have 30 seconds to return to the call before it is disconnected.

Basic operation



Options while on calls

There are a few options while on a call, including speakerphone on the handset, hold, mute, volume control, ringer silencing and call waiting on both the handset and the base unit.

Speakerphone on the handset

- During a call, press  to toggle between speakerphone and normal handset use.

Hold

- During a call, press the softkey **HOLD** on the handset or at the base unit to put a call on hold.
- To return to the call, press  /**FLASH** or  at the handset, or  /**SPEAKER** at the base unit.

Mute

Using the mute function allows you to mute the microphone and the other party cannot hear you, while you can still hear the other party.

- During a call, press the softkey **MUTE** on the handset or at the base unit to mute the microphone.
- Press the softkey **UNMUTE** to return to normal conversation.

Volume control

- During a call, use the volume control on the right side of the handset, or the volume control on the base unit, to adjust the listening volume.
- Press **+** or **-** on the volume control key to adjust the volume to a comfortable level.

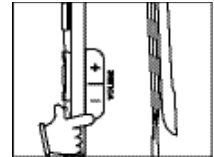

Basic operation

Ringer silencing

This feature allows you to silence the ringer temporarily when the telephone is ringing.

- Press the softkey **SILENCING** on the handset or the softkey **QUIET** on the base unit to temporarily silence the ringer.

Call waiting

If you subscribe to the call waiting service, press the softkey **FLASH** on the handset or at the base unit to answer the new incoming call.









- You must have at least one additional handset to intercom call from one handset to another handset.

Basic operation

Intercom call

The intercom feature allows a conversation between the handset and the base unit, or between handsets if additional handsets are registered for use with the system.

From one handset to all handsets and base unit:



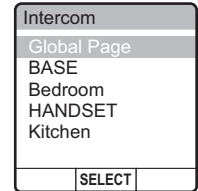



- Press **MENU/SEL** to display menu when in idle mode.
- Press the **DOWN** NavKey  three times to reach **Intercom** and press **MENU/SEL** to enter the menu.
- Press **MENU/SEL** and select **Global Page**.
- The base unit and all handsets will ring, and the screen displays **Global Page from Handset 1** (if the global page is from handset 1).
- To answer the page on any handset, press /**FLASH**,  or any  keys on the dialing pad. To answer the page at the base unit, press **INTERCOM** or /**SPEAKERPHONE**.
- To end an intercom call on any handsets, press /**CLEAR**. To end it at the base unit, press **INTERCOM** or /**SPEAKERPHONE** at the base unit.





Basic operation

Intercom call

From one handset to a specific handset or base unit

- Press **MENU/SEL** to display menu when in idle mode.
- Press the **DOWN** NavKey  three times to reach **Intercom** and press **MENU/SEL** to enter the menu.
- Use the **UP** or **DOWN** NavKey  or  to scroll to the destination handset or base unit, and press **MENU/SEL** to confirm.
- The destination handset or base unit will ring, and the screen displays **INTERCOM from Handset 1** (if the page is from handset 1).
- To answer the page on any handset, press /FLASH,  or any keys on the dialing pad. To answer the page at the base unit, press **INTERCOM** or /SPEAKERPHONE.

Conference call

This feature allows you to have conference calls with up to three registered handsets and the base unit. To enter a conference call, simply access the line with up to three handsets and the base unit by pressing /FLASH or  on the handset or at the base unit. The icon  will be displayed.



- You must have at least one additional handset to intercom a call from one handset to another handset.







Basic operation

Intercom call

Transfer an external call

This telephone allows you to transfer an external call from the base unit to any handset, from handset to handset, or from handset to the base unit.





From one handset to the base unit or to another handset

- During a call, press **HOLD** to put the call on hold on the originating handset.
- Press **MENU/SEL**, then use the **DOWN** NavKey ▼ to scroll to **Intercom**, and press **MENU/SEL** to confirm.
- Use the **UP** or **DOWN** NavKey ▲ or ▼ to scroll to the base unit, or destination handset. Press **MENU/SEL** to confirm.
- The destination handset or the base unit will ring, press  **FLASH** or  on the destination handset to answer, or press **INTERCOM** or  **/SPEAKERPHONE** to answer at the base unit.
- Press  **/CLEAR** on the originating handset to transfer the call.
- Press  **/FLASH** on the destination handset or press  **/SPEAKERPHONE** at the base unit to pick up the call on hold.

Basic operation

Intercom call



Answer an incoming call during an intercom call

- During an intercom call, there will be an alert tone which signals an incoming call.
- To terminate the intercom call without answering the incoming call, press  /**CLEAR** on the handset, or press **INTERCOM** at the base unit. The base unit will ring and the incoming call can be answered normally.
- To connect the incoming call with the intercom call, press  /**FLASH** or  on the handset, or press  **SPEAKERPHONE** at the base unit to answer the incoming call.

Telephone operation

Phone book

The phonebook on the handset can store up to 100 entries, along with a distinctive ringer and picture for each entry. The phonebook each consisting of entry up to 32 digits and 16 characters, .



- The phonebook menu can be assessed in idle mode by pressing the **UP** or **DOWN** NavKey  or , or pressing **MENU/SEL** twice.
- **Phone book is empty** is displayed on the screen when there is no entry in the phone book.
- Press **OFF** to exit the menu without saving any changes.

Store an entry in the phone book

- When in the **Phone book** menu, press the softkey **NEW** to create a new entry.
- The screen displays **Enter Name**, use the dial pad keys (0-9, *, #) and refer to the **Chart of characters** on page 33 for the instructions to enter the name. Press the softkey **DONE** to save the name and go to the **Enter Number** screen.
- Press the softkey **SAVE** if you do not wish to assign any distinctive ringer and picture to this entry (if you wish to assign distinctive ringer and picture, refer to **Customize entries** on page 34).



Customize entries

This feature allows you to assign a distinctive ringer and picture/animation to a specific entry. The distinctive ringer and picture/animation will alert you when this person calls. You can customize the entries before saving it, either in the phonebook, call log list, or redial list.

- When in the screen display as shown on the top right, use the **UP** or **DOWN** NavKey  or  to highlight **Ringer: <Default>**, or **Picture: <Default>**.

Telephone operation

Intercom call

- Use the **LEFT** or **RIGHT** NavKey  or  to choose the desired ringer, or picture/animation.
- When scrolling through the selection, a sample of the ringer will be played, and a sample of the picture/animation will be displayed.
- Press the softkey **SAVE** when done. The screen displays **Entry has been saved** and there will be a confirmation tone.





Search the phonebook

Entries are sorted alphabetically, and names beginning with numbers are presented first. An alphabetical search can be done after entering the phonebook.



For example, press 5 (JKL) once to find Jenny, twice to find Kristen, or three times to find Linda.

- When in the **Phonebook** menu, press the softkey **FIND**.
- Use the dial pad to enter the alphabet and press the softkey **SET** to confirm.

Dial a phonebook entry

- When in the **Phonebook** menu, use the **UP** or **DOWN** NavKey  or  to scroll to the desired entry, or use the softkey **FIND** to search for it.
- Press /FLASH or press  to dial the entry.

Edit a phonebook entry





- When in the **Phonebook** menu, use the **UP** or **DOWN** NavKey  or  to scroll to the entry to be edited, or use the softkey **FIND** to search the entry. Press **MENU/SEL** to select the entry.





- There are eight traditional ring tones and 17 musical ringers. For **Recordable ringers**, see page 50.
- There are 29 preset pictures and animations to choose from. For **Picture download**, see page 52.

Telephone operation



Intercom call

- Press the softkey **EDIT** and use the **UP** or **DOWN** NavKey  or  to highlight the item (name, number, distinctive ringer, distinctive picture/animation) to be edited.
- Use the dial pad and the softkey **BACK** to edit the name and number, and use the **LEFT** or **RIGHT** NavKey  or  to choose the desired ringer and picture/animation.
- Press the softkey **SAVE** to save the changes. The screen displays **Entry has been saved** and there will be a confirmation tone.

Delete a phonebook entry

- When in the **Phonebook** menu, use the **UP** or **DOWN** NavKey  or  to scroll to the entry to be deleted, or use the softkey **FIND** to search for it. Press **MENU/SEL** to select the entry.
- Press the softkey **DELETE**, and the screen displays Delete Options menu. Press **MENU/SEL** to select Delete Entry and there will be a confirmation tone.

Delete all phonebook entries

- When in the **Phonebook** menu, use the **UP** or **DOWN** NavKey  or  to scroll to the entry to be deleted, or use the softkey **FIND** to search for it. Press **MENU/SEL** to select the entry.
- Press the softkey **DELETE**, and the screen displays Delete Options menu. Press **DOWN** NavKey  once and press **MENU/SEL** to select Delete All Entries.
- The screen displays Delete entire Directory Are you sure? Press the softkey **YES** or **NO** to confirm, and there will be a confirmation tone.



Advanced operation

Phonebook

Chart of characters

Use the dial pad and the chart below to enter a name (up to 16 characters). Each press of a particular key causes characters to be displayed in the following order:

Number Key	Characters by number of key presses								
	1	2	3	4	5	6	7	8	9
1	&	'	,	.	1	Space			
2	A	B	C	a	b	c	2		
3	D	E	F	d	e	f	3		
4	G	H	I	g	h	i	4		
5	J	K	L	j	k	l	5		
6	M	N	O	m	n	o	6		
7	P	Q	R	S	p	q	r	s	7
8	T	U	V	t	u	v	8		
9	W	X	Y	Z	w	x	y	z	9
0	0								
*	*								
#	#								

- When editing characters, press the softkey **BACK** to backspace. Press the **LEFT** or **RIGHT** NavKey  or  to move the cursor. Press the **RIGHT** NavKey  again to add a space.
- Press and hold the **#** key to insert a dialing pause.



- Due to regional service difference, the CID information may not be available for every incoming call. In addition, the caller may intentionally block their name and/or telephone number.

Telephone operation

Call log

If you subscribe to the caller ID service, information about each caller will be displayed after the first or second ring.

- The handset call log can store up to 100 entries, and the call log in the base unit can store up to 50 entries.
- You can review, redial, and copy the entry into your phonebook.
- Entries are displayed in reverse chronological order, i.e. from the latest entry to the earliest entry.
- When the call log is full, the earliest entry is deleted to make room for new incoming call information.
- **New Call** will be displayed on both the handset and the base unit if there are new call log entries, i.e. missed call (including missed call waiting record) and unreviewed calls.
- You can also listen to messages (if the callers left messages) when reviewing the call log.





The call log can be accessed on the handset by pressing the softkey **CALL LOG**, or pressing **MENU/SEL** and **DOWN** NavKey **⏴** once, and then press **MENU/SEL** again. You can also access the call log at the base unit by:

- pressing the softkey **MENU** to enter the menu, then
- pressing the softkey **SELECT** to select **CALL LOG**.

Telephone operation









Call log

Review the call log









- When in the call log, use the **UP** or **DOWN** NavKey  or  to scroll through the call log on the handset. Use the softkey  or  to scroll through the call log on the base unit.
- The name, number, date and time of receiving call, and message (if the caller left a message) are displayed on the screen.
- Press the **RIGHT** NavKey  to play the message on the handset. Press the softkey **SELECT** on the base unit twice to play the message at the base unit.

Dial a call log entry

On the handset:

- When in the call log, use the **UP** or **DOWN** NavKey  or  to scroll to the desired entry. Press /FLASH or  to dial the number.
- Press **#** or **MENU/SEL** to display the possible dialing options.
- Use the **UP** or **DOWN** NavKey  or  to scroll through the choices, and press the softkey **DIAL** or /FLASH or  to dial the number.

At the base unit:

- When in the call log, use the softkey  or  to scroll to the desired entry. Press /SPEAKERPHONE to dial the entry.
- To see the dial options, press the softkey **SELECT**, use the softkey  or  to scroll to **DIAL OPTIONS** and press **SELECT**.
- Use the softkey  or  to scroll through the choice, and press the softkey **DIAL** or /SPEAKERPHONE to dial.



- While reviewing the call log, press **#** repeatedly to display the alternate dialing options. The available options are: (1 + area code + number, area code + number, 1 + number, number only).





- The time is automatically set and updated with incoming caller ID information if you subscribe to this service.
- If you have more than one handset, setting the date and time on one handset will automatically update all other handsets.

Advanced operation



Call log

Save an entry to the handset phonebook





- When in the call log, use the **UP** or **DOWN** NavKey  or  to scroll through the call log and highlight the entry to be saved. Press the softkey **SAVE** to save the entry to the phonebook.
- Use the dial pad to enter the name, and press the softkey **SET** when done.
- If you do not wish to customize the entry, press the softkey **SAVE** to confirm. The screen displays **Entry has been saved** and there will be a confirmation tone.
- If you wish to customize the entry, see the section **Customize entries** on page 34.

Delete an entry

From the handset:

- When in the call log, press the **UP** or **DOWN** NavKey  or  to scroll to the entry to be deleted. Press the softkey **DELETE** to confirm, and there will be a confirmation tone.

From the base unit:

- When in the call log, use the softkey  or  to scroll to the entry to be deleted. Press the softkey **SELECT** to select.
- Use the softkey  or  to scroll to **DELETE CALL LOG**, and press the softkey **SELECT** to confirm.
- Press the softkey **THIS** if only deleting this entry. Press the softkey **ALL** if deleting all entries. Press the softkey **YES** to confirm, and there will be a confirmation tone.

Advanced operation

Redial list





The handset and the base unit can store the ten most recently dialed numbers in the redial list. You can review, redial, or save the number into the phonebook.

- When there are already ten entries on the redial list, the earliest entry is deleted to make room for the new entry.
- Entries are displayed in reverse chronological order, i.e. from the latest entry to the earliest entry.
- **Redial list is empty** is displayed on screen if there is no dialed number on the list.



The redial list can be accessed on the handset and the base unit by pressing the softkey **REDIAL** in idle mode.

Dial an entry from the redial list

From the handset:

- When in the redial list, use the **UP** or **DOWN** NavKey  or  to scroll to the desired number.
- Press /**FLASH** or  to dial.
- To add a pause to the number, press **MENU/SEL** to select the number, and press the softkey **PAUSE** before dialing.



From the base unit:

- When in the redial list, use the softkey  or  to scroll to the desired number.
- Press /**SPEAKERPHONE** to dial.

Advanced operation



Redial list

Save a redial entry to the phonebook on the handset



- When in the redial list, press the **UP** or **DOWN** NavKey  or  to scroll to the number to be saved.
- Press the softkey **SAVE**.
- Use the dial pad to enter the name for the entry. Press the softkey **SET** when finished.
- If you do not wish to assign a distinctive ringer and picture/animation to the entry, press the softkey **SAVE** to confirm. The screen displays **Entry has been saved** and there will be a confirmation tone.
- If you wish to assign a distinctive ringer and picture/animation to the entry, see the section **Customize entries** on page 34.

Delete a redial entry

From the handset:

- When in the redial list, use the **UP** or **DOWN** NavKey  or  to scroll to the number to be deleted.
- Press the softkey **DELETE**, and there will be a confirmation tone.

From the base unit:

- When in the redial list, use the softkey  or  to scroll to the number to be deleted. Press the softkey **SELECT** to select.
- Press the softkey **DELETE** to confirm, and there will be a confirmation tone.

WiFi setup

In order to enable the WiFi feature to function, you need to setup the network, computer and handset as told in the following section.

Network setup

Before the handset can access PC application, the correct home network and computer setups have to be completed.

To connect the handset to the PC application, the computer network will need to have the configuration as shown below:

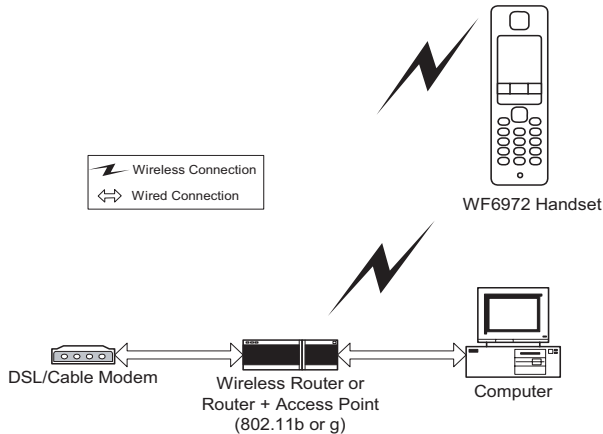

In the setup, a wireless router or a combination of router and access point is required. Also, a DHCP (Dynamic Host Configuration Protocol) server is to be running either on the router or PC.



- For the router or access point, it has to be 801.11 b or g compatible.



- The most common network IP addresses look like 192.168.X.X. and X.X.X.X. will depend on how the network has been set up.
- The computer can be connected to the network through a wired or wireless connection.
- Error messages display on screen if handset fails to connect to access point/wireless router; or if handset fails to connect to PC application in the computer.

WiFi setup

Connection setup on handset

There are four steps on setting up the connection on handset. Follow the instruction closely in this section.

Searching for network

- Press MENU/SEL in idle mode to display menu.
- Use the **UP** or **DOWN** NavKey (^) or (v) to reach Applications, and press MENU/SEL to select.
- Use the **UP** or **DOWN** NavKey to reach Setup Connection, and press MENU/SEL to select.
- The screen displays a warning message about not able to receive call during setting. Press the softkey **YES** to continue setting. Press the softkey **NO** if you do not want to continue.
- After pressing **YES**, the screen displays Searching for available network...
- The screen displays a list of available networks. If you find a security lock symbol (🔒) next to the network name, it means that the network is locked with a security key or password, and you need a security key to unlock it.(go to the section Secutiy lock on how to unlock)
- You can press the softkey **RESCAN** to scan again for available networks if you wish.
- If you choose the network without a security lock, use the **UP** or **DOWN** NavKey (^) or (v) to reach the choice, and press MENU/SEL to confirm, and proceed to the section Enter PC IP address.

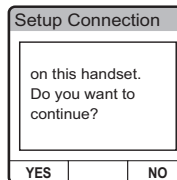
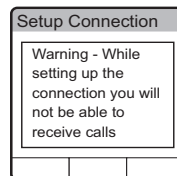

WiFi setup

Security key setup

The security type that the handset supports are WEP (64-bit and 128-bit), WPA and WPA2-PSK. The security code can be up to 64 characters.

- Use the **UP** or **DOWN** NavKey (^) or (v) to reach a network connection with a security lock, and press MENU/SEL to select.
- Use the dial pad (see Chart of character on page) to enter the security key. Use the NavKey to reach Setup Connection, and press MENU/SEL to select. Press the softkey DELETE to delete character.
- Press **MENU/SEL** to save the security key, and proceed to **Enter PC IP address**.

Enter PC IP address

- Use the dial pad to enter the IP address, which is available in PC application.
- Use the **LEFT** or **RIGHT** NavKeys or to move the cursor to the left or right. Use softkey **DELETE** to delete the digit where the cursor is on. Press the **MENU/SEL** to confirm.
- The screen displays message that it is trying to connect. Once the message of Setup successful is displayed. The WiFi setup is done, and the Applications menu is displayed.

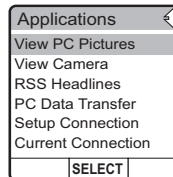
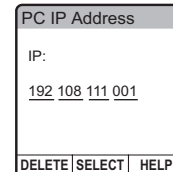
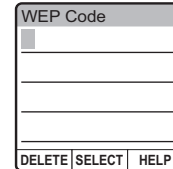
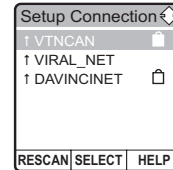

- WEP (Wired Equivalent Privacy) refers to a security protocol for wireless local networks which are defined in the 802.11b standard.
- WPA means Wi-Fi Protected Access.
- PSK refers to the pre-shared key, meaning every user is given the same passphrase.



WiFi setup

Setup connection errors

Incorrect setup may lead to connection errors, and you will be instructed on how to correct the setup in this section.

Error-Cannot associate to XXX network - select another network?





- For this error, press the softkey **YES** to search for another network, and the screen displays the searching network screen, and refer to the section Searching network.
- Pressing the softkey **NO** will prompt you to check the security key. Press the softkey **YES** or **NO** to confirm . Pressing **YES** will proceed to the security setting menu. Pressing **NO** will proceed to next error, or end setup mode.

Error-Cannot connect to VTech PC software make sure it is running on the PC

- For this error, press the softkey **MORE** will prompt you to re-check the PC IP address. Press the softkey **YES** to confirm and refer to the section **PC IP address**. Press the softkey **NO** to go to next error, or end setup mode.
- Check on your PC to make sure the VTech PC software is running.

Check current setup

You can check your current connection setup, and edit it in this menu.

- Press **MENU/SEL** in idle mode to display menu.
- Press the **UP** or **DOWN** NavKey  or  to reach **Applications**, and press **MENU/SEL** to select.
- Press the **UP** or **DOWN** NavKey  or  to reach **Current Connection**, and press **MENU/SEL** to select.
- Pressing the **DOWN** NavKey  will proceed from IP address to connection status, and finally exit the menu.

PC applications software

Recordable ringer

Record a sound clip by using the audio patch cord

- Insert the 3.5mm plug (the larger end) into the headset jack of your PC or audio source. Then insert the 2.5mm plug (the smaller end) into the headset jack on the side of the handset.
- Press **MENU/SEL** when in idle mode.
- Press the **UP** NavKey ▲ three times to reach **Sounds**, and press **MENU/SEL** to select.
- Press the **DOWN** NavKey ▼ once to reach **Record Sound Clips**, and press **MENU/SEL** to select.
- Press the **DOWN** NavKey ▼ once to reach **Using Audio Cable**, and press **MENU/SEL** to select.
- Listen to the music through your handset speaker. Adjust the recording volume at the audio source to the desired volume level.
- Press the softkey **RECORD** to start recording, and press the softkey **STOP** when finished.
- Press the softkey **STOP** when finished.
- Press the softkey **PLAY** to play the sound clip recorded. Press the softkey **STOP** to stop playing anytime.
- Press the softkey **SAVE** if you want to save this sound clip.
- Use the dial pad to enter the **Sound Clip Name**.



- The handset can store a maximum of 50 sound clips, and the maximum recording time per sound clip is 15 seconds.
- The handset is preset with 17 musical ringer options as your default ringer or a distinctive ringer. Four of the ringers are protected and cannot be deleted. You can replace the other ringers with your own recordings.
- If the memory is full, the handset will show **Sound Clip memory full**.



- When you want to use the microphone on the handset to record ringers, do not insert the audio patch cord into the headset jack.

PC applications software

- Press the softkey **SET** when finished. The screen displays **Sound Clip saved**, and there will be a confirmation tone.

Record a sound clip by using the microphone

- Press **MENU/SEL** when in idle mode.
- Press the **UP** NavKey ▲ three times to reach **Sounds**, and press **MENU/SEL** to select.
- Press the **DOWN** NavKey ▼ once to reach **Record Sound Clips**, and press **MENU/SEL** to select.
- Press **MENU/SEL** to select **Using Microphone**, and the screen displays **Record after tone**.
- Position your audio source facing the handset microphone and the handset will start recording after the beep.
- Press the softkey **STOP** when finished.
- Press the softkey **PLAY** to listen to the sound clip you just recorded. Press the softkey **STOP** to stop playing anytime.
- Press the softkey **SAVE to save this sound clip**.
- Use the dial pad to enter the **Sound Clip Name** (up to ten characters).
- Press the softkey **SET** when finished. The screen displays **Sound Clip saved**, and there will be a confirmation tone.



Special features

Picture download

Getting started

The VTech Phonebook Manager allows you to download pictures and edit your handset phonebook from your PC. It also allows you to import and export contacts to and from comma separated text files. This feature allows you to get contacts from your existing PC applications such as Microsoft Outlook® or Palm® programs.

One-time software installation

- Insert the enclosed VTech Phonebook Manager CD into your personal computer.
- An installation window will open on the monitor giving you three options:
 1. Install/Uninstall the Phonebook Manager software.
 2. Browse the Installation CD.
 3. Visit VTech on the web.
- To install the software, click on the **Install/Uninstall the VTech Phonebook Manager** icon  and follow the instructions for downloading.
- After the installation is complete, you will find a VTech Phonebook Manager icon  on your PC desktop.

Graphics tab functions

The VTech Phonebook Manager allows you to open graphic files on your PC and transfer them to your telephone. Once the graphics are transferred, they can be used for your wallpaper image or to be assigned to a particular phonebook entry, quickly alerting you to your caller's identification.

With the phonebook manager, you can also modify the graphic prior to sending it to the handset. Common graphic editing functions such as zoom, rotate, brightness/contrast adjustment and red/green color balance adjustments can be adjusted from the VTech phonebook manager.

Special features

Picture download



Open a graphic file

- Open the phonebook manager by double-clicking on the desktop icon: 
- Click on the Graphics tab.
- Click on the **OPEN IMAGE** button.
- A window will open for you to browse through the graphic file on your computer.
- Find the folder containing your graphic file and double-click to open it.

Picture download

Once a graphic file is opened, it can be transferred from your PC to your handset. There are many images in the phonebook manager software for downloading into your handset, or you can transfer your own pictures onto the handset. The phonebook manager supports the following graphic formats: GIF, JPEG, BMP, TIFF and PNG.

To transfer images from the software to the handset:

- Connect one end of the enclosed USB cable to the handset and the other end to your PC.
- If you have the phonebook manager program open, you should see from the status bar in the bottom right corner update that the PC has detected the telephone. You are now ready to transfer a graphic to the telephone. 
- Following the steps in **Open a Graphic File**.
- Once you have opened the desired image, click on the **Transfer to Handset button**. 
- The graphic transfer will now begin and complete in approximately four seconds.
- When the graphic transfer is complete, follow the instructions given on the handset display to save the graphic to your telephone.

Special features

Picture download

Graphic editing

The VTech Phonebook Manager allows you to perform basic graphic editing functions such as zoom, rotate, brightness/contrast and color balance. When using these tools to edit your pictures, you can see them on the preview panel on the left side of the phonebook manager application.

While in graphic edit mode, there is a red preview box over the center of the main graphic panel. This preview box contains the image shown in the preview panel on the left side of the application. You can move the preview box by:

1. Move the mouse pointer inside the red preview box.
2. Press and hold the left mouse button.
3. Use the mouse to move the red preview box to a new location on the graphic.
4. Once the preview box is on the desired graphic, release the mouse button.



- None of the graphic editing functions will alter the actual graphic file – they will only modify how the graphic will look once it has been downloaded to the handset.



- The phonebook manager application does not perform any synchronization of the phonebook between the PC and the handset. When the **Transfer to Handset** button is pressed, the entire phonebook is transferred to the handset replacing the existing phonebook on the handset.
- This operation will replace the phonebook on your handset with the new one currently transferred from the phonebook manager.

Special features



Phonebook tab functions

The VTech Phonebook Manager can be used to create, modify and backup phonebook files from your handset. The phonebook manager has many useful functions:

- Export existing contacts from any contact manager (such as Microsoft Outlook®, Palm®, etc.) to a comma separated text file. Import those contacts into the phonebook manager and transfer the entire phonebook to your handset.
- Transfer the phonebook from your handset to your PC and save it to disk. Connect a different handset and transfer the phonebook from your PC to the new handset. This allows you to store a copy of the phonebook on your PC and transfer it to different handsets.
- Use the phonebook manager to backup your handset phonebook onto your PC. If you need to restore the phonebook on your handset, there is already a copy stored on your PC.
- Use the phonebook manager to create a phonebook offline on your PC. When finished editing, connect your handset and transfer it from the PC to your handset.

Creating an empty phonebook

To create an empty phonebook to input data:

- Double-click on the VTech Phonebook Manager icon on your PC.
 - Click on the Phonebook tab.
 - Select the **CREATE PHONEBOOK**  button.
 - Using the Phonebook Manager application, make any necessary changes to the phonebook. You can add entries or import contacts from other PC applications such as Microsoft Outlook® or Palm®.
 - When finished editing the phonebook, you must either save the data to your hard drive or transfer it to your handset:
 - Select the **SAVE PHONEBOOK**  button to save the data to your PC's hard drive.
- OR-



Special features

Phonebook tab functions

- Click on Transfer

Edit a phonebook

You can either open an existing phonebook stored in your PC's hard drive by pressing the **OPEN PHONEBOOK**  button using the phonebook manager software, or by transferring the phonebook from your handset to the phonebook manager software using the supplied USB cable. To accomplish this:

- Connect your handset to your PC using the USB cable.
- Start the phonebook manager application on your PC.
- Verify the connection by ensuring the green icon on the status bar. (If it is not, re-connect the handset to the PC with the USB cable.)
- Press the **Phonebook** tab.
- Press the **Transfer**  button.
- Using the phonebook manager software, edit the phonebook entries. At this time you can also add new entries or import contacts from other programs such as Microsoft Outlook® or Palm®, etc.
- When finished editing the phonebook, save it to your PC's hard drive by pressing the **SAVE PHONEBOOK**  button. To transfer the newly edited phonebook to your handset, use the transfer phonebook  button.





- For first time users, try the import operation on an empty phonebook until you have mastered the process.

Special features

Phonebook tab functions

Import contacts into phonebook manager from other PC applications

Use this feature to import contacts from a comma separated text file into the VTech phonebook manager software. The contacts will be merged into the currently loaded phonebook.

1. Create a comma separated text file containing the contacts for importing into your handset. This is accomplished by using the export function from your other contact management application (such as Microsoft Outlook®, Outlook Express® or Palm® applications). The export function in these programs is normally located under the file menu. Be sure to specify the export file as a text file or comma separated file (CSV). An example of exporting contacts from Microsoft Outlook® is as follows:
 - a. Start Microsoft Outlook® on your PC.
 - b. Select **import/export** from the file menu.
 - c. Select **export** to file and press **next**.
 - d. Select a file type of comma separated values (in Windows).
 - e. Select the folder containing the contacts for export.
 - f. Once a contact folder has been selected, press **next**.
 - g. Enter a file name to save as a contact. This will be the file importing into the phonebook manager program. Be sure to make note of where on your PC you save the file for later reference.
2. Start the VTech phonebook manager program on your PC. Load the newly created phonebook into the phonebook manager software using these steps:
 - Press the Transfer  button.
 - Press the **CREATE PHONEBOOK**  button to create an empty phonebook.
 - Press the **OPEN PHONEBOOK**  button to load the previously saved phonebook from your PC's hard drive.

Special features

Phonebook tab functions

- Press the **Import/Export**  button.
- Select **Import Contacts** and press the **next** button.
- Use the browse button to locate the comma separated text file saved in step one. Press **next**.
- The next screen displays how the fields from the comma separated text file will be mapped to the handset phonebook entries. There are two fields in the VTech phonebook: name and number. However, most PC contact managers separate names into the first and last name fields. To allow import of this type of file, the mapping dialog allows you to decide how the name fields from your import file will be placed in the VTech phonebook name field. For example, the following mappings will import the field's first name and last name into the VTech name field. The home phone field will be imported into the VTech phone number field.

If the mapping displayed is not what is desired, select one of the rows and press the **Change Map** button to correct it. You can only use each of the three fields (VTech name first, VTech name last and VTech phone number) once. If you want to change one that has already been mapped, you must first select that row and use the **Change Map** button to remove the association.

- When finished editing the mapping, press the **Finish** button. The contacts will now be imported and merged into the currently loaded phonebook.

Exporting contacts to a comma separated text file

This feature allows you to export some or all of your VTech phonebook entries into a comma separated text file. This comma separated text file can then be imported into a contact manager software such as Microsoft Outlook® or Palm® applications.

- Load a phonebook into the phonebook manager.
- If you wish to export only some of your contacts, select the desired contacts on the list of contacts loaded. You can use your mouse to select to a single row or hold down the CTRL key while using your mouse to click on the rows to be selected.
- Press the **Import/Export**  button.

Special features

Phonebook tab functions

- Select **Export Contacts** and press the **next** button.
- Select whether you want to **Export All Contacts** or **Selected Contacts**.
- Enter the name of the file to be exported to. You can use the **browse** button to locate the folder and enter a file name.
- Press the **Finish** button to complete the export operation.

Deleting phonebook records from the currently loaded phonebook

- Start the phonebook manager software on your PC.
- Press the Phonebook tab.
- Load a phonebook into the phonebook manager.
- Select the rows of the phonebook entries to be deleted. Use your mouse to select a single row or hold down the CTRL key while using your mouse to click on the rows to be selected.
- Press the **Delete Selected Contacts**  button.
- Save the file to disk and/or transfer it to the handset.

Handset and base indicators

Handset icons



Line in use indicator

- On when an extension handset or parallel set is in use.

Hold indicator

- Flashes when a call is on hold.



Mute indicator

- Flashes when the handset microphone is muted.





Ringer off indicator

-  displays when the ringer is turned off.



Battery indicator

- When the handset is removed from the charger, this lets you know the level of charge in the battery, from **FULL** () to **EMPTY** ()
- Cycles (low, medium, and full) when handset battery is charging.
- Flashes when a low battery condition is detected.



New message indicator

- Flashes when there is a new message in the answer system.





Handset LEDs



- On when the handset speakerphone is in use.

Handset indicators

Handset icons

Icon	Description
	<ul style="list-style-type: none">• The microphone is muted.
NEW	<ul style="list-style-type: none">• Displayed when viewing a missed call that has not been reviewed.
	<ul style="list-style-type: none">• The handset ringer is off.
	<ul style="list-style-type: none">• Low battery indicator or charging indicator.
	<ul style="list-style-type: none">• Flashes to indicate that there are new voicemail messages. (Service must be subscribed from your telephone company.)

Add additional headsets

Your telephone can accommodate up to eight cordless handsets. You can add new handsets (VTech i5808, purchased separately) anytime. Up to three handsets can be on a call at the same time.

The handset provided with your telephone system is automatically registered as Handset 1 (i5871), or Handset 1 and Handset 2 (for i5873). Additional handsets will be assigned in numerical order (2, 3, 4, etc.) when they are registered.

Before using a separately purchased handset, it must be registered with the base unit.

The maximum number of handsets for use at any time is three, and the possible combinations include:

- Three handsets and the base unit on an external call.
- Two handsets and the base unit on an external call, and one handset accessing the answering system.
- One handset and the base unit are on an external call, and two handsets are on intercom.

Registration of handset

- Make sure the additional handset is fully charged before registration.
- On the base unit, press the softkey **MENU** in idle mode.
- Press the softkey ▼ three times to reach **REGISTER HANDSET**, and press the softkey **SELECT** to select.
- The base unit screen displays **READY TO REGISTER NEW HANDSET**, press the softkey **REGISTER** on the handset.
- The handset screen displays **Registration in Progress**. Within 15-60 seconds, the screen displays **Found Base**, and the base unit and handset will beep.

Add additional handsets

- The newly registered handset will be assigned the lowest extension number which has not been previously assigned to another system handset (2 through 8 for model i5871, 3 through 8 for model i5873).

Replace a handset

If you are replacing a handset on a system that has the maximum number of registered handsets (eight) or wish to change the assigned handset number of your registered handsets, you must first de-register the handsets, and then register all handsets again.

De-register a handset

- On the handset to be de-registered, press **MENU/SEL** when in idle mode.
- Press the **DOWN** NavKey ▼ four times to reach **Settings**, and press **MENU/SEL** to select.
- Press the **UP** NavKey ▲ once to reach **Reset Settings**, and press **MENU/SEL** to select.
- Press the **UP** NavKey ▲ twice to reach **Clear Registration**, and press **MENU/SEL** to select.
- The screen displays **Clear Handset Registration Are you sure?** Press the softkey **YES** to confirm, or press the softkey **NO** if you decide to keep the registration.
- The screen will then display the instructions for registering a handset.

Add additional handsets

De-register all handsets

- On the base unit, press the softkey **MENU**.
- Press the softkey ▼ once to reach **BASE SETTINGS**, then press the softkey **SELECT** to select.
- Press the softkey ▲ twice to reach **DELETE HANDSETS**, and press the softkey **SELECT** to select.
- The screen displays **DELETE REGISTRATION FOR ALL HANDSETS ARE YOU SURE?** Press the softkey **YES** to confirm, or press the softkey **NO** if you decide to keep the registration.

To re-register a handset, see **Registration of handset** on page XX.



- When using your phone during power backup mode, audio quality may be compromised due to reduced power availability.

Charge spare battery pack

Power guard feature

Your phone uses a spare battery charger in the base unit to provide power backup in the event of a power failure or outage. With a fully charged battery in the spare battery charger, you will be able to make and receive calls for up to 2.5 hours during a power outage.

The spare battery can also be used to replace a depleted handset battery to ensure uninterrupted use. The spare battery is optional and can be purchased separately.

Installation

1. Open the spare battery compartment by pressing the release button located on the bottom of the base unit.
2. Remove the battery cover and place the battery in the compartment with the metal contacts aligned, as shown in the diagram.
3. Replace the compartment cover. The spare battery charger takes 20 hours to fully charge a depleted battery.

Batteries

After the battery is fully charged, you can expect the following performance:

Operation	Operating time
While in use (talking)	6 hours
While not in use (standby*)	96 hours (approximately 4 days)

*Handset is off the base unit but not in use.

The battery needs charging when:

- A new battery is installed in the handset.
- The telephone beeps twice once taken off the base unit.
- Battery indicator on screen is empty.

CAUTION:

To reduce the risk of fire or injury to persons, read and follow these instructions:

1. Use only the battery(ies) specified.
2. Do not dispose of the battery(ies) in a fire. They may explode. Check with local waste management codes for special disposal instructions.
3. Do not open or mutilate the battery(ies). Released electrolyte is corrosive and may cause burns or injury to the eyes or skin. The electrolyte may be toxic if swallowed.
4. Exercise care in handling batteries in order not to short the battery to conductive materials such as rings, bracelets, and keys. The battery and/or conductor may overheat and cause burns.
5. Charge the battery(ies) provided with or identified for use with this product only in accordance with the instructions and limitations specified in this manual.

WARNING:

TO PREVENT FIRE OR SHOCK HAZARD, DO NOT EXPOSE THIS PRODUCT TO RAIN OR ANY TYPE OF MOISTURE.

The AC adapter is used as the main disconnect device, ensure that the AC outlet is located/installed near the unit and is easily accessible.

Important safety instructions

When using your telephone equipment, basic safety precautions should always be followed to reduce the risk of fire, electric shock and injury, including the following:

1. Read and understand all instructions.
2. Follow all warnings and instructions marked on the product.
3. Unplug this product from the wall outlet before cleaning. Do not use liquid or aerosol cleaners. Use a damp cloth for cleaning.
4. Do not use this product near water (for example, near a bathtub, kitchen sink, or swimming pool).
5. Do not place this product on an unstable surface, such as a table, shelf or stand. This product may fall, causing serious damage.
6. Slots and openings in the back or bottom of the base unit and handset are provided for ventilation. To protect them from overheating, these openings must not be blocked by placing the product on a soft surface such as a bed, sofa or rug. This product should never be placed near or over a radiator or heat register. This product should not be placed in any area where proper ventilation is not provided.
7. This product should be operated only from the type of power source indicated on the marking label. If you are not sure of the type of power supply in your home, consult your dealer or local power company.
8. Do not allow anything to rest on the power cord. Do not install this product where the cord may be walked on.
9. Never push objects of any kind into this product through slots in the base or handset as they may touch dangerous voltage points or short out parts that could result in a risk of fire or electric shock. Never spill liquid of any kind on the product.
10. To reduce the risk of electric shock, do not disassemble this product, but take it to an authorized service facility. Opening or removing parts of the base or handset other than specified access doors may expose you to dangerous voltages or other risks. Incorrect reassembling can cause electric shock when the product is subsequently used.
11. Do not overload wall outlets and extension cords as this can result in the risk of fire or electric shock.
12. Unplug this product from the wall outlet and refer servicing to an authorized service facility under the following conditions:
 - A. When the power supply cord or plug is damaged or frayed.
 - B. If liquid has been spilled onto the product.
 - C. If the product has been exposed to rain or water.
 - D. If the product does not operate normally by following the operating instructions. Adjust only those controls that are covered by the operation instructions, as improper adjustment of other controls may result in damage and often requires extensive work by an authorized technician to restore the product to normal operation.
 - E. If the product has been dropped and the base and/or handset has been damaged.
 - F. If the product exhibits a distinct change in performance.
13. Avoid using a telephone (other than cordless) during an electrical storm. There is a remote risk of electric shock from lightning.
14. Do not use the telephone to report a gas leak in the vicinity of the leak.
15. Only put the handset of your telephone next to your ear when it is in normal talk.

CAUTION: Use only the power adapter provided with this product. To obtain a replacement, call 1 (800) 222-3111. In Canada, call 1 (866) 288-4268.

SAVE THESE INSTRUCTIONS

Troubleshooting

If you have difficulty operating your telephone, the suggestions below should solve the problem. If you still have difficulty after trying these suggestions, call VTech Communications at 1(800)595-9511. In Canada, call VTech Telecommunications Canada Ltd. at 1(800)267-7377.

Problem	Suggestion
My telephone doesn't work at all.	<ul style="list-style-type: none">• Make sure the power adaptor is plugged in.• Make sure the telephone line cord is plugged firmly into the base unit and the telephone wall jack.• Disconnect the power adaptor for a few minutes, and then reconnect it.• Charge the battery in the handset for 16 hours. For optimum daily performance, return the handset to its base unit when not in use.• Reset the base unit. Unplug the electrical power. Wait for 15 seconds then plug it back in. Allow up to one minute for the handset and base unit to reset.• You may need to purchase a new battery, please refer to the Batteries sections in this user's manual.
I cannot get a dial tone.	<ul style="list-style-type: none">• Try all the suggestions above.• Move the handset closer to the base unit. You might have moved out of range.• Make sure the telephone is set to the correct dial mode for the type of service that you have (pulse or touchtone). Refer to the Installation section of this user's manual to set the dial mode.• Your line cord might be malfunctioning. Try installing a new line cord.• If the previous suggestions do not work, disconnect the telephone base from the telephone jack and connect a different telephone. If there is no dial tone on that telephone either, the problem is in the wiring or local service. Contact your local telephone company.

Troubleshooting

Problem	Suggestion
I cannot dial out.	<ul style="list-style-type: none">• Make sure there is a dial tone before dialing. It is normal for handset to take a second or two to find the base unit and produce a dial tone. Wait an extra second before dialing.• If the other telephones in your home are having the same problem, the problem is in your wiring or local service. Contact your local telephone company.• Eliminate any background noise. Noise from a television, radio or other appliance may cause the telephone not to dial out properly. If you cannot eliminate the background noise, first try muting the handset before dialing, or dialing from another room in your home with less background noise.
The batteries do not hold a charge.	<ul style="list-style-type: none">• Charge the battery in the handset for 16 hours. For optimum daily performance, return the handset to its base unit when not in use.• You may need to purchase a new battery, please refer to the Batteries section in this user's manual.• Your telephone might be malfunctioning. Please refer to the Warranty section of this user's manual for further instruction.

Troubleshooting

Problem	Suggestion
I get noise, static, or weak signal even when I'm near the telephone base.	<ul style="list-style-type: none">• Other electronic products can cause interference with your cordless telephone. Try installing your telephone away from these types of electronic devices: wireless routers, radios, radio towers, pager towers, cell phones, intercoms, room monitors, televisions, personal computers, kitchen appliances and other cordless telephones.• Microwave oven operates on the same frequency as your telephone. It is normal to experience static on your telephone while the microwave oven is running. Do not install this telephone in the same outlet or near the microwave oven.• If your telephone is plugged in with a modem or surge protector, plug the telephone (or modem/surge protector) into a different location. If this solves the problem, re-locate your telephone or modem farther apart from one another, or use a different surge protector.• Relocate your base unit to a higher location. The telephone will likely get better reception if not installed in a lower area.• If the other telephones in your home are having the same problem, the problem is in your wiring or local service. Contact your local telephone company (charges may apply).
I hear noise in the handset, and none of the keys or buttons work.	<ul style="list-style-type: none">• Make sure the power cord is plugged in.
I hear other calls while using my telephone.	<ul style="list-style-type: none">• Disconnect your base unit from the telephone jack, and plug in a regular telephone. If you still hear other calls, the problem is probably in your wiring or local service. Call your local telephone company.

Troubleshooting

Problem	Suggestion
My handset does not ring when I receive a call.	<ul style="list-style-type: none">• Make sure you have the ringer activated. Refer to the section(s) on ringer selection in this user's manual.• Make sure the telephone line cord is plugged firmly into the base unit and the telephone jack. Make sure the power cord is plugged in.• The handset may be too far from the base unit.• Charge the battery in the handset for 16 hours. For optimum daily performance, return the handset to its base unit when not in use.• You may have too many extension telephones on your telephone line to allow all of them to ring. Try unplugging some of the other telephones.• The layout of your home or office might be limiting the operating range. Try moving the telephone base to another location, preferably on an upper floor.• If the other telephones in your home are having the issue, the problem is in your wiring or local service. Contact your local telephone company (charges may apply).• Test a working telephone at the telephone jack. If another telephone has the same problem, the problem is the telephone jack. Contact your local telephone company (charges may apply).• Other electronic products can cause interference with your cordless telephone. Try installing your telephone as far away from these types of electronic devices as possible: wireless routers, radios, radio towers, pager towers, cell phones, intercoms, room monitors, televisions, personal computers, kitchen appliances and other cordless telephones• Your line cord might be malfunctioning. Try installing a new line cord.

Troubleshooting

Problem	Suggestion
My calls fade or cut in and out while I'm using my handset.	<ul style="list-style-type: none">• Other electronic products can cause interference with your cordless telephone. Try installing your telephone as far away from these types of electronic devices as possible: wireless routers, radios, radio towers, pager towers, cell phones, intercoms, room monitors, televisions, personal computers, kitchen appliances and other cordless telephones.• Microwave oven operates on the same frequency as your telephone. It is normal to experience static on your telephone while the microwave oven is running. Do not install this telephone in the same outlet or near the microwave oven.• If your telephone is plugged in with a modem or surge protector, plug the telephone (or modem/surge protector) into a different location. If this solves the problem, re-locate your telephone or modem farther apart from one another, or use a different surge protector.• Relocate your telephone base to a higher location. The telephone will get better reception if not installed in a lower area.• If the other telephones in your home are having the issue, the problem is in your wiring or local service.
My caller ID isn't working.	<ul style="list-style-type: none">• Caller ID is a subscription service. You must subscribe to this service for this feature to work on your telephone.• Your caller must be calling from an area that supports caller ID.• Both you and your caller's telephone companies must use caller ID compatible equipment.

Troubleshooting

Problem	Suggestion
Common cure for electronic equipment	<p>If the unit does not seem to be responding normally, then try putting the handset in its telephone base. If it does not seem to respond, do the following (in the order listed):</p> <ol style="list-style-type: none"><li data-bbox="368 273 848 296">1. Disconnect the power to the telephone base.<li data-bbox="368 304 1043 327">2. Disconnect the handset battery, and spare battery, if applicable.<li data-bbox="368 335 591 358">3. Wait a few minutes.<li data-bbox="368 366 779 389">4. Connect power to the telephone base.<li data-bbox="368 397 654 420">5. Re-install the battery(ies).<li data-bbox="368 428 1332 482">6. Wait for the handset to re-establish its link with the telephone base. To be safe, allow up to one minute for this to take place.

Operating range

This cordless telephone operates with the maximum power allowed by the Federal Communications Commission (FCC). Even so, this handset and telephone base can communicate over only a certain distance ----which can vary with the locations of the telephone base and handset, the weather, and the layout of your home or office.

When the handset is out of range, the handset will display **Searching**. The user can access the handset phonebook, and certain parts of the menu system, i.e. handset setting and registration, but not the time setting and base setting. **Not possible** will be displayed if access is tried.

If there is a call while the handset is out of range, it might not ring, or if it does ring, the call might not connect well when you press TALK/FLASH. Move closer to the telephone base, then press TALK/FLASH to answer the call.

If the handset moves out of range during a telephone conversation, there might be interference.

To improve reception, move closer to the base.

Maintenance

Taking care of your telephone

Your cordless telephone contains sophisticated electronic parts, so it must be treated with care.

Avoid rough treatment

Place the handset down gently. Save the original packing materials to protect your telephone if you ever need to ship it.

Avoid water

Your telephone can be damaged if it gets wet. Do not use the handset outdoors in the rain, or handle it with wet hands. Do not install your base unit near a sink, bathtub or shower.

Electrical storms

Electrical storms can sometimes cause power surges harmful to electronic equipment. For your own safety, use caution when using electric appliances during storms.

Cleaning your telephone

Your telephone has a durable plastic casing that should retain its luster for many years. Clean it only with a soft cloth slightly dampened with water or a mild soap. Do not use excess water or cleaning solvents of any kind.

Remember that electrical appliances can cause serious injury if used when you are wet or standing in water. If your base unit should fall into water, DO NOT RETRIEVE IT UNTIL YOU UNPLUG THE POWER CORD AND TELEPHONE LINE CORDS FROM THE WALL. Then pull the unit out by the unplugged cords.

About cordless telephones

- **Privacy:** the same features that make a cordless phone convenient create some limitations. Telephone calls are transmitted between the base and the cordless handset by radio waves, so there is a possibility that your cordless phone conversations could be intercepted by radio receiving equipment within range of the cordless handset. For this reason, you should not think of cordless phone conversations as being as private as those on corded phones.
- **Electrical Power:** The base unit of this cordless telephone must be connected to a working electrical outlet. The electrical outlet should not be controlled by a wall switch. Calls cannot be made from the cordless handset if the base unit is unplugged or switched off, or if the electrical power is interrupted.
- **Potential TV Interference:** Some cordless telephones operate at frequencies that may cause interference to televisions and VCRs. To minimize or prevent such interference, do not place the base unit of the cordless telephone near or on top of a TV or VCR. If interference is experienced, moving the cordless telephone farther away from the TV or VCR will often reduce or eliminate the interference. (Applies to 25 channel cordless phones only).
- **Rechargeable Batteries:** This product contains either Nickel-Cadmium or Nickel-Metal Hydride rechargeable batteries. Exercise care in handling batteries in order not to short the battery with conducting material such as rings, bracelets, and keys. The battery or conductor may overheat and cause harm. Observe proper polarity between the battery and the battery charger.
- **Nickel-Metal Hydride Rechargeable Batteries:** Dispose of these batteries in a safe manner. Do not burn or puncture. Like other batteries of this type, if burned or punctured, they could release caustic material which could cause injury.

Warranty

What does this limited warranty cover?

The manufacturer of this Vtech product, Vtech Communications, warrants to the holder of a valid proof of purchase ("Consumer" or "you") that the product and all accessories provided by Vtech in the sales package ("Product") are free from material defects in material and workmanship, pursuant to the following terms and conditions, when installed and used normally and in accordance with operation instructions. This limited warranty extends only to the Consumer for Products purchased and used in the United States of America.

What will Vtech Communications do if the Product is not free from material defects in materials and workmanship during the limited warranty period ("Materially Defective Product")?

During the limited warranty period, Vtech's authorized service representative will repair or replace at Vtech's option, without charge, a Materially Defective Product. If we repair this product, we may use new or refurbished replacement parts. If we choose to replace this product, we may replace it with a new or refurbished product of the same or similar design. Vtech will return repaired or replacement products to you in working condition. Vtech will retain defective parts, modules, or equipment. Repair or replacement of Product, at Vtech's option, is your exclusive remedy. You should expect the repair or replacement to take approximately 30 days.

How long is the limited warranty period?

The limited warranty period for the product extends for ONE (1) YEAR from the date of purchase if we repair or replace a Materially Defective Product under the terms of this limited warranty. This limited warranty also applies to repaired or replacement Products for a period of either (a) 90 days from the date the repaired or replacement Product is shipped to you or (b) the time remaining on the original one-year warranty; whichever is longer.

What is not covered by this limited warranty?

This limited warranty does not cover

1. Product that has been subjected to misuse, accident, shipping or other physical damage, improper installation, abnormal operation or handling, negligent, inundation, fire, water or other liquid intrusion; or
2. Product that has been damaged due to repair, alteration or modification by anyone other than an authorized service representative of Vtech; or
3. Product to the extent that the problem experienced is caused by signal conditions, network reliability or cable or antenna systems; or
4. Product to the extent that the problem is caused by use with non-Vtech electrical accessories; or
5. Product whose warranty/quality stickers, Product serial numbers plates or electronic serial numbers have been removed, altered or rendered illegible; or
6. Product purchased, used serviced, or shipped for repair from outside the United States, or used for commercial or institutional purposes (including but not limited to Products used for rental purposes); or

Warranty

7. Product returned without valid proof of purchase (see 2 below); or
8. Charges for installation or set up, adjustment of customer controls, and installation or repair of systems outside the unit.

How do you get warranty service?

- To obtain warranty service in the United States of America, call 1(800)595-9511 for instructions regarding where to return the Product. Before calling for service, please check the user's manual. A check of the Product controls and features may save you a service call.
- Except as provided by applicable law, you assume the risk of loss or damage during transit and transportation and are responsible for delivery or handling charges incurred in the transport of Product(s) to the service location. VTech will return repaired or replaced product under this limited warranty to you, transportation, delivery or handling charges prepaid. VTech assumes no risk for damage or loss of the Product in transit.
- If the Product failure is not covered by this limited warranty, or proof of purchase does not meet the terms of this limited warranty, VTech will notify you and will request that you authorize the cost of repair and return shipping costs for the repair of Products that are not covered by this limited warranty.

What must you return with the Product to get warranty service?

1. Return the entire original package and contents including the Product to the Vtech service location along with a description of the malfunction or difficulty;
2. Include "valid proof or purchase" (sales receipt) identifying the Product purchased (Product model) and the date of purchase or receipt; and
3. Provide your name, complete and correct mailing address, and telephone number.

Other Limitations

- This warranty is the complete and exclusive agreement between you and Vtech. It supersedes all other written or oral communications related to this Product. Vtech provides no other warranties for this product. The warranty exclusively describes all of Vtech's responsibilities regarding the product.

There are no other express warranties. No one is authorized to make modifications to this limited warranty and you should not rely on any such modification.

State Law Rights: This warranty gives you specific legal rights, and you may also have other rights, which vary from state to state.

Limitations: Implied warranties, including those of fitness for a particular purpose and merchantability (an written warranty that the product is fit for ordinary use) are limited to one year from date of purchase. Some states do not allow limitations on how long an implied warranty lasts, so the above limitation may not apply to you.

- In no event shall Vtech be liable for any indirect, special, incidental, consequential, or similar damages (including, but not limited to lost profits or revenue, inability to use the product, or other associated equipment, the cost of substitute equipment, and claims by third parties) resulting from the use of this product, some states do not allow exclusion or limitation of incidental or consequential damages, so the above limitation or exclusion may not apply to you.

FCC, ACTA and IC regulations

FCC Part 15

This device complies with part 15 of the FCC rules. Operation is subject to the following two conditions: 1) This device may not cause harmful interference; and 2) This device must accept any interference received, including interference that may cause undesired operation. Privacy of communications may not be ensured when using this phone.

This equipment has been tested and found to comply with the requirements for a Class B digital device under Part 15 of the Federal Communications Commission (FCC) rules. These requirements are intended to provide reasonable protection against harmful interference in a residential installation. This equipment generates, uses and can radiate radio frequency energy and, if not installed and used in accordance with the instructions, may cause harmful interference to radio communications. However, there is no guarantee that interference will not occur in a particular installation. If this equipment does cause harmful interference to radio or television reception, which can be determined by turning the equipment off and on, the user is encouraged to try to correct the interference by one or more of the following measures:

FCC, ACTA and IC regulations

- Reorient or relocate the receiving antenna.
- Increase the separation between the equipment and receiver.
- Connect the equipment into an outlet on a circuit different from that to which the receiver is connected.

- Consult the dealer or an experienced radio/TV technician for help.

Changes or modifications to this equipment not expressly approved by the party responsible for compliance could void the user's authority to operate the equipment.

To ensure safety of users, the FCC has established criteria for the amount of radiofrequency energy that can be safely absorbed by a user or bystander according to the intended usage of the product. This product has been tested and found to comply with the FCC criteria. The handset may be safely held against the ear of the user. The base unit shall be installed and used such that parts of the user's body other than the hands are maintained at a distance of approximately 20 cm (8 inches) or more. If you choose to use a clipping device, please make sure to only use the supplied VTech belt clip.

FCC Part 68 and ACTA

This equipment complies with Part 68 of the FCC rules and with technical requirements adopted by the Administrative Council for Terminal Attachments (ACTA). The label on the back or bottom of this equipment contains, among other things, a product identifier in the format US:AAAEQ#TXXXX. This identifier must be provided to your local telephone company upon request.

The plug and jack used to connect this equipment to premises wiring and the telephone network must comply with applicable Part 68 rules and technical requirements adopted by ACTA. A compliant telephone cord and modular plug is provided with this product. It is designed to be connected to a compatible modular jack that is also compliant. An RJ11 jack should normally be used for connecting to a single line and an RJ14 jack for two lines. See Installation Instructions in the user's manual.

The Ringer Equivalence Number (REN) is used to determine how many devices you may connect to your telephone line and still have them ring when you are called. The REN for this product is encoded as the 6th and 7th characters following the US: in the product identifier (e.g., if ## is 03, the REN is 0.3). In most, but not all areas, the sum of all RENs should be five (5.0) or less. For more information, please contact your local telephone company.

This equipment may not be used with Party Lines. If you have specially wired alarm dialing equipment connected to your telephone line, ensure the connection of this equipment does not disable your alarm equipment. If you have questions about what will disable alarm equipment, consult your telephone company or a qualified installer.

If this equipment is malfunctioning, it must be unplugged from the modular jack until the problem has been corrected. Repairs to this telephone equipment can only be made by the manufacturer or its authorized agents. For repair procedures, follow the instructions outlined under the Limited Warranty.

If this equipment is causing harm to the telephone network, the telephone company may temporarily discontinue your telephone service. The telephone company is required to notify you before interrupting service. If advance notice is not practical, you will be notified as soon as possible. You will be given the opportunity to correct the problem and the telephone company is required to inform you of your right to file a complaint with the FCC. Your telephone company may make changes in its facilities, equipment, operation, or procedures that could affect the proper functioning of this product. The telephone company is required to notify you if such changes are planned.

If this product is equipped with a corded or cordless handset, it is hearing aid compatible.

If this product has memory dialing locations, you may choose to store emergency telephone numbers (e.g., police, fire, medical) in these locations. If you do store or test emergency numbers, please:

- Remain on the line and briefly explain the reason for the call before hanging up.
- Perform such activities in off-peak hours, such as early morning or late evening.

Industry Canada

FCC, ACTA and IC regulations

This equipment complies with regulations RSS210 and CS-03 of Industry Canada. Operation is subject to the following two conditions: (1) this device may not cause interference, and (2) this device must accept any interference, including interference that may cause undesired operation of the device.

The term "IC: " before the certification/registration number only signifies that the Industry Canada technical specifications were met.

The Ringer Equivalence Number (REN) for this terminal equipment is 0.1. The REN is an indication of the maximum number of devices allowed to be connected to a telephone interface. The termination on an interface may consist of any combination of devices subject only to the requirement that the sum of the RENs of all the devices does not exceed five.

Technical specifications

Frequency control	Crystal controlled PLL synthesizer
Transmit frequency	Handset: 2400-2483.5 MHz
Receive frequency	Handset: 2400-2483.5 MHz
Channels	11
Nominal effective range	Maximum power allowed by the FCC and IC. Actual operating range may vary according to environmental conditions at the time of use.
Size	Handset: 171mm X 48mm X 32mm Charger: 108mm X 95mm X 94mm
Weight	Handset: 144.2 grams (201.4 grams with battery) Charger: 104.8 grams
Power requirements	Handset: 900mAH Ni-MH Battery Charger: AC 9V @ 300mA
Memory	Handset directory: 100 memory locations, up to 32 digits, 16 characters per location Handset Caller ID log: 100 memory locations, 16 character names, 16 digit phone numbers

Index

A

- About caller ID information 4
- About cordless telephones 59
- Add additional headsets 46
- Advanced operation 24–29

B

- Basic operation 14–22
- Batteries 50

C

- Call log 25
- Call waiting 16
- Charge spare battery pack 49
- Chart of characters 24
- Clear voice mail 10
- Conference call 18
- Connection setup on handset 31
- Contrast 10
- Creating an empty phonebook 39

D

- De-register a handset 47
- De-register all handsets 48
- Default settings 11
- Delete all messages 13
- Delete all phonebook entries 23
- Delete an entry 27

- Delete a phonebook entry 23
- Delete a redial entry 29
- Delete registration 11
- Deleting phonebook records from the currently loaded phonebook iii
- Dial a call log entry 26
- Dial an entry from the redial list 28
- Dial mode 4

E

- Edit a phonebook 40
- Edit a phonebook entry 22
- Edit handset name 10
- Exporting contacts to a comma separated text file 42

F

- FCC, ACTA and IC regulations 60–62
- From one handset to all handsets and base unit 17
- From one handset to a specific handset or base unit 18
- From one handset to the base unit or to another handset 18

G

- Getting started 36
- Graphic editing 38
- Graphics tab functions 36

H

- Handset battery installation 2
- Handset icons 44
- Handset indicators 45
- Handset layout 5
- Handset LEDs 44
- Handset messages 13
- Handset screen images 6
- Handset settings 9
- Handset sounds 7
- Headset installation (optional) 3
- Hold 15

I

- Important safety instructions 51
- Import contacts into phonebook manager from other PC applications 41
- Index 64
- Installation 1–4, 49
- Intercom call 17

L

- Language 9

M

- Maintenance 58
- Make, answer, and end calls at the

Index

base unit 14
Make, answer, and end calls with the handset 14
Mute 15

N

Network setup 30

O

One-time software installation 36
Open a graphic file 37
Operating range 58
Options during playback 13
Options while on calls 15

P

Parts checklist 1
PC applications software 34–35
Phone book 21
Phonebook tab functions 39
Picture download 36
Pictures & animations 6
Play the message 12
Power guard feature 49

R

Recordable ringer 34
Record a sound clip by using the audio

67

patch cord 34
Record a sound clip by using the microphone 35
Redial list 28
Registration of handset 46
Replace a handset 47
Review the call log 26
Ringer silencing 16

S

Save an entry to the handset phonebook 27
Save a redial entry to the phonebook on the handset 29
Searching for network 31
Search the phonebook 22
Security key setup 32
Set a wallpaper image 6
Set Ringer melody 7
Set Ringer volume 7
Set time 9
Show handset name 11
Speakerphone on the handset 15
Special features 36–44
Store an entry in the phone book 21

T

Technical specifications 63

Telephone settings 5–13
To transfer images from the software to the handset 37
Transfer an external call 19
Troubleshooting 52–58

V

Volume control 15

W

Warranty 59
WiFi setup 30–32

VTECH TELECOMMUNICATIONS LTD.

A member of THE VTECH GROUP OF COMPANIES.

Distributed in the U.S.A. by VTech Communications, Inc. Beaverton, Oregon

Distributed in Canada by VTech Telecommunications Canada, Ltd., Richmond, B.C.

Copyright ©2006 for VTECH TELECOMMUNICATIONS LTD.

Printed in China.

91-000xxx-010-000



User's Manual

www.vtechphones.com

Model: wf6909

5.8
GHz
DIGITAL