

## Telephone base installation

### **To connect the corded handset and power adaptor to the telephone base**

Plug the large end of the power adaptor into a power outlet not controlled by a wall switch.

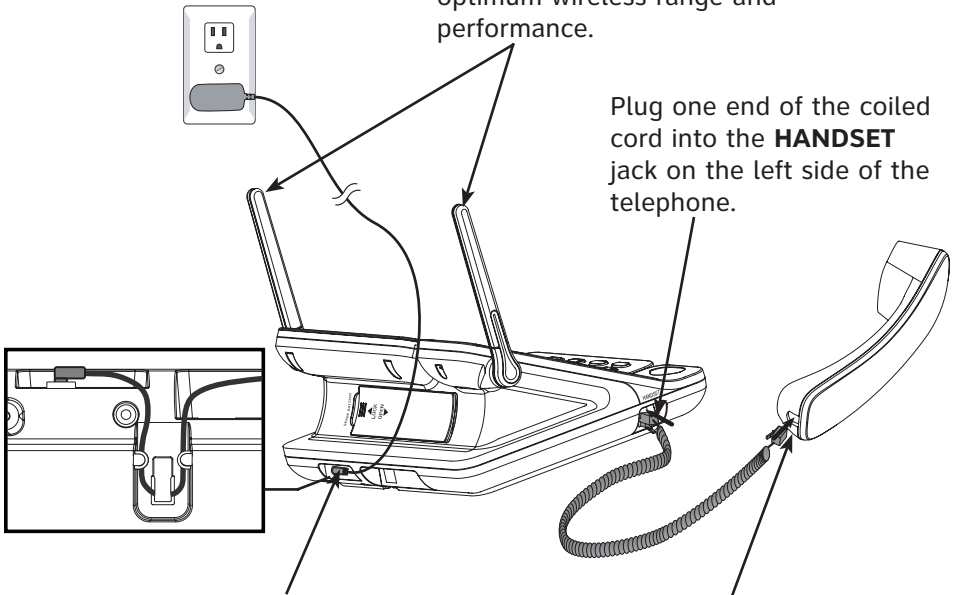

Plug the small end of the power adaptor into the power jack at the bottom of the telephone base. Route the power adaptor cord through the slot on the bottom of the telephone.

Plug the other end of the coiled cord into the corded handset.

**i** **NOTE:** For complete instruction on installing the cordless handset, please refer to the manual provided with your AT&T SB67118/67108 product, or visit [www.telephones.att.com](http://www.telephones.att.com) to download the manual.

### **IMPORTANT INFORMATION**

1. Use only the power adaptor supplied with this product. To order a replacement power adaptor, visit our website at [www.telephones.att.com](http://www.telephones.att.com), or call **1 (800) 222-3111**. In Canada dial **1 (866) 288-4268**.
2. The power adaptor is intended to be correctly oriented in a vertical or floor mount position. The prongs are not designed to hold the plug in place if it is plugged into a ceiling, under-the-table or cabinet outlet.

# Telephone base installation

## To connect the telephone line cords to the telephone base

If you subscribe to high-speed Internet service (digital subscriber line - DSL) through your telephone lines, you must install a DSL filter between the telephone base and the telephone wall jack. The filter will prevent noise and caller ID problems caused by DSL interference. Please contact your DSL service provider for more information about DSL filters.

Install the telephone line cords as shown below.

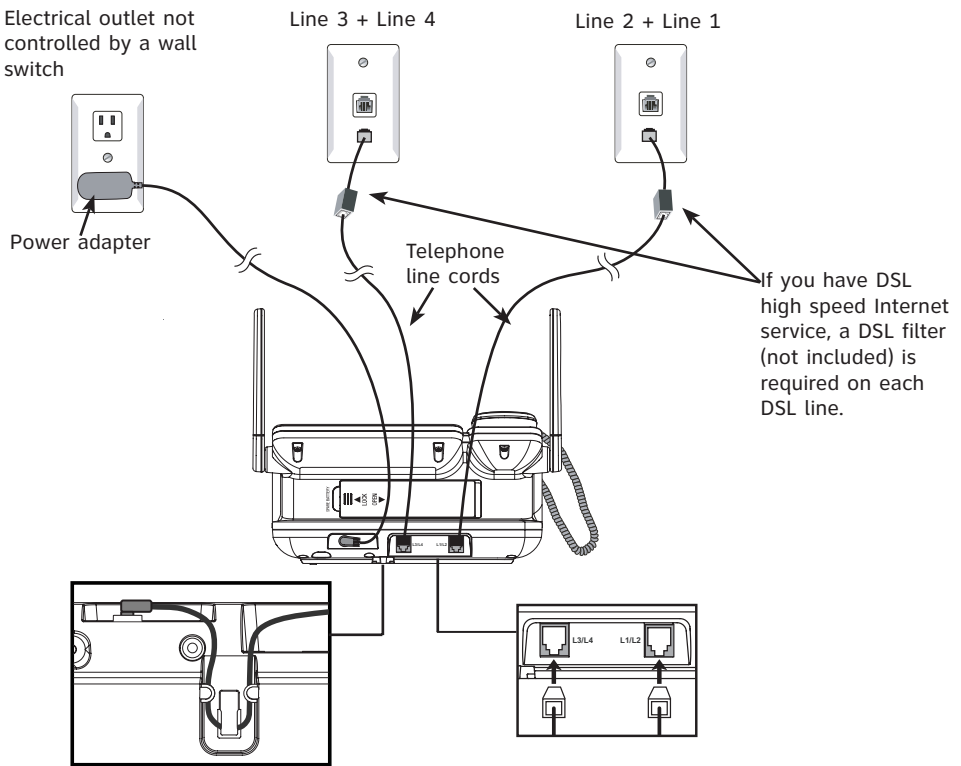

Option 1: To connect two 2-line wall jacks

# Telephone base installation

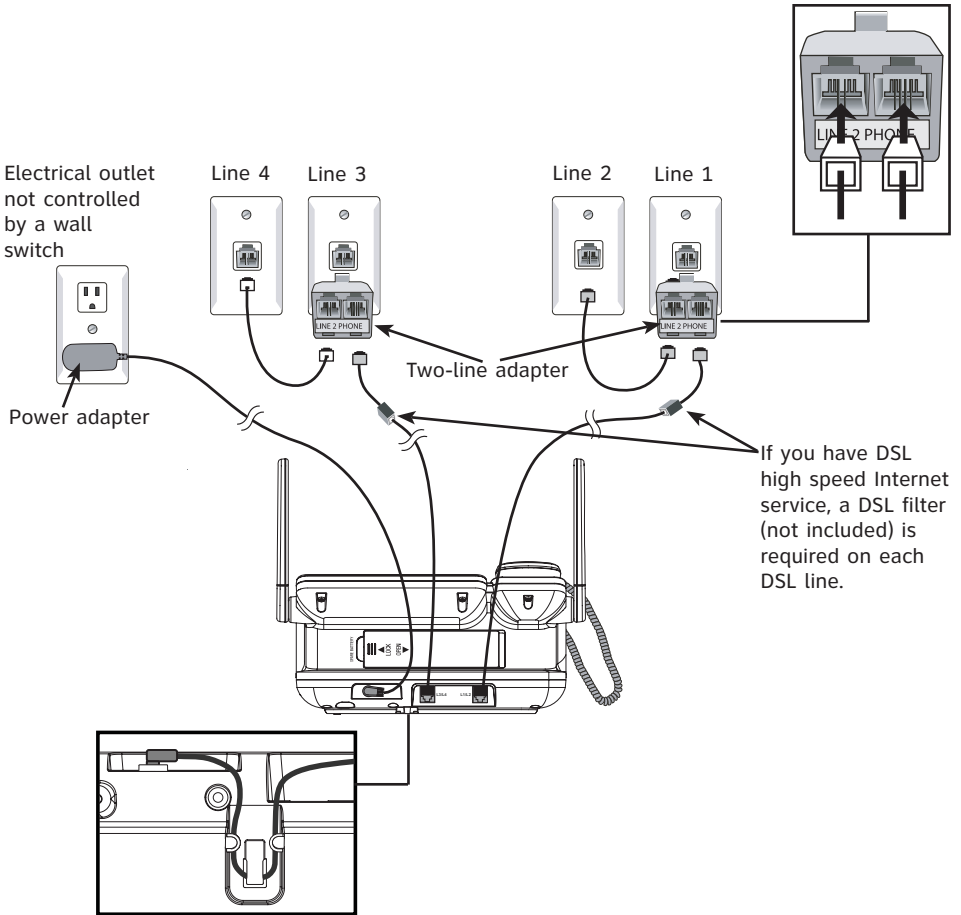

Option 2: To connect four one-line wall jacks



## NOTES:

1. If you have three one-line wall jacks, you need a two-line splitter for two of the lines.
2. The long cords supplied with the phone are four-conductor cords.
3. To order a two-line adapter, visit our website at [www.telephones.att.com](http://www.telephones.att.com), or call **1 (800) 222-3111**. In Canada dial **1 (866) 288-4268**.

## Optional backup battery installation

Install four AA batteries (purchased separately) to use some features of this telephone in the event of a power failure. If power fails with working batteries installed, all the lines of this phone will work only with the corded handset. You can answer calls, and dial calls using the dial pad and the one touch or redial features. No other features will work until AC power is restored.

Install the telephone base as shown below.

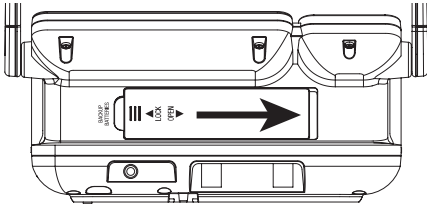

**Step 1** Open the backup battery compartment cover

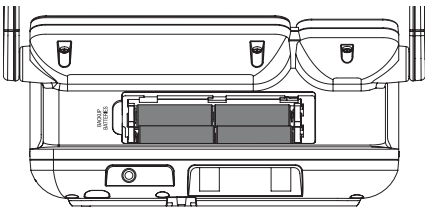
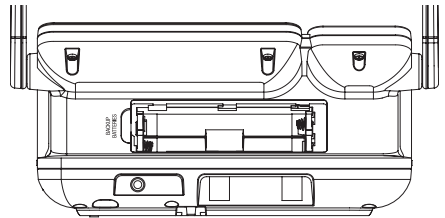

**Step 2** Place the batteries in the compartment following the polarity label +/- .

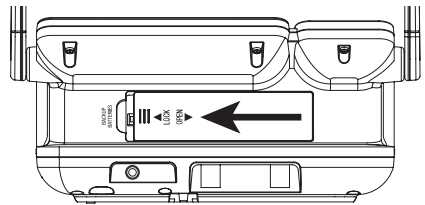

**Step 3** Align the cover flat against the battery compartment, then slide it to the left until it clicks into place to lock the cover.



### NOTES:

1. Use disposable AA alkaline batteries only. Do not use rechargeable batteries.
2. When there is AC power and there is no spare battery or the spare battery is low, the screen shows **LOW BATT**.

## Add and register handsets

Your telephone can have up to ten cordless handsets. You can add new handsets (model SB67108, sold separately) to the SB67118 at any time, but each new handset must be registered with the telephone base before use. Each handset must be registered separately.

The handset provided with your SB67118 is automatically registered as handset 1. Additional handsets will be assigned numbers in the order they are registered (handset 2 to 10). You can register a maximum of ten handsets.

Handsets purchased separately need to be registered to the telephone base before use. When first purchased, all optional accessory handsets will show **Place handset in cradle and press INT on base for 4 seconds to register handset** on the screen. You might need to charge the new handsets a minimum of five minutes before registering to the telephone base (see **Battery installation and charging** in the SB67108 cordless handset manual).

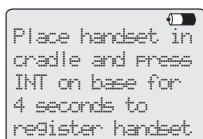

Place handset in cradle and press INT on base for 4 seconds to register handset

### To register a handset to your telephone base

1. Place the unregistered handset into the charger cradle.
2. On the telephone base, press and hold **INT** button for about four seconds (until the red light below the button turns on) and then release the button. The screen of the telephone base shows **Handset registering** and it takes about **10** seconds to complete the registration. The handset shows **Handset registered** and beeps when the registration is successful.

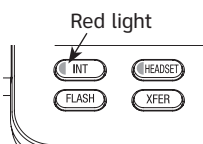

**-OR-**

1. Place the unregistered handset into the charger cradle.
2. On the telephone base, press **MENU/ENTER**, then scroll down to **Registration**.
3. Press **MENU/ENTER** again to browse the selections, scroll to **HS registration**.
4. Press **MENU/ENTER**. The screen of the telephone base shows **Handset registering** and it takes about 10 seconds to complete the registration. The handset shows **Handset registered** and beeps when the registration is successful.

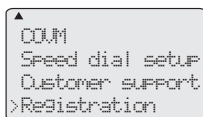

COUM  
Speed dial setup  
Customer support  
>Registration

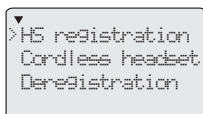

>HS registration  
Cordless headset  
Deregistration

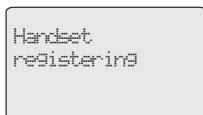

Handset  
registering

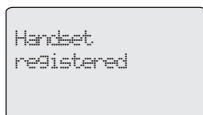

Handset  
registered

## Replace a handset



**NOTE:** If the registration is not successful, the display shows **Place handset in cradle and press INT on base for 4 seconds to register handset.** To reset the handset, remove the handset from the charger and place it back in. Try the registration process again.

### **You may need to de-register your handsets if**

---

You have ten registered handsets and either need to replace a handset or add a cordless headset (AT&T model TL7600, TL7610 or TL7611), sold separately.

**-OR-**

You wish to change the handset numbers of your registered handsets.

You must first de-register ALL the handsets, and then re-register each handset you wish to use.

## De-register all handsets

**Please read carefully through all the instructions on this page before beginning the de-registration process. De-registering a cordless handset removes all the data saved on the handset and the settings on the telephone base for the selected cordless handset.**

This process de-registers all cordless handsets and any cordless headset registered to the telephone base. Please make sure the telephone system is not in use before de-registration.

1. On the telephone base, press **MENU/ENTER**, then scroll down to **Registration**.
2. Press **MENU/ENTER** again, then scroll to **Deregistration**.
3. Press **MENU/ENTER**. The screen of the telephone base shows **Deregister all handsets? <=No Yes=>**. Press **◀** or **▶** on the Navkeys to exit or continue the deregistration.
4. The screen of the telephone base shows **Deregistering**, and it takes about 10 seconds to complete the deregistration. The screen shows **All handsets deregistered** and beeps when the deregistration is successful.

```

^
COMM
Speed dial setup
Customer support
>Registration
  
```

```

^
HS registration
Cordless headset
>Deregistration
  
```

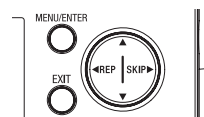

```

Deregister all
handsets?
<=No Yes=>
  
```

```

Deregistering
  
```

```

All handsets
deregistered
  
```



### NOTES:

1. If the de-registration process is not successful, you might need to reset the system and try again. To reset: you can press **EXIT** on the telephone base. You can also reset the telephone base by unplugging the power from the telephone base and plugging it back in.
2. You cannot de-register the handsets if any system handset is in use.
3. To re-register a cordless handset, refer to the registration information on page XX.

## Optional cordless headset (purchased separately)

### To add a DECT 6.0 cordless headset to the system

---

The cordless headset must have a charged battery and be de-registered before you can register it to the SB67118. Make sure the headset battery is properly installed. Place the headset in the headset charger and note the color of the **ON/OFF** button. If the button flashes a blue and orange light twice every five seconds, the headset is unregistered. If the button shows a constant blue or orange light, the headset is registered. You will need to de-register the headset before you can register it to the SB67118 (see the de-registration instructions in the TL7610/7611 DECT 6.0 cordless headset User's manual). To view the TL7610/7611/7600 model manual, visit our website at [www.telephones.att.com](http://www.telephones.att.com), or call **1 (800) 222-3111**. In Canada dial **1 (866) 288-4268**.

- To register the DECT headset to the telephone base
1. Place the headset in the headset charger and allow it to charge for at least five minutes before beginning registration.
  2. On the telephone base, press **MENU/ENTER**, then scroll down to **Registration**.
  3. Press **MENU/ENTER** again to browse the selections, scroll to **Cordless headset**.
  4. Press **MENU/ENTER**. The screen of the telephone base shows **Cordless headset registering** and it takes about 10 seconds to complete the registration.
  5. The screen of the telephone base shows **Cordless headset registered** and beeps when the registration is successful.

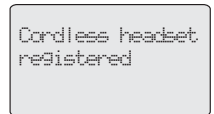
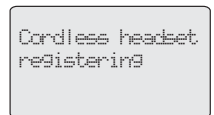
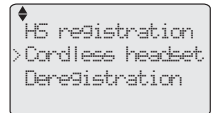
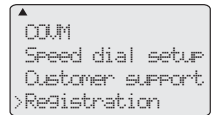
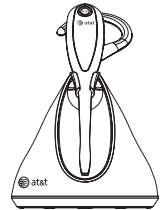

To verify registration was successful, press the headset **ON/OFF** button and check for a dial tone.

If the registration is not successful, the **ON/OFF** light on the headset flashes twice every five seconds. To reset the headset, remove the headset from the headset charger and try the registration process again.

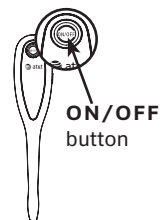



## Optional corded headset (purchased separately)

You can use this phone hands-free when you install any industry-standard two-band 2.5mm corded headset or AT&T compatible DECT 6.0 cordless headset. Purchase the headsets separately. For best results, use an AT&T 2.5 mm corded headset, or AT&T TL7610/7611/7600 DECT 6.0 cordless headset. To purchase a headset, visit our website at [www.telephones.att.com](http://www.telephones.att.com), or call **1 (800) 222-3111**. In Canada dial **1 (866) 288-4268**.

### To add a corded headset to the telephone base

---

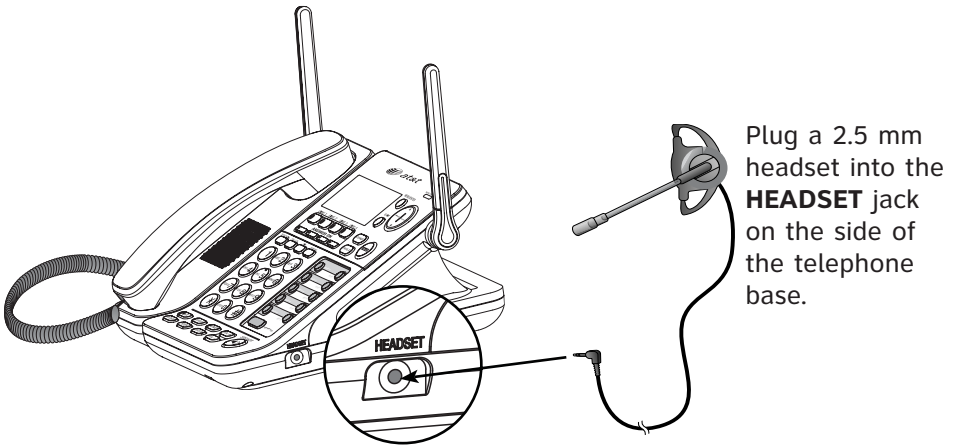

Side view of the telephone base

- To make a call:
  1. Press **HEADSET** on the telephone base (if you have a corded or cordless headset is connected to the telephone base).
  2. Wait for a dial tone, then dial the number.
- To answer a call, press **HEADSET**.
- To hang up, press **HEADSET**.

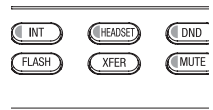

**i** **NOTE:** If you have corded and cordless headsets connected to your telephone base, then the **HEADSET** key controls the corded headset. If you have only a cordless headset connected, then the **HEADSET** key controls the cordless headset.

# Telephone base setup

## Menu settings

Use the menus to change the telephone base settings.

1. Press **MENU/ENTER** when in idle mode (when the phone is not in use) to enter the main menu.
2. Press **▲** or **▼** to scroll to the feature to be changed. The > symbol indicates the menu item.
3. Press **MENU/ENTER** to select the menu item.
4. Press **EXIT** to exit setup without making changes.

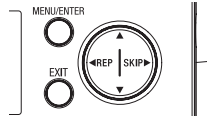

**i NOTE:** Press **EXIT** to cancel an operation, exit the menu display, or return to idle mode.

## Ringer volume

You can set the ring volume level (1-5), or turn the ringer off. When the ringer is off,  appears on the telephone base screen.

1. When the telephone is idle, press **MENU/ENTER**.
2. Press **▲** or **▼** to scroll to **Ringer setting**. Press **MENU/ENTER**.
3. Press **MENU/ENTER** again to select **Ringer volume**.
4. Press **◀** or **▶** or the **VOL+** or **VOL-** keys on the telephone base to adjust the ringer volume.
5. Press **MENU/ENTER** to save the setting and return to the previous menu. There is a confirmation tone. To exit without making changes, press **EXIT**.

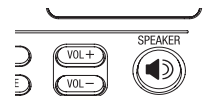
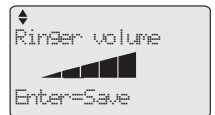
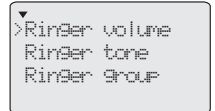
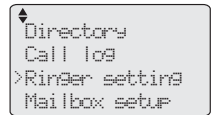

**i NOTE:** When the ringer is off,  stays on the telephone base screen displays.

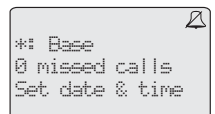

## Telephone base setup

### Volume control (general settings)

You can independently set the listening volume of each of the three listening options (corded handset, speakerphone and corded headset). While using each, press the **VOL+** and **VOL-** keys to adjust the listening volume.

While using the volume control, you will hear a triple beep when you reach the minimum or maximum level.

The SB67118 telephone base remembers the volume setting for each listening option.

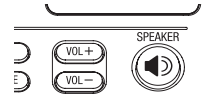

### Ringer tone

You can choose one of the seven ringer tones for incoming calls. You can choose different ringer types for different lines so you can easily identify which line is ringing.

1. When the telephone is idle, press **MENU/ENTER**.
2. Press **▲** or **▼** to scroll to **Ringer setting**. Press **MENU/ENTER**.
3. Press **▲** or **▼** to scroll to **Ringer tone**. Press **MENU/ENTER**.
4. Press **◀** or **▶** to select the desired line ( **L1, L2, L3, L4** ).
5. Press **▲** or **▼** to select the desired ringer tone.
6. To move to other line, press **◀** or **▶**.
7. Press **MENU/ENTER** to save the setting and return to the previous menu. There is a confirmation tone. To exit without making changes, press **EXIT**.

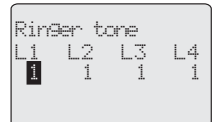
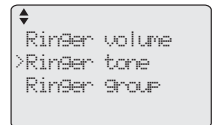
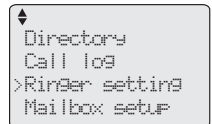

# Telephone base setup

## Ring group

You can specify which extensions receive incoming calls. By default, all extensions and the telephone base receive incoming calls. You can block some extensions from receiving calls, however, they can still be used to place outgoing calls.

1. When the telephone is idle, press **MENU/ENTER**.
2. Press **▲** or **▼** to scroll to **Ring setting**. Press **MENU/ENTER**.
3. Press **▲** or **▼** to scroll to **Ring group**. Press **MENU/ENTER**.
4. Press **◀** or **▶** to select the desired line ( **L1, L2, L3, L4** ) while **Ring group** flashes.
5. Press **▲** or **▼**, then press the extension number on the dial pad (**\*,1,2,3,4,5,6,7,8,9,0**) that you want to delete from the ring group, or press the number again to add it up to the group.
6. Press **MENU/ENTER** to save the setting and return to the previous menu. There is a confirmation tone. To exit without making changes, press **EXIT**.

```
Directory
Call log
>Ring setting
Mailbox setup
```

```
▲
Ringer volume
Ringer tone
>Ringer group
```

```
Ring group: L3
Extension number:
*1234567890
<>
```

```
Ring group: L3
Extension number:
*1-3-56-8-0
Enter=Save
```



**NOTE:** \* stands for the telephone base; 0 stands for extension 10.

## LCD contrast

You can adjust the screen contrast to one of six levels to optimize readability in different lighting conditions.

1. When the telephone is idle, press **MENU/ENTER**.
2. Press **▲** or **▼** to scroll to **Base setup**. Press **MENU/ENTER**.
3. Press **MENU/ENTER** again to select **LCD contrast**.
4. Press **▲** or **▼** to scroll to the screen contrast level. The screen display temporarily fades away as you press **▼** and reappears as you press **▲**.
5. Press **MENU/ENTER** to save the setting and return to the previous menu. There is a confirmation tone. To exit without making changes, press **EXIT**.

```
Call log
Ringer setting
Mailbox setup
>Base setup
```

```
>LCD contrast
Key tone
Language
Line selection
```

```
▲
LCD contrast
LOW | | | | | | | | | |
Enter=Save
```

## Telephone base setup

### Key tone

You can turn the Key tone on and off. The telephone base is factory programmed to beep with each key press. If you turn off the **Key tone**, there will be no beeps when keys are pressed.

To turn the key tone on and off:

1. When the telephone is idle, press **MENU/ENTER**.
2. Press ▲ or ▼ to scroll to **Base setup**. Press **MENU/ENTER**.
3. Press ▲ or ▼ to scroll to **Key tone**. Press **MENU/ENTER**.
4. Press ▲ or ▼ to scroll to **On** or **Off**.
5. Press **MENU/ENTER** to save the setting and return to the previous menu. There is a confirmation tone. To exit without making changes, press **EXIT**.

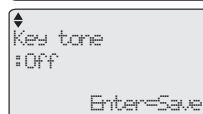
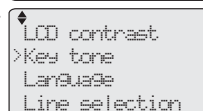
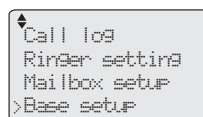

### Language

You can change the display language that is used in all menus and screen displays. Set the display language separately on the telephone base and each extension separately. This telephone comes factory set for English displays.

To change the display language for the telephone base:

1. When the telephone is idle, press **MENU/ENTER**.
2. Press ▲ or ▼ to scroll to **Base setup**. Press **MENU/ENTER**.
3. Press ▲ or ▼ to scroll to **Language**. Press **MENU/ENTER**.
4. Press ▲ or ▼ to scroll to a language.
5. Press **MENU/ENTER** again to save the setting and return to the previous menu. There is a confirmation tone. To exit without making changes, press **EXIT**.

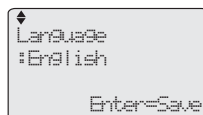
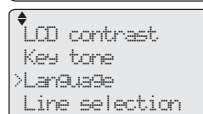
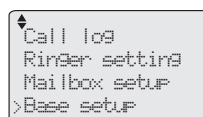

### Line selection

You can set the specific telephone line for your telephone base to make outgoing calls. This telephone comes factory set for **Auto** selectable line, which chooses the most available line for making a call.

1. When the telephone is idle, press **MENU/ENTER**.
2. Press ▲ or ▼ to scroll to **Base setup**. Press **MENU/ENTER**.

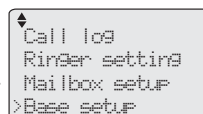

# Telephone base setup

3. Press ▲ or ▼ to scroll to **Line selection**. Press **MENU/ENTER**.
4. Press ▲ or ▼ to scroll to the desired line, **Auto**, **L1**, **L2**, **L3** or **L4**, that you want to set as default line for making outgoing calls.
5. Press **MENU/ENTER** to save the setting and return to the previous menu. There is a confirmation tone. To exit without making changes, press **EXIT**.

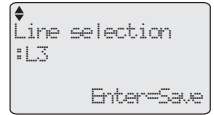
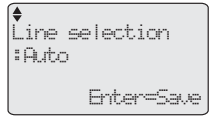
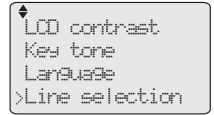

## Set line mode

For the system to behave properly, it needs to be set for:

a) **PBX** lines, which are typically business telephone systems that require you to dial **8** or **9** to get an outside line.

**-OR-**

b) **CO** lines, which are standard residential telephone lines. This telephone comes factory set for **PBX** lines.

You can set each line, individually to either **PBX** or **CO**.

1. When the telephone is idle, press **MENU/ENTER**.
2. Press ▲ or ▼ to scroll to **Base setup**. Press **MENU/ENTER**.
3. Press ▲ or ▼ to scroll to **Set line mode**. Press **MENU/ENTER**.
4. Press ▲ or ▼ to scroll to a desired line, **L1**, **L2**, **L3** or **L4**.
5. Press ◀ or ▶ to change the highlighted line mode, **PBX** or **CO**.
6. Press ▲ or ▼ to move to another line.
7. Press **MENU/ENTER** to save the setting and return to the previous menu. There is a confirmation tone. To exit without making changes, press **EXIT**.

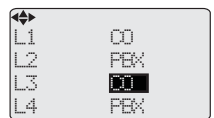
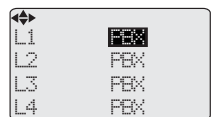
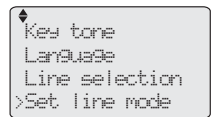
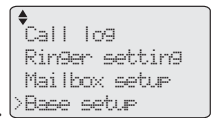

**NOTE:** If the line icon on the base screen display does not reflect the line status, try another line mode.

## Telephone base setup

### Area codes

You can program this system to recognize one home area code and up to four local area codes. This feature makes it easy for you to place a call from the caller ID log.

If you dial 7 digits to make a local call (no area code required), enter your area code into the telephone as the home area code. When you receive a call from within your home area code, the caller ID history only displays the seven digits of the telephone number, and when you dial from the call log, only seven digits are dialed.

If you must dial 10 digits (the area code and telephone number) for calls within your own home area code, enter **000** for the home area code and enter your area code as a local area code. Then, if you receive a call from within your area code, the screen displays the 10 digits of the telephone number, and when you dial from the call log, only ten digits will be dialed.

If you must also dial 10-digit for other nearby area codes, enter those area codes as local area codes.

1. When the telephone is idle, press **MENU/ENTER**.
2. Press **▲** or **▼** to scroll to **Base setup**. Press **MENU/ENTER**.
3. Press **▲** or **▼** to scroll to **Area codes**. Press **MENU/ENTER**.
4. Press **▲** or **▼** to scroll to **Home area** or **Local area 1-4**. Press **MENU/ENTER** to edit it.
5. Use the dial pad keys to enter a 3-digit area code. Enter **000** for your home area code if you never dial 7-digit numbers. Press **◀** or **▶** to scroll to the digit you want to edit, or press **REMOVE** to delete digits while entering.
6. Press **MENU/ENTER** to save the setting and return to the previous menu. There is a confirmation tone. To exit without making changes, press **EXIT**.

```

Call log
Ringer setting
Mailbox setup
>Base setup
  
```

```

Language
Line selection
Set line mode
>Area codes
  
```

```

>Home area
Local area 1
Local area 2
Local area 3
  
```

```

Home area
█
Enter=Save
  
```

```

Local area 1
001█
Enter=Save
  
```

## Telephone base setup

### Area codes

You can program this system to recognize one home area code and up to four local area codes. This feature makes it easy for you to place a call from the caller ID log.

If you dial 7 digits to make a local call (no area code required), enter your area code into the telephone as the home area code. When you receive a call from within your home area code, the caller ID history only displays the seven digits of the telephone number, and when you dial from the call log, only seven digits are dialed.

If you must dial 10 digits (the area code and telephone number) for calls within your own home area code, enter **000** for the home area code and enter your area code as a local area code. Then, if you receive a call from within your area code, the screen displays the 10 digits of the telephone number, and when you dial from the call log, only ten digits will be dialed.

If you must also dial 10-digit for other nearby area codes, enter those area codes as local area codes.

1. When the telephone is idle, press **MENU/ENTER**.
2. Press **▲** or **▼** to scroll to **Base setup**. Press **MENU/ENTER**.
3. Press **▲** or **▼** to scroll to **Area codes**. Press **MENU/ENTER**.
4. Press **▲** or **▼** to scroll to **Home area** or **Local area 1-4**. Press **MENU/ENTER** to edit it.
5. Use the dial pad keys to enter a 3-digit area code. Enter **000** for your home area code if you never dial 7-digit numbers. Press **◀** or **▶** to scroll to the digit you want to edit, or press **REMOVE** to delete digits while entering.
6. Press **MENU/ENTER** to save the setting and return to the previous menu. There is a confirmation tone. To exit without making changes, press **EXIT**.

```

Call log
Ringer setting
Mailbox setup
>Base setup
  
```

```

Language
Line selection
Set line mode
>Area codes
  
```

```

>Home area
Local area 1
Local area 2
Local area 3
  
```

```

Home area
█
Enter=Save
  
```

```

Local area 1
001█
Enter=Save
  
```



# Telephone base setup

## Hold reminder

You can have silence or to play a beep tone every 30 seconds when there is a call on hold.

1. When the telephone is idle, press **MENU/ENTER**.
2. Press **▲** or **▼** to scroll to **Base setup**. Press **MENU/ENTER**.
3. Press **▲** or **▼** to scroll to **Hold reminder**. Press **MENU/ENTER**.
4. Press **▲** or **▼** to scroll to **On** or **Off**.
5. Press **MENU/ENTER** to save the setting and return to the previous menu. There is a confirmation tone. To exit without making changes, press **EXIT**.

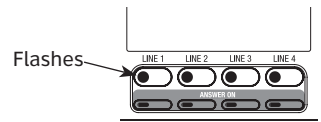
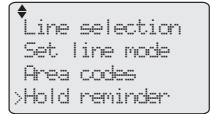

## Time adjustment

The answering system displays the day and time of the message while to playing it. Before using the answering system, set the date and time as follows. If you subscribe to caller ID service, the day, month and time are set automatically with each incoming call. The year must be set so that the day of the week can be calculated from the caller ID information.

Follow the steps below to set the month, day, year and time.

1. When the telephone is idle, press **MENU/ENTER**.
2. Press **▲** or **▼** to scroll to **Base setup**. Press **MENU/ENTER**.
3. Press **▲** or **▼** to scroll to **Time adjustment**. Press **MENU/ENTER**.
4. Using the dial pad, enter the date. Press **◀** or **▶** to scroll to the item you want to edit, and press the dial pad keys to enter the correct digit.
5. Press **▼** to move to the time editing.
6. Press **▲** or **▼** to select the **AM** or **PM**.
7. Press **◀** or **▶** to scroll to the item you want to edit, and press to enter the correct digit.

**-OR-**

Press **◀** to move back to the date editing.

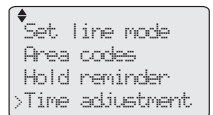

Wrong setting

## Telephone base setup

8. Press **MENU/ENTER** to save the setting and return to the previous menu. There is a confirmation tone. To exit without making changes, press **EXIT**.



### NOTES:

1. The time format is in 12-hour clock format. If you set an invalid time, you hear an error tone while pressing ENTER to save the setup. The error tone means the setting cannot be saved. You need to correct the time entry to continue the set up process..
2. If the date and time are not set when a message is recorded, the system does not display date and time on the screen while playing messages..

## Music on hold (MOH)

---

You can turn MOH on or off. When MOH is On, the system plays either pre-recorded music or your own music or message to people whom you have put on hold.

You have two options for creating your own recording (up to three minutes) to play as music on hold. This recording replaces the pre-recorded music. Once you record your own, you cannot go back to the pre-recorded music. You can use the provided audio cable to copy a recording from an audio device, or you can record a message using the telephone handset.

### • Turning MOH on or off

1. When the telephone is idle, press **MENU/ENTER**.
2. Press **▲** or **▼** to scroll to **Base setup**. Press **MENU/ENTER**.
3. Press **▲** or **▼** to scroll to **Music on hold**. Press **MENU/ENTER**.
4. Press **MENU/ENTER** again to select **Music on/off**.
5. Press **▲** or **▼** to select **On** or **Off**.
6. Press **MENU/ENTER** to save the setting and return to the previous menu. There is a confirmation tone. To exit without making changes, press **EXIT**.

### • Reviewing the recording

1. When the telephone is idle, press **MENU/ENTER**.
2. Press **▲** or **▼** to scroll to **Base setup**. Press **MENU/ENTER**.

```
Call log
Ringer setting
Mailbox setup
>Base setup
```

```
>Music on/off
Preview music
Record new music
```

```
Music on hold
=On

Enter=Save
```

## Telephone base setup

3. Press ▲ or ▼ to scroll to **Music on hold**. Press **MENU/ENTER**.
4. Press ▲ or ▼ to scroll to **Preview music**. Press **MENU/ENTER** to hear the current recording.
5. Press ◀ to return to the previous menu.

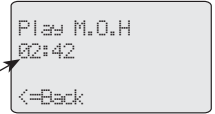
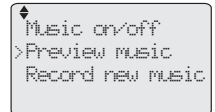

Elapsed time

- **Copying recorded music or message**

1. When the telephone is idle, press **MENU/ENTER**.
2. Press or to scroll to **Base setup**. Press **MENU/ENTER**.
3. Press or to scroll to **Music on hold**. Press **MENU/ENTER**.
4. Press or to scroll to **Record new music**. Press **MENU/ENTER**.
5. When you are ready, start playing the music on your audio device and press **MENU/ENTER** to start recording. A timer appears on the screen and starts counting.
6. Press **MENU/ENTER** to stop recording. Then the display returns to the previous menu. To exit without making changes, press **EXIT**.

- **Recording music or message using the handset**

1. When the telephone is idle, press **MENU/ENTER**.
2. Press or to scroll to **Base setup**. Press **MENU/ENTER**.
3. Press or to scroll to **Music on hold**. Press **MENU/ENTER**.
4. Press or to scroll to **Record new music**. Press **MENU/ENTER**.
5. Pick up the handset. When you are ready, press **MENU/ENTER** to start recording. A timer appears on the screen and starts counting.
6. Press **MENU/ENTER** to stop recording. Then the display returns to the previous menu. To exit without making changes, press **EXIT**.

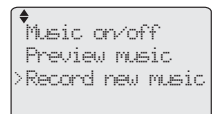

### **NOTES:**

1. Do not lift the corded handset for recording until you enter the Record new music menu.
2. If there is silence detected for six seconds while recording, the screen display automatically returns to the upper level menu. That means the recording was unsuccessful. The previously recorded music or message will play when calls are on hold until you successfully record new music or a message.
2. After three minutes, the base stops recording, but the recording is saved. The screen returns to the previous menu. The new recording replaces the pre-recorded music to be played when calls are on hold.

## Auto attendant setup (for answering system)

You can set up the auto attendant to answer outside calls, provide callers with company directories and record voice messages for each telephone line. You can use a pre-recorded announcement or record your own; you can record up to five announcements of up to two minutes each by the mouthpiece of the corded handset.

### Turn on the auto attendant

1. When the telephone is idle, press the **ANSWER ON** key for the line you want to set up.
2. Press **▲** or **▼** to scroll to **Ans->Auto att.**  
Press **MENU/ENTER**. The Auto attendant is on and the current auto attendant announcement plays. The screen displays **Auto Attendant ON Play announcement**, and then the idle screen appears.

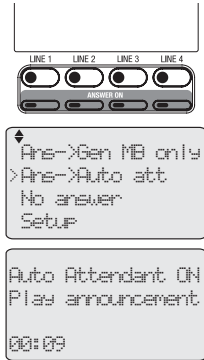

**NOTE:** While previewing the announcement, press **VOL+** or **VOL-** to adjust the volume. If you do not want to hear the announcement, press **EXIT**, the setting is saved.

### Number of rings

You can set the number of times the phone rings before the Auto Attendant answers. The number of rings can be **2, 3, 4, 5, 6** or **7**.

1. When the telephone is idle, press **ANSWER ON** for the desired line.
2. Press **▲** or **▼** to scroll to **Setup**. Press **MENU/ENTER**.
3. Press **▲** or **▼** to scroll to **Auto attendant**. Press **MENU/ENTER**.
4. Press **MENU/ENTER** again to select **Number of rings**.
5. Press **▲** or **▼** to select a number.
6. Press **MENU/ENTER** to save the setting and return to the previous menu. There is a confirmation tone. To exit without making changes, press **EXIT**.

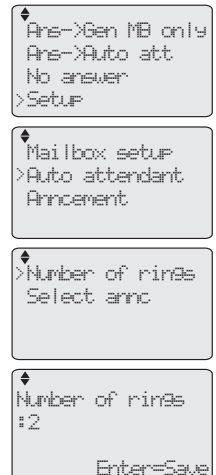

# Auto attendant setup (for answering system)

## Record announcement

---

You can record up to five new announcements so that you can have different announcements for different lines. Each announcement can be up to two minutes.

1. When the telephone is idle, press **ANSWER ON** for the desired line.
2. Press **▲** or **▼** to scroll to **Setup**. Press **MENU/ENTER**.
3. Press **▲** or **▼** to scroll to **Announcement**. Press **MENU/ENTER**.
4. Press **▲** or **▼** to scroll to one of the announcements from, **Annnc 1** through **Annnc 5**. If no message has been recorded, **(none)** also appears. Press **MENU/ENTER**.
5. Press **MENU/ENTER** to start recording. The timer starts counting.
6. Press **MENU/ENTER** to stop recording. The timer stops and the recorded announcement automatically plays back.
7. Press **2** to save the setting and return to the previous menu, or press **1** to re-record that announcement..

```
Mailbox setup
Auto attendant
>Announcement
```

```
>Annnc 1 (none)
Annnc 2 (none)
Annnc 3 (none)
```

```
Record annnc 1

Enter=Save
```

```
Record annnc 1
00:11

Enter=Stop
```

```
Play annnc 1
00:03

1=Change 2=OK
```

**-OR-**

To exit without making changes, press **EXIT**.



**NOTE:** Once there is a message, **(none)** disappears after the message **Annnc 1** through **Annnc 5**.

```
>Annnc 1
Annnc 2 (none)
Annnc 3 (none)
```

## Select announcement

---

You can select an announcement for your independent auto attendant from the list of announcements.

1. When the telephone is idle, press **ANSWER ON** for the desired line.
2. Press **▲** or **▼** to scroll to **Setup**. Press **MENU/ENTER**.
3. Press **▲** or **▼** to scroll to **Auto attendant**. Press **MENU/ENTER**.

```
Mailbox setup
>Auto attendant
Announcement
```

## Auto attendant setup (for answering system)

4. Press ▲ or ▼ to scroll to **Select annc.**  
Press **MENU/ENTER**.
5. Press ▲ or ▼ to scroll to an announcement.
6. Press **MENU/ENTER** to save the setting and return to the previous menu. There is a confirmation tone. To exit without making changes, press **EXIT**.

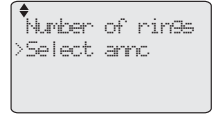

**NOTE:** The auto attendant and the private mailboxes share the same list of announcements. Make sure to preview to select a correct announcement before setting.

### Turn off the auto attendant

1. When the telephone is idle, press **ANSWER ON** for the desired line.
2. Press ▲ or ▼ to scroll to **No answer**. Press **MENU/ENTER** to turn off the auto attendant feature for that line.

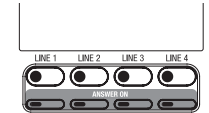
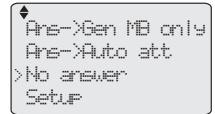

**NOTE:** You cannot record an announcement when the phone system is out of space. You will hear "Sorry, there is no space for recording." Please refer to **Remaining space** on page X.

# Mailbox setup (for answering system)

You set each telephone line mailbox separately.

## Turn on the mailbox

1. When the telephone is idle, press **ANSWER ON** for the desired line.
2. Press **▲** or **▼** to scroll to **Ans->Gen MB only**. Press **MENU/ENTER**.

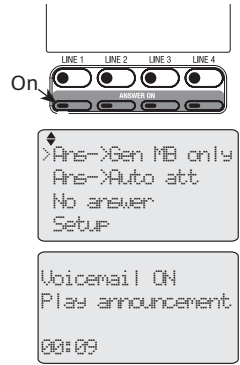

The **ANSWER ON** indicator lights. The current mailbox announcement plays. The screen displays **Voicemail ON Play announcement**, and then it returns to the idle screen.

**-OR-**

To exit without making changes, press **EXIT**.



**NOTE:** While previewing the announcement, you can adjust the volume by pressing **VOL+** or **VOL-**. If you do not want to hear the announcement, press **EXIT**, the setting is saved.

## Number of rings

You can set the number of times the phone rings before the Mailbox answers. The number of rings can be **2, 3, 4, 5, 6** or **7**. You can also select **Toll saver**, which is explained below. Unless you change it, the answering system answers an incoming call after four rings.

1. When the telephone is idle, press **ANSWER ON** for the desired line.
2. Press **▲** or **▼** to scroll to **Setup**. Press **MENU/ENTER**.
3. Press **MENU/ENTER** again to select **Mailbox setup**.
4. Press **MENU/ENTER** again to select **Number of rings**.
5. Press **▲** or **▼** to scroll to a number or toll saver.

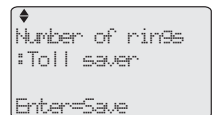
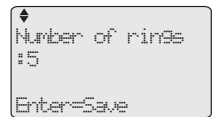
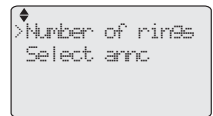
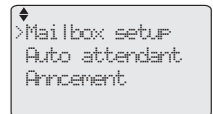

- **Toll saver** - the answering system answers a call after two rings when there are new messages, and after four rings when there are no new messages. This enables you to check for new messages without paying for a toll call.

6. Press **MENU/ENTER** to save the setting and return to the previous menu. There is a confirmation tone. To exit without making changes, press **EXIT**.

## Mailbox setup (for answering system)

### Select announcement

---

You can select an announcement for your independent mailbox from the list of announcements.

1. When the telephone is idle, press **ANSWER ON** for the desired line.
2. Press **▲** or **▼** to scroll to **Setup**. Press **MENU/ENTER**.
3. Press **MENU/ENTER** again to select **Mailbox setup**.
4. Press **▲** or **▼** to scroll to **Select annc**. Press **MENU/ENTER**.
5. Press **▲** or **▼** to scroll to an announcement.
6. Press **MENU/ENTER** to save the setting and return to the previous menu. There is a confirmation tone. To exit without making changes, press **EXIT**.

```
▼Mailbox setup
  Auto attendant
  Announcement
```

```
◆
  Number of rings
  >Select annc
```

```
◆
  Select annc
  #Prerecord
                                     Enter=Save
```

```
◆
  Select annc
  #Annc 1
                                     Enter=Save
```

**i** **NOTE:** The auto attendant and the mailbox share the same list of announcements. Preview the announcements to select the correct announcement before setting.

### Record announcement

---

You can record up to five new announcements so that you can have different announcements for different lines. Each announcement can be up to two minutes. . Please see **Record announcement (auto attendant)** on page 25.

**i** **NOTE:** You cannot record an announcement when the phone system is out of space. You will hear "Sorry, there is no space for recording". Please refer to **Remaining space** on page X.

### Turn off the mailbox

---

1. When the telephone is idle, press **ANSWER ON** for the desired line.
2. Press **▲** or **▼** to scroll to **No answer**. Press **MENU/ENTER**.

```
◆
  Ans->Gen MB only
  Ans->Auto att
  >No answer
  Setup
```

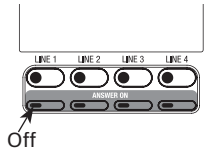



## Mailbox setup (for general mailbox)

### Set access code (Remote code)

---

You can enter a four-digit number (**0000-9999**) to allow remote access to your general mailbox from any touch-tone telephone. Unless you change it, the remote access code is **0000**.

1. When the telephone is idle, press **MENU/ENTER**.
2. Press **▲** or **▼** to scroll to **Mailbox setup**. Press **MENU/ENTER**.
3. Press **MENU/ENTER** again to select **Set access code**.
4. Use the dial pad to enter a four-digit number. Use **REMOVE** to delete a digit.
5. Press **MENU/ENTER** to save the setting and return to the previous menu. There is a confirmation tone. To exit without making changes, press **EXIT**.

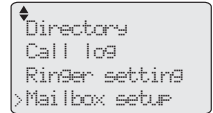

Directory  
Call log  
Ringer setting  
>Mailbox setup

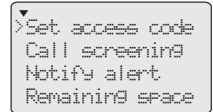

>Set access code  
Call screening  
Notify alert  
Remaining space



Enter mailbox  
access code:  
0000  
Enter=Save



Enter mailbox  
access code:  
9999  
Enter=Save



#### NOTES:

1. The access code must have four digits.
2. You will hear an error tone if you enter an access code that is already being used.

### Call screening

---

You can choose whether incoming messages can be heard over the speaker when they are being recorded. If you turn call screening on, you hear the incoming private message on your telephone when a call comes in.

If more than one incoming messages from different phone lines comes at the same time, only the first incoming message is monitored. While monitoring message recording, you can answer the call by lifting the corded handset or by pressing **📞 SPEAKER**.

You can press **VOL+** or **VOL-** to adjust the volume while listening to the message recording. If you want to stop the message recording, press **MUTE** on the base to temporarily disable the call screening.

Follow the steps below to set call screening feature on or off:

1. When the telephone is idle, press **MENU/ENTER**.
2. Press **▲** or **▼** to scroll to **Mailbox setup**. Press **MENU/ENTER**.
3. Press **▲** or **▼** to scroll to **Call screening**.

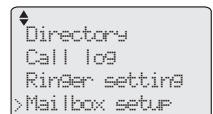

Directory  
Call log  
Ringer setting  
>Mailbox setup

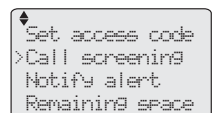

>Set access code  
>Call screening  
Notify alert  
Remaining space

## Mailbox setup (for general mailbox)

Press **MENU/ENTER**.

4. Press **▲** or **▼** to highlight **On** or **Off**.
5. Press **MENU/ENTER** to save the setting and return to the previous menu. There is a confirmation tone. To exit without making changes, press **EXIT**.

```
Call screening
:On
Enter=Save
```

```
Call screening
:Off
Enter=Save
```

### Notify alert

---

You can receive notification calls to your cell phone or paging device after each new phone call message has been recorded to the general mailbox. You can remotely access the message from a touch-tone telephone (see page XX for instructions). To receive notification calls, you must save your phone number on the telephone base, and then set the system to call that number after it finishes recording a message.

1. When the telephone is idle, press **MENU/ENTER**.
2. Press **▲** or **▼** to scroll to **Mailbox setup**. Press **MENU/ENTER**.
3. Press **▲** or **▼** to scroll to **Notify alert**. Press **MENU/ENTER**.

```
Set access code
Call screening
>Notify alert
Remaining space
```

### Set alert number

1. Press **MENU/ENTER** again to select **Alert number**. Use the dial pad to enter the number (Up to 33 digits) of the phone you want to be notified. Press **REMOVE** to delete the last digit.
2. Press **MENU/ENTER** to save the setting and return to the previous menu. There is a confirmation tone. Press **EXIT** to exit setup without making changes.

```
>Alert number
Alert on/off
Alert call #.. #
```

```
Enter alert #:
2345678█
Enter=Save
```

### Turn alert on or off

1. Press **▲** or **▼** to scroll to **Alert on/off**. Press **MENU/ENTER**.
2. Press **▲** or **▼** to scroll to **On** or **Off**.
3. Press **MENU/ENTER** to save the setting and return to the previous menu. There is a confirmation tone. To exit without making changes, press **EXIT**.

```
Alert number
>Alert on/off
Alert call #.. #
```

```
Alert on/off
:On
Enter=Save
```



**NOTE:** If you turn on **Notify alert** before you enter the **Alert number**, "Please set the alert number" appears on the screen.

# Mailbox setup (for general mailbox)

## Confirm the alert call

You can confirm whether the system can successfully call the alert number that you entered above.

1. When the telephone is idle, press **MENU/ENTER**.
2. Press **▲** or **▼** to scroll to **Mailbox setup**. Press **MENU/ENTER**.
3. Press **▲** or **▼** to scroll to **Alert call #..#**. Press **MENU/ENTER**.
4. The screen displays **Press SPK to confirm the alert call**.
5. Press **🔊 SPEAKER** on the telephone base. You should hear the phone number being dialed.
6. After confirming that the call went to the phone number you programmed, press **🔊 SPEAKER** again to end the test. The idle screen appears.

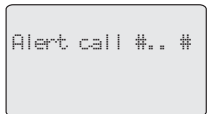
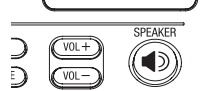
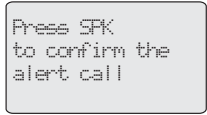
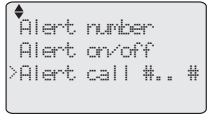

**NOTE:** If the alert number fails to dial out, you hear silence from the base, and the called phone does not ring.

## Remaining space

You can check the current system space for an estimated further recording time and number of messages.

1. When the telephone is idle, press **MENU/ENTER**.
2. Press **▲** or **▼** to scroll to **Mailbox setup**. Press **MENU/ENTER**.
3. Press **▲** or **▼** to scroll to **Remaining space**. Press **MENU/ENTER**.
4. After checking the screen display, press **MENU/ENTER** and return to the previous menu. Press **EXIT** to exit setup without making changes.

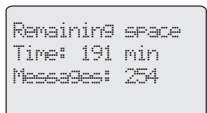
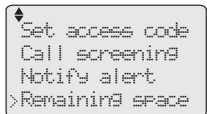
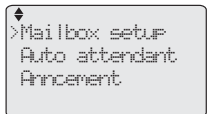

**NOTE:** The remaining recording time is an estimated data, it is because that the accuracy of the particular remaining space depends on what is recorded.

## COVM

If you subscribe to voice mail service with your local telephone service provider; turn the **COVM** (Central Office Voice Mail) on, **COVM** displays on the screen above the line button when a specific phone line receives any new voice mail message(s). If you do not subscribe to voice mail service or want to temporarily disable the indicator, turn the **COVM** off. If there are still messages waiting in the local telephone service provider, the screen displays the **COVM** indicator again when you turn this feature on, unless you set the **COVM reset** on the telephone base.

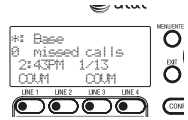

### COVM on/off

1. When the telephone is idle, press **MENU/ENTER**.
2. Press **▲** or **▼** to scroll to **COVM**. Press **MENU/ENTER**.
3. Press **▲** or **▼** to scroll to **COVM on/off**. Press **MENU/ENTER**.
4. Press **▲** or **▼** to select **On** or **Off**.
5. Press **MENU/ENTER** to save the setting and return to the previous menu. There is a confirmation tone. To exit without making changes, press **EXIT**.

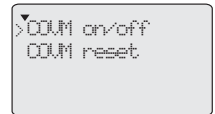
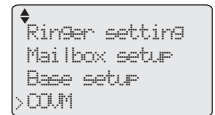

### COVM reset

You might have accessed your voice mail from a remote location (while away from the phone). You might have received a false signal from your local service provider. Use this feature to independently remove **COVM** indicator display above a specific phone line button and reset **COVM** condition for that line. You can reset **COVM** for all the phone lines at a time using **ALL COVM reset** operation.

1. When the telephone is idle, press **MENU/ENTER**.
2. Press **▲** or **▼** to scroll to **COVM**. Press **MENU/ENTER**.
3. Press **▲** or **▼** to scroll to **COVM reset**. Press **MENU/ENTER**.
4. Press **▲** or **▼** to scroll to **COVM 1-4 reset** to clear the **COVM** indicator of a phone line, or highlight **ALL COVM** to clear the indicators for all the lines at a time.
5. Press **MENU/ENTER** to save the setting and return to the previous menu. There is a confirmation tone. To exit without making changes, press **EXIT**.

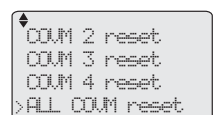
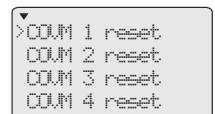
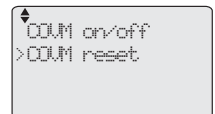

# COVM



**NOTE: COVM reset** feature only turns off the display indicator ; it does not delete your voice mail message(s). If there actually is a new voice mail message, your local telephone service provider resends the signal causing the indicator display for a specific phone line to appear on the screen again.

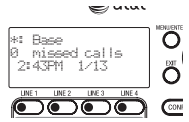

## Speed dial setup

The telephone base has ten speed dial locations where you can store the phone numbers you wish to dial using fewer keys than usual. You can store up to 32 digits in each location.

### Enter, edit or delete a speed dial number

- When the telephone is idle, press **MENU/ENTER**.
- Press **▲** or **▼** to scroll to **Speed dial setup**. Press **MENU/ENTER**.
- Press **▲** or **▼** to choose the desired speed dial location (>Speed dial **x**, **x** is the location number), then press **MENU/ENTER**.
- Use the dial pad to enter or edit the telephone number up to 32 digits. If you want to delete the entry, erase all the digits.
  - Press **◀** or **▶** to move the cursor to the left or right.
  - Press **REMOVE** to erase an digit.
  - Press and hold **REMOVE** to erase all the digits at a time.
- Press **MENU/ENTER** to save the setting and return to the previous menu. There is a confirmation tone. To exit without making changes, press **EXIT**.

```

▲ Mailbox setup
  Base setup
  CO.M
  >Speed dial setup
  
```

```

▼ >Speed dial 1
  Speed dial 2
  Speed dial 3
  Speed dial 4
  
```

```

◀▶ Enter phone no.:
    1234567 █
      Enter=Save
  
```

```

◀▶ Enter phone no.:
    123█567
      Enter=Save
  
```



#### NOTES:

- The speed dial feature occupies up to ten of the hundred memory locations in the directory. For example, if there are only five speed dial entries, then up to 95 entries can be stored in the directory. If there are already 100 entries in the directory, no new directory and speed dial entries can be stored in memory until some of the existing ones are deleted.
- If you press a dial pad key which does not save a number, the screen displays **No number**.

# Screen icons, indicator tones & lights

## Screen icons & alert tones

- **Screen icons**

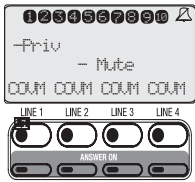

|       |   |
|-------|---|
|       | On when line 1, line 2, line 3, or line 4 is in use.  |
|       | Ringer off - the telephone base ringer is off.  |
| -Mute | Microphone is muted.  |
| -Priv | Call privacy is on.   |
| COVM  | There are new voicemail (on a phone line <b>LINE</b> x below the icon) from the local telephone provider. |

- **Alert tones**

|                          |  |
|--------------------------|--|
| <b>Four quick beeps</b>  | You are pressing the <b>VOL+</b> or <b>VOL-</b> when the volume is already at its highest or lowest setting. |
| <b>Double beeps</b>      | A transferred call has not been answered within every 30 seconds.  |
| <b>One short beep</b>    | A call is put on hold for more than six minutes and the <b>Hold reminder</b> is activated.                   |
| <b>Confirmation tone</b> | Command completed successfully.  |

- **Indicator lights**

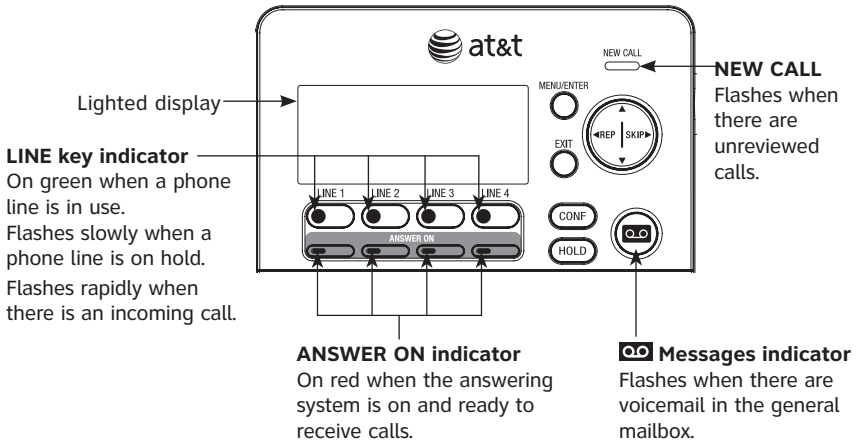

## Screen icons, indicator tones & lights

- **Indicator lights**

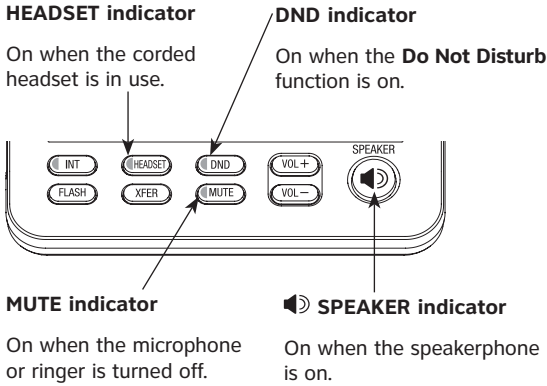



## Telephone base basic operation

The phone comes programmed to use line 1 (default primary line) for calls when you do not press a line key. (To change the primary line, see **Line Selection** on page X of the installation guide.) When you answer a call, the phone automatically selects the ringing line.

### Lit line indicators

---

The four indicators on the **LINE** keys indicate the state of the corresponding phone line.

The four **LINE** indicator lights are green:

- On when the corresponding line is in use.
- Flashes slowly when the line is on hold.
- Flashes rapidly when there is an incoming call on the corresponding line.
- Flashes rapidly when there is a transferred call on the corresponding line.
- Flashes rapidly when there is an incoming auto attendant transferred call on the corresponding line.

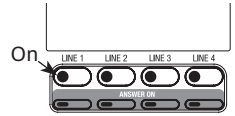

### Making a call

---

- **To make a call:**

1. Lift the handset or press **◀▶ SPEAKER**.

**-OR-**

To override automatic line selection, press the **LINE (1-4)** key for the desired line, then lift the handset.

2. Wait for a dial tone, then enter the telephone number and the screen displays the elapsed time as you talk (in hours, minutes and seconds).

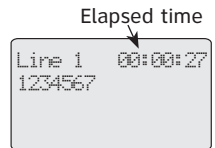

- **To end a call:**

Place the handset on the telephone base to hang up.

**-OR-**

If you are using speaker phone, press **◀▶ SPEAKER** to hang up.



**NOTE:** The elapsed time is not affected by accessing services from your local telephone service provider.

## Telephone base basic operation

### On-hook dialing (predialing)

---

1. Enter the telephone number. Press **REMOVE** to make corrections when entering the phone number.
2. Lift the handset or press **SPEAKER** to dial.

**-OR-**

To override automatic line selection, press the **LINE (1-4)** key for the desired line, then lift the handset.

### Telephone base speakerphone

---

During a call, press **SPEAKER** to switch between hands-free speakerphone and normal handset use. Press **SPEAKER** again or place the handset on the telephone base to hang up.

### Calling a speed dial number

---

1. Press and hold a dial pad key (**0-9**) to display the number. The dial pad key **0** represents for the tenth speed dial number.
2. Press **SPEAKER** or lift the handset.

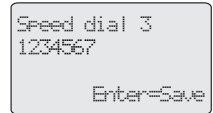

**-OR-**

To override automatic line selection, press the **LINE (1-4)** key for the desired line, then lift the handset.

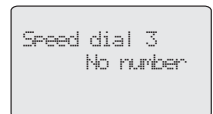
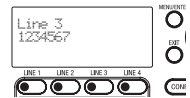

### Answering a call

---

#### To answer a call

- Lift the handset or press **SPEAKER**.
- OR-**
- To override automatic line selection, press the **LINE (1-4)** key for the desired line, then lift the handset.
- OR-**
- Press any dial pad key (**0-9, \* or #**)

# Telephone base basic operation

## Temporary ringer silencing

Press **MUTE** while the telephone is ringing to silence the ringer temporarily on the telephone base only. This turns off the ringer without disconnecting the call. The next incoming call rings normally at the preset volume

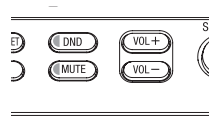

**NOTE:** You do not hear a ringer if you turn off the ringer tone. (See Turn on/off ringer tone on page X).

## Last number redialing

### To view the ten most recently dialed numbers

- To display the most recently called numbers (up to 30 digits), press **PAUSE/REDIAL**.
- To view up to ten recently called numbers, press **▲** or **▼**, or **PAUSE/REDIAL** repeatedly

Press **EXIT** to exit.

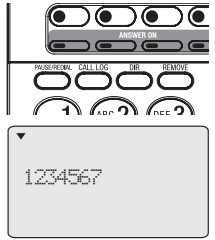

### To redial a number

- To dial the displayed number, lift the handset or press **▶** **SPEAKER**.
- To override automatic line selection, press the **LINE (1-4)** key for the desired line, then lift the handset.



### To edit a number

- While the desired number displays, press **MENU/ENTER** to enter editing mode.
- Press **◀** or **▶** to move the cursor to the left or right. Press **REMOVE** to erase digits.

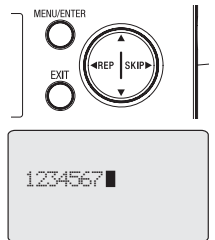

### To delete a number

- While the screen displays the desired number, press **REMOVE** to delete the number from the redial memory.

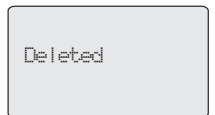

## Options while on calls

### Volume control

While on a call, press **VOL+** or **VOL-** to increase or decrease the listening volume.

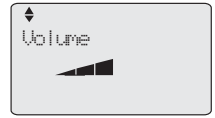

#### NOTES:

1. The corded headset and base handset volume settings are the same, but they have independent volume settings from the speakerphone volume settings.
2. While using the volume control, you will hear a triple beep when you've reached the minimum or maximum level.

### Call waiting

If you subscribe to call waiting service with your local telephone service provider, you hear a beep if someone calls while you are already on a call.

- Press **FLASH** to put your current call on hold and take the new call.
- Press **FLASH** at any time to switch back and forth between calls.

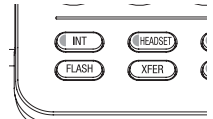

#### NOTES:

1. If you miss a call-waiting call, the caller ID of the missed call displays for 15 seconds after the current call.
2. For more information on caller ID with call waiting, see page XX.

### Call privacy

You can control call privacy. To ensure call privacy, this phone allows only one set at a time to use a line.

#### To enable call privacy

- During the call, press **MENU/ENTER**.
- Press **▲** or **▼** to scroll to **Privacy on**. Press **MENU/ENTER**.
- The screen displays **-Priv**. The other phones cannot join the call and the other phones drop from the call.

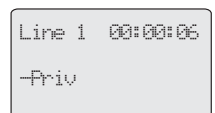
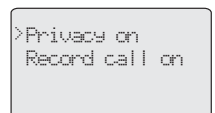
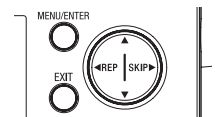

#### To cancel call privacy

- During the call, press **MENU/ENTER**.
- Press **▲** or **▼** to scroll to **Privacy off**. Press **MENU/EN-**

## Options while on calls

**TER** to exit the call privacy mode and continue with the conversation.

- The icon **-Priv** disappears from the screen. Others can now join the call by pressing the appropriate line key.

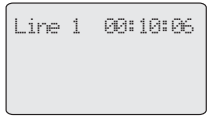
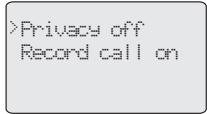

### NOTES:

1. Call privacy is automatically restored when you end a call.
2. You can not set call privacy during intercom or conference calls.
3. Call privacy setting does not work for a transferred call.
2. When a non-system phone answers a call, any other system phone can pick up the call by pressing the **LINE (1-4)** keys. Once a system phone picks up the call, call privacy is activated and no other system phones can listen to the call unless call privacy is cancelled, but non-system phones that share that line can still join the call.

## Two-way conversation recording

During an outside call, you can record the conversation as a private message in the general mailbox memory. It is saved, played back and deleted exactly like private incoming messages.

### • To record a two-way conversation

1. During the call, press **MENU/ENTER**.
2. Press **▲** or **▼** to scroll to **Record call on**. Press **MENU/ENTER**.
3. The screen displays **-Rec**, and the elapsed time while recording. Two-way conversations shorter than three seconds are not recorded.
4. The recording ends if you disconnect the call.

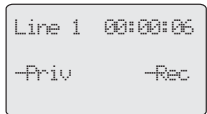
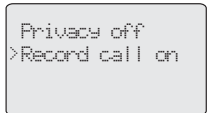

**-OR-**

Press **MENU/ENTER**, then select **Record call off** to exit the recording mode and continue with the conversation.

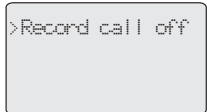

### • To play back a two-way conversation

Two-way conversations are stored as private messages. See **Private message playback** on page X for instructions on playback and deletion.



### NOTES:

1. Call privacy is automatically on during a two-way conversation recording.
2. You can not set two-way conversation recording during intercom or conference calls.

## Options while on calls

3.  **Messages** indicator does not flash for new and unreviewed two-way conversation recording.
4. This phone does not have warning beeps to inform the other party that the call is being recorded. To ensure that you are in compliance with any federal or state regulations regarding recording a telephone call, you should start the recording process and then inform the other party that you are recording the call.

### MUTE

---

You can use the mute function during a telephone conversation to silence the microphone. You can hear the caller, but the caller does not hear you.

#### To mute a call:

- Press **MUTE**. When mute is on, the **MUTE** light blinks, the screen shows **-Mute** and the **-Mute** appears until you turn off mute.

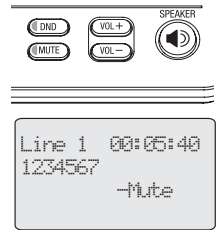

#### To un-mute a call:

- Press **MUTE** again and resume speaking.



**NOTE:** Switching from handset to speakerphone or corded headset, or from speakerphone or corded headset to handset, changing lines, or putting a call on hold also cancels the mute function.

### HOLD

---

You can use this feature to hold one line while accessing another, or as part of the conference and call transfer features.

While on a call, press and release **HOLD**. The **LINE** indicator for the line on hold flashes slowly in green, and a double-beep sounds every 30 seconds to remind you that the call is on hold. (To turn off the reminder beep, see **Hold reminder** on page X.)

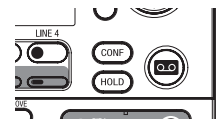

If you are using the base handset, you can place the handset in the telephone base without disconnecting the call. If you are using the speakerphone, the speakerphone turns off automatically when you press **HOLD**.

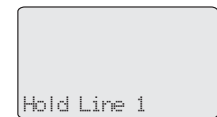

To release the hold, press and release the **LINE** key of the call on hold.



#### NOTES:

1. The phone automatically disconnects a call on hold after 20 minutes. To keep a call on hold longer than 20 minutes, release hold within 20 minutes and then place the call on hold again.
2. If a call is on hold for 3 minutes, a warning tone sounds every 30 seconds.

## Options while on calls

3. If there is an incoming call while the line is on hold, the screen alternatively displays **On hold** and **Incoming call**.
4. You cannot put an intercom call on hold.
5. If a line is in use, pressing **INT** places the line on hold and activates the intercom (pageX).

### Join in

You can join in an ongoing call on another extension handset when the call privacy is not set on that handset. The corresponding line icon (page X) displays on the screen when the line is in use.

- Press the desired **LINE (1-4)** key on the telephone base to join in the call.

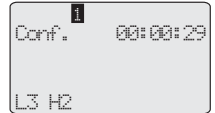

- **i NOTE:** When you try to join in the ongoing call on the handset with call privacy on, the screen displays **Privacy** and you hear quick beep tones.

### Chain dialing

You can initiate a dialing sequence from the numbers in the directory while you are on a call.

Chain dialing can be useful if you wish to access other numbers (such as bank account information or access codes) from the directory.

- **To access the directory while on a call:**
1. During the call, press **DIR**, then press **▲** or **▼** to review the directory.
  2. To dial the displayed number, press **MENU/ENTER**. To exit without making changes, press **EXIT** or **◀** and continue with the conversation.

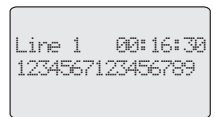
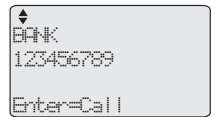
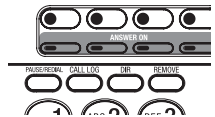

- **i NOTE:** You cannot edit a directory entry while on a call. For more details about the directory, see page X.

## Options while on calls

### Three-way conference calls

You can set up a three-party call by using two lines at the same time. You can also join an intercom call with a call on an outside line. The outside line call must be established first, because an intercom call cannot be placed on hold.

1. Make or answer an outside call.
2. Press **HOLD** and call someone on another line, or start an intercom connection.

**-OR-**

Call someone on another line, or intercom someone and the line is put on hold automatically.

3. When this call is answered, press **CONF**. The three-party conference begins immediately.

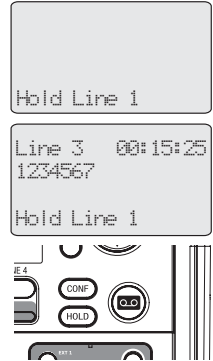

- **To talk privately with one external party (two-line conference only):**

1. Press **HOLD** to place both lines on hold.
2. Press a **LINE** key to talk privately with the person on that line.
3. Press **Conf** to resume the conference call.

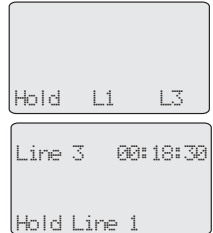

- **To talk privately with one internal party (two-line conference only):**

1. Press **INT** to talk privately with the person on that handset and place the external line on hold automatically.
2. Press **Conf** to resume the conference call.

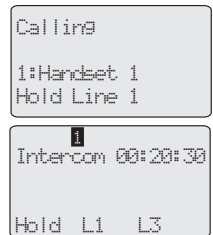

- **To drop one line:**

Press the **LINE** key for the party you want to keep. The other line is dropped.

- **To drop an intercom:**

Press the **LINE** key to activate the external call. The intercom call drops automatically.



## Options while on calls

### Three-way conference calls

You can set up a three-party call by using two lines at the same time. You can also join an intercom call with a call on an outside line. The outside line call must be established first, because an intercom call cannot be placed on hold.

1. Make or answer an outside call.
2. Press **HOLD** and call someone on another line, or start an intercom connection.

**-OR-**

Call someone on another line, or intercom someone and the line is put on hold automatically.

3. When this call is answered, press **CONF**. The three-party conference begins immediately.

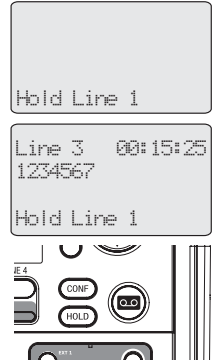

- **To talk privately with one external party (two-line conference only):**

1. Press **HOLD** to place both lines on hold.
2. Press a **LINE** key to talk privately with the person on that line.
3. Press **Conf** to resume the conference call.

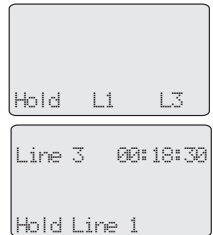

- **To talk privately with one internal party (two-line conference only):**

1. Press **INT** to talk privately with the person on that handset and place the external line on hold automatically.
2. Press **Conf** to resume the conference call.

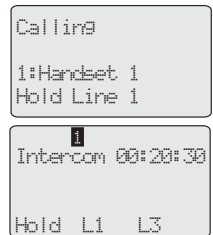

- **To drop one line:**

Press the **LINE** key for the party you want to keep. The other line is dropped.

- **To drop an intercom:**

Press the **LINE** key to activate the external call. The intercom call drops automatically.

## Options while on calls

- **To end a conference call:**

Place the handset on the telephone base to hang up. All parties will be disconnected.



**NOTES:**

1. An internal party can put the conference call on hold.
2. An internal party hangs up, and the ongoing call becomes a two-way conversation.
3. Occasionally, the far-end parties on a conference call might not hear one another.
4. If you are experiencing difficulty in using the conference features on this phone, please consider using AT&T's complete line of teleconference services to find a solution that best meets your needs. AT&T TeleConference Services reduces travel time and expense while increasing productivity wherever people are located, enabling you to host truly virtual meetings and share important information in real time. To sign up for AT&T TeleConference Services, go to : **[www.att.com/orderconference](http://www.att.com/orderconference)** for details.

## Intercom

A telephone base connected with normal AC power but not with any telephone lines plugged in can still intercom with charged and registered accessory cordless handsets.

When the system is making one or more external calls, the other registered cordless handsets (and cordless headset) can make intercom calls with each other. An intercom call can proceed between the telephone base and an accessory cordless handset at any given time, or between two registered accessory cordless handsets (or one of the two accessory unit is a registered cordless headset).

### Make an intercom call with the cordless handset

---

- Press the one-touch key for the destination party, then lift the handset. The screen displays **Calling X: Handset X** (X represents the extension and handset number).

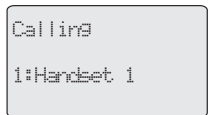

If the extension you are calling is idle or set to **Do Not Disturb (DND)**, you hear long beeps. If the other extension is on a call, you hear a busy signal.



#### NOTES:

1. Before the destination party answers the intercom call, press the corresponding **LINE (1-4)** key to resume the call.
2. The intercom call automatically cancels if the destination party does not answer it for 1 minute.

### Answer an intercom call

---

You can answer an intercom call. When you receive an intercom call, you hear a ringing tone and your screen displays **Call: X Handset X** (X represents the extension and handset number). Answer the intercom call by lifting the handset, or by pressing **◀▶ SPEAKER** or **HEADSET** to take the call hands-free.



### End an intercom call

---

- Put the handset on the telephone base or press **HEADSET** again to hang up.

## Intercom

### **Make another intercom call while on an intercom call**

---

You can make an intercom call to another destination extension while on an intercom call. The first intercom automatically disconnects. While on an intercom call:

- Press the one-touch key for another destination party. The screen displays **Calling X: Handset X** (X represents the extension and handset number).

If the extension you are calling is idle or set to **Do Not Disturb (DND)**, you hear long beeps. If the other extension is on a call, you hear a busy signal.



#### **NOTES:**

1. Before the destination party answers the intercom call, press the corresponding **LINE (1-4)** key to resume the call.
2. The intercom call automatically cancels if the destination party does not answer it for 1 minute.

## Call transfer

### Transfer a call

---

You can transfer a call to any other system phone. Once you transfer a call, it can be picked up at any other system phone, not just at the extension you called.

 **NOTE:** If a transferred call is not picked up within 20 minutes, the phone automatically disconnects the call.

### Blind transfer

---

You can make a blind transfer. While on a call:

1. Press **XFER**. The outside call is automatically put on hold. **Transfer LINE X to** appears on the screen display.
2. Press the one-touch key for the destination extension.

**-OR-**

Dial the destination extension number to which you are transferring the call. The extension number appears on the **fourth** line of the display.

3. Put the base handset on the telephone base or press  **SPEAKER** to hang up.

Your phone reminds you with a double-beep every 30 seconds when a transferred call has not been answered. (To turn off the reminder beep, see **Hold reminder** on page X).

 **NOTE:** If you do not dial an extension within 10 seconds, the transfer automatically cancels. The call is still on hold. Press the corresponding **LINE (1-4)** key to resume the call.

### Transfer a call and speak to the receiving party

---

You can transfer a call and speak to the receiving party. While on a call:

1. Press **INT**. The outside call is automatically put on hold and **INTERCOM TO** displays followed by the destination extension number.
2. Press the one-touch key for the destination extension to which you are transferring the call.

**-OR-**

Dial the destination extension number to which you are transferring the

## Call transfer

- call. The extension number appears on the **fourth** line of the display.
3. When the other party answers by pressing **INT**, you can announce the call.
  4. Press **XFER**.
  5. Put the base handset on the telephone base or press **🔊** **SPEAKER** to hang up.



**NOTE:** If you do not dial an extension number within 10 seconds, the transfer automatically cancels. The call is still on hold. Press the corresponding **LINE** key to resume the call.

### **Answer a transferred call**

---

When you hear a long transfer ring, pick up the handset or press the **LINE** key of the call to use the speakerphone or headset.

## Push to talk (PTT)

You can directly send your voice to the speaker of the registered and in idle mode extension handset(s). The extension you called can respond just by talking while pressing the **PTT** key on the cordless handset. -

### **PTT to an handset**

---

- Press and hold the one-touch key **EXT 1-0** for the destination party while speaking into the base speakerphone.
- Release the one-touch key **EXT 1-0** after speaking.



**NOTE:** The speakerphone on the destination telephone is activated automatically when you press and hold the one-touch key.

### **PTT to all handsets**

---

- Press and hold the one-touch key **INT/PTT ALL** for all the extension handsets while speaking into the base speakerphone.
- Release the one-touch key **INT/PTT ALL** after speaking.

### **Answer a PTT call**

---

- The screen displays **Push2TalkIncoming** and the caller extension number.
- Press and hold the one-touch key for the extension number while speaking into the base speakerphone.



**NOTES:**

1. If the destination telephone is in the **Do Not Disturb** mode, on an intercom call or on an outside call, your telephone sounds a busy signal.
2. If the destination telephone is a non-registered handset, the screen displays InvalidMailbox.

## About the directory

### **Capacity**

---

The directory of this telephone base can store up to 100 entries, with a maximum of 16 alphanumeric characters (including spaces) for names and 32 digits for telephone numbers. A convenient search feature can help you quickly find and dial numbers (page X).

If there are already 100 entries, the screen shows **LIST FULL**. You cannot store a new number until you delete one. If you try to view the directory entries when there are no entries, the screen displays **Directory empty**.

### **Exit the directory**

---

Press **EXIT** to cancel an operation and return to the idle mode.

If you pause for too long while creating or reviewing an entry, the procedure times out and you have to begin again.



# Create directory entries

## Create a new directory entry

You can use the following steps to store a name and number in the directory.

1. When the telephone is idle, press **MENU/ENTER**.
2. Press **▲** or **▼** to scroll to **Directory**. Press **MENU/ENTER**.

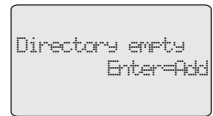
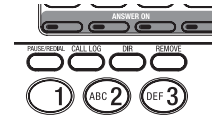
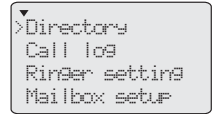

**-OR-**

When the telephone is idle, press **DIR**.

3. Press **MENU/ENTER** to add an entry.
4. Enter the telephone number when prompted.
  - Use the dial pad to enter up to 32 digits.
    - Press **◀** or **▶** to move the cursor to the left or right.
    - Press **REMOVE** to erase digits.
    - Press and hold REMOVE to erase all digits.
    - Press **REDIAL/PAUSE** to enter a three-second dialing pause (a **P** appears).
5. Press **MENU/ENTER** to enter the name when prompted.
  - Use the dial pad to enter a name (up to 16 characters). Each time you press a key, the character on that key appears. Additional key presses produce other characters on that key. See the chart below.

| Number key | Characters by number of key presses |   |   |   |   |   |   |   |   |
|------------|-------------------------------------|---|---|---|---|---|---|---|---|
|            | 1                                   | 2 | 3 | 4 | 5 | 6 | 7 | 8 | 9 |
| 1          | 1                                   | # | ' | , | - | . | & |   |   |
| 2          | A                                   | B | C | 2 | a | b | c |   |   |
| 3          | D                                   | E | F | 3 | d | e | f |   |   |
| 4          | G                                   | H | I | 4 | g | h | i |   |   |
| 5          | J                                   | K | L | 5 | j | k | l |   |   |
| 6          | M                                   | N | O | 6 | m | n | o |   |   |
| 7          | P                                   | Q | R | S | 7 | p | q | r | s |
| 8          | T                                   | U | V | 8 | t | u | v |   |   |
| 9          | W                                   | X | Y | Z | 9 | w | x | y | z |
| 0          | 0                                   |   |   |   |   |   |   |   |   |
| *          | *                                   | ? | ! | / | ( | ) | @ |   |   |
| #          | space                               |   |   |   |   |   |   |   |   |

## Create directory entries

- Press ◀ or ▶ to move the cursor to the left or right.
- Press **REMOVE** to erase characters.
- Press and hold REMOVE to erase all characters.
- Press # to add a space.

6. Press **MENU/ENTER** to store your new directory entry. There is a confirmation tone. The name and the telephone number appear. You cannot save the same number twice. To exit without making changes, press **EXIT**.



## Review directory

### Review directory entries

---

1. When the telephone is idle, press **MENU/ENTER**.
2. Press **▲** or **▼** to scroll to **Directory**. Press **MENU/ENTER**.

**-OR-**

When the telephone is idle, press **DIR**.

3. Press **▲** or **▼** to browse through the directory. Entries appear alphabetically by the first letter in the name.  
**Directory empty** appears if there are no directory entries.

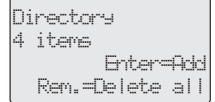

Directory  
4 items  
Enter=Add  
Rem.=Delete all

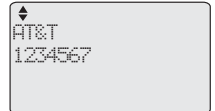

↕  
AT&T  
1234567

# Search directory

## Search by name

---

Follow the steps below to search for directory entries on the telephone base.

1. When the telephone is idle, press **MENU/ENTER**.
2. Press **▲** or **▼** to scroll to **Directory**. Press **MENU/ENTER**.

**-OR-**

When the telephone is idle, press **DIR**.

3. When a name entry appears, press the dial pad keys (**2-9**) to start a name search.

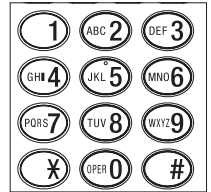

The directory shows the first name beginning with the first letter associated with the dial pad key if there is an entry in the directory beginning with that letter.

4. To see other names starting with the letters on the same dial pad key, keep pressing the key. The names appear in alphabetical order.

For example, if you have the names **Jennifer**, **Jessie**, **Kevin** and **Linda** in your directory:

- If you press **5 (JKL)** once, you see **Jennifer**.
- If you press **5 (JKL)** twice, you see **Jessie**.
- If you press **5 (JKL)** three times, you see **Kevin**.
- If you press **5 (JKL)** four times, you see **Linda**.
- If you press **5 (JKL)** five times, you see **Jennifer**.

### **NOTES:**

1. If there are no names matching the first letter of the key you press, the directory shows the name(s) matching the subsequent letters of the key.
2. If you press a key (**2-9**) and no name starts with the letters on that key, the directory shows the entry matching the next letter in the directory.

## Dial, delete or edit entries

You can dial, delete or edit a directory entry (name and number), the entry must be shown on the telephone base screen. You can use the directory review or search (pages X-X) to show an entry.

### Display dial

---

You can dial a displayed number from the directory,

1. Find the entry for the number you wish to call by following the directions under **Review directory entries** on page X.
2. Dial the displayed number:
  - Lift the handset or press **SPEAKER**.
  - To override automatic line selection, press the **LINE** key for the desired line, then lift the handset.

### Delete an entry

---

When a directory entry appears, press **REMOVE** on the telephone base to delete the displayed entry from the directory. You cannot retrieve a deleted entry.

### Edit an entry

---

- When a directory entry appears,
  - Press the dial pad keys to add digits.
  - Press **REMOVE** to erase digits.
  - Press and hold **REMOVE** to erase all digits.
  - Press **◀** or **▶** to move the cursor to the left or right.
  - Press **REDIAL/PAUSE** to enter a three-second dialing pause (a **P** appears).
- Press **MENU/ENTER** to store your new directory entry. There is a confirmation tone. The name and the telephone number appear. You cannot save the same number twice. To exit without making changes, press **EXIT**.

## About Caller ID

This product supports caller ID services that most local telephone service provider offers. Depending on your service subscription, you might see the caller's number, or the caller's name and number from the telephone company after the first or second ring. Caller ID allows you to see the name, number, date and time of calls.

### **Information about caller ID with call waiting**

---

Caller ID with call waiting lets you see the name and telephone number of the caller before answering the telephone, while on another call.

There are fees associated with caller ID services. In addition, this service might be called by different names (such as caller ID with visual call waiting) by different local telephone service provider and might not be available in all areas.

It might be necessary to change your telephone service to use this feature. Contact your telephone service provider if:

- You have both caller ID and call waiting, but as separate services (you might need to combine these services)
- You only have caller ID service, or only call waiting service.
- You do not subscribe to caller ID or call waiting services.

This product can provide information only if both you and the caller are in areas offering caller ID service and if both telephone service provider use compatible equipment. The time and date are from the telephone service provider along with the call information.

Caller ID information might not be available for every incoming call. Callers may intentionally block their names and/or telephone numbers.



#### **NOTES:**

1. You can use this product with regular caller ID service, or you can use this product's other features without subscribing to caller ID or combined caller ID with call waiting service.
2. The format of telephone numbers displayed depends on the home and local area codes you set (See the **Area codes** section on page X of the manual for explanations and setting instructions of area codes).

# Caller ID history

## How the caller ID history (call log) works

The telephone stores caller ID information for the last 50 incoming calls in the telephone base. Entries are stored in reverse chronological order. The phone deletes the oldest entry when the log is full to make room for new calls. This information is shared by the telephone base and all system handsets. If you answer a call before the information appears on the screen, it does not show in the caller ID history.

Review the caller ID history to determine who called, to easily return the call, or to copy the caller's name and number into your directory.

**NEW CALL** indicator lights and **XX missed call(s)** appears if there are new call log entries (including missed and unreviewed calls).

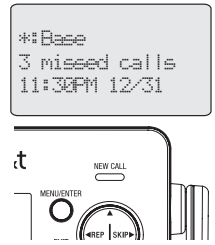

The time and date of the call and the caller's name and phone number are included in the display.

Caller ID information appears on the screen as the phone rings, or until the caller hangs up, or until the call has been answered at another extension, or until the call ends.

If you subscribe to caller ID service, this phone automatically resets the time and date each time new call information is received. You can also set the time and date yourself (see **Time adjustment** on page X).

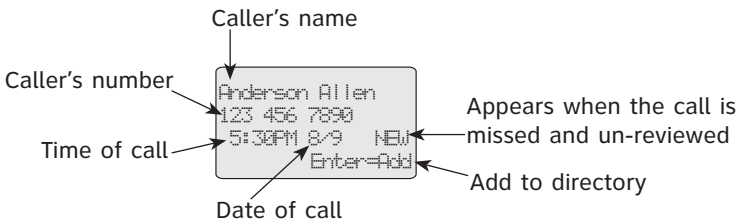

### Screen display of the telephone base

**i NOTES:**

1. Each entry may have up to 32 digits for the phone number and 16 characters for the name. If the phone number has more than 16 digits, only the last 16 digits appear.
2. The callers might intentionally block their names and/or telephone numbers.

# Caller ID operation

## Memory match

If the incoming telephone number is an exact match with a telephone number in your directory, the name that appears on the screen matches the corresponding name in your directory.

For example, if Christine Smith calls, her name appears as Chris if this is how you entered it into your directory.



**NOTE:** The number you see on your caller ID is in the format from the telephone service provider. It usually delivers ten-digit phone numbers (area code plus phone number). If the telephone number of the caller is not an exact match with a number in your directory, the name appears from the telephone service provider records. For example, if the phone company includes the area code and the directory number does not, the name appears as delivered by the phone company.

## Missed (new) calls indicator

When the telephone base is in idle mode and has unreviewed calls, its screen shows **XX missed call(s)**.

All unreviewed entries are counted as missed calls. Each time you review a call log entry with the icon **NEW**, the number of missed calls decreases by one. When all the entries in the caller ID history become old (have been reviewed), the system removes the missed calls alert from the display, and the **NEW CALL** indicator turns off.

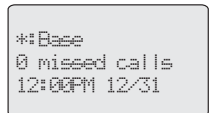
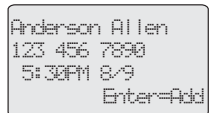

## Review the caller ID history

1. When the telephone is idle, press **MENU/ENTER**.
2. Press **▲** or **▼** to scroll to **Call log**. Press **MENU/ENTER**.

**-OR-**

When the telephone is idle, press **CALL LOG**.

3. Press **▲** or **▼** to review the caller ID history. The caller ID history displays the caller ID entries in reverse chronological order starting with the most recent call.
4. To exit without making changes, press **EXIT**.

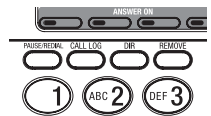
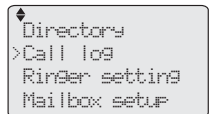



## Caller ID operation

### Make a call log entry ready to dial

Although the incoming call log entries have 10 digits (the area code plus the seven-digit number), in some areas, you may only need to dial the seven digits, 1 plus the seven digits, or 1 plus the area code plus the seven digits. You can change and store the number of digits that you dial in the call log.

While reviewing the call log, press **#** repeatedly on the telephone base to show different dialing options for local and long distance numbers before dialing or saving the telephone number in the directory.

Press **1** repeatedly on the telephone base if you need to add or remove 1 in front of the telephone number before dialing or saving it in the directory.

When the number shows in the correct format for dialing,

1. Lift the handset or press **SPEAKER**.
2. To override automatic line selection, press the **LINE** key for the desired line, then lift the handset.
4. To exit without making changes, press **EXIT**.

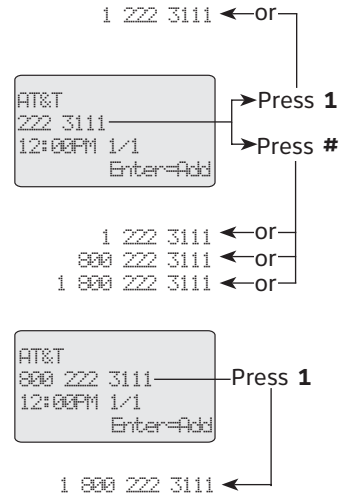

### Dial a call log entry

1. When in the call log, press **▲** or **▼** to browse the number you wish to call.
2. Lift the handset or press **SPEAKER**.
3. To override automatic line selection, press the **LINE (1-4)** key for the desired line, then lift the handset.
4. To exit without making changes, press **EXIT**.

### Delete entries

#### • Delete an caller ID entry

1. When in the call log, press **▲** or **▼** to browse the number you wish to delete.
2. Press **REMOVE** to delete the shown entry from the caller ID history.

## Caller ID operation

### • Delete all caller ID history

1. When the telephone is idle, press **MENU/ENTER**.
2. Press **▲** or **▼** to scroll to **Call log**. Press **MENU/ENTER**.

```
Call log
3 missed calls
Rem.=Delete all
```

### -OR-

When the telephone is idle, press **CALL LOG**.

3. Press **REMOVE**. The screen displays **Erase all?** Press **▶** to clear the caller ID history of all entries, or press **◀** to exit and leave all entries in the caller ID history intact.
4. To exit without making changes, press **EXIT**.

```
Erase all?
<=No      >=Yes
```

```
Deleted
```

### Save a call log entry to the directory

1. When in the call log, press **▲** or **▼** to browse the number you wish to save.
2. The screen displays **Enter=Add**. Press **MENU/ENTER**.
3. When a call log entry appears,
  - Press the dial pad keys to add digits.
  - Press **REMOVE** to erase digits.
  - Press and hold REMOVE to erase all digits.
  - Press **◀** or **▶** to move the cursor to the left or right.
  - Press **REDIAL/PAUSE** to enter a three-second dialing pause (a **P** appears).
4. The screen displays **Enter=Next**. Press **MENU/ENTER** to move to the name.
  - Press the dial pad keys to add characters.
  - Press **REMOVE** to erase characters.
  - Press and hold REMOVE to erase all characters.
  - Press **◀** or **▶** to move the cursor to the left or right.
  - Press **#** to enter a space.
5. Press **MENU/ENTER** to save your new directory entry. There is a confirmation tone. The name and the telephone number appear. You cannot save the same number twice.
  - If the entry is already saved in the directory, the screen display remains the same and waits for editing.

```
AT&T
1 800 222 3111
12:00PM 1/1
Enter=Add
```

```
◀▶
Enter phone no.:
18002223111■
Enter=Next
```

```
◀▶
Enter name:
AT&T■
Enter=Save
```

```
AT&T
1 800 222 3111
```

## Reasons for missing caller ID information

- If there is no caller ID information, you hear an error tone. The number is unable to save.

6. To exit without making changes, press **EXIT**.

 **NOTE:** You might need to change how a caller ID number is dialed if the entry does not appear in the correct format. Caller ID numbers might appear with an area code that might not be necessary for local calls, or without a 1 that might be necessary for long distance calls (see page X, **Make a call log entry ready to dial**).

### Reasons for missing caller ID information

There are also occasions when other information or no information shows for various reasons:

| On-screen message | Reason  |
|-------------------|---|
| PRIVATE NUMBER    | The caller prefers not to show the phone number.  |
| PRIVATE NAME      | The caller prefers not to show the name.  |
| PRIVATE CALLER    | The caller prefers not to show the phone number and name.   |
| UNKNOWN NUMBER    | Your local telephone service provider cannot determine the caller's number.   |
| UNKNOWN NAME      | Your local telephone service provider cannot determine the caller's name.   |
| UNKNOWN CALLER    | Your local telephone service provider cannot determine the caller's name and telephone number. Calls from other countries may also generate this message. |

## About the answering system

Your telephone has a digital answering system, including an auto attendant and voicemail features, to select a desired answering method for incoming calls. You can have a customized answering system setup for each phone line. You can manage all voicemail messages of phone line through the general mailbox feature on the telephone base.

### **Answering system capacity**

---

You can record up to five new announcements to have different announcements for each line. Each announcement can be up to two minutes.

Auto attendant and voicemail announcements both require system memory to record, so we suggest recording brief announcements in order to leave more space for messages.

The answering system can record up to 255 messages, depending on the length of each message. Individual messages can be up to three minutes. Messages remain available for review until you delete them.

If the system memory is full, you cannot record new messages until old ones have been deleted.

Check **Remaining space** (see page X) frequently to keep maintain availability of space for incoming messages.

### **Turn the answering system on or off at the telephone base**

---

- **Turn on the answering system**

You can turn the answering system on as either an auto attendant feature mode or voicemail mode.

Please refer to **Turn on the auto attendant** on page X.

Please refer to **Turn on the mailbox** on page X.

- **Turn off the answering system**

You can turn the answering system off, but if you do so, the answering system does not answer calls and record incoming messages.

Please refer to **Turn off the auto attendant** on page X.

Please refer to **Turn off the mailbox** on page X.

### **New message indication**

---

## About the auto attendant

If you want your telephone base to automatically answer incoming calls for your system, to announce the directory, and to enable your callers to record central system messages, you need to customize **Auto attendant setup** (see page X).

If the auto attendant is active and is answering or directing a call or playing or recording an announcement or message, the **LINE (1-4)** light flashes sequentially (page X). To interrupt the auto attendant, press the flashing **LINE (1-4)** key to talk to the caller on that line, or press any other **LINE (1-4)** key to disconnect this call and make a new call on another line.

An auto attendant assigned to a phone line can only answer one call at a time, so you might want to have more than one auto attendant in your system so that even when a call on one line is being answered, a second auto attendant telephone can answer another ringing line. You can designate up to 4 auto attendants in your system.



### NOTES:

1. Only outside calls are answered by an auto attendant.
2. The auto attendant phone does not answer calls when the phone is being used for setup, message review, call history review, or a phone call.

# Auto attendant operation

## Using multiple auto attendants

---

You can set one or more phone lines to act as auto attendant(s) when the primary auto attendant is turned off or busy.

An auto attendant is busy when someone at that extension is doing any of the following:

- programming the phone
- accessing messages
- on an intercom call
- dialing from the directory or call history
- using any of the lines to make or answer a call
- when the answer system is recording a message at that extension

You can choose a particular phone line to always be the primary auto attendant by setting that line to have the shortest auto attendant pickup delay (number of rings) and setting the pickup delays of other auto attendants for you to choose. If the auto attendant pickup delays are the same, incoming calls might be distributed randomly to the auto attendants.

## Auto attendant sequence for callers

---

When you set this telephone base to be an auto attendant, it automatically picks up a ringing line after the number of rings you programmed (see Number of rings on pageX), and plays the appropriate auto attendant announcement.

```
*:Base  
3 missed calls  
11:30PM 12/31  
A:At
```

When a caller enters a correct extension number after hearing the announcement, the auto attendant transfers the call to that extension and announces to the caller, *"Calling that extension. Please wait."*

The auto attendant continues to monitor the call after it is transferred. If the extension is set to use mailbox, the mailbox answers and can record an incoming extension message. If neither the requested extension nor its mailbox picks up within XX seconds, the auto attendant announces, *"That extension is not answering. Enter a new extension number, or , to leave a central message in the general mailbox, please dial nine."* The auto attendant attempts to transfer the call up to five times. If the call is not picked up by any extension during those attempts, the call is dropped.

### NOTES:

1. If someone at the requested extension picks up the call and subsequently places the call on hold

## Auto attendant operation

again, that extension must pick up the call again within X minutes or the call is dropped. The XX minutes restarts each time and same call is placed on hold.

2. If the memory is full or the auto attendant is turned off on the extension, no extension messages can be recorded in the general mailbox.

**If the caller presses 0 after hearing the message,** the auto-attendant directory plays. The caller can then decide whether to enter an extension number or not, and the auto attendant responds as described above.

**If the caller does not enter an extension number after hearing the announcement,** the auto attendant waits about X seconds, then transfers the call to extension X. If the call is not picked up after X seconds, the auto attendant answers the call again, and plays "That extension is not answering. Enter a new extension number, or , to leave a central message in the general mailbox, please dial nine." and wait X seconds for the entry. If the caller still hasn't entered an extension number after hearing this message five times, the auto attendant announces, "That extension is not answering. Thank you" and drops the call.

**If the caller enters an invalid extension number,** the auto attendant announces, "*The system does not recognize that extension. Please check it, and enter it again.*"

# Auto attendant operation

## Auto attendant flow chart

---

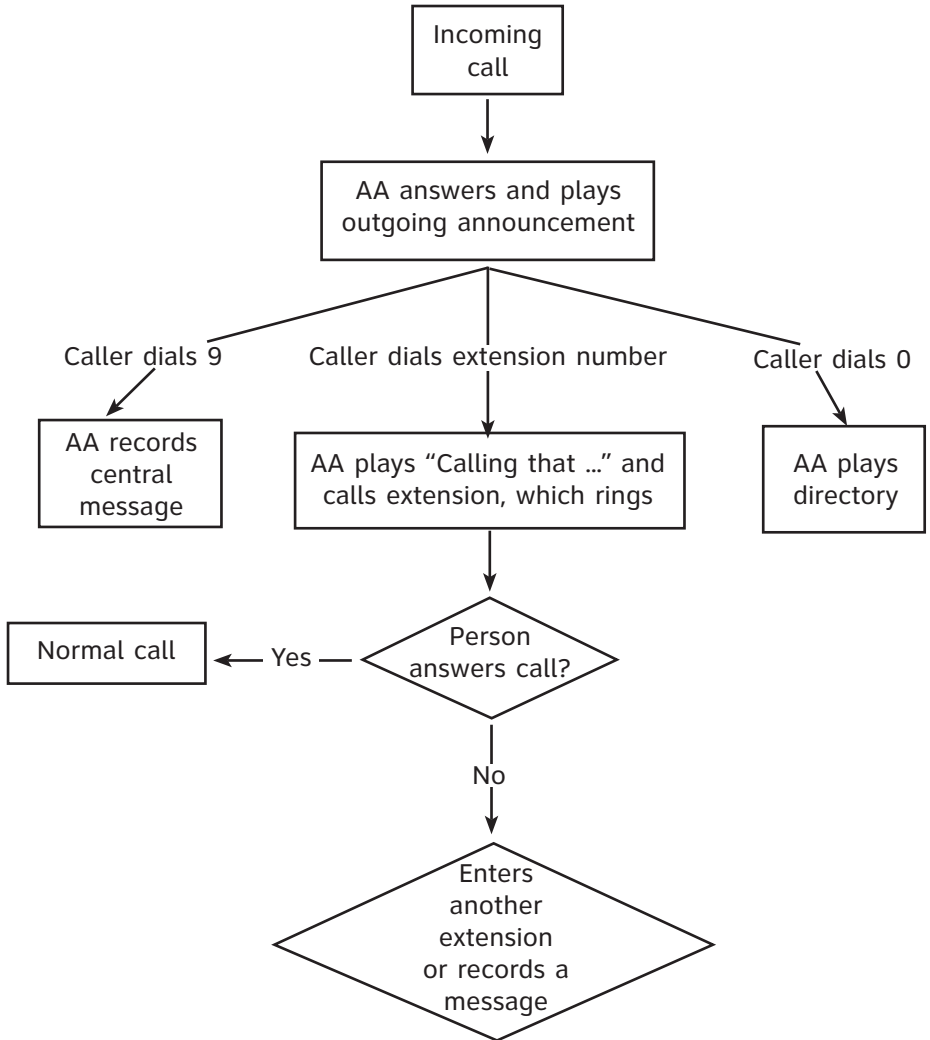

**NOTE:** If the caller enters an extension number that is not answered by a person or by that extension, and if its mailbox is busy (not able to answer and record), then the caller is returned to the auto attendant, with the message "That extension is not answering. Enter a new extension number, or, to leave a central message in the general mailbox, please dial nine."



## Voicemail operation

### Incoming messages

---

If your telephone is not set up as an auto attendant, it stores messages in the general mailbox.

If your telephone is an auto attendant, it can store two kinds of messages:

Private messages - including incoming messages, memos and two-way conversations. (page X)

Central messages (**COVM**) are the incoming messages recorded in the local telephone service provider which you subscribe to voice mail service. You can access the telephone service provider with your access code to playback the messages. The **COVM** indicator displays on the telephone base screen to remind you of a new and unreviewed messages (page X).

### New message indicator

---

The  **Messages** indicator on the telephone base flashes when there are new and unreviewed voicemails in the general mailbox.

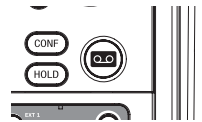



### Message playback

---

If you have new messages, you hear only the new messages (oldest first). If there are no new messages, the system plays back all the messages (oldest first).

When playback begins, the total number of messages is announced. Before each message, you hear the day and time of the recording. After the last message, you hear, *"This is the last message."*

To listen to messages at the telephone base:

1. While the telephone is idle, Press  **Messages** on the telephone base.
2. The system announces the number of new and unreviewed messages in the general mailbox.
3. Press **Play all** to listen to all messages. Press **◀ REP** to repeat the message, press **◀ REP** twice to listen to the previous message. Press **▶ SKIP** to move forward to the next message. There is a long beep after each message playback as a separator.
4. Playback ends after playing all the messages, and then returns to the previous menu.
5. Press  **Messages** again to end the message playback at any time.

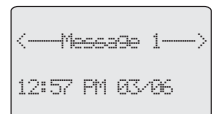
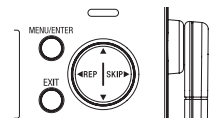
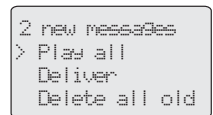

## Voicemail operation

### Options during playback

---

When a message is playing, you can adjust the playback volume, skip, repeat, or delete the message.

#### When messages are playing on the telephone base:

- Press **VOL+ / VOL-** key to adjust the message playback volume.
- Press **▶ SKIP** to skip to the next message.
- Press **◀ REP** to repeat the message. Press twice to hear the previous message.
- Press **REMOVE** to delete the message. The system announces, "Message is erased."
- Press **☎ Messages** to stop the playback.

### Record and deliver message memo

---

Message memos are messages you record into the general mailbox at the telephone base. You can save, play back, and delete them like incoming messages. You can record a memo as a reminder to yourself, or leave a message and transfer to other extensions using the answering system.

#### To record a memo, then deliver it:

1. When the telephone is idle, press **☎ Messages** on the telephone base.
2. Press **▲** or **▼** to scroll to **Deliver**. Press **MENU/ENTER**.
3. Press **▲** or **▼** to scroll to select a desired registered extension you wish to transfer to or select all the registered extension handsets,  
**X: Handset X - #: All**. Press **MENU/ENTER**.
4. Press **MENU/ENTER**. You can start recording after the tone. The timer starts counting.
5. Press **MENU/ENTER** again to stop recording. The timer stops and the recorded message memo automatically plays back. The screen displays **1=Change, 2=OK**.
6. Press **2** to save the setting and the message memo is transferred to the extension you selected. The system announces, "You message transferred to mailbox X.", and then returns to the previous menu, or press **1** to re-record that message memo.

```
2 new messages
  Play all
> Deliver
  Delete all old
```

```
↓
1:Handset 1
> 2:Handset 2
#:All
```

```
Message record
Enter=Start
```

```
Message record
00:32
Enter=End
```

```
Message check
00:09
1=Change    2=OK
```

```
Msg. transferred
to mailbox 2
```

## Voicemail operation

**-OR-**

To exit without making changes, press **EXIT**.



**NOTE:** If you record a message memo less than 5 seconds, the message is not saved as a message in the general mailbox.

### Play back a message memo

---

Play message memos the same way as messages. See Message playback on page X.

### Delete all old messages

---

You can only delete old (reviewed) messages. You cannot delete new messages until you review them. You cannot retrieve deleted messages.

#### Delete all old messages on the telephone base:

1. When the telephone is idle, press **Messages** on the telephone base.
2. Press **▲** or **▼** to scroll to **Delete all old messages**. Press **MENU/ENTER**.
3. The screen displays **<=No, Yes=>**. Press **◀** to cancel this operation, and returns to the previous menu, or press **▶** to remove all old messages from the general mailbox.

```
2 new messages
Play all
> Deliver
Delete all old
```

```
Delete all old
messages
<=>      Yes=>
```

```
All erased.
```



**NOTE:** If there is new and unreviewed message(s) in the general mailbox, the **Messages** indicator will still flash after you delete all old messages.

## Remote access

You can reach your answering system remotely by dialing your telephone number from any touch-tone telephone.











### To remotely reach your answering system:

1. Dial your telephone number from any touch-tone telephone.
2. When the system answers, enter the two digit remote access code (**0000** is the default code, see page X to change it).

The system automatically announces the number of messages (new and/or old) if there are any, and then begins to play them.

3. You can also enter the following remote commands.

### Remote commands

|  |   |
|--|---|
|    | <ul style="list-style-type: none"> <li>• Press to play to all messages.</li> <li>• Press to record a new announcement (during announcement playback).</li> </ul>  |
|    | <ul style="list-style-type: none"> <li>• Press to accept the recorded announcement (during announcement playback).</li> </ul>   |
|    | <ul style="list-style-type: none"> <li>• Press to delete the current message (during playback).</li> <li>• Press to delete the recorded announcement (during announcement playback).</li> </ul>   |
|    | <p>Press to repeat the current message (during playback).</p>   |
|    | <p>Press twice to listen to the previous message (during playback).</p>   |
|  | <ul style="list-style-type: none"> <li>• Press to repeat the list of remote commands.</li> <li>• Press to stop and return to the remote commands (during playback).</li> <li>• Press to end the recording (during recording announcement).</li> </ul> |
|  | <p>Press to skip to the next message (during playback).</p>   |
|  | <p>Press to transfer the current message (during playback).</p>   |
|  | <p>Press to change the personal announcement (This option is only available to handset mailboxes).</p>  |
|  | <p>Press to change to the general mailbox (This option is only available to handset mailboxes).</p>   |
|  | <ul style="list-style-type: none"> <li>• Press to end the call.</li> <li>• Press to accept the recorded announcement (during announcement playback).</li> </ul>   |

## Remote access

### 4. Hang up to end the call and save all undeleted messages.

Cut out the remote access wallet card at the back of this user's manual for quick reference.



#### **NOTES:**

1. If you do not enter a valid remote access code, the system ignores your entering and continues the call.
2. If you pause for more than four seconds during remote access, you hear a help menu listing all features and commands. If there is no command for another 20 seconds, the call ends automatically.
3. If you want to delete all the old messages remotely, press 3 twice in remote standby mode.
4. If the memory is full, the answering system answers after 10 rings and announces, "*Memory is full. Enter the remote access code.*" Enter your remote access code to access the messages and announcements.

## Cordless headset operation

To register and deregister an AT&T compatible DECT 6.0 cordless headset (AT&T TL7600/7610/7611 model) at the SB67118 telephone base, please refer to the pages X-X. To view the TL7610/7611/7600 model manual, visit our website at [www.telephones.att.com](http://www.telephones.att.com), or call **1 (800) 222-3111**. In Canada dial **1 (866) 288-4268**.

### Number the cordless headset

A cordless headset is numbered as extension 10 after the registration, regardless of how many handsets have already been registered to the base..

By pressing the **ON/OFF** button on the cordless headset, you can see the extension indicator  on the telephone base screen.

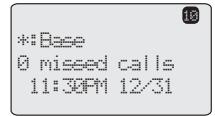

### Make a call

You can make a call by using a registered cordless headset and the dial pad at the telephone base.

- **To make a call:**

1. Press **ON/OFF** button on the cordless headset.

**-OR-**

Press **ON/OFF** button on the cordless headset, then press the **LINE (1-4)** key for the desired line to override automatic line selection.

2. Wait for a dial tone. The **HEADSET** indicator on the telephone base turns on. You can enter the telephone number and the screen displays the elapsed time as you talk (in hours, minutes and seconds).

- **To end a call:**

Press **ON/OFF** button again on the cordless headset to hang up.

**-OR-**

Press the **HEADSET** key on the telephone base to hang up.

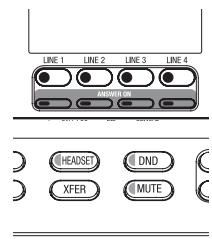
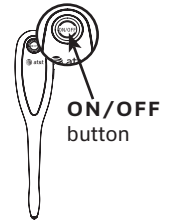

**NOTE:** The elapsed time is not affected by accessing services from your local telephone service provider.

## Cordless headset operation

### **Answer a call**

---

#### **To answer a call**

- Press the **ON/OFF** button on the cordless headset. The **HEADSET** indicator on the telephone base turns on.

#### **To end a call:**

- Press the **ON/OFF** button again on the cordless headset to hang up.

**-OR-**

Press the **HEADSET** key on the telephone base to hang up.

## Options while on calls

### Volume control

---

#### To adjust the listening volume:

While on a call, press the **VOLUME**  + / - keys on the side of the headset to adjust the listening volume.

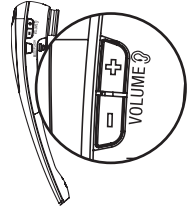

#### To adjust the speaking volume:

While on a call, press the **VOLUME**    keys on the side of the headset base to adjust the speaking volume.

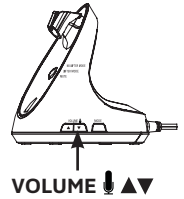

**NOTE:** When the volume reaches the minimum or maximum setting, you hear three quick beeps.

### Switch between corded or cordless handset, speakerphone and cordless headset

---

#### Switch from corded or cordless handset to cordless headset

- During a call, press the **HEADSET** key on the telephone base. You can hear a dial tone on the cordless headset.

#### Switch from cordless headset to corded or cordless handset

- During a call, lift the corded handset on the telephone base or press  **PHONE/FLASH** on the cordless handset.

#### Switch from speakerphone to cordless headset

- During a call, press the **HEADSET** key on the telephone base. You can hear a dial tone on the cordless headset.

#### Switch from cordless headset to speakerphone

- During a call, press  **SPEAKER** on the telephone base. The **HEADSET** indicator on the telephone base turns off.



## Options while on calls

### Call waiting

---

If you subscribe to call waiting service with your local telephone service provider, you hear a beep from the earpiece of the cordless headset if you receive an incoming call while you are already on a call using the cordless headset.

- Press the **MUTE/FLASH** button on the cordless headset to put your current call on hold and take the new call.
- Press the **MUTE/FLASH** at any time to switch back and forth between calls.

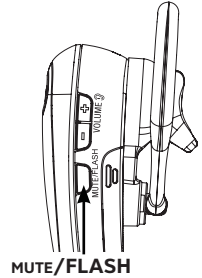

### Answer a call from another line

---

You can answer a call from another line while using the cordless headset during a call.

- During a call, press the desired **LINE (1-4)** key to answer another call. Your current call is put on hold.
- Press the desired **LINE (1-4)** key to retrieve the original call. Your current call is put on hold.

### Hold

---

You can mute a call by pressing the **MUTE/FLASH** key during a conversation to silence the microphone of the cordless headset. You can hear the caller from the cordless headset, but the caller does not hear you.

### Join in

---

You can join in an ongoing call on another extension handset when the call privacy is not set on that handset.

- Press **ON/OFF** button on the cordless headset. You can hear a dial tone.
- Press and hold the desired **LINE (1-4)** key to join in the call.

#### **-OR-**

- Press and hold the desired **LINE (1-4)** key on the telephone base to join in the call.
- Press **HEADSET** on the telephone base to switch to the cordless headset.

## Options while on calls

### Conference calls

---

You can use cordless headset to join in a conference call.

#### Start a conference call

- While using cordless headset to make or answer a call, press **HOLD** to put the current call on hold.
- Enter a new telephone number, then press **LINE (1-4)** key to call someone on another line, or press the desired one-touch key to start an intercom connection.
- When this call or intercom is answered, press **CONF** on the telephone base. The three-party conference begins immediately.

#### Join a conference call

- Press the **HEADSET** key on the telephone base to join the conference call.



**NOTE:** Please refer to Three-way conference call on page X 45 for detailed conference call operation..

### Intercom calls

---

You can make or answer an intercom call with the cordless headset.

#### Make an intercom call

- Press the **HEADSET** key on the telephone base or press the **ON/OFF** button on the cordless headset. You can hear a dial tone.
- Press the one-touch key for the detination party. The screen displays **Calling X: Handset X** (**X** represents the extension and handset number).

#### -OR-

- The user can initiate the intercom using the speakerphone/corded handset and then switch to headset mode by pressing the **HEADSET** key on the telephone base, or by pressing the **ON/OFF** button on the cordless headset.
- It is also possible to the initiate intercom when the telephone base is off-hook and the cordless headset is in use. The procedure is the same as with the speakerphone/corded handset mode.

## Options while on calls



**NOTES:**

1. Before the destination party answers the intercom call, press the corresponding LINE (1-4) key to resume the call.
2. The intercom call automatically ends if the destination party does not answer it for 1 minute.f

# Telephone base display screen messages

|   |  |
|---|--|
| Call log empty  |  |
| Place handset in cradle and press INT on base for 4 seconds to register handset |  |
| Handset registering   |  |
| Handset registered  |  |
| Calling<br>1: Handset 1   |  |
| Directory empty   |  |
| Cordless headset registering  |  |
| Cordless headset registered   |  |
| Memory is full  |  |
| Incoming call<br>—Line X—   |  |
| Intercom to:  |  |
| XX missed calls   |  |
| Busy  |  |
| Deregistering   |  |
| All handsets deregistered   |  |
| Auto Attendant ON<br>Play announcement  |  |
| Alert call #. . #   |  |
| COUM reset  |  |
| Deleted   |  |
| Privacy   |  |
| Msg. transferred to mailbox X   |  |
| All erased.   |  |
|   |  |

## Telephone base display screen messages

# Maintenance

## **Taking care of your telephone**

- Your telephone base contains sophisticated electronic parts, so you must treat it with care.
- Avoid rough treatment.
- Place the corded handset down gently.
- Save the original packing materials to protect your telephone base if you ever need to ship it.

## **Avoid water**

- You can damage your telephone base if it gets wet. Do not use the corded handset in the rain, or handle it with wet hands. Do not install the telephone base near a sink, bathtub or shower.

## **Electrical storms**

- Electrical storms can sometimes cause power surges harmful to electronic equipment. For your own safety, take caution when using electric appliances during storms.

## **Cleaning your telephone**

- Your telephone base has a durable plastic casing that should retain its luster for many years. Clean it only with a soft cloth slightly dampened with water or a mild soap.
- Do not use excess water or cleaning solvents of any kind.

Remember that electrical appliances can cause serious injury if used when you are wet or standing in water. If the telephone base should fall into water, DO NOT RETRIEVE IT UNTIL YOU UNPLUG THE POWER CORD AND TELEPHONE LINE CORDS FROM THE WALL. Then pull the unit out by the unplugged cords.

## Important safety information



This symbol is to alert you to important operating or servicing instructions that may appear in this user's manual. Always follow basic safety precautions when using this product to reduce the risk of injury, fire, or electric shock.

### Safety information

---

- Read and understand all instructions in the user's manual. Observe all markings on the product.
- Avoid using a telephone during a thunderstorm. There may be a slight chance of electric shock from lightning.
- Do not use a telephone in the vicinity of a gas leak. If you suspect a gas leak, report it immediately, but use a telephone away from the area where the gas is leaking. If this product is a cordless model, make sure the telephone base is also away from the area.
- Do not use this product near water, or when you are wet. For example, do not use it in a wet basement or shower, or next to a swimming pool, bathtub, kitchen sink, or laundry tub. Do not use liquids or aerosol sprays for cleaning. If the product comes in contact with any liquid, unplug any line or power cord immediately. Do not plug the product back in until it has dried thoroughly.
- Install this product in a protected location where no one can trip over any line or power cords. Protect cords from damage or abrasion.
- If this product does not operate normally, see the **Troubleshooting** section on pages X-X of this user's manual. If you cannot solve the problem, or if the product is damaged, refer to the **Limited warranty** on X-X. Do not open this product except as directed in your user's manual. Opening the product or reassembling it incorrectly may expose you to hazardous voltages or other risks.
- Replace batteries only as described in your user's manual. Do not burn or puncture batteries — they contain caustic chemicals.
- This power adapter is intended to be correctly oriented in a vertical or floor mount position. The prongs are not designed to hold the plug in place if it is plugged into a ceiling or an under-the-table/cabinet outlet.



**Caution:** Use only the power adapter provided with this product. To obtain a replacement, visit our website at **[www.telephones.att.com](http://www.telephones.att.com)** or call **1 (800) 222-3111**. In Canada, dial **1 (866) 288-4268**.

# Important safety information

## **Especially about cordless telephones**

---

- **Electrical power:** The telephone base must be connected to a working electrical outlet. The electrical outlet should not be controlled by a wall switch. Calls cannot be made from the handset if the telephone base is unplugged or switched off, or if the electrical power is interrupted.
- **Power adapter:** The power adapter is intended to be correctly oriented in a vertical or floor mount position. The prongs are not designed to hold the plug in place if it is plugged into a ceiling, under-the-table or cabinet outlet.

## **Precautions for users of implanted cardiac pacemakers**

---

Cardiac pacemakers (applies only to digital cordless telephones):

Wireless Technology Research, LLC (WTR), an independent research entity, led a multidisciplinary evaluation of the interference between portable wireless telephones and implanted cardiac pacemakers. Supported by the U.S. Food and Drug Administration, WTR recommends to physicians that:

### **Pacemaker patients**

---

Should keep wireless telephones at least six inches from the pacemaker.

Should NOT place wireless telephones directly over the pacemaker, such as in a breast pocket, when it is turned ON.

Should use the wireless telephone at the ear opposite the pacemaker.

WTR's evaluation did not identify any risk to bystanders with pacemakers from other persons using wireless telephones.

## **Especially about telephone answering systems**

---

**Two-way recording:** This unit does not sound warning beeps to inform the other party that the call is being recorded. To ensure that you are in compliance with any federal or state regulations regarding recording a telephone call, you should start the recording process and then inform the other party that you are recording the conversation.

# **SAVE THESE INSTRUCTIONS**



## FCC part 68 and ACTA

This equipment complies with Part 68 of the FCC rules and with technical requirements adopted by the Administrative Council for Terminal Attachments (ACTA). The label on the back or bottom of this equipment contains, among other things, a product identifier in the format US: AAAEQ##TXXXX. This identifier must be provided to your local telephone company upon request.

The plug and jack used to connect this equipment to premises wiring and the telephone network must comply with the applicable Part 68 rules and technical requirements adopted by ACTA. A compliant telephone cord and modular plug is provided with this product. It is designed to be connected to a compatible modular jack that is also compliant. An RJ11 jack should normally be used for connecting to a single line and an RJ14 jack for two lines. See Installation Instructions in the user's manual.

The Ringer Equivalence Number (REN) is used to determine how many devices you may connect to your telephone line and still have them ring when you are called. The REN for this product is encoded as the 6th and 7th characters following the US: in the product identifier (e.g., if ## is 03, the REN is 0.3). In most, but not all areas, the sum of all RENs should be five (5.0) or less. For more information, please contact your local telephone company.

This equipment may not be used with Party Lines. If you have specially wired alarm dialing equipment connected to your telephone line, ensure the connection of this equipment does not disable your alarm equipment. If you have questions about what will disable the alarm equipment, consult your telephone company or a qualified installer.

If this equipment is malfunctioning, it must be unplugged from the modular jack until the problem has been corrected. Repairs to this telephone equipment can only be made by the manufacturer or its authorized agents. For repair procedures, follow the instructions outlined under the Limited Warranty.

If this equipment is causing harm to the telephone network, the telephone company may temporarily discontinue your telephone service. The telephone company is required to notify you before interrupting service. If advance notice is not practical, you will be notified as soon as possible. You will be given the opportunity to correct the problem and the telephone company is required to inform you of your right to file a complaint with the FCC. Your telephone company may make changes in its facilities, equipment, operation, or procedures that could affect the proper functioning of this product. The telephone company is required to notify you if such changes are planned.

If this product is equipped with a corded or cordless handset, it is hearing aid compatible.

If this product has memory dialing locations, you may choose to store emergency telephone numbers (e.g., police, fire, medical) in these locations. If you do store or test emergency numbers, please:

Remain on the line and briefly explain the reason for the call before hanging up.

Perform such activities in off-peak hours, such as early morning or late evening.

### **Industry Canada**

Operation is subject to the following two conditions: (1) this device may not cause harmful interference, and (2) this device must accept any interference, including interference that may cause undesired operation.

The term "IC:" before the certification/registration number only signifies that the Industry Canada technical specifications were met.

The Ringer Equivalence Number (REN) for this terminal equipment is 0.1. The REN is an indication of the maximum number of devices allowed to be connected to a telephone interface. The termination on an interface may consist of any combination of devices subject only to the requirement that the sum of the RENs of all the devices does not exceed five.

This product meets the applicable Industry Canada technical specifications.

## FCC part 15

This equipment has been tested and found to comply with the requirements for a Class B digital device under Part 15 of the Federal Communications Commission (FCC) rules. These requirements are intended to provide reasonable protection against harmful interference in a residential installation. This equipment generates, uses and can radiate radio frequency energy and, if not installed and used in accordance with the instructions, may cause harmful interference to radio communications. However, there is no guarantee that interference will not occur in a particular installation. If this equipment does cause harmful interference to radio or television reception, which can be determined by turning the equipment off and on, the user is encouraged to try to correct the interference by one or more of the following measures:

- Reorient or relocate the receiving antenna.
- Increase the separation between the equipment and receiver.
- Connect the equipment into an outlet on a circuit different from that to which the receiver is connected.
- Consult the dealer or an experienced radio/TV technician for help.

Changes or modifications to this equipment not expressly approved by the party responsible for compliance could void the user's authority to operate the equipment.

This device complies with Part 15 of the FCC Rules. Operation is subject to the following two conditions: (1) this device may not cause harmful interference, and (2) this device must accept any interference received, including interference that may cause undesired operation. Privacy of communications may not be ensured when using this telephone.

To ensure safety of users, the FCC has established criteria for the amount of radio frequency energy that can be safely absorbed by a user or bystander according to the intended usage of the product. This product has been tested and found to comply with the FCC criteria. The handset may be safely held against the ear of the user. The telephone base shall be installed and used such that parts of the user's body other than the hands are maintained at a distance of approximately 20 cm (8 inches) or more. **If you choose to use a clipping device, please make sure to only use the supplied AT&T belt clip.**

This Class B digital apparatus complies with Canadian ICES-003.

## Limited warranty

The AT&T brand is used under license - any repair, replacement or warranty service, and all questions about this product should be directed to: In the United States of America, visit **www.telephones.att.com** or call **1 (800) 222-3111**. In Canada, call **1 (866) 288-4268**.

### 1. What does this limited warranty cover?

The manufacturer of this AT&T-branded product warrants to the holder of a valid proof of purchase ("CONSUMER" or "you") that the product and all accessories provided in the sales package ("PRODUCT") are free from defects in material and workmanship, pursuant to the following terms and conditions, when installed and used normally and in accordance with the PRODUCT operating instructions. This limited warranty extends only to the CONSUMER for products purchased and used in the United States of America and Canada.

### 2. What will be done if the PRODUCT is not free from defects in materials and workmanship during the limited warranty period ("materially defective PRODUCT")?

During the limited warranty period, the manufacturer's authorized service representative will repair or replace at the manufacturer's option, without charge, a materially defective PRODUCT. If the manufacturer repairs the PRODUCT, they may use new or refurbished replacement parts. If the manufacturer chooses to replace the PRODUCT, they may replace it with a new or refurbished PRODUCT of the same or similar design. The manufacturer will retain defective parts, modules, or equipment. Repair or replacement of the PRODUCT, at the manufacturer's option, is your exclusive remedy. The manufacturer will return repaired or replacement products to you in working condition. You should expect the repair or replacement to take approximately 30 days.

### 3. How long is the limited warranty period?

The limited warranty period for the PRODUCT extends for ONE (1) YEAR from the date of purchase. If the manufacturer repairs or replaces a materially defective PRODUCT under the terms of this limited warranty, this limited warranty also applies to repaired or replacement PRODUCT for a period of either (a) 90 days from the date the repaired or replacement PRODUCT is shipped to you or (b) the time remaining on the original one-year limited warranty; whichever is longer.

### 4. What is not covered by this limited warranty?

This limited warranty does not cover:

- PRODUCT that has been subjected to misuse, accident, shipping or other physical damage, improper installation, abnormal operation or handling, neglect, inundation, fire, water, or other liquid intrusion; or
- PRODUCT that has been damaged due to repair, alteration, or modification by anyone other than an authorized service representative of the manufacturer; or
- PRODUCT to the extent that the problem experienced is caused by signal conditions, network reliability or cable or antenna systems; or
- PRODUCT to the extent that the problem is caused by use with non-AT&T accessories; or
- PRODUCT whose warranty/quality stickers, PRODUCT serial number plates or electronic serial numbers have been removed, altered or rendered illegible; or
- PRODUCT purchased, used, serviced, or shipped for repair from outside the United States of America or Canada, or used for commercial or institutional purposes (including but not limited to products used for rental purposes); or
- PRODUCT returned without valid proof of purchase (see item 6 below); or
- Charges for installation or setup, adjustment of customer controls, and installation or repair of systems outside the unit.

## Limited warranty

### 5. How do you get warranty service?

To obtain warranty service in the United States of America, visit

**www.telephones.att.com** or call **1 (800) 222-3111**. In Canada, call **1 (866) 288-4268**. NOTE: Before calling for service, please review the user's manual; a check of the PRODUCT controls and features may save you a service call.

Except as provided by applicable law, you assume the risk of loss or damage during transit and transportation and are responsible for delivery or handling charges incurred in the transport of the PRODUCT(s) to the service location. The manufacturer will return repaired or replaced PRODUCT under this limited warranty to you. Transportation, delivery or handling charges are prepaid. The manufacturer assumes no risk for damage or loss of the PRODUCT in transit. If the PRODUCT failure is not covered by this limited warranty, or proof of purchase does not meet the terms of this limited warranty, the manufacturer will notify you and will request that you authorize the cost of repair prior to any further repair activity. You must pay for the cost of repair and return shipping costs for the repair of products that are not covered by this limited warranty.

### 6. What must you return with the PRODUCT to get warranty service? You must:

- Return the entire original package and contents including the PRODUCT to the service location along with a description of the malfunction or difficulty; and
- Include "valid proof of purchase" (sales receipt) identifying the PRODUCT purchased (PRODUCT model) and the date of purchase or receipt; and
- Provide your name, complete and correct mailing address, and telephone number.

### 7. Other limitations

This warranty is the complete and exclusive agreement between you and the manufacturer of this AT&T branded PRODUCT. It supersedes all other written or oral communications related to this PRODUCT. The manufacturer provides no other warranties for this PRODUCT. The warranty exclusively describes all of the manufacturer's responsibilities regarding the PRODUCT. There are no other express warranties. No one is authorized to make modifications to this limited warranty and you should not rely on any such modification.

State/Provincial Law rights: This warranty gives you specific legal rights, and you may also have other rights which vary from state to state or province to province.

Limitations: Implied warranties, including those of fitness for a particular purpose and merchantability (an unwritten warranty that the PRODUCT is fit for ordinary use) are limited to one year from date of purchase. Some states/provinces do not allow limitations on how long an implied warranty lasts, so the above limitation may not apply to you. In no event shall the manufacturer be liable for any indirect, special, incidental, consequential, or similar damages (including, but not limited to lost profits or revenue, inability to use the PRODUCT or other associated equipment, the cost of substitute equipment, and claims by third parties) resulting from the use of this PRODUCT. Some states/provinces do not allow the exclusion or limitation of incidental or consequential damages, so the above limitation or exclusion may not apply to you.

**Please retain your original sales receipt as proof of purchase.**

## Technical specifications

|   |                             |
|---|-----------------------------|
| RF frequency band                               | 1921.536 MHz — 1928.448 MHz |
| Channels  | 5                           |
| Operating temperature                           | 32°F — 122°F<br>0°C — 50°C  |
| Telephone base voltage<br>(AC voltage, 50/60Hz) | 100 — 240 Vrms              |
| Telephone base voltage<br>(AC adapter output)   | 8VDC @1000mA                |
| Headset jack                                    | 2.5mm, 32-150ohm            |

### **DECT 6.0 digital technology**

The AT&T DECT 6.0 products offer unsurpassed range performance and sound clarity. This is achieved through a unique antenna design and advances in noise-filtering technology. An independent laboratory has confirmed that AT&T DECT 6.0 products perform up to 45% better in range competitions. Now calls can be taken in the basement, backyard and garage with exceptional sound quality.

### **Telephone operating range**

This cordless telephone operates within the maximum power allowed by the Federal Communications Commission (FCC). Even so, this handset and telephone base can communicate over only a certain distance — which can vary with the locations of the telephone base and handset, the weather, and the construction of your home or office.

### **Redefining long range coverage and clarity**

This telephone base comes with two antennas which give much better clarity and cover a longer range than before.

## Troubleshooting

If you have difficulty with your phone, please try the suggestions below. For Customer Service, visit our website at **www.telephones.att.com** or call **1 (800) 222-3111**. In Canada, dial **1 (866) 288-4268**.

My telephone base doesn't work at all.

- Make sure the power cord is securely plugged in.
  - Make sure you plug the telephone line cord securely and firmly into the telephone base and the telephone wall jack.
  - Reset the telephone base. Unplug the electrical power. Wait for approximately 15 seconds, then plug it back in. Allow up to one minute for the telephone base to reset.
  - You may need to purchase four AA alkaline batteries as backup battery to make the telephone base work in the event of a power failure. Please refer to **Optional backup battery installation** in this user's manual.
- 

I cannot get a dial tone from the corded handset.

- First try all the suggestions above.
  - Make sure you plug the handset cord securely and firmly into the **HANDSET** jack on the telephone base and the corded handset.
  - If the previous suggestions do not work, disconnect the telephone base from the telephone jack and connect to a different phone. If there is no dial tone on that phone either, the problem is in your wiring or local service. Contact your local telephone service provider.
  - Your line cord might be malfunctioning. Try installing a new line cord.
- 

I cannot dial out.

- First try all the suggestions above.
- Make sure you have a dial tone before dialing. The corded handset might take a second or two to connect the telephone base and produce a dial tone. This is normal. Wait an extra second before dialing.
- Eliminate any background noise. Noise from a television, radio or other appliances might cause the phone to not dial out properly. If you cannot eliminate the background noise, first try muting the corded handset before dialing, or dialing from another room by a cordless handset with less background noise.

## Troubleshooting

- If the other phones in your home are having the same problem, contact your local telephone company (charges might apply).
- 

My telephone base isn't performing normally.

- Make sure you plug the power cord securely into the telephone base. Plug the power adapter into a different, working electrical outlet without a wall switch.
  - Reset the telephone base. Unplug the electrical power. Wait for 15 seconds then plug it back in. Allow up to one minute for the telephone base to reset.
  - Other electronic products can cause interference to your telephone base. Try installing your telephone base as far away from these types of electronic devices as possible: television sets, VCRs, or other cordless telephones.
- 

I get noise, static, or weak signals even when I'm near the telephone base.

- If you subscribe to high-speed Internet service (digital subscriber line - DSL) through your telephone lines, you must install a DSL filter between the telephone base and the telephone wall jack. The filter prevents noise and caller ID problems as a result of DSL interference. Please contact your DSL service provider for more information about DSL filters.
- You may be able to improve the performance of your telephone base by installing your new telephone base as far as possible from any other existing corded or cordless telephone system that may already be installed.
- Other electronic products can cause interference to your telephone base. Try installing your telephone base as far away from the following electronic devices as possible: television sets, VCRs, or other cordless telephones.
- Do not install this telephone base near a microwave oven or on the same electrical outlet. You might experience decreased performance while the microwave oven is operating.
- If you plug your telephone in with a modem or a surge protector, plug the telephone base (or modem/surge protector) into a different location. If this does not solve the problem, re-locate your telephone base

# Troubleshooting

or modem farther apart from one another, or use a different surge protector.

- Relocate your phone to a higher location. The phone might have better reception in a high area.
- If the other phones in your home are having the same problem, contact your local telephone company (charges may apply).

---

I experience poor sound quality when using the speakerphone.

- For increased sound quality while using the telephone speakerphone, place the telephone base on a flat surface with the dial pad facing up.
- Excessive background noise will cause a speakerphone to fade in and out. Try controlling the background noise by turning off any audio devices near the speakerphone. Also, try to avoid interrupting the person at the other end of the conversation while they are speaking. If background noise cannot be controlled, you should stop speakerphone operation and return to normal corded handset mode.
- When using a speakerphone, controlling background noise in your environment is essential. While you are listening to your party, press **MUTE** to temporarily turn your microphone off. When it is your turn to speak, remember to press **MUTE** again to turn the microphone on.

---

I hear other calls while using my phone.

- Disconnect the telephone base from the telephone jack, and plug in a different telephone. If you still hear other calls, call your local telephone service provider.

---

My telephone base does not ring when I receive a call.

- Make sure that the ringer is not off. Refer to the section on ringer selection in this user's manual.
- Make sure you plug in the telephone line cord securely into the telephone base and the telephone jack. Make sure you plug in the power cord securely.
- You may have too many extension phones on your telephone line to allow all of them to ring simultaneously. Try unplugging some of the other phones.
- If the other phones in your home are having the same problem, contact your local telephone service provider (charges might apply).



## Troubleshooting

- Test a working phone at the phone jack. If another phone has the same problem, contact your local telephone service provider (charges might apply).
- Other electronic products can cause interference with your telephone base. Try installing your telephone base as far away as possible from electronic devices such as television sets, VCRs, or other cordless telephones.
- Your line cord might be malfunctioning. Try installing a new line cord.

---

My calls cut in and out while I'm using my corded handset.

- Other electronic products can cause interference with your telephone base. Try installing your telephone base as far away from the following electronic devices as possible: television sets, VCRs, or other cordless telephones.
- Do not install this telephone base near a microwave oven or on the same electrical outlet. You might experience decreased performance while the microwave oven is operating.
- If you plug your telephone base in with a modem or surge protector, plug the telephone base (or modem/surge protector) into a different location. If this does not solve the problem, re-locate your telephone base or modem farther apart from one another, or use a different surge protector.
- Relocate your telephone base to a higher location. The telephone base might have better reception when installed in a high area.
- If the other phones in your home are having the same problem, contact your local telephone service provider (charges may apply).
- Excessive background noise will cause a speakerphone to fade in and out. Try controlling the background noise by turning off any audio devices near the speakerphone. Also, try to avoid interrupting the person at the other end of the conversation while they are speaking. If background noise cannot be controlled, you should stop speakerphone operation and return to normal handset mode.
- When using a telephone base speakerphone, controlling background noise in your environment is essential. While you are listening to your party, press

# Troubleshooting

**MUTE** to temporarily turn your microphone off. When it is your turn to speak, remember to press **MUTE** again to turn the microphone on.

---

My caller ID isn't working.

- Caller ID is a subscription service. You must subscribe to this service from your local telephone service provider for this feature to work on your telephone base.
  - The caller must be calling from an area that supports caller ID.
  - Both you and your caller's telephone service providers must use caller ID compatible equipment.
  - If you subscribe to high-speed Internet service (digital subscriber line - DSL) through your telephone lines, you must install a DSL filter between the telephone base and the telephone wall jack. The filter prevents noise and caller ID problems resulting from DSL interference. Please contact your DSL service provider for more information about DSL filters.
- 

System does not receive caller ID when on a call.

- Make sure you subscribe to caller ID with call waiting features from your local telephone service provider. Caller ID features works only if both you and the caller are in areas offering caller ID service, and if both telephone companies use compatible equipment.
- 

The answering system is recording incomplete messages.

- If a caller leaves a very long message, part of it may be lost when the system disconnects the call after **four** minutes.
- If the caller pauses for longer than **seven** seconds, the system stops recording and disconnects the call.
- If the system's memory becomes full during a message, the system stops recording and disconnects the call.
- If the caller's voice is very soft, the system may stop recording and disconnects the call.

## Troubleshooting

I have difficulty hearing messages.

- Press **VOL+** to increase the speaker volume on the telephone base.
- 

System does not answer after correct number of rings.

- Make sure that the answering system is on (pages X-X).
  - If toll saver is activated, the number of rings changes to two when you have new messages stored (page X).
  - If the memory is full or the system is off, the system will answer after 10 rings.
- 

System does not respond to remote commands.

- Make sure to enter your remote access code correctly (page 61 ).
  - Make sure you are calling from a touch-tone phone. When you dial a number, you should hear tones. If you hear clicks, the phone is not a touch-tone telephone and cannot activate the answering system.
  - The answering system may not detect the remote access code while your announcement is playing. Try waiting until the announcement is over before entering the code.
  - There may be interference on the phone line you are using. Press dial pad keys firmly.
- 

System does not record messages.

- Make sure the answering system is on (pages 19 & 55).
- Make sure the memory of the answering system is not full. Please refer to the **Remaining space** section in the User's manual.
- If you have voicemail service in addition to your answering system, your callers' messages may be going into voicemail before your answering system picks up the call. Program your voicemail to pick up at least two rings greater than the number of rings your answering system is set to answer the call. See **Answering system** on page 55 for more information.

## Troubleshooting

Outgoing announcement is not clear.

- When you record your announcement, make sure you speak in a normal tone of voice, about nine inches from the telephone base.
- Make sure there is no background noise (TV, music, etc.) while recording.

---

Common cure for electronic equipment.

If the telephone base does not seem to be responding normally, do the following (in the order listed):

- Disconnect the power to the telephone base.
- Disconnect the spare battery, if applicable.
- Wait a few minutes.
- Connect power to the telephone base.
- Re-install the backup battery.
- Wait for re-establishing the connection with the telephone base. Allow up to one minute for this to take place.

Index

Index



[www.telephones.att.com](http://www.telephones.att.com)