

vtech®

Innovation Beyond Technology™

Online user's manual

www.vtechphones.com



Models:
CS6419/CS6419-2

DECT 6.0

Congratulations

on purchasing your new VTech product. Before using this telephone, please read **Important safety instructions** on pages 47-48 of this manual.

This manual has all the feature operations and troubleshooting necessary to install and operate your new VTech telephone. Please review this manual thoroughly to ensure proper installation and operation of this innovative and feature rich VTech product. For support, shopping, and everything new at VTech, visit our website at www.vtechphones.com. In Canada, please visit www.vtechcanada.com.



The ENERGY STAR[®] program (www.energystar.gov) recognizes and encourages the use of products that save energy and help protect our environment. We are proud to mark this product with the ENERGY STAR[®] label indicating it meets the latest energy efficiency guidelines.



Telephones identified with this logo have reduced noise and interference when used with most T-coil equipped hearing aids and cochlear implants. The TIA-1083 Compliant Logo is a trademark of the Telecommunications Industry Association. Used under license.

Table of contents

Getting started	1	Join a call in progress.....	18
Parts checklist	1	Find handset.....	18
Telephone base and charger installation	2	Redial list.....	19
Battery installation	3	Review and dial a redial entry	19
Battery charging	4	Store a number from the redial list to the directory	19
Installation options.....	5	Delete a redial entry	19
Telephone base layout	7	Intercom.....	20
Handset layout	8	Answer an incoming call during an intercom call.....	21
Telephone settings	10	Call transfer using intercom.....	21
Using the menu	10	Directory	23
Ringer volume	10	About directory	23
Ringer tone.....	11	Create a new directory entry	24
LCD language.....	11	Review the directory	26
Clear voicemail indicators.....	12	Alphabetical search	26
Key tone	13	Dial a directory entry.....	26
Set date and time	13	Edit a directory entry.....	26
Home area code	14	Delete a directory entry	27
Dial mode	14	Speed dial.....	27
Telephone operation	15	Store a speed dial entry.....	27
Make a call	15	Dial a speed dial number.....	28
Predial a call	15	Delete a speed dial entry.....	28
Answer a call	15	Caller ID	29
End a call.....	15	About caller ID	29
Speakerphone	15	Information about caller ID with call waiting.....	29
Volume	15	Call log.....	30
Mute.....	16	Missed call indicator	31
Call waiting	16	Memory match.....	31
Temporary ringer silencing	16	Review and dial from the call log....	31
Temporary tone dialing.....	16		
Chain dialing.....	17		

Table of contents

View dialing options.....	32
Save a call log entry to the directory	32
Delete from the call log.....	33
Call log display screen messages ..	33
Appendix	34
Handset display screen messages	34
Handset and telephone base indicators	36
Battery	37
Expand your telephone system	38
Add and register a handset (optional)	38
Replace a handset.....	39
Troubleshooting.....	40
Important safety instructions.....	47
Precautions for users of implanted cardiac pacemakers	48
Operating range.....	48
Maintenance	49
About cordless telephones	50
The RBRC® seal	50
Limited warranty	51
FCC, ACTA and IC regulations	53
Technical specifications.....	55
Index	56

Getting started

Parts checklist

Your telephone package contains the following items. Save your sales receipt and original packaging in case it is necessary to ship your telephone for warranty service.



Battery compartment cover

(1 for CS6419 and
2 for CS6419-2)



Battery

(1 for CS6419 and
2 for CS6419-2)



Telephone line cord

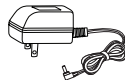

Telephone base power adapter



Handset

(1 for CS6419 and
2 for CS6419-2)

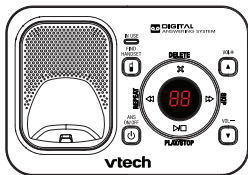

Telephone base

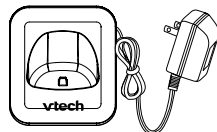

Charger and charger adapter

(1 for CS6419-2)

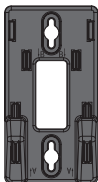

Wall mount bracket



User's manual

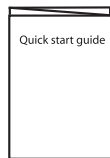

Quick start guide

note

To purchase replacement batteries or power adapters, visit our website at www.vtechphones.com or call 1 (800) 595-9511. In Canada, go to www.vtechcanada.com or call 1 (800) 267-7377.

Getting started

Telephone base and charger installation

Install the telephone base and charger(s) as shown below.

If you subscribe to digital subscriber line (DSL) high-speed Internet service through your telephone line, you must install a DSL filter between the telephone line cord and the telephone wall jack. Contact your DSL service provider for more information about DSL filters.

The telephone base comes ready for tabletop use. If you want to mount your telephone on a wall, refer to **Tabletop to wall mount installation** on page 5 for details.

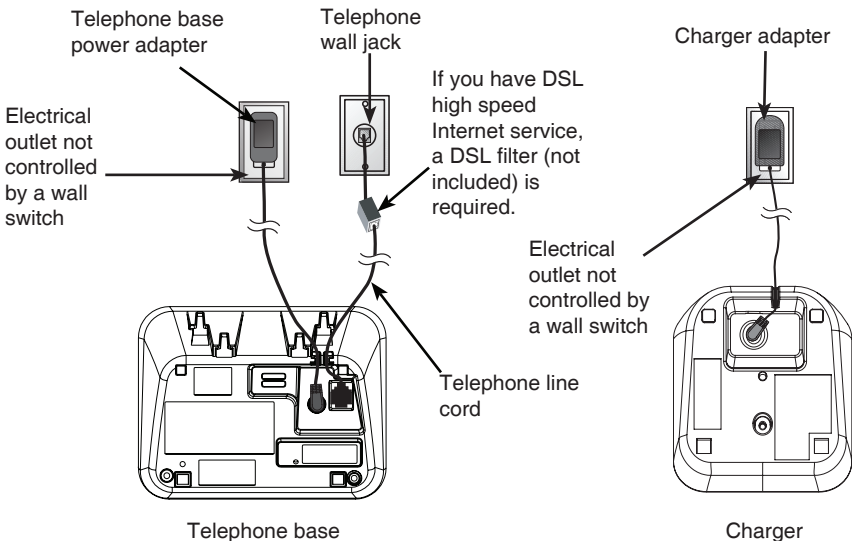

note

- Use only the power adapters supplied with this product. To order a replacement, visit our website at www.vtechphones.com or call 1 (800) 595-9511. In Canada, go to www.vtechcanada.com or dial 1 (800) 267-7377.
- The power adapters are intended to be correctly oriented in a vertical or floor mount position. The prongs are not designed to hold the plug in place if it is plugged into a ceiling, under-the-table or cabinet outlet.



Getting started

Battery charging

Once you have installed the battery, the screen indicates the battery status (see the table below). If necessary, place the handset in the telephone base or charger to charge the battery. For best performance, keep the handset in the telephone base or charger when not in use. The battery is fully charged after 10 hours of continuous charging. See the table on page 37 for battery operating times.

If the screen is blank, you need to charge the handset without interruption for at least 30 minutes to give the handset enough charge to use the telephone for a short time. When the battery is low, the handset plays four short beeps and shows **LOW BATTERY** along with a flashing  icon. When you are on a call in low battery mode, the handset plays four short beeps every 50 seconds.

The following table summarizes the battery charge indicators and actions to take.

Battery indicators	Battery status	Action
The screen is blank.	Battery has no charge and the handset cannot be used.	Charge without interruption (at least 4 minutes).
The screen shows PLACE IN CHARGER and  flashes.	Battery has very little charge and the handset cannot be used.	Charge without interruption until the screen shows HANDSET X (at least 30 minutes).
The screen shows LOW BATTERY and  flashes.	Battery has enough charge to be used for a short time.	Charge without interruption until the screen shows HANDSET X (at least 30 minutes).
The screen shows HANDSET X .	Battery is charged.	To keep the battery charged, place it in the telephone base or charger when not in use.

note

- If you place the handset in the telephone base or charger without plugging in a battery, the screen displays **NO BATTERY**.
- After you install your telephone or power returns following a power outage, the handset will prompt you to set the date and time. For instructions, see Set date/time on page 13. To skip setting the date and time, press **OFF/CANCEL**.

Getting started

Installation options

The telephone comes ready for tabletop use. If you want to mount your telephone on a wall, use the provided wall mount bracket to connect with a standard dual-stud telephone wall mount plate. If you do not have this wall mount plate, you can purchase one from many hardware or consumer electronics retailers. You may need a professional to install the wall mount plate.

Tabletop to wall mount installation

1. Plug one end of the telephone line cord into the **TEL LINE** jack on the bottom of the telephone base. Plug the small end of the base power adapter into the **POWER** jack on the bottom of the telephone base.
2. Position the telephone base against the wall mount bracket. Insert the extend tabs (marked **B**) of the wall mount bracket into the slots on the back of the telephone base. Push the telephone base down until it clicks securely in place.
3. Route the telephone line cord (or DSL) filter through the hole in the middle of the wall mount bracket and plug it into the telephone wall jack. Route the power cord out of the bottom of the telephone and plug it into an electrical outlet not controlled by a wall switch.
4. Align the holes on the bracket with the standard wall mount plate and slide the bracket down until it locks securely. Bundle the telephone line cord and power adapter cord neatly with twist ties.

①

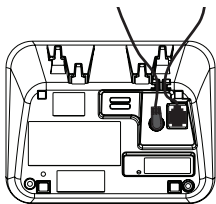

②

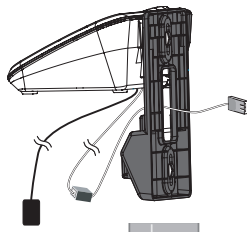

③

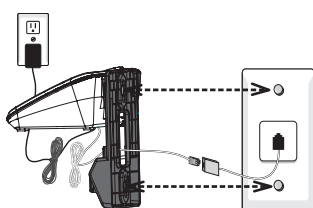

④

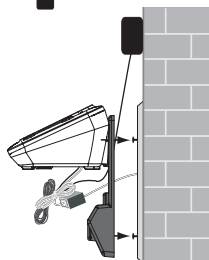

5

Getting started

Installation options (continued)

Wall mount to tabletop installation

1. If the telephone line cord and power adapter cord are bundled, untie them first.
2. Slide the black wall mount bracket up and remove it from the wall mount plate. Unplug the end of the telephone line cord (or DSL filter) from the telephone wall jack. Unplug the power adapter from the power outlet.
3. Slide the telephone base up and remove it from the wall mount bracket.
4. See **Telephone base and charger installation** on page 2.

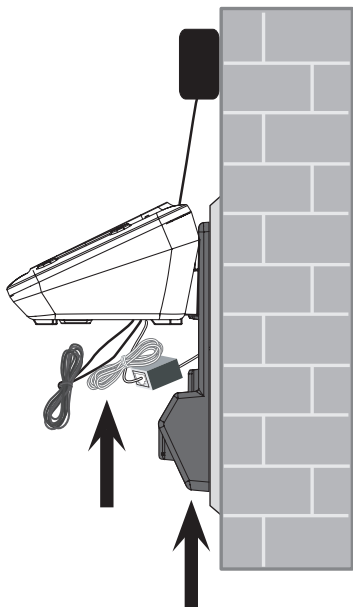

Getting started

Telephone base layout

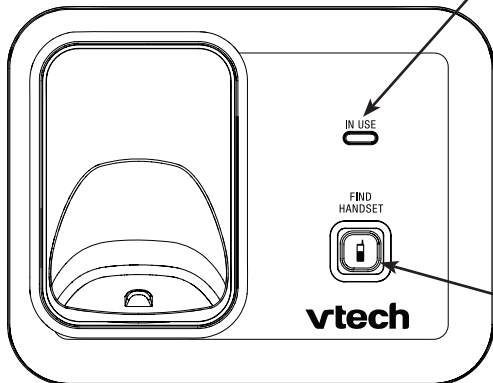

IN USE light

On when the handset is in use.

Flashes quickly when there is an incoming call.

Flashes slowly when another telephone sharing the same line is in use.

FIND HANDSET

Press to page the handset.

Getting started

Handset layout

CHARGE light

On when the handset is charging in the telephone base or charger (page 3).

VOLUME

Press to enter the directory when the telephone is not in use (page 26).

Press to scroll up while in a menu, or in the directory, call log or redial list.

During a call, press to increase the listening volume (page 15).

When entering numbers or names in the directory, press to move the cursor to the right.

MUTE/DELETE

While on a call, press to mute the microphone (page 16).

While using the dialing keys, press to delete digits or characters.

While the handset is ringing, press to silence the ringer temporarily (page 16).

When reviewing redial list, the directory or call log, press to delete the displayed entry (page 19, 27 or 33).

FLASH

Press to make or answer a call (page 15).

During a call, press to answer an incoming call when you receive a call waiting alert (page 16).

1

While reviewing a call log entry, press repeatedly to add or remove 1 in front of the call log entry before dialing or saving it to the directory.

TONEX

Press to switch to tone dialing temporarily when using the pulse service.

(speakerphone)

Press to make or answer a call.

During a call, press to switch between the speakerphone and the handset (page 15).

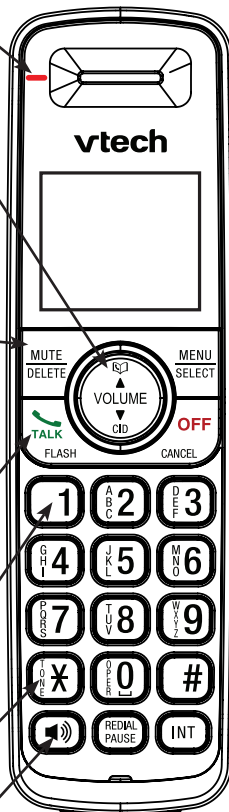

Getting started

Handset layout

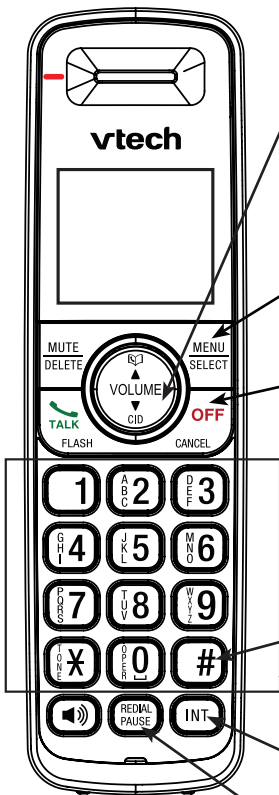

CID▼/VOLUME

Press to review the call log when the telephone is not in use (page 31).

Press to scroll down while in a menu, or in the directory, call log or redial list.

During a call, press to decrease the listening volume (page 15).

When entering numbers or names in the directory, press to move the cursor to the left.

MENU/SELECT

Press to show the menu.

While in a menu, press to select an item, or save an entry or setting.

OFF/CANCEL

During a call, press to hang up.

While the handset is ringing, press to silence the ringer temporarily (page 16).

While the telephone is not in use, press and hold to erase the missed call indicator (page 31).

While in a menu, press to exit to the previous menu or press and hold to exit to idle mode.

(pound key)

Press repeatedly to show other dialing options when reviewing a call log entry (page 32).

Dialing keys

Press to enter numbers or characters.

INT (intercom)

Press to start an intercom conversation or transfer a call (pages 20-22).

REDIAL/PAUSE

Press to review the redial list (page 19).

While dialing or entering numbers into the directory, press and hold to insert a dialing pause.

Telephone settings

Using the menu

In the ringers menu, you can select the ringer tones and adjust the ringer volume for incoming calls.

In the settings menu, you can change and edit the settings for LCD language, voicemail indicators, key tone, date and time, home area code and dial mode.

To enter the handset menu:

1. Press **MENU/SELECT** when the handset is not in use.
2. Press **▼** or **▲** until the screen displays the desired feature menu.
3. Press **MENU/SELECT** to enter that menu.
 - To return to the previous menu, press **OFF/CANCEL**.
 - To return to idle mode, press and hold **OFF/CANCEL**.

Ringer volume

You can adjust the ringer volume or turn the ringer off.

1. Press **MENU/SELECT** when the handset is not in use.
2. Press **▼** or **▲** to select **>RINGERS**, then press **MENU/SELECT**.
3. Press **▼** or **▲** to select **>RINGER VOLUME**, then press **MENU/SELECT**.
4. Press **▼** or **▲** to adjust the volume. A sample of each ringer volume plays as you scroll through the choices.
5. Press **MENU/SELECT** to save your selection. You hear a confirmation tone.

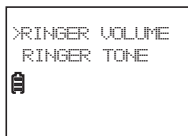
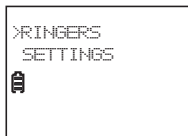

note

- The ringer volume also determines the ringer volume of the intercom calls and the volume of paging tone.
- When the handset ringer volume is set to off, that handset is silenced for all incoming calls and  displays on the handset.
- Unless the ringer volume is turned off on that handset, each handset rings when there is an incoming call.

Telephone settings

Ringer tone

You can choose from different ringer tones.

1. Press **MENU/SELECT** when the handset is not in use.
2. Press ▼ or ▲ to select >**RINGERS**, then press **MENU/SELECT**.
3. Press ▼ or ▲ to select >**RINGER TONE**, then press **MENU/SELECT**.
4. Press ▼ or ▲ to select a desired ringer tone. A sample of each ringer tone plays as you scroll through the choices.
5. Press **MENU/SELECT** to save your selection. You hear a confirmation tone.

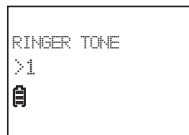
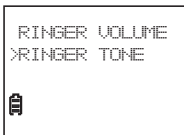

note

If you turn off the handset ringer volume, you will not hear ringer tone samples.

LCD language

You can select a language (English, French or Spanish) to be used in all screen displays.

1. Press **MENU/SELECT** when the handset is not in use.
2. Press ▼ or ▲ to select >**SETTINGS**, then press **MENU/SELECT**.
3. Press ▼ or ▲ to select >**LCD LANGUAGE**, then press **MENU/SELECT**.
4. Press ▼ or ▲ to choose **ENGLISH, FRANÇAIS** or **ESPAÑOL**.
5. Press **MENU/SELECT** to save your selection. You hear a confirmation tone.

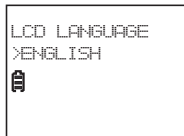
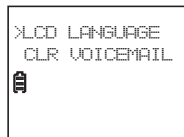

Telephone settings

Clear voicemail indicators

If you subscribe to voicemail service offered by your telephone service provider, **NEW VOICEMAIL** and  appear on the handset when you have new voicemail messages. Contact your telephone service provider for more information about using your voicemail service.

After you have listened to all new voicemail messages, the indicators on the handset turn off automatically.

Use this feature when the telephone indicates that there is new voicemail but there are none (for example, when you have accessed your voicemail while away from home). This feature only turns off the indicators, it does not delete your voicemail messages. As long as you have new voicemail messages, your telephone service provider continues to send the signal to turn on the indicators.

To manually turn off these indicators:

1. Press **MENU/SELECT** when the handset is not in use.
2. Press **▼** or **▲** to select **>SETTINGS**, then press **MENU/SELECT**.
3. Press **▼** or **▲** to select **>CLR VOICEMAIL**, then press **MENU/SELECT**. The screen shows **TURN OFF INDICATOR?**
4. Press **MENU/SELECT** to save your selection. You hear a confirmation tone.



note

Your telephone service provider may alert you of new messages with a stutter (broken) dial tone. Contact your telephone service provider for details.

Telephone settings

Key tone

You can turn the key tone on or off.

1. Press **MENU/SELECT** when the handset is not in use.
2. Press **▼** or **▲** to select **>SETTINGS**, then press **MENU/SELECT**.
3. Press **▼** or **▲** to select **>KEY TONE**, then press **MENU/SELECT**.
4. Press **▼** or **▲** to choose **ON** or **OFF**.
5. Press **MENU/SELECT** to save your selection. You hear a confirmation tone.

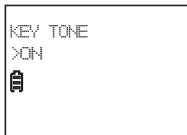
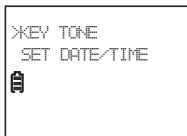

Set date and time

The answering system announces the date and time of each message prior to playing it. If you subscribe to caller ID service, the day, month and time are set automatically with each incoming call. However, the year must be correct so that the day of the week can be calculated from the caller ID information. Before using the answering system, set the date and time.

1. Press **MENU/SELECT** when the handset is not in use.
2. Press **▼** or **▲** to select **>SETTINGS**, then press **MENU/SELECT**.
3. Press **▼** or **▲** to select **>SET DATE/TIME**, then press **MENU/SELECT**.
4. When the month is flashing, press **▼** or **▲** until the screen displays the correct month. Press **MENU/SELECT** to confirm.
-OR-
Press the dialing keys (**0-9**) to enter the current month (for example, if the month is March, you must enter **03**).
5. Repeat Step 4 to set the correct date and year and then press **MENU/SELECT** to advance to set the time.
6. Repeat Step 4 until the time is set. Press **▼** or **▲** to choose **AM** or **PM**. Press **MENU/SELECT** to save your selection. You hear a confirmation tone.

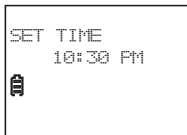
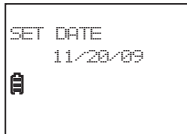
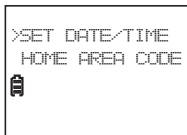

Telephone settings

Home area code

If you dial your local calls using only seven digits (area code not required), you can program your home area code so that when you receive a call within your local area, the telephone number is automatically stored without the area code in the call log.

1. Press **MENU/SELECT** when the handset is not in use.
2. Press **▼** or **▲** to select **>SETTINGS**, then press **MENU/SELECT**.
3. Press **▲** or **▼** to select **>HOME AREA CODE**, then press **MENU/SELECT**.
4. Use the dialing keys to enter the desired home area code.
 - Press **MUTE/DELETE** to delete a digit.
 - Press and hold **MUTE/DELETE** to delete the entire entry.
5. Press **MENU/SELECT** to save the selection. You hear a confirmation tone.

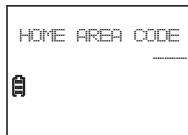
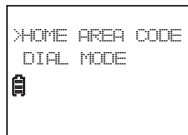

note

If, in the future, your telephone service provider requires you to dial the area code when making a local call, or, if you move to a location that requires it, delete the home area code you have already programmed, following the steps above. After you have deleted the home area code, **---** will appear in the display.

Dial mode

The default dial mode is tone dialing. If you have pulse (rotary) service, you need to change the dial mode to pulse dialing before using the telephone.

1. Press **MENU/SELECT** when the handset is not in use.
2. Press **▲** or **▼** to select **>SETTINGS**, then press **MENU/SELECT**.
3. Press **▲** or **▼** to select **>DIAL MODE**, then press **MENU/SELECT**.
4. Press **▲** or **▼** to choose **TONE** or **PULSE**.
5. Press **MENU/SELECT** to save your selection. You hear a confirmation tone.

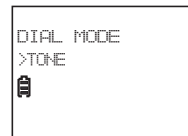
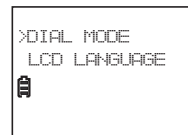

Telephone operation

Make a call

1. Press **TALK/FLASH**, then wait for a dial tone.

-OR-

Press **☎** to use the speakerphone, then wait for a dial tone.

2. Use the dialing keys to enter the telephone number.

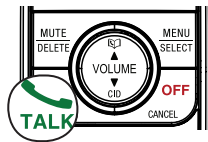

Redial a call

1. Use the dialing keys to enter the telephone number (up to 30 digits).
 - Press and hold **REDIAL/PAUSE** to insert a dialing pause (a **P** appears).
 - Press **MUTE/DELETE** or **OFF/CANCEL** to make corrections.
2. Press **TALK/FLASH** or **☎** to call.

Answer a call

Press **TALK/FLASH** or **☎** or any dialing key (**0-9**, **TONE** or **#**).

End a call

Press **OFF/CANCEL** or put the handset in the telephone base or charger.

note

The screen shows the elapsed time as you talk (in hours, minutes and seconds).

Speakerphone

During a call, press **☎** to switch between speakerphone and normal handset use. When the speakerphone is active, the handset shows **SPEAKER** and **☎**.

Volume

During a call, press **▼/VOLUME** or **▲/VOLUME** to adjust the listening volume. When the volume reaches the minimum or maximum setting, you hear two beeps.

note

The handset earpiece volume setting and speakerphone volume setting are independent.

Telephone operation

Mute

The mute function allows you to hear the other party but the other party cannot hear you.

1. During a call, press **MUTE/DELETE** on the handset. The handset displays **MUTED** for a few seconds and **MUTE** appears until the mute function is turned off.
2. Press **MUTE/DELETE** again to resume the conversation. The handset screen temporarily shows **MICROPHONE ON**.

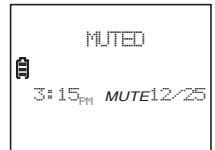
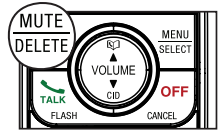

Call waiting

When you subscribe to call waiting service from your telephone service provider, you hear an alert tone if there is an incoming call while you are on another call.

- Press **TALK/FLASH** to put the current call on hold and take the new call.
- Press **TALK/FLASH** at any time to switch back and forth between calls.

Temporary ringer silencing

When the telephone is ringing, you can temporarily silence the ringer of the handset without disconnecting the call. The next call rings normally at the preset volume.

To silence the ringer:

When the telephone is ringing, press **OFF/CANCEL** or **MUTE/DELETE** on the handset, **RINGER MUTED** and  show on the screen.

Temporary tone dialing

If you have dial pulse (rotary) dialing service only, you can temporarily switch from dial pulse to touch-tone dialing during a call.

1. During a call, press **TONEX**.
2. Use the dialing keys to enter the number. The telephone sends touch-tone signals.
3. The telephone automatically returns to pulse dialing mode after you end the call.