



User's manual

TL86103

DECT 6.0 2-line

corded/cordless telephone/

answering system with

BLUETOOTH® wireless technology



Congratulations

on your purchase of this AT&T product. Before using this AT&T product, please read the **Important safety information** section on pages 148-149 of this manual. Please thoroughly read this user's manual for all the feature operations and troubleshooting information necessary to install and operate your new AT&T product. You can also visit our website at

www.telephones.att.com or call **1 (800) 222-3111**.

In Canada, dial **1 (866) 288-4268**.

This telephone system is compatible with certain AT&T DECT 6.0 cordless headsets. Visit **www.telephones.att.com/headsets** for a list of compatible cordless headsets.

Model number: TL86103

Type: DECT 6.0 2-line corded/cordless telephone/
answering system with BLUETOOTH® wireless technology

Serial number: _____

Purchase date: _____

Place of purchase: _____

Both the model and serial numbers of your AT&T product can be found on the bottom of the telephone base.

Save your sales receipt and original packaging in case it is necessary to return your telephone for warranty service.



Telephones identified with this logo have reduced noise and interference when used with most T-coil equipped hearing aids and cochlear implants. The TIA-1083 Compliant Logo is a trademark of the Telecommunications Industry Association. Used under license.



The ENERGY STAR® program (www.energystar.gov) recognizes and encourages the use of products that save energy and help protect our environment. We are proud to mark this product with the ENERGY STAR® label indicating it meets the latest energy efficiency guidelines.

The *Bluetooth*® word mark and logos are owned by Bluetooth SIG, Inc. and any use of such marks by Advanced American Telephones and its parent, VTech Holdings Limited, is under license. VTech Holdings Limited is a member of Bluetooth SIG, Inc. Other trademarks and trade names are those of their respective owners.

© 2013 Advanced American Telephones. All Rights Reserved. AT&T and the AT&T logo are trademarks of AT&T Intellectual Property licensed to Advanced American Telephones, San Antonio, TX 78219. Printed in China.

Parts checklist

Your telephone package contains the following items. Save your sales receipt and original packaging in the event warranty service is necessary.

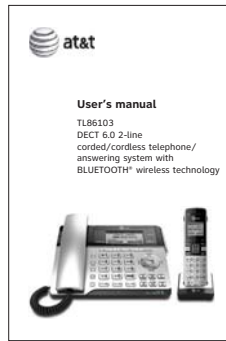

User's manual

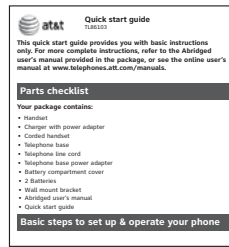

Quick start guide



Cordless handset



Telephone base



Corded handset with coiled handset cord attached



Charger for cordless handset with power adapter installed



Belt clip for cordless handset



Battery for cordless handset



Battery compartment cover



Power adapter for telephone base

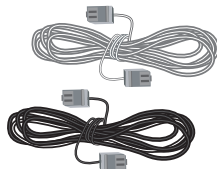

Telephone line cords (one black and one clear)



CD-ROM



USB cable

User's manual

TL86103
DECT 6.0 2-line
corded/cordless telephone/
answering system with
BLUETOOTH® wireless technology



Table of contents

Getting started

Installation.....	1
Quick reference guide - handset.....	2
Quick reference guide - telephone base.....	5
Telephone base and charger installation.....	9
Telephone base installation	9
Charger installation.....	10
Connect your telephone base to PC.....	11
Installation of AT&T Unified Call Manager on PC.....	11
Audio Settings.....	12
Battery installation and charging.....	13
Installation options.....	14
Tabletop to wall mount installation	14
Wall mount to tabletop installation	15
Belt clip & optional handset.....	16

Bluetooth

Introducing Bluetooth.....	17
Connect to Cell™ application	19
Glossary of terms.....	20
Bluetooth setup	21
Add a cell phone	21
Add a headset.....	23
Auto connection.....	25
Bluetooth connection from idle mode.....	25
Device list and connection	25
Review the device list.....	25

Connect/disconnect an active device.....	26
Remove a paired device.....	26
Replace an active device.....	27
Download directory.....	28
Interruption to directory download.....	30
View the directory download information	30
Change PIN.....	31
Cell ringer.....	31

Telephone settings

Handset and telephone base settings.....	32
Ringer volume	33
Ringer tone.....	34
LCD language.....	35
Set date/time.....	36
Caller ID announce.....	38
Set speed dial voicemail number.....	39
Voicemail (visual message waiting) number.....	41
Clear voicemail indication.....	41
Key tone.....	42
Use caller ID to automatically set date and time.....	42
Home area code.....	43
Cell area code.....	45
Dial mode.....	47
Line preference.....	47
QUIET mode	48
Web address	48

No line alert.....	49
Cell alert	49
Telephone operation	
Telephone operation.....	50
Make, answer or end a line 1 or line 2 call.....	50
Call waiting on line 1 or line 2...52	
Make, answer or end a cell call	53
Call waiting on the cell line.....	54
Answer an incoming cell call while on line 1 or line 2	55
Answer an incoming call on line 1 or line 2 while on a cell call.....	56
Make, answer or end a softphone call	57
Voice command.....	58
Conference calls.....	59
Conference calls on line 1 and line 2.....	59
Conference calls on line 1 or line 2 with cell calls.....	60
Options while on calls.....	62
Silencing the ringer	62
Page all devices	62
Speakerphone	63
Join a call in progress.....	63
Volume control	64
Mute	64
Temporary tone dialing	65
Hold.....	65
Equalizer.....	66
Chain dialing.....	67
Redial.....	69
Review the redial list.....	69
Dial a redial entry.....	69
Save a redial entry to the directory.....	71
Delete a redial entry from the directory.....	72
Intercom.....	73
Answer an incoming call during an intercom call.....	75
Call transfer using intercom	76
Push-to-talk (PTT)	78

Turn PTT on or off.....	78
PTT call to a single device.....	79
PTT call to multiple devices.....	81
Answer a PTT call.....	82
Change a one-to-one PTT call to an intercom call	83
Answer an incoming call during a PTT call.....	83
Make an outgoing call during PTT call	84
End or leave a PTT call.....	84

Directory

About the directory.....	85
Create directory entries.....	86
Create a new entry in the home directory.....	86
Dialing keys	88
Add a predialed telephone number to the directory.....	89
Review the directory.....	90
Review directory entries	90
Review the directory.....	91
Search the directory	92
3-character alphabetical search.....	92
Dial, edit or delete a directory entry.....	93
Dial a directory entry.....	93
Edit a directory entry.....	93
Edit the type of a directory entry.....	95
Delete a directory entry.....	95
Remove a downloaded directory.....	96

Caller ID

About caller ID	97
Information about caller ID with call waiting	97
Caller ID log.....	98
How the caller ID log works.....	98
Missed (new) call indicator	98
Memory match.....	98
Caller ID operation	99
Review the caller ID log.....	99
View dialing options.....	100
Dial a caller ID log entry	100
Save a caller ID log entry to the	

directory.....	101
Delete caller ID log entries.....	103
Reasons for missing caller ID information.....	104

Answering system

Answering system settings.....	105
Announcement.....	105
Answer on/off.....	108
Call screening.....	109
Number of rings.....	110
Remote access code.....	111
Message alert tone.....	112
Message recording time.....	113
About the answering system.....	114
Answering system and voicemail indicators.....	114
Using the answering system and voicemail together.....	114
Message capacity.....	115
Voice prompts.....	115
Temporarily turning off the message alert tone.....	115
Call screening.....	116
Call intercept.....	116
Message playback.....	117
Options during playback.....	118
Delete all old messages.....	120
Recording and playing memos.....	121
Record a memo.....	121
Playback a memo.....	121
Remote access.....	122
To remotely access the answering system.....	122

Appendix

Adding and registering cordless handsets/headsets/wireless speakers.....	124
Register a cordless handset to your telephone base.....	124
Deregister cordless handsets.....	125
Deregister all cordless handsets from the telephone base.....	125
Alert tones and lights.....	126
Handset screen icons.....	126
Telephone base screen icons.....	127
Handset alert tones.....	128

Telephone base alert tones.....	129
Lights.....	130
Display screen messages.....	131
Screen messages.....	131
Troubleshooting.....	135
Important safety information.....	148
Safety information.....	148
Especially about cordless telephones.....	149
Precautions for users of implanted cardiac pacemakers.....	149
ECO mode.....	149
Especially about telephone answering systems.....	149
Energy-saving charging mode.....	150
FCC Part 68 and ACTA.....	151
FCC Part 15.....	152
Limited warranty.....	153
Technical specifications.....	155
DECT 6.0 digital technology.....	155
Telephone operating range.....	155
Redefining long range coverage and clarity.....	155
HD audio.....	155
Simulated full duplex handset speakerphone.....	155

Index

Index.....	156
Remote access wallet card.....	158

Getting started
Installation

You must install and charge the battery before using the telephone.

STOP!

See page 13 for easy instructions.

Install the telephone base close to a telephone jack and a power outlet not controlled by a wall switch. The telephone base can be placed on a flat surface or vertically mounted on the wall (page 14-15). For optimum range and better reception, place the telephone base in a central and open location.

You may hear interference if your cellular phone is too close to the telephone base during a **CELLULAR** call. Make sure that your Bluetooth enabled cellular phone is within 15 feet of the telephone base in order to maintain a clear and consistent connection between your Bluetooth cell phone, telephone base and cell tower.

If you subscribe to high-speed Internet service (digital subscriber line - DSL) through your telephone line, you must install a DSL filter between the telephone line cord and the telephone wall jack (page 9-10). The filter prevents noise and caller ID problems caused by DSL interference. Please contact your DSL service provider for more information about DSL filters.

Your product may be shipped with a protective sticker covering the handset or telephone base display - remove it before use.

For customer service or product information, visit our website at **www.telephones.att.com** or call **1 (866) 288-4268**. In Canada, dial **1 (866) 288-4268**.

Avoid placing the telephone base too close to:

- Communication devices such as television sets, VCRs, or other cordless telephones.
- Excessive heat sources.
- Noise sources such as a window with traffic outside, motors, microwave ovens, refrigerators, or fluorescent lighting.
- Excessive dust sources such as a workshop or garage.
- Excessive moisture.
- Extremely low temperature.
- Mechanical vibration or shock such as on top of a washing machine or workbench.

Getting started
Quick reference guide - handset

CHARGE light

- On when the handset is charging in the charger.

Softkeys (2)

- Press to select the menu item displayed above the key (page 4)
- While in a menu, press to select an item or save an entry or setting.

A Cell/B Cell

- Press to make or answer a cell call (page 53).
- During a call, press to answer an incoming Cell A/B call when you hear a call waiting alert (page 54).

HOLD

- During a call, press to put the current call on hold (page 65).

LINE 1/FLASH/LINE 2/FLASH

- Press **LINE 1/FLASH** to make or answer a call on line 1 (page 50)
During a call, press to answer an incoming line 1 call when you hear a call waiting alert (page 46).
- Press **LINE 2/FLASH** to make or answer a call on line 2 (page 50)
During a call, press to answer an incoming line 2 call when you hear a call waiting alert (page 46).

1

- While reviewing a caller ID history entry, press repeatedly to add or remove **1** in front of the telephone number before dialing or saving it in the directory (page 100).
- Press and hold to set (page 39) or dial your voicemail number.

TONE*/a>A

- Press to switch to tone dialing temporarily during a call if you have pulse service (page 65).
- Press to switch between upper case and lower case while entering characters.

/SPEAKER

- Press to make a call on line 1 or line 2 using the handset speakerphone (page 50).
- Press to answer a call on line 1 or line 2 or a cell call using the handset speakerphone (pages 50, or 53).
- Press to turn on the handset speakerphone. Press again to resume normal handset use (page 58).

REDIAL/PAUSE

- Press to view the last 10 numbers dialed (page 61).
- While entering numbers, press and hold to insert a dialing pause (page 86).

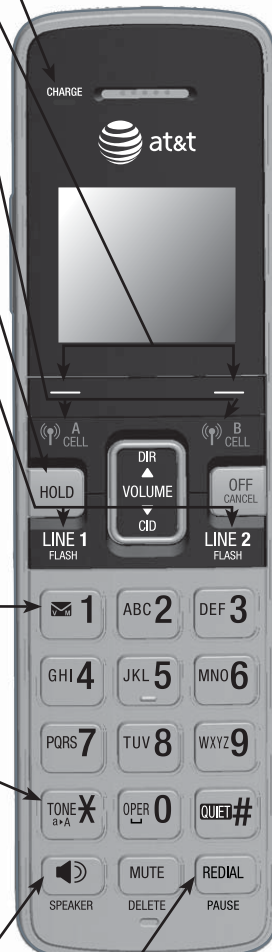

Getting started
Quick reference guide - handset



▲DIR/VOLUME

- Press to scroll up while in menus (page 90).
- Press to show directory entries when the telephone is not in use.
- While entering names or numbers in the directory, press to move the cursor to the right.
- Press to increase the listening volume when on a call (page 64), or to increase the message playback volume (page 118).

▼CID/VOLUME

- Press to scroll down while in menus. (page 90).
- Press to show the caller ID history when the telephone is not in use.
- While entering names or numbers in the directory, press to move the cursor to the left.
- Press to decrease the listening volume when on a call (page 64), or to decrease the message playback volume (page 118).

OFF/CANCEL

- While using menus, press to cancel an operation, back up to the previous menu, or exit the menu display, or press and hold this button to return to idle mode.
- During a call, press to hang up (pages 50).
- When the handset is ringing, press to mute the ringer temporarily (page 64).
- Press and hold while the telephone is not in use to erase the missed call indicator.

QUIET # (pound key)

- Press repeatedly to display other dialing options when reviewing a caller ID log entry (page 100).
- Press and hold to enter the **QUIET** mode setting screen, or to deactivate **QUIET** mode (page 48).
- Press to toggle the name order when saving a caller ID log entry into directory.

MUTE/DELETE

- During a call, press to mute the microphone (page 64).
- While the telephone base is ringing, press to silence the ringer temporarily (page 64).
- While predialing, press to delete digits.
- While reviewing the redial list, directory or caller ID history, press to delete an individual entry.
- While entering or editing a directory entry, press to erase a digit or character, or press and hold to erase all digits or characters.

Getting started
Quick reference guide - handset

Handset side view



PUSH TO TALK

- Press to initiate a one-to-one (page 79).
- Press and hold to broadcast to a group of system devices (page 73).

Main menu

The selected menu item is highlighted.



Feature menu

- Play messages (page 117)
- Directory (page 85)
- Caller ID log (page 97)
- Intercom (page 73)
- Ringers (page 33)
- Set date/time (page 36)
- Settings (page 32)
- Web address (page 48)
- Voice command (page 58)

Using menus:

- Press **MENU** to show the menu.
- Press **▼CID** or **▲DIR** to scroll through menu items.
- Press **SELECT** to confirm or save changes to a highlighted menu item.
- Press **OFF/CANCEL** to cancel an operation, back up to the previous menu, or exit the menu display.

Getting started
Quick reference guide - telephone base

HOLD

- During a call, press to put the current call on hold (page 65).

▼/VOLUME/▲

- Press to adjust the volume during message playback (page 64).
- Press to adjust the listening volume during a call (page 118).
- When the phone is not in use, press to adjust the telephone base ringer volume for all lines.

FLASH

- During a call, press to answer an incoming call when you receive a call waiting alert (page 46).

PTT

- Press to display the PTT menu to begin a PTT call (page 79).
- Press and hold to begin a one-to-group broadcast when the phone is not in use (page 73).

1

- While reviewing a caller ID history entry, press repeatedly to add or remove **1** in front of the telephone number before dialing or saving it in the directory (page 100).
- Press and hold to set or dial your voicemail number (page 39).



QUIET # (pound key)

- Press repeatedly to display other dialing options when reviewing a caller ID log entry.
- Press and hold to enter the **QUIET** mode setting screen, or to deactivate **QUIET** mode (page 48).

TONEX/a>A

- Press to switch to tone dialing temporarily during a call if you have pulse service.
- Switch between upper case and lower case while entering characters.

Getting started

Quick reference guide - telephone base

▼CID

- Press to scroll down while in a menu.
- Press to review the caller ID log when the telephone is not in use.
- While entering names or numbers, press to move the cursor to the left.

CANCEL

- While in a menu, press to exit without making changes or press and hold to return to idle mode.
- Press and hold while the telephone is not in use to erase the displayed messages (**XX Missed calls**, page 98).

Softkeys (2)

- Press to select the menu item displayed above the key.

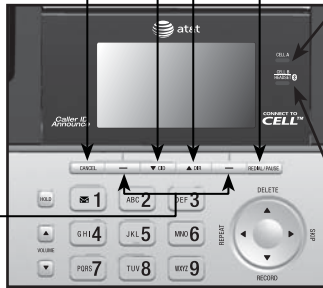

▲DIR

- Press to scroll up while in a menu.
- Press to show directory entries when the telephone is not in use.
- While entering names or numbers, press to move the cursor to the right.

REDIAL/PAUSE

- Press repeatedly to view the last 10 numbers dialed (page 61).
- While entering numbers, press and hold to insert a dialing pause.

CELL A light

- On when the telephone base is paired and connected with a Bluetooth cell phone on **Cell A** line (page 20).
- Flash alternately while pairing a Bluetooth device.

CELL B/HEADSET  light

- On when the telephone base is paired and connected with a Bluetooth device on **Cell B** line (page 20).
- Flash alternately while pairing a Bluetooth device.

SPEAKER 

- Press to make a call on line 1 or line 2 using the speakerphone (page 50).
- Press to answer a call on line 1 or line 2 or a cell call using the handset speakerphone.
- Press to switch between the speakerphone and corded handset.



1 LINE/2 LINE

- Press to make or answer a call on line 1 or line 2 (page 50).
- During a call, press to answer an incoming line 1 or line 2 call when you hear a call waiting alert. (page 46).

CELL A /CELL B 

- Press to make or answer a cell call (page 53).
- During a cell call, press to answer an incoming call when you hear a call waiting alert (page 54).
- Flashes quickly when there is an incoming cell call.
- Flashes slowly when a cell call is on hold.

Getting started
Quick reference guide - telephone base

▲/DELETE

- Press to delete the message currently playing (page 118).
- When the phone is not in use, press twice to delete all previously reviewed messages (page 120).
- While entering names or numbers, press to delete a digit or a character.
- While reviewing the redial list, directory or caller ID history, press to delete an individual entry.
- While predialing, press to delete a digit.

◀/REPEAT

- Press to repeat a message (page 118).
- Press twice to play the previous message.
- Press to show the remaining digits on the left.

⏻/LINE 1 ANS ON/OFF
⏻/LINE 2 ANS ON/OFF

- Press to turn the answering systems of line 1 or line 2 on or off (page 108).

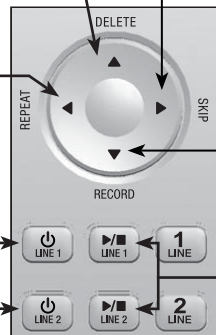

▶/SKIP

- During message playback, press to skip to the next message (page 118).
- Press to show the remaining digits on the left.

▼/RECORD

- Press to record an announcement or a memo (page 121).

▶/LINE 1 MAILBOX
▶/LINE 2 MAILBOX

- Press to play line 1 or line 2 messages (page 117).
- Press to stop playing line 1 or line 2 messages (page 118).

Small USB port

A standard size USB port in the telephone base is used for connection to PC.

USB ports

Two standard size USB ports in the telephone base are used for charging your cell phones.



Getting started

Quick reference guide - telephone base

Main menu

The selected menu item is highlighted.

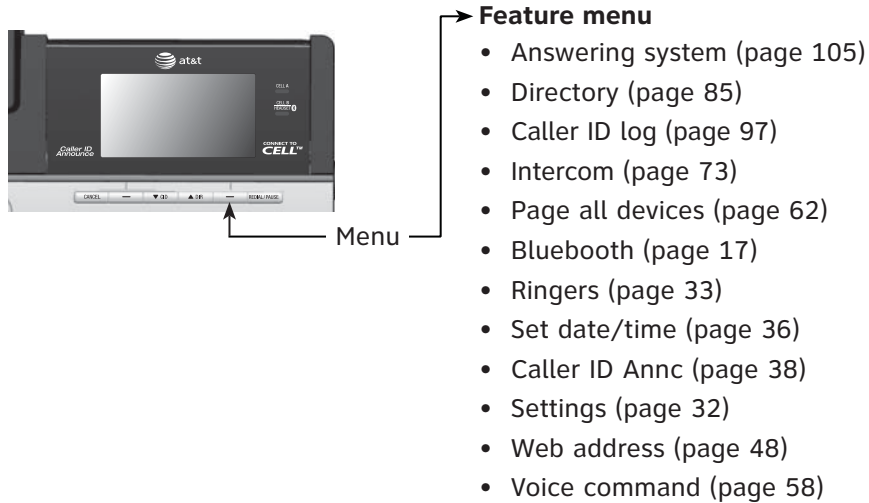

Using menus:

- Press **MENU** in idle mode to show the main menu.
- Press **▼CID**, **▲DIR**, **▼/RECORD** or **▲/DELETE** to scroll through menu items.
- Press **SELECT** to confirm or save changes to a highlighted menu item.
- Press **CANCEL** to cancel an operation, back up to the previous menu, or exit the menu display.

Getting started

Telephone base and charger installation

Install the telephone base and charger as shown below.

The telephone base is ready for tabletop use. If you want to change to wall mounting, see **Installation options** on page 14 for details.

Telephone base installation

1. Rotate the wall mount bracket down and push it into the telephone base until it clicks into place. Plug the end of the corded handset cord into the telephone jack at the back of the telephone base. Plug the small end of the telephone base power adapter into the power line jack at the back of the telephone base and route the cord through the slot.
2. Rotate the wall mount bracket up and push it into the telephone base until it clicks into place.

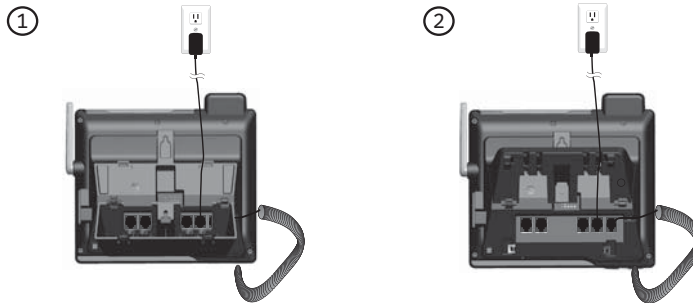

3. Plug the telephone line(s) according to the instructions below.

Option 1: If you have separate wall jacks for each line, plug the telephone lines as shown below.

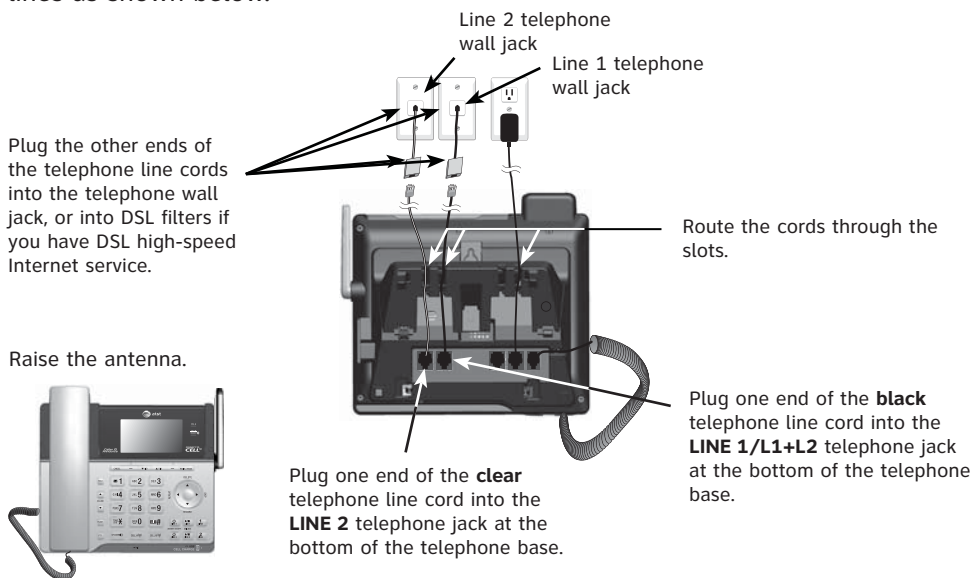

Getting started

Telephone base and charger installation

Option 2: If you have a 2-line wall jack, plug the 4-conductor telephone line as shown below.

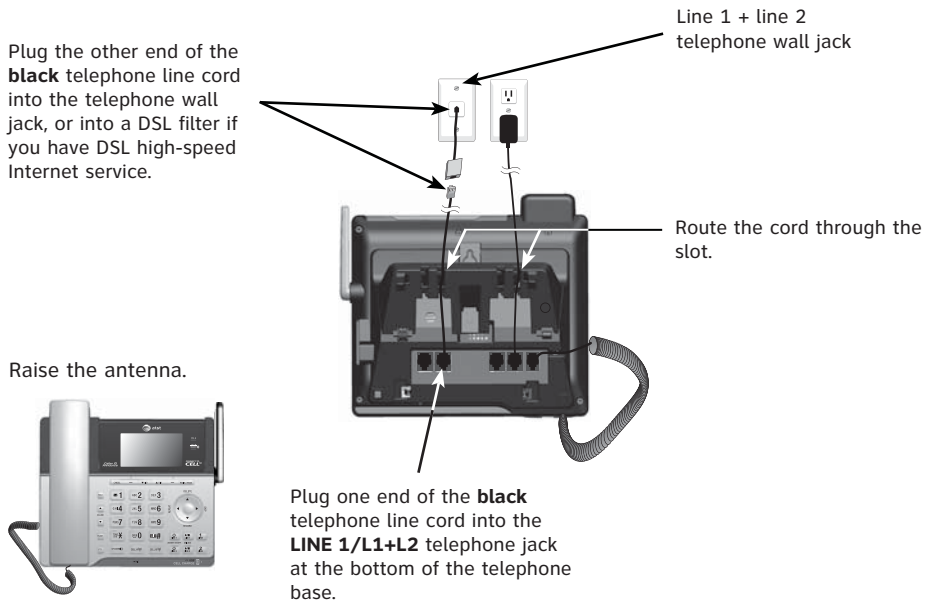

Charger installation

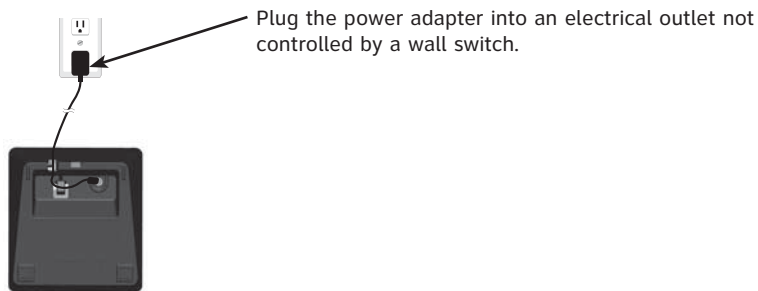

IMPORTANT INFORMATION:

- Use only the power adapter(s) provided with this product. To obtain a replacement, visit our website at **www.telephones.att.com** or call **1 (800) 222-3111**. In Canada, dial **1 (866) 288-4268**. For more detailed instructions, refer to the online Complete user's manual at **www.telephones.att.com/manuals**.
- The power adapters are intended to be correctly oriented in a vertical or floor mount position. The prongs are not designed to hold the plug in place if it is plugged into a ceiling, under-the-table or cabinet outlet.

Getting started

Connect your telephone base to PC

Your new AT&T **TL86103** allows you receive or make softphone calls by connecting the telephone base to your computer using the USB cable. You can make and answer Voice over IP (VoIP) calls through Skype™ or Microsoft Lync®, landline calls or cell calls using the **AT&T Unified Call Manager**. You can also use the voice command feature to make calls (see page 52) after you have installed the **AT&T Unified Call Manager**.

To connect the telephone base to your computer:

- Plug the USB cable into your computer as shown below. Wait for your computer to indicate that it has recognized the telephone base.

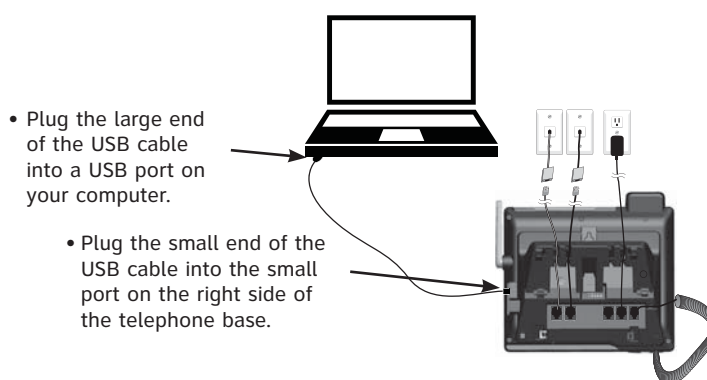

Installation of AT&T Unified Call Manager on PC

To install AT&T Unified Call Manager:

Put the CD-ROM that comes with the package into your computer. Open **My computer**, and then double click to open the disk drive. Double click the installation file to begin the InstallShield Wizard.

1. If any security warning window pops up, click the appropriate button to authorize the installation of the software. Click **Run**.
2. Choose your desired setup language, Click **Next>** to proceed to installation preparation. After that, a welcome screen appears.
3. Click **Next>**. Read the license agreement, and then accept the terms by pressing the upper checkbox. Press **Next>** to continue.
4. The default installation path is C:\Program.files\AT&T\AT&T Softphone Call Manager. Click the **Browse...** button to change the path if necessary. Click **Next>**.
5. Click **Install** to begin installation.
6. When the installation is done, press **Finish** to exit the installation program. If you want to launch the **AT&T Softphone Call Manager** after installation, tick the option checkbox before pressing **Finish**.

Skype™ is a trademark of Skype.

Microsoft Lync® is a registered trademark of Microsoft Corporation

Connecting your telephone base to PC

Audio Settings

After you have installed the **AT&T Unified Call Manager**, check to make sure the audio setting is properly configured in your Windows system. If you have installed Skype or Microsoft Lync and want to use them with your telephone base, make sure the audio settings are configured correctly in the programs as well.

a) Audio settings in Microsoft® Windows® system:

For Windows XP® users:

- i. Click **Start** menu and choose **Control Panel**.
- ii. Click **Sounds, Speech, and Audio Devices** and then click **Sounds and Audio Devices**.
- iii. Click the **Audio** tab.
- iv. Make sure **AT&T DECT 6.0 Telephone** is selected under the **Sound playback** and **Sound recording** settings.

For Windows 7 users:

- i. Click **Start** menu and choose **Control Panel**.
- ii. Click **Hardware and Sound** and then click **Manage audio devices** under the **Sound** menu.
- iii. Click the **Playback** tab and make sure **AT&T DECT 6.0 Telephone** is set as the default speaker.
- iv. Click the **Recording** tab and make sure **AT&T DECT 6.0 Telephone** is set as the default microphone.

b) Audio settings in Skype:

- i. Launch the Skype program.
- ii. Click on **Tools**, and then **Options**.
- iii. Click on **Audio settings**.
- iv. Make sure **AT&T DECT 6.0 Telephone** is selected under the speakers and microphone settings.

c) Audio settings in Microsoft Lync:

- i. Launch the Microsoft Lync program.
- ii. Click on **Options**, and then **Audio device**.
- iii. Make sure **AT&T DECT 6.0 Telephone** is selected under the Audio device setting.





IMPORTANT

Periodically check for software updates. Go to the **ABOUT** tab under the **Settings** panel in the **AT&T Unified Call Manager**, and then click **CHECK UPDATED**. For more details, refer to the **Software updates** section in the **Installation and Operation Guide**, available in the **CD-ROM** which comes with the package.

Getting started

Battery installation and charging

Install the battery as shown below. Once you have installed the battery, the screen indicates the battery status (see table below). For best performance, keep the cordless handset in charger when not in use. The battery is fully charged after 11 hours of continuous charging. See the table in the **Technical specifications** section on page 155 for battery operating times.

Battery indicators	Battery status	Action
The screen is blank or shows Place in charger and  flashes.	The battery has no or very little charge. The handset cannot be used.	Charge without interruption (at least 30 minutes).
The screen shows Low battery and  flashes.	Battery has enough charge to be used for a short time.	Charge without interruption (at least 30 minutes).
The screen shows HANDBSET X.	Battery is charged.	To keep the battery charged, place it in charger when not in use.



Step 1

Plug the battery connector securely into the socket inside the handset battery compartment. Insert the supplied battery with the label **THIS SIDE UP** facing up as indicated.



Step 2

Align the cover flat against the battery compartment, and then slide it upwards until it clicks into place.

CHARGE light



Step 3

Charge the cordless handset by placing it face forward in the charger. The **CHARGE** light on the top of the handset is on during charging.

IMPORTANT INFORMATION:

- Use only the supplied rechargeable battery or replacement battery (model BT184342/ BT284342). To order, visit our website at www.telephones.att.com or call **1 (800) 222-3111**. In Canada, dial **1 (866) 288-4268**.
- If you do not use the handset for a long time, disconnect and remove the battery to prevent possible leakage.

Getting started

Installation options

Your telephone base is ready for tabletop use. If you want to mount your telephone on a wall, follow the steps below to connect the telephone base with a standard dual-stud telephone wall mounting plate. You may need a professional to install the wall mounting plate.

Tabletop to wall mount installation

1. Unplug the power adapter from the power outlet. Unplug the telephone line cord from the wall jack (or DSL filter).
2. Put the handset aside. Hold down the switch hook on the telephone base, and then slide the handset tab upwards to remove it from the slot. Rotate the handset tab by 180 degrees. Then replace the handset tab into the slot until it locks into position.
3. Press down on the tabs of the wall mount bracket as indicated to release it from tabletop orientation.
4. Rotate the wall mount bracket down and push it into the telephone base until it clicks into place.
5. Plug the telephone line cord (or DSL filter) into the wall jack. Plug the power adapter into a power outlet not controlled by a wall switch. Align the slots on the back of the telephone base with the studs of the wall mounting plate.
6. Slide the telephone base down until it locks securely. Bundle the telephone line cord and power adapter cord neatly with twist ties.

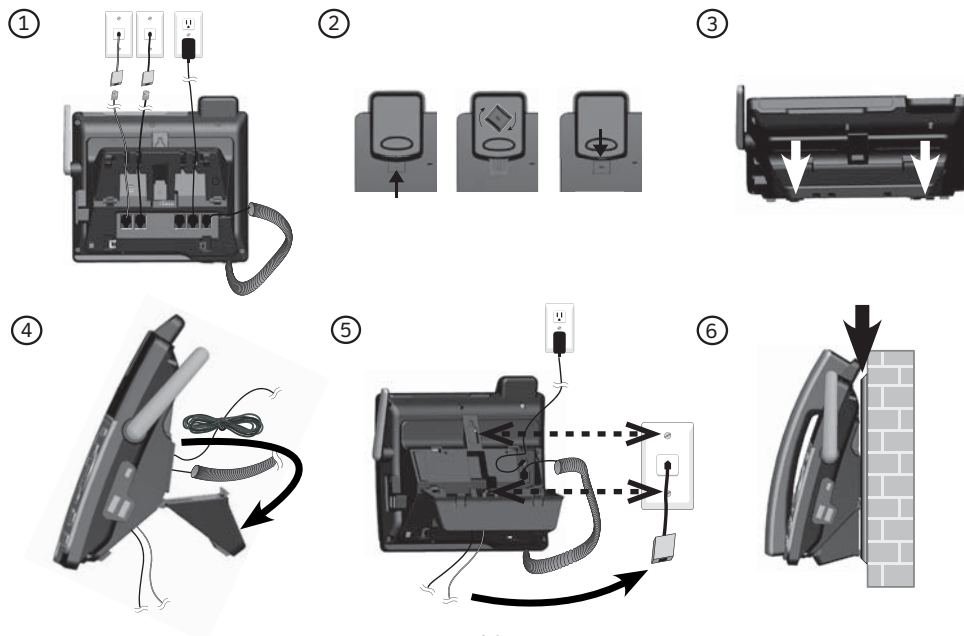

Installation options

Wall mount to tabletop installation

To change the telephone base from the wall mount position to tabletop position, follow the steps below.

1. Unplug the power adapter from the power outlet. Unplug the telephone line cord from the wall jack (or DSL filter). If the telephone line cord and power adapter cord are bundled, untie them first. Push the telephone base up to remove it from wall.
2. Put the handset aside. Hold down the switch hook on the telephone base, and then slide the handset tab upwards to remove it from the slot. Rotate the handset tab by 180 degrees. Then replace the handset tab into the slot until it locks into position.
3. Gently pull upward to release the wall mount bracket. Rotate the wall mount bracket up to tabletop position and push it into the telephone base until it clicks into place.
4. Plug the telephone line cord (or DSL filter) into the wall jack. Plug the power adapter into a power outlet not controlled by a wall switch. Bundle the telephone line cord and power adapter cord neatly with twist ties if necessary.

①



②



③



④

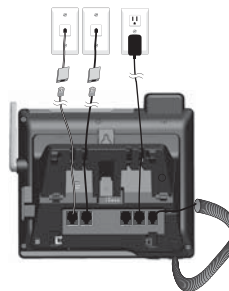

Getting started

Belt clip & optional headset

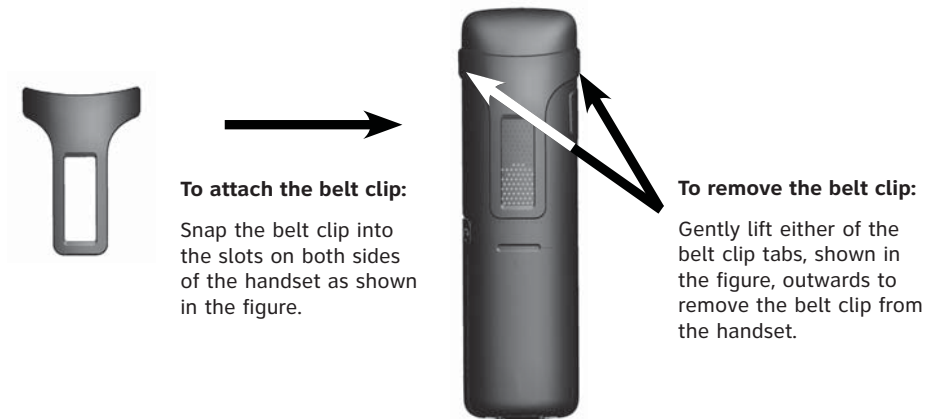

For handsfree telephone conversations, you can use any industry standard 2.5 mm headset (purchased separately). For best results, use an AT&T 2.5 mm headset. To purchase a headset, visit our website www.telephones.att.com or call **1 (800) 222-3111**. In Canada, dial **1 (866) 288-4268**.

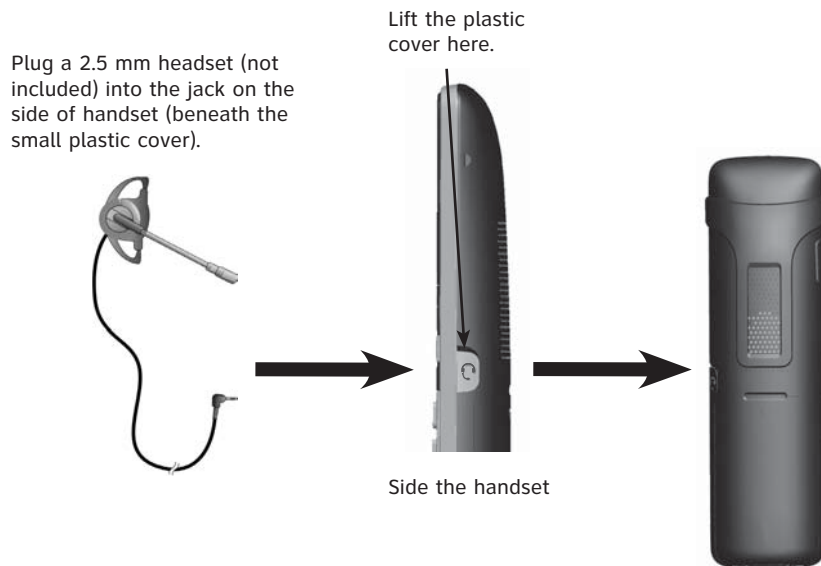

Bluetooth

Introducing Bluetooth

Your new AT&T **TL86103** telephone system with Bluetooth wireless technology has the following features:

- Pair up to 4 Bluetooth enabled devices (cell phones or headsets) with the telephone base.
- Connect a maximum of 2 cell phones to make and receive cell calls. Both cell phones can be active on a call at a time.
- Connect a Bluetooth enabled headset for making and receiving calls on line 1 or line 2.
- Conference any combination of cell and line 1 or line 2 calls.
- Make and receive calls using your cell phone service with your telephone base or system handsets.
- Download phonebook entries from your cell phone.
- Ringtone share feature allows you to set your telephone to play your iPhone® (iOS 4.1 or later) ringtone.

IMPORTANT INFORMATION

- After plugging in the telephone base, wait at least 20 seconds before connecting a Bluetooth device. The screen shows **Bluetooth system busy** if you try to connect too soon.
- Refer to the user's manual of your Bluetooth enabled cell phone or headset for more information about how that device uses Bluetooth connectivity.
- Bluetooth wireless technology operates within a short range (up to 30 feet) from the telephone base. Keep connected cell phones and headsets within this range.
- If your cell phone has poor reception in your home, the **TL86103** cannot improve the reception. However, if there is a location in your house with better reception, you can leave your cell phone at that location while you use the **TL86103** cell line. For optimal performance, the cell phone must be within 15 feet of the telephone base.

iPhone® is a registered trademark of Apple, Inc.

Bluetooth Introducing Bluetooth

- If you experience poor sound quality, it may be caused by the distance between your cell phone and the telephone base. To improve the performance, place your cell phone closer to the telephone base (within 15 feet) and make sure that there are no physical obstacles such as large furniture or thick wall in between.

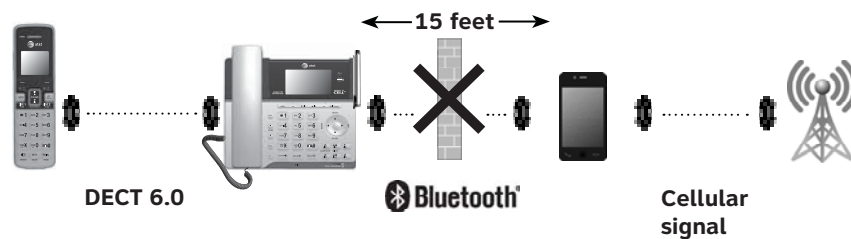

- Charge your cell phone while it is connected to the telephone base. Your cell phone's battery discharges faster while it is connected to the telephone base via Bluetooth wireless technology.
- Monitor your cell phone's usage because minutes may be deducted from your cellular plan for the duration of all cell calls, depending on the terms of your plan.

Refer to the **Bluetooth setup** section (pages 21-31) to learn how to set up your Bluetooth device. Refer to the **Telephone operation** section (pages page 50-58) on how to operate your Bluetooth devices with your new AT&T **TL86103** telephone system with Bluetooth wireless technology. Refer to the **Troubleshooting** section (pages page 135-147) if you experience difficulty when using the telephone system.

The *Bluetooth*[®] word mark and logos are owned by Bluetooth SIG, Inc. and any use of such marks by Advanced American Telephones and its parent, VTech Holdings Limited, is under license. VTech Holdings Limited is a member of Bluetooth SIG, Inc. Other trademarks and trade names are those of their respective owners.

Bluetooth

Introducing Bluetooth

Connect to Cell™ application

If you are using Bluetooth-enabled cell phones with Android® OS 2.3 or above, you can further extend the flexibility of your **TL86103** with use of the free **Connect to Cell** application.

Connect to Cell comprises **Caller ID manager** and **Alerts manager** that help integrate your cell phone with the AT&T telephone system.

Caller ID manager (Caller ID share) allows you:

- To view your AT&T phone's caller ID log on your Android cell phone;
- To use your Android cell phone to call back or send messages to individuals who have called to line 1 or line 2 on the AT&T telephone;
- To store callers' names and numbers to your Android phone's directory for future use.

Alerts manager (Mobile notification) allows you to extend your Android phone's alerts to your AT&T telephone system. Your AT&T telephone will notify you whenever you receive certain text messages, e-mails or social media updates on your Android phone, so you will always be kept up to date.

To use **Caller ID manager** and **Alerts manager**, you must first download **Connect to Cell** to your Android cell phone using the **Google Play® Store** app. Scan the QR code on the right to download the application.



Connect to cell™ is a trademark of Advanced American Telephones.
Android® and Google Play® are registered trademarks of Google Inc.

Bluetooth

Glossary of terms

Below are some terms used in this user's manual to help you become familiar with using your Bluetooth devices and your new AT&T telephone system.

Active devices the **Device list** has two active slots for two cell phones, or one cell phone and one headset. When a device in the list is active it will have a A: or B: in front of the device name. In order to use a Bluetooth device on a call, it must be in an active slot and be connected.

Bluetooth cell phone - refers to a mobile Bluetooth enabled cellular telephone.

CELL line - the telephone line associated with your cell phone service. On your **TL86103**, press **☎ A Cell** or **☎ B Cell** on a handset, or **Cell A** or **Cell B** on the telephone base to use the cell line.

Connected - when you pair a Bluetooth device to the **TL86103** it is placed in an active slot and automatically connected. When a device is connected, a **A** and/or **B** will display on screens of the handset and the telephone base, and the **CELL A** and/or **CELL B/HEADSET** light on the telephone base will be on. If a device loses its connection to the telephone base, it must be reconnected before you can use the device with the telephone system.

Device list - The list of devices connected to the telephone.

Disconnected - when a device is disconnected, **A** and/or **B** displays on the screens of handsets and the telephone base, and the **CELL A** and/or **CELL B/HEADSET** light on the telephone base is off.

Discoverable mode - before a Bluetooth enabled device can be paired, it must be set to this mode. When pairing your cell phone, the telephone base is set to this mode. Depending on the cell phone manufacturer, this mode is sometimes referred to as **Find Me** or **Visibility**.

LINE 1 and **LINE 2** - your conventional telephone land lines. On your **TL86103**, press **LINE 1/FLASH** or **LINE 2/FLASH** on a handset or **1 LINE** or **2 LINE** on the base to use the corresponding line.

Paired devices - The Bluetooth enabled devices (cell phones or headsets) that have shared registration information with the telephone base. A total of four Bluetooth enabled devices can be paired to the telephone base. However, only two paired devices can communicate with the base at a time.

Pairing - sometimes referred to as **bonding**. The process of sharing registration information between two Bluetooth enabled devices. Your Bluetooth enabled cell phone or headset must first be paired to the telephone base in order to use it with this telephone system.

PIN - by default, the PIN is **0000** for the telephone base and for most Bluetooth devices. PIN information may be exchanged between Bluetooth devices before they can be used. This is also known as a **Passkey** or **Passcode**.

Bluetooth

Bluetooth setup

To use a Bluetooth enabled cellular phone or headset with your telephone, you must first pair and connect your Bluetooth cellular phone or headset with the telephone base. The **TL86103** can then be used to make or answer calls on the cell phone line.

Bluetooth wireless technology operates within a short range (up to 30 feet). When you pair a Bluetooth cell phone or Bluetooth headset to the telephone base, keep the device within 15 feet of the telephone base for optimal performance.

Add a cell phone

Before you begin, make sure that you have cellular coverage and your Bluetooth enabled cell phone is not connected to any other Bluetooth device. Refer to your cell phone user's manual to learn how to search for or add new Bluetooth devices.

To pair and connect a cell phone:

Using the telephone base:

1. Press **MENU** on the telephone base in idle mode to enter the main menu.
2. Press **▼CID**, **▲DIR**, **▼/RECORD** or **▲/DELETE** to highlight **Bluetooth**, and then press **SELECT**.
3. Press **SELECT** to choose **Add device**.
4. Press **SELECT** to choose **Add cellular**. The screen displays **Please wait...**, followed by **1. If cell is connected to BT device, please disconnect it**.
 - If there are already 4 paired devices on the device list, the 4th device on the device list will be automatically removed, regardless of whether the new device pairing is successful or not.
 - If there are already 2 active devices on the device list with prefix **A:** or **B:**, the telephone base shows **Cell phone A is deactivated for adding a new device**.
5. Press **NEXT**. The screen displays **2. Place cell phone next to base**.
 - All devices that are connected to the telephone base are disconnected until the pairing process is completed.
6. Press **NEXT** to turn on the telephone base discoverable mode. The screen displays **Set cell to search base: AT&T DECT 6.0 PIN: 0000**. Promptly turn on the Bluetooth feature of your cell phone and search for or add new devices.



```
Caller ID log
Intercom
Page all devices
Bluetooth
BACK SELECT
```



```
BLUETOOTH
Add device
Device list
Download dir
BACK SELECT
```



```
ADD DEVICE
Add cellular
Add headset
BACK SELECT
```

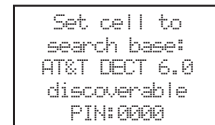

```
Set cell to
search base:
AT&T DECT 6.0
discoverable
PIN:0000
```

Bluetooth

Bluetooth setup

7. Once your cell phone finds your AT&T phone (**AT&T DECT 6.0**), press the appropriate key on your cell phone to continue the pairing process.
 - Your cell phone may require a passcode. In this case, the telephone base displays **Check cellular. ENTER PASS CODE**. Enter the cell phone passcode (typically **0000**) into the telephone base and press **SET**.
 - Enter the PIN of the telephone base (the default PIN is **0000**) into your cell phone to continue the pairing process if required. The telephone base displays **Adding Cell Phone A**.
8. When a device is successfully connected, the telephone base displays **Cell Phone A is added and connected to base**. You hear a confirmation tone. The corresponding status icon (**A** or **B**) displays. The corresponding device light on the telephone base (**CELL A** and/or **CELL B/HEADSET**) turns on.

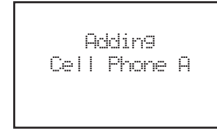

Adding
Cell Phone A

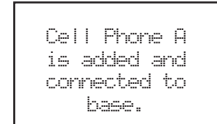

Cell Phone A
is added and
connected to
base.

If you have trouble pairing your cell phone, it may not be compatible with your TL86103. Check the Bluetooth compatibility list at www.telephones.att.com.



NOTES:

- The pairing process may take up to one minute. If the pairing process fails, turn off the bluetooth feature on your cell phone and on the **TL86103** by pressing **A** or **B**. Then repeat the steps in the user's manual to pair and connect again. In some cases, it may take you a few attempts to complete the pair process.
- The steps for the pairing process may vary for different cell phones. If this happens, follow the prompts on your cell phone and your **TL86103** to complete the pairing process.
- Refer to the user's manual of your cell phone on how to search for or add a new Bluetooth device.

Bluetooth Bluetooth setup

Add a headset

Before you begin, make sure that your Bluetooth enabled headset is not connected to any other Bluetooth device. Refer to your headset user's manual to learn how to search for or add new Bluetooth devices.

To pair and connect a headset:

Using the telephone base:

1. Press **MENU** on the telephone base in idle mode to enter the main menu.
2. Press **▼CID, ▲DIR, ▼/RECORD** or **▲/DELETE** to highlight **Bluetooth**, and then press **SELECT**.
3. Press **SELECT** to choose **Add device**.
4. Press **▼CID, ▲DIR, ▼/RECORD** or **▲/DELETE** to highlight **Add headset**, and then press **SELECT**. The screen displays **If headset is connected to cell, please disconnect it**.
 - If there are already 4 paired devices on the device list, the 4th device on the device list will be automatically removed, regardless of whether the new device pairing is successful or not.
 - If there is another headset already active, the screen will show **Only BT devices in slot 1 or 2 can be ready for connection** and prompts you to replace an existing paired device.
 - If there are already 2 active devices on the device list with prefix **A:** or **B:**, the screen shows **Only 2 devices can be ready for connection**. The screen prompts you too deactivate an active device.
5. Press **NEXT**. The screen displays **Pls set headset to discoverable mode**. Set your headset to discoverable mode (refer to the user's manual of your headset), and then press **NEXT**.
 - All devices that are connected tot the telephone base are temporarily disconnected.
6. The screen displays **Searching for Bluetooth headsets...**
7. When the screen displays the found devices, press **▼CID, ▲DIR, ▼/RECORD** or **▲/DELETE** to highlight your headset if necessary then press **SELECT**.
 - Enter the PIN of your headset if required. The PIN for most Bluetooth devices is **0000** (refer to the user's manual of your headset), and then press **NEXT**.

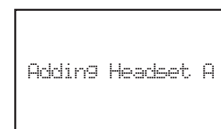
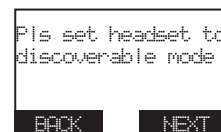
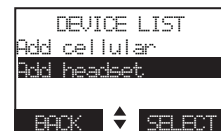

Bluetooth

Bluetooth setup

8. The screen displays **Adding Headset A** when the base is connecting to your headset.
9. When a device is successfully connected, the telephone base displays **Headset A is added and connected to base** and the corresponding status icon (📶 B) displays. You hear a confirmation tone. **CELL B/HEADSET** 📶 light on the telephone base turns on.

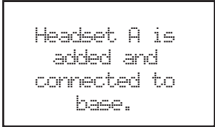

Headset A is
added and
connected to
base.

If you have trouble pairing your cell phone or headset, it may not be compatible with your TL86103. Check the Bluetooth compatibility list at www.telephones.att.com/bluetooth.



NOTES:

- The pairing process may take up to one minute. If the pairing process fails, try again.
- When a connected headset is charging, it may disconnect from the telephone base and the corresponding light on the telephone base (**CELL B/HEADSET** 📶) turns off. For some headset models, you may need to turn on the headset and reconnect it to the telephone base again.

Bluetooth

Bluetooth setup

Auto connection

When an active device moves within Bluetooth range of the telephone base, or is turned on within range, the telephone base tries to connect to the device. When the device moves out of range, it is disconnected. Your device might make a connect or disconnect sound.

A connected device could also be disconnected by:

- Turning off the Bluetooth device.
- Turning off the Bluetooth feature of the device.
- Disconnecting through the telephone base **Device list**. If you disconnect through the **Device list**, the telephone base will not attempt to reconnect until your device is moved out of range and then moves back in range again.

Bluetooth connection from idle mode

When you have active devices that are not connected, **CONNECT** appears on the telephone base in idle mode. Press **CONNECT** on the telephone base to start connecting an active device. When there are two active devices, the screen will prompt you to choose one before connection

Device list and connection

Up to 4 devices can be paired to the telephone base. All paired devices are shown on the device list. To use a paired device, it must be in an active slot (**A:** or **B:**) on the device list and connected. Two Bluetooth cell phones can be on a call at a time. While you are on a cell line call, you can also use a Bluetooth headset to make or answer a call on line 1 or line 2.

Once you have paired a device with the telephone base, you do not need to repeat the pairing procedure again unless you delete the device from the device list.

 **NOTE:** When connecting a Bluetooth device to the device list, all connected devices will be temporarily disconnected until the procedure is complete. It may take up to 2 minutes to reconnect.

Review the device list

1. Press **MENU** on the telephone base in idle mode.
2. Press **▼CID, ▲DIR, ▼/RECORD** or **▲/DELETE** to highlight **Bluetooth**, and then press **SELECT**.
3. Press **▼CID, ▲DIR, ▼/RECORD** or **▲/DELETE** to highlight **Device list**, and then press **SELECT**.

Bluetooth Bluetooth setup

Connect/disconnect an active device

While in the device list menu, you may connect or disconnect your active device.

1. Press **MENU** on the telephone base in idle mode to enter the main menu.
2. Press **▼CID, ▲DIR, ▼/RECORD** or **▲/DELETE** to highlight **Bluetooth**, and then press **SELECT**.
3. Press **▼CID, ▲DIR, ▼/RECORD** or **▲/DELETE** to highlight **Device list**, and then press **SELECT**.
4. Press **▼CID, ▲DIR, ▼/RECORD** or **▲/DELETE** to highlight a device, and then press **OPTION**.
5. Press **▼CID, ▲DIR, ▼/RECORD** or **▲/DELETE** to highlight **Connect/Disconnect** (whichever is applicable), and then press **SELECT**. The telephone base displays **Device connected/Device disconnected**. You hear a confirmation tone.

i **NOTE:** When your active device is connected, you are prompted to select **Disconnect**. When your active device is disconnected, you are prompted to select **Connect**.

Remove a paired device

When you already have a maximum of 4 paired devices on the device list and you want to add another device, you must first delete a device from the device list.

To remove a paired device:

1. Press **MENU** on the telephone base in idle mode to enter the main menu.
2. Press **▼CID, ▲DIR, ▼/RECORD** or **▲/DELETE** to highlight **Bluetooth**, and then press **SELECT**.
3. Press **▼CID, ▲DIR, ▼/RECORD** or **▲/DELETE** to highlight **Device list**, and then press **SELECT**.
4. Press **▼CID, ▲DIR, ▼/RECORD** or **▲/DELETE** to highlight the desired device, and then press **OPTION**.
5. Press **▼CID, ▲DIR, ▼/RECORD** or **▲/DELETE** to highlight **Remove**, and then press **SELECT**.
6. The handset displays **Remove Cell Phone A?** Press **YES** to confirm. The telephone base displays **Device removed from device list** and you hear a confirmation tone.

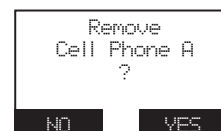
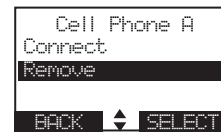
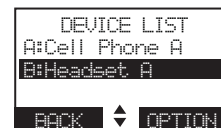

Bluetooth Bluetooth setup

Replace an active device

If you already have 2 active devices on the device list and you want to activate a different device, you must deactivate one of the 2 active devices.

To replace an active device:

1. Press **MENU** on the telephone base in idle mode.
2. Press **▼CID, ▲DIR, ▼/RECORD** or **▲/DELETE** to highlight **Bluetooth**, and then press **SELECT**.
3. Press **▼CID, ▲DIR, ▼/RECORD** or **▲/DELETE** to highlight **Device list**, and then press **SELECT**.
4. Press **▼CID, ▲DIR, ▼/RECORD** or **▲/DELETE** to highlight the device you want to activate without a prefix **A:** or **B:** then press **OPTION**.
5. Press **▼CID, ▲DIR, ▼/RECORD** or **▲/DELETE** to highlight **Connect**, and then press **SELECT**. The handset displays **Only BT devices in slot 1 or 2 can be ready for connection** and then a list of devices for deactivation.
6. Press **▼CID, ▲DIR, ▼/RECORD** or **▲/DELETE** to highlight the device to be deactivated, and then press **NEXT**. The screen displays **Cell Phone A is deactivated** and you hear a confirmation tone. The screen then displays **Connecting Cell Phone B to the base...**
7. Depending on your cell phone settings, you may need to press a key on your cell phone to confirm the connection. When the new device is successfully activated and connected, the handset displays **Device connected**. You hear a confirmation tone.

i **NOTE:** When adding removing, or replacing a Bluetooth device on the active devices list, all connected devices are temporarily disconnected until the procedure is complete. It may take up to 2 minutes to reconnect.

```
BLUETOOTH
Add device
Device list
Download dir
BACK  ▲▼  SELECT
```

```
DEVICE LIST
A:Cell Phone A
B:Headset A
Cell Phone B
BACK  ▲▼  OPTION
```

```
Only BT devices
in slot 1 or 2
can be ready
for connection
```

```
DEACTIVATE
A:Cell Phone A
B:Headset A
BACK  ▲▼  NEXT
```

```
Connecting
Cell Phone B
to the base...
```

```
DEVICE LIST
A:Cell Phone B
B:Headset A
Cell Phone A
BACK  ▲▼  OPTION
```

Bluetooth
Bluetooth setup

Download directory

You can download up to 4 cell phone directories (phonebooks) to your **TL86103** telephone system via Bluetooth wireless technology. Each downloaded directory can store up to 1,500 entries with up to 30 digits for each phone number and 15 characters for each name.

Before downloading a directory, make sure the cell phone is paired, active, and connected to your **TL86103** telephone system.

Place your cell phone next to the telephone base when you download a cell phone directory to your **TL86103** telephone system.

To download a cell phone directory:

Using the telephone base:

1. Press **MENU** on the telephone base in idle mode.
2. Press **▼CID, ▲DIR, ▼/RECORD** or **▲/DELETE** to highlight **Bluetooth**, and then press **SELECT**.
3. Press **▼CID, ▲DIR, ▼/RECORD** or **▲/DELETE** to highlight **Download dir**, and then press **SELECT**.
 - If there is no cell phone paired to the system, the telephone base displays **Device list is empty**. Press **OK** to return to the Bluetooth menu.
 - If there are two active devices on the device list, press **▼CID, ▲DIR, ▼RECORD** or **▲DELETE** to highlight the desired device, and then press **SELECT**.
 - If the selected device is active but disconnected, the telephone base displays **Cellular phone not connected**. Press **CONNECT**.
4. Press **▼CID, ▲DIR, ▼RECORD** or **▲DELETE** to highlight one of the following options:
 - **Phone memory** - download all contacts stored in your phone memory.
 - **SIM card only** - download all contacts stored in your SIM card.
 - **Phone and SIM** - download all contacts stored in both your phone memory and SIM card.Press **SELECT** to continue. During the download, the telephone displays **CL) Downloading**. All other idle system handsets display **CL) Downloading...**
 - Your cell phone may require you to press a key to confirm the directory download.
 - Your cell phone may require a passcode. In this case

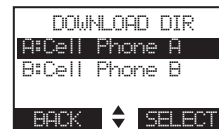

Bluetooth

Bluetooth setup

- If the selected device's directory has already been downloaded to **TL86103** before, the handset displays the date of the last download from your cell phone. The directory stored on the **TL86103** for that cell phone will be erased and replaced with the current cell phone directory. If you have edited the downloaded entries, those changes will be lost. Press **NEXT** to start the download.
 - If you already have 4 downloaded directories, the telephone base displays **Memory is full. Replace existing directory?** Press **YES** if replace an existing directory. Highlight the cell phone directory replaced and press **SELECT**. **The screen displays Replace Cell Phone A directory?** Press **YES** to confirm.
5. When the downloading process is complete, the handset displays **Download ended XXXX entries saved**. You hear a confirmation tone. Press **OK** to return to the **Bluetooth** menu.



NOTES:

- Certain cell phones do not support SIM card download. If this is the case, transfer the contacts from your SIM card to your cell phone memory first, and then download from your cell phone memory. For more information on how to transfer contacts from your SIM card to your cell phone memory, see the user's manual of your cell phone.
- If **Phone memory** is chosen but with no entries saved, the telephone base displays **No entries found. Download from SIM only?** Press **YES** to confirm. If **SIM card only** is chosen but with no entries saved, the handset displays **No entries found. Download from Phone only?** Press **YES** to confirm. If **Phone and SIM** are chosen but with no entries saved in either or both directories, the telephone base displays **No entries found. Download from Phone only?** Press **YES** to confirm.
- When downloading the directory from your Bluetooth enabled cell phone, some data may not transfer. For example, if you have home, mobile and work numbers for a particular contact, the three categories may not transfer to your **TL86103**.
- For certain cell phones, you may need to press a key to confirm the directory download.

Bluetooth Bluetooth setup

Interruption to directory download

If you are downloading a directory from a cell phone and the phone receives a call, the download process stops and the telephone base displays **Download failed** and all the handsets display **CL) Download fail**. When you try to view the downloaded directory, the telephone base and handsets display **Last Download failed: MM/DD/YY**. You need to download the directory again (see page 28).

When you are downloading a directory from a cell phone and you wish to stop the download process, you may press **STOP**. The telephone base displays **Download directory cancelled**. The telephone base displays **CL) Download fail** when it returns to idle mode.

i **NOTE:** During the download process, do not attempt to make changes to your cell phone directory.

View the directory download information

1. Press **MENU** on the telephone base in idle mode to enter the main menu.
 2. Press **▼CID, ▲DIR, ▼/RECORD** or **▲/DELETE** to highlight **Directory**, and then press **SELECT**.
 3. Press **▼CID, ▲DIR, ▼/RECORD** or **▲/DELETE** to choose the desired downloaded directory, and then press **OPTION**.
 4. Press **▼CID, ▲DIR, ▼/RECORD** or **▲/DELETE** to highlight **Last update**, and then press **SELECT**.
 - The telephone base displays **Cell phone A Last Update: MM/DD/YY Total #XXXX**.
- OR-**
- The telephone base displays **Cell phone A Last Download failed: MM/DD/YY** if there was an interruption during that directory download.
5. Press **OK** to exit.



```
Answering sys
Directory
Caller ID log
Intercom
BACK  ▲  SELECT
```



```
CELL PHONE A
Cell area code
Last update
Remove dir
BACK  ▲  SELECT
```



```
CELL PHONE A
Last update
29/07/13
Total #0159
OK
```

i **NOTE:** If a handset tries to access the directory while a Bluetooth directory download is in progress, the screen shows **Not available at this time**.

Bluetooth Bluetooth setup

Change PIN

You may be required to enter a PIN when establishing a Bluetooth connection. The default PIN of your telephone base is **0000**.

To change the PIN:

1. Press **MENU** on the telephone base in idle mode to enter the main menu.
2. Press **▼CID**, **▲DIR**, **▼/RECORD** or **▲/DELETE** to highlight **Bluetooth**, and then press **SELECT**.
3. Press **▼CID**, **▲DIR**, **▼/RECORD** or **▲/DELETE** to highlight **Change PIN**, and then press **SELECT**. The telephone base displays **ENTER NEW PIN** and the existing PIN.
4. Use the dialing keys to enter a new 4-digit code.
 - Press **▲/DELETE** to erase a digit.
 - Press and hold **▲/DELETE** to erase all digits.
 - Press **▼CID** or **◀/REPEAT** to move the cursor to the left. Press **▲DIR** or **▶/SKIP** to move the cursor to the right.
5. Press **SET** to save.



Cell ringer

If this feature is on and you have connected an iPhone (iOS 4.1 or later) to your telephone system, the telephone plays your iPhone ringtone when there is incoming call.

1. Press **MENU** on the telephone base in idle mode to enter the main menu.
2. Press **▼CID**, **▲DIR**, **▼/RECORD** or **▲/DELETE** to highlight **Bluetooth**, and then press **SELECT**.
3. Press **▼CID**, **▲DIR**, **▼/RECORD** or **▲/DELETE** to highlight **Cell ringer**, and then press **SELECT**.
 - If there is more than one paired device on the device list, press **▼CID**, **▲DIR**, **▼/RECORD** or **▲/DELETE** to highlight the desired device, and then press **SELECT**.
4. Press **▼CID**, **▲DIR**, **▼/RECORD** or **▲/DELETE** to choose **On** or **Off**, and then press **SET**.

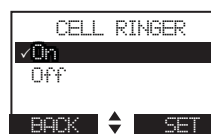

i **NOTE:** The quality of ringtone played on your telephone is subject to individual ringtone characteristics.

Telephone settings

Handset and telephone base settings

Use the menu to change the telephone base or cordless handset settings.

Using a cordless handset:

1. Press **MENU** when the cordless handset is not in use to enter the main menu.
2. Press **▼CID** or **▲DIR** to highlight the feature to be changed. When scrolling through the menu, the selected menu item is highlighted.
3. Press **SELECT** to select the highlighted item.

Using the telephone base:

1. Press **MENU** when the telephone base is not in use to enter the main menu.
2. Press **▼CID**, **▲DIR**, **▼/RECORD** or **▲/DELETE** to highlight the feature to be changed. When scrolling through the menu, the selected menu item is highlighted.
3. Press **SELECT** to select the highlighted item.

 **NOTE:** Press **OFF/CANCEL** on the handset or **CANCEL** on the telephone base to cancel an operation, back up to the previous menu or exit the menu display. Press and hold **OFF/CANCEL** on the handset or **CANCEL** on the telephone base to return to idle mode.

Handset and telephone base settings

Ringer volume

You can select the ringer volume for incoming calls on all lines.

Using a cordless handset:

1. Press **MENU** in idle mode to enter the main menu.
2. Press **▼CID** or **▲DIR** to highlight **Ringers**, and then press **SELECT**.
3. Press **SELECT** to choose **Ringer volume**.
4. Press **▼CID** or **▲DIR** to highlight **All lines, Line 1, Line 2, Cell A, Cell B** or **PC call**, and then press **SELECT**.
5. Press **▼CID** or **▲DIR** to sample each ringer volume.
6. Press **SET** to save. You hear a confirmation tone and the screen returns to the previous menu.

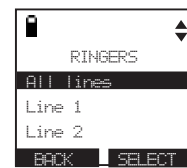

Using the telephone base:

1. Press **MENU** in idle mode to enter the main menu.
2. Press **▼CID**, **▲DIR**, **▼/RECORD** or **▲/DELETE** to highlight **Ringers**, and then press **SELECT**.
3. Press **SELECT** to choose **Ringer volume**.
4. Press **▼CID**, **▲DIR**, **▼/RECORD** or **▲/DELETE** to highlight **All lines, Line 1, Line 2, Cell A, Cell B** or **PC call**, and then press **SELECT**.
5. Press **▼CID**, **▲DIR**, **▼/RECORD** or **▲/DELETE** to sample each ringer volume.
6. Press **SET** to save. You hear a confirmation tone and the screen returns to the previous menu.

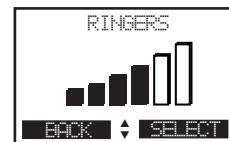
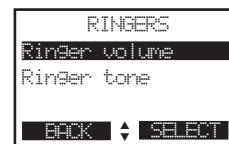
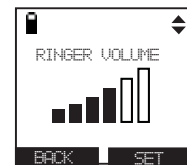

-OR-

1. Press **▼/VOLUME/▲** on the telephone base to set the ringer volume while the telephone base is in idle mode to set the ringer volume of the telephone base.
2. Press **SET** to confirm and you hear a confirmation tone.

i NOTES:

- Changing the handset ringer volume does not affect the base ringer volume.
- If the ringer volume is set to off, that handset is silenced for all incoming calls.
- The ringer volume level also determines the ringer levels of intercom calls (page 73).
- If the ringer volume is set to off, the caller ID will not be announced and the screen will briefly display **Caller ID won't be announced**.

Handset and telephone base settings

Ringer tone

You can select the ringer tones for incoming home and cell calls.

Using a cordless handset:

1. Press **MENU** in idle mode to enter the main menu.
2. Press **▼CID** or **▲DIR** to highlight **Ringers**, and then press **SELECT**.
3. Press **▼CID** or **▲DIR** to highlight **Ringer tone**, and then press **SELECT**.
4. Press **▼CID** or **▲DIR** to highlight **All lines**, **Line 1**, **Line 2**, **Cell A**, **Cell B** or **PC call**, and then press **SELECT**.
5. Press **▼CID** or **▲DIR** to sample each ringer tone. A sample of each ringer tone plays as you scroll through the choices.
6. Press **SELECT** to save. You hear a confirmation tone and the screen returns to the previous menu.

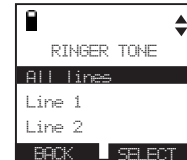

Using the telephone base:

1. Press **MENU** in idle mode to enter the main menu.
2. Press **▼CID**, **▲DIR**, **▼/RECORD** or **▲/DELETE** to highlight **Ringers**, and then press **SELECT**.
3. Press **▼CID**, **▲DIR**, **▼/RECORD** or **▲/DELETE** to highlight **Ringer tone**, and then press **SELECT**.
4. Press **▼CID**, **▲DIR**, **▼/RECORD** or **▲/DELETE** to highlight **All lines**, **Line 1**, **Line 2**, **Cell A**, **Cell B** or **PC call**, and then press **SELECT**.
5. Press **▼CID**, **▲DIR**, **▼/RECORD** or **▲/DELETE** to sample each ringer tone. A sample of each ringer tone plays as you scroll through the choices.
6. Press **SELECT** to save. You hear a confirmation tone and the screen returns to the previous menu.

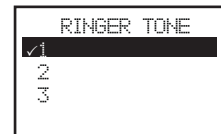
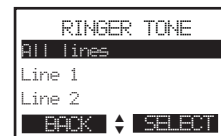

i **NOTE:** When you turn off the ringer volume, you will not hear ringer tone.

Handset and telephone base settings

LCD language

You can select English, French, or Spanish to be used for all screen displays.

Using a cordless handset:

1. Press **MENU** in idle mode to enter the main menu.
2. Press **▼CID** or **▲DIR** to highlight **Settings**, and then press **SELECT**.
3. Press **SELECT** to choose **LCD language**.
4. Press **▼CID** or **▲DIR** to choose from **English, Français** or **Español**, and then press **SELECT**. The screen prompts **Set English/Français/Español as LCD language?**
5. Press **YES** to confirm. You hear a confirmation tone and the screen returns to the previous menu. Press **NO** to cancel the operation.



Using the telephone base:

1. Press **MENU** in idle mode to enter the main menu.
2. Press **▼CID**, **▲DIR**, **▼/RECORD** or **▲/DELETE** to highlight **Settings**, and then press **SELECT**.
3. Press **SELECT** to choose **LCD language**.
4. Press **▼CID**, **▲DIR**, **▼/RECORD** or **▲/DELETE** to choose from **English, Français** or **Español**, and then press **SELECT**. The screen prompts **Set English/Français/Español as LCD language?**
5. Press **YES** to confirm. You hear a confirmation tone and the screen returns to the previous menu. Press **NO** to cancel the operation.



i **NOTE:** If you accidentally change the LCD language to French or Spanish, you can reset it back to English without going through the French or Spanish menus. Press **MENU** on the handset or telephone base in idle mode, and then enter **364#**. To reset the LCD language back to English during a call, press **OPTION** on the handset or telephone base, and then enter **364#**.

Handset and telephone base settings

Set date/time

The answering system announces the day and time of each message prior to playing it. If you subscribe to caller ID service, the day, month and time are set automatically with each incoming call. If you do not want to set the date and time automatically with caller ID information, turn this feature off (see **Use caller ID to automatically set date and time** on page 42). However, the year must be correct so that the day of the week can be calculated from the caller ID information. Before using the answering system, set the date and time as follows.

After handset registration or a power failure, the handset or telephone base will prompt you to set the date and time. Follow the steps below to set the month, day, year and time.

Using a cordless handset:

To set the date and time manually:

1. Press **MENU** in idle mode to enter the main menu.
2. Press **▼CID** or **▲DIR** to highlight **Set date/time**, and then press **SELECT**.
3. Press **▼CID** or **▲DIR** to choose the month, and then press **NEXT**, or enter the 2-digit number using the dialing keys.
4. Press **▼CID** or **▲DIR** to choose the day, and then press **NEXT**, or enter the 2-digit number using the dialing keys.
5. Press **▼CID** or **▲DIR** to choose the year, or enter the 2-digit number using the dialing keys, and then press **NEXT** to move on to set the time.
6. Press **▼CID** or **▲DIR** to choose the hour, and then press **SAVE**, or enter the 2-digit number using the dialing keys.
7. Press **▼CID** or **▲DIR** to choose the minute, and then press **SAVE**, or enter the 2-digit number using the dialing keys.
8. Press **▼CID** or **▲DIR** to highlight **AM** or **PM**, or press **2** for **AM** or **7** for **PM**, and then press **SAVE** to confirm. You hear a confirmation tone and the screen returns to the previous menu.



Handset and telephone base settings

Using the telephone base:

To set the date and time manually:

1. Press **MENU** in idle mode to enter the main menu.
2. Press **▼CID**, **▲DIR**, **▼/RECORD** or **▲/DELETE** to highlight **Set date/time**, and then press **SELECT**.
3. Press **▼CID**, **▲DIR**, **▼/RECORD** or **▲/DELETE** to choose the month, and then press **NEXT**, or enter the 2-digit number using the dialing keys.
4. Press **▼CID**, **▲DIR**, **▼/RECORD** or **▲/DELETE** to choose the day, and then press **NEXT**, or enter the 2-digit number using the dialing keys.
5. Press **▼CID**, **▲DIR**, **▼/RECORD** or **▲/DELETE** to choose the year, or enter the 2-digit number using the dialing keys, and then press **NEXT** to move on to set the time.
6. Press **▼CID**, **▲DIR**, **▼/RECORD** or **▲/DELETE** to choose the hour, and then press **SAVE**, or enter the 2-digit number using the dialing keys.
7. Press **▼CID**, **▲DIR**, **▼/RECORD** or **▲/DELETE** to choose the minute, and then press **SAVE**, or enter the 2-digit number using the dialing keys.
8. Press **▼CID**, **▲DIR**, **▼/RECORD** or **▲/DELETE** to highlight **AM** or **PM**, or press **2** for **AM** or **7** for **PM**, and then press **SAVE** to confirm. You hear a confirmation tone and the screen returns to the previous menu.



i **NOTE:** If the clock is not set when a message is recorded, the system announces, "Time and day not set," before it plays the message.

Handset and telephone base settings

Caller ID announce

The caller ID announce feature lets you know who's calling without having to look at the display. When you have an incoming call, the handset and/or base speaks "Call from..." and the name of the caller based on the directory or caller ID information. If the caller's name is private or unknown, the phone number up to the last 11 digits will be spoken. If the caller's phone number is also private or unknown, no information will be spoken. By default, the caller ID announce feature is programmed **On**.

To turn on/off the caller ID announce:

Using the telephone base:

1. Press **MENU** in idle mode to enter the main menu.
2. Press **▼CID, ▲DIR, ▼/RECORD** or **▲/DELETE** to highlight **Caller ID Annc**, and then press **SELECT**.
3. Press **▼CID, ▲DIR, ▼/RECORD** or **▲/DELETE** to choose **On** or **Off**, and then press **SELECT**. You hear a confirmation tone and the screen shows **CID Annc ON/OFF on all HS & BS** briefly before returning to the previous menu.

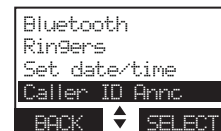

NOTES:

- To use the caller ID announce feature, you must subscribe to caller ID service from your telephone service provider.
- When there are up to five handsets registered, the telephone system supports caller ID announce for all handsets. If six or more handsets are registered, the system supports caller ID announce for the first four registered handsets only.
- This feature does not announce information for call waiting calls.
- When this feature is on, the telephone plays both the caller ID information and the ringer at the same time when there is an incoming call.
- It takes at least two rings for the phone to receive caller ID information and announce it. If the phone is answered before the end of the second ring, the phone won't have time to announce the caller's information.
- Pronunciation of names may vary with this feature. Not all names may be pronounced correctly.
- Caller ID announce is available in English only.
- When this feature is on, the telephone plays both the caller ID information and the ringer at the same time when there is an incoming call.

Handset and telephone base settings

Set speed dial voicemail number

This feature lets you save your voicemail number for easy access when you press and hold the **☑ 1** key.

To set your voicemail number:

Using a cordless handset:

1. Press **MENU** in idle mode to enter the main menu.
2. Press **▼CID** or **▲DIR** to highlight **Settings**, and then press **SELECT**.
3. Press **▼CID** or **▲DIR** to highlight **Voicemail #**, and then press **SELECT**.
4. Press **▼CID** or **▲DIR** to highlight **Line 1** or **Line 2**, and then press **SELECT**.
5. Use the dialing keys to enter the voicemail access number provided by your telephone service provider (up to 30 digits) when prompted.
 - Press **▼CID** or **▲DIR** to move the cursor to the left or right.
 - Press **MUTE/DELETE** to erase a digit.
 - Press and hold **MUTE/DELETE** to erase all digits.
 - Press and hold **REDIAL/PAUSE** to enter a dialing pause (a **p** appears).
6. Press **SAVE** to confirm. There is a confirmation tone and the screen displays **Voicemail # saved** then returns to the previous menu.

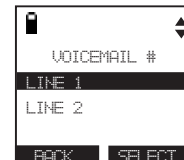
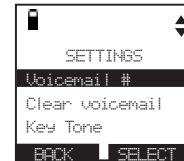

Telephone settings

Handset and telephone base settings

Using a the telephone base:

1. Press **MENU** in idle mode to enter the main menu.
2. Press **▼CID**, **▲DIR**, **▼/RECORD** or **▲/DELETE** to highlight **Settings**, and then press **SELECT**.
3. Press **▼CID**, **▲DIR**, **▼/RECORD** or **▲/DELETE** to highlight **Voicemail #**, and then press **SELECT**.
4. Press **▼CID**, **▲DIR**, **▼/RECORD** or **▲/DELETE** to highlight **Line 1** or **Line 2**, and then press **SELECT**.
5. Use the dialing keys to enter the voicemail access number provided by your telephone service provider (up to 30 digits) when prompted.
 - Press **▼CID** or **◀/REPEAT** to move the cursor to the left. Press **▲DIR** or **▶/SKIP** to move the cursor to the right.
 - Press **▲/DELETE** to erase a digit.
 - Press and hold **▲/DELETE** to erase all digits.
 - Press and hold **REDIAL/PAUSE** on the telephone base to enter a dialing pause (a **p** appears).
6. Press **SAVE** to confirm. There is a confirmation tone and the screen displays **Voicemail # saved** then returns to the previous menu.

Handset and telephone base settings

Voicemail (visual message waiting) number

If you subscribe to a voicemail service offered by your telephone service provider, **New voicemail** and the  icon appear on the telephone base and handset screens when you have new voicemail messages. Contact your service provider for more information and assistance about using your voicemail service.

NOTES:

- This feature does not indicate new messages recorded on your phone's built-in answering system.
- For more information about the difference between your answering system and voicemail, see page 114.

Clear voicemail indication

Use this feature when the telephone indicates there is new voicemail but there is none. For example, when you have accessed your voicemail while away from home. This feature only turns off the displayed **New voicemail** and the  icon; it does not delete your voicemail messages. As long as you have new voicemail messages, your telephone service provider continues to send the signal to turn on the indicator.

To manually turn off the new voicemail indicator:

Using a cordless handset:

1. Press **MENU** in idle mode to enter the main menu.
2. Press **▼CID** or **▲DIR** to highlight **Settings**, and then press **SELECT**.
3. Press **▼CID** or **▲DIR** to highlight **Clear voicemail**, and then press **SELECT**. The screen shows **Reset Voicemail Indication?**
4. Press **YES** to turn the voicemail indicator off. You hear a confirmation tone and the screen returns to the previous menu.

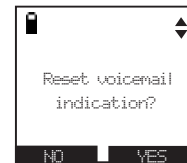

Using the telephone base:

1. Press **MENU** in idle mode to enter the main menu.
2. Press **▼CID**, **▲DIR**, **▼/RECORD** or **▲/DELETE** to highlight **Settings**, and then press **SELECT**.
3. Press **▼CID**, **▲DIR**, **▼/RECORD** or **▲/DELETE** to highlight **Clear voicemail**, and then press **SELECT**. The screen shows **Reset Voicemail Indication?**
4. Press **YES** to turn the voicemail indicator off. You hear a confirmation tone and the screen returns to the previous menu.



NOTES:

- Your telephone service provider voicemail might alert you to new messages with a stutter (broken) dial tone. Contact your telephone service provider for more details.

Handset and telephone base settings

Key tone

The telephone base and handset are set to beep with each key press. You can adjust the key tone volume or turn it off. If you turn off the key tone, there are no beeps when you press keys.

Using a cordless handset:

1. Press **MENU** in idle mode to enter the main menu.
2. Press **▼CID** or **▲DIR** to highlight **Settings**, and then press **SELECT**.
3. Press **▼CID** or **▲DIR** to highlight **Key tone**, and then press **SELECT**.
4. Press **▼CID** or **▲DIR** to select the desired volume or **Off**.
5. Press **SET** to confirm. You hear a confirmation tone and the screen returns to the previous menu.

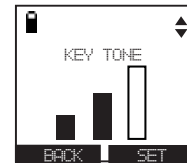
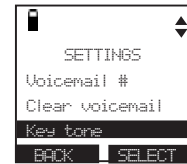

Using the telephone base:

1. Press **MENU** in idle mode to enter the main menu.
2. Press **▼CID** or **▲DIR** to highlight **Settings**, and then press **SELECT**.
3. Press **▼CID** or **▲DIR** to highlight **Key tone**, and then press **SELECT**.
4. Press **▼CID** or **▲DIR** to select the desired volume or **Off**.
5. Press **SET** to confirm. You hear a confirmation tone and the screen returns to the previous menu.

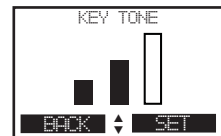
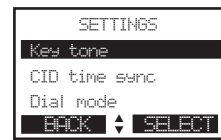

Use caller ID to automatically set date and time

If you subscribe to caller ID service, the date and time will be set automatically by the caller ID information. Follow the steps below to turn the **CID time sync** feature on or off. The default setting is **On**.

Using the telephone base:

1. Press **MENU** in idle mode to enter the main menu.
2. Press **▼CID**, **▲DIR**, **▼/RECORD** or **▲/DELETE** to highlight **Settings**, and then press **SELECT**.
3. Press **▼CID**, **▲DIR**, **▼/RECORD** or **▲/DELETE** to highlight **CID time sync**, and then press **SELECT**.
4. Press **▼CID**, **▲DIR**, **▼/RECORD** or **▲/DELETE** to select **On** or **Off**, and then press **SELECT** to save. You hear a confirmation tone and the screen returns to the previous menu.

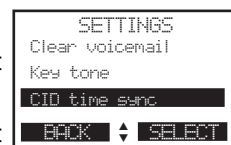

Handset and telephone base settings

Home area code

If you dial seven digits to make a local call (no area code required), enter your area code into the telephone as the home area code. When you receive a call from within your home area code, the caller ID history only displays the seven digits of the telephone number.

This feature makes it easy for you to place a call from the caller ID log. If you dial 10 digits to make a local phone call, do not use this home area code feature. If you do, you cannot place local calls from your caller ID log, as they will have only seven digits.

Using a cordless handset:

1. Press **MENU** in idle mode to enter the main menu.
2. Press **▼CID** or **▲DIR** to highlight **Directory**, and then press **SELECT**.
3. Press **OPTION** to choose **Home**.
4. Press **▼CID** or **▲DIR** to highlight **Home area code**, and then press **SELECT**. The screen briefly shows **Only for 7 digits dialing from Caller ID log**.
5. Use the dialing keys to enter a three-digit home area code.
 - Press **MUTE/DELETE** to erase a digit.
 - Press and hold **MUTE/DELETE** to erase all digits.
 - Press **▼CID** or **▲DIR** to move the cursor to the left or right.
6. Press **SAVE** to confirm. You hear a confirmation tone and the screen shows **Area code will not show in Caller ID log** briefly before returning to the previous menu.



i NOTE:

- If in the future, your telephone service provider requires you to dial ten digits to make a local call (area code plus telephone number), you need to delete your home area code. With the home area code displayed, press and hold MUTE/DELETE on the handset or press and hold ▲/DELETE on the telephone base until the digits are deleted, and then press **SAVE**. The home area code is now restored to its default setting of _ _ _ (empty).

Telephone settings

Handset and telephone base settings

Using the telephone base:

1. Press **MENU** in idle mode to enter the main menu.
2. Press **▼CID, ▲DIR, ▼/RECORD** or **▲/DELETE** to highlight **Directory**, and then press **SELECT**.
3. Press **OPTION** to choose **Home**.
4. Press **▼CID, ▲DIR, ▼/RECORD** or **▲/DELETE** to highlight **Home area code**, and then press **SELECT**. The screen briefly shows **Only for 7 digits dialing from Caller ID log**.
5. Use the dialing keys to enter a three-digit home area code.
 - Press **▲/DELETE** base to erase a digit.
 - Press and hold **▲/DELETE** to erase all digits.
 - Press **▼CID** or **◀/REPEAT** to move the cursor to the left. Press **▲DIR** or **▶/SKIP** to move the cursor to the right.
6. Press **SAVE** to confirm. You hear a confirmation tone and the screen shows **Area code will not show in Caller ID log** briefly before returning to the previous menu.

Handset and telephone base settings

Cell area code

Most cell phone entries are stored in a 10-digit format. If all of your cell phone entries are stored this way, you do not need to program your cell area code.

If your cell phone stores entries in a 7-digit format, we recommend that you program your cell area code so that your 7-digit directory entries can be dialed correctly using your line 1 or line 2.

Using a cordless handset:

1. Press **MENU** in idle mode to enter the main menu.
2. Press **▼CID** or **▲DIR** to highlight **Directory**, and then press **SELECT**.
3. Press **▼CID** or **▲DIR** to highlight a desired downloaded directory, and then press **OPTION**.
4. Press **▼CID** or **▲DIR** to highlight **Cell area code**, and then press **SELECT**. The screen briefly shows **Only for 7 digits dialing from Caller ID log**.
5. Use the dialing keys to enter a three-digit home area code.
 - Press **MUTE/DELETE** to erase a digit.
 - Press and hold **MUTE MUTE/DELETE** to erase all digits.
 - Press **▼CID** or **▲DIR** to move the cursor to the left or right.
6. Press **SAVE** to confirm. You hear a confirmation tone and the screen shows **Area code will not show in Caller ID log** briefly before returning to the previous menu.

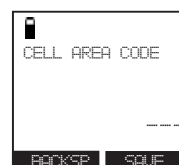

Handset and telephone base settings

Using the telephone base:

1. Press **MENU** in idle mode to enter the main menu.
2. Press **▼CID, ▲DIR, ▼/RECORD** or **▲/DELETE** to highlight **Directory**, and then press **SELECT**.
3. Press **▼CID, ▲DIR, ▼/RECORD** or **▲/DELETE** to highlight a desired downloaded directory, and then press **OPTION**.
4. Press **▼CID, ▲DIR, ▼/RECORD** or **▲/DELETE** to highlight **Cell area code**, and then press **SELECT**. The screen briefly shows **Only for 7 digits dialing from Caller ID log**.
5. Use the dialing keys to enter a three-digit home area code.
 - Press **▲/DELETE** base to erase a digit.
 - Press and hold **▲/DELETE** to erase all digits.
 - Press **▼CID** or **◀/REPEAT** to move the cursor to the left. Press **▲DIR** or **▶/SKIP** to move the cursor to the right.
6. Press **SAVE** to confirm. You hear a confirmation tone and the screen shows **Area code will not show in Caller ID log** briefly before returning to the previous menu.



Handset and telephone base settings

Dial mode

The dial mode is preset to tone dialing. If you have pulse (rotary) service, you must change the dial mode to pulse dialing before using the telephone.

Using the telephone base:

1. Press **MENU** in idle mode to enter the main menu.
2. Press **▼CID, ▲DIR, ▼/RECORD** or **▲/DELETE** to highlight **Settings**, and then press **SELECT**.
3. Press **▼CID, ▲DIR, ▼/RECORD** or **▲/DELETE** to highlight **Dial mode**, and then press **SELECT**.
4. Press **▼CID, ▲DIR, ▼/RECORD** or **▲/DELETE** to choose **Touch-tone** or **Pulse**, and then press **SELECT**. The screen shows **Dial mode is touch-tone** or **Dial mode is pulse**. You hear a confirmation tone and the screen returns to the previous menu.

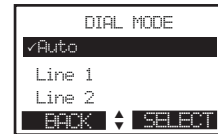

Line preference

The line preference setting determines the default line for the corded handset and speakerphone on a cordless handset and the telephone base for outgoing calls.

Using the telephone base:

1. Press **MENU** in idle mode to enter the main menu.
2. Press **▼CID, ▲DIR, ▼/RECORD** or **▲/DELETE** to highlight **Settings**, and then press **SELECT**.
3. Press **▼CID, ▲DIR, ▼/RECORD** or **▲/DELETE** to highlight **Line preference**, and then press **SELECT**.
4. Press **▼CID, ▲DIR, ▼/RECORD** or **▲/DELETE** to highlight **Auto, Line 1** or **Line 2**, and then press **SELECT**.
5. Press **SELECT** to save. You hear a confirmation tone and the screen returns to the previous menu.

i **NOTE:** If both line 1 and line 2 are in use or on hold, the telephone system will take line 1.

Handset and telephone base settings

QUIET mode

When **QUIET** mode is turned on, the telephone silences all sounds during the set period of time (1-12 hours). However, the handset locator paging tone and any sound-generating operations initiated by users, such as making calls using the speakerphone or setting ringer volume, will sound as normal. After you turn on **QUIET** mode, this feature activates immediately and the answering system turns on automatically.

When **QUIET** mode is on, the answering system takes calls and records messages without broadcasting them.

To turn QUIET mode on:

1. Press and hold **QUIET #** in idle mode to enter the **QUIET** mode setting screen. The screen shows **SET QUIET MODE DURATION (1 to 12 hours) _ _**.
2. Use the dialing keys to enter the desired number of hours (1-12) you would like to turn on **QUIET** mode, and then press **SELECT**. Your screen briefly shows **Answering sys is ON during quiet mode** and then **ZZ** in the idle screen.

To turn QUIET mode off:

- While **QUIET** mode is on, press and hold **QUIET #**. The screen then shows **Quiet mode is off** and you hear a confirmation tone.

i NOTES:

- If you change the base ringer, handset ringer, ringer volume, key tone, or caller ID announce features when **QUIET** mode is on, the sample plays but the feature is still muted after saving the setting.
- After **QUIET** mode is turned off or the set period of time has expired, all muted features will be activated again.
- The **PTT** function is not available when **QUIET** mode is on.

Web address

You can use this feature to view the AT&T website address.

Using a cordless handset:

1. Press **MENU** in idle mode to enter the main menu.
2. Press **▼CID** or **▲DIR** to highlight **Web address**, and then press **SELECT**. The screen shows the AT&T website address.
3. Press **OK** to exit.



Using the telephone base:

1. Press **MENU** in idle mode to enter the main menu.
2. Press **▼CID**, **▲DIR**, **▼/RECORD** or **▲/DELETE** to highlight **Web address**, and then press **SELECT**. The screen shows the AT&T website address.
3. Press **OK** to exit.

Telephone settings

Handset and telephone base settings

No line alert

If there is no telephone line connected to line 1 and/or line 2 of the telephone base, the screens show **L1) No line** and/or **L2) No line**. If you do not want to display this message on the screens (for example, if you use the cell line only), you can turn the No line alert off using the code described below.

To turn off the No line alert:

Press **MENU** on the handset or telephone base in idle mode, and then enter ***662#**. You hear a confirmation tone.

To turn the No line alert back on:

Press **MENU** on the handset or telephone base in idle mode, and then enter ***661#**. You hear a confirmation tone.

Cell alert

If you have downloaded the **Connect to Cell** application and use the **Alerts manager** (page 18), there are message notifications sent to your telephone system. Your telephone system beeps once when your Android cell phone receives text messages, e-mails or social media updates. You can turn the alert tone on or off using the code described below.

To turn the alert tone off:

Press **MENU** on the handset or telephone base in idle mode, and then enter ***252#**. You hear a confirmation tone.

To turn the alert tone back on:

Press **MENU** on the handset or telephone base in idle mode, and then enter ***251#**. You hear a confirmation tone.

Telephone operation

Telephone operation

Make, answer or end a line 1 or line 2 call

The **TL86103** telephone base can be used to make or answer calls on 2 individual landlines. You can connect a maximum of 2 telephone lines to the telephone base.

Using a cordless handset:

To make a call on line 1 or line 2:

Press **LINE 1/FLASH, LINE 2/FLASH** or **☎/SPEAKER**, and then enter the telephone number.

To predial a call on line 1 or line 2:

Enter the telephone number, and then press **LINE 1/FLASH, LINE 2/FLASH** or **☎/SPEAKER**.

To answer a call on line 1 or line 2:

Press **LINE 1/FLASH, LINE 2/FLASH, ☎/SPEAKER**, or **any dialing key (0-9 or TONE ✕)**.

To end a call on line 1 or line 2:

Press **OFF/CANCEL**, or put the cordless handset into the charger.

Using the telephone base:

To make a call on line 1 or line 2:

Press **1 LINE, 2 LINE, SPEAKER ☎**, or lift the corded handset, and then enter the telephone number.

To predial a call on line 1 or line 2:

Enter the telephone number, and then press **1 LINE, 2 LINE** or **☎/SPEAKER**.

To answer a call on line 1 or line 2:

Press **1 LINE, 2 LINE, SPEAKER ☎**, **any dialing key (0-9 or TONE ✕)**, or lift the corded handset.

To end a call on line 1 or line 2:

Press the corresponding cell button, **1 LINE** or **2 LINE**.

-OR-

Press **SPEAKER ☎** or return the corded handset to the telephone base.

NOTES:

- The screen shows the elapsed time as you talk (in hours, minutes and seconds).
- When predialing (preview numbers before dialing), press **MUTE/DELETE** on the handset or **▲/DELETE** on the telephone base to backspace and delete; **press and hold REDIAL/PAUSE** on the handset or **REDIAL/PAUSE** on the telephone base to insert a dialing pause (a p appears).
- You cannot answer a call on line 1 or line 2 using your connected cell phone.

Telephone operation

Telephone operation

Using a Bluetooth, headset, DECT headset or a wireless speaker:

You can use a Bluetooth headset, a DECT headset or a wireless speaker for calls on line 1 or line 2. However, you need to keep the device within 15 feet of the telephone base for optimal performance. Please see the user's manual of your Bluetooth headset for more information of Bluetooth headset.

To answer or end a call on line 1 or line 2 using a Bluetooth headset:

Press the call key on your bluetooth headset.

To answer or end a call on line 1 or line 2 using a DECT headset:

Press **ON/OFF** on your DECT headset.

To answer or end a call on line 1 or line 2 using a Wireless speaker:

Press **PHONE** on your wireless speaker.

If you make or answer a call on line 1 or line 2 on a handset, you can transfer the call to your headset. The handset remains active, but the handset earpiece and microphone are muted. If you hang up the handset, the call ends.

To transfer a call from a handset to a Bluetooth headset:

Using the telephone base:

- Press **OPTION** during a call on line 1 or line 2.
- Press **▼CID, ▲DIR, ▼/RECORD** or **▲/DELETE** to highlight **Use BT headset**, and then press **SELECT**. The telephone base displays **Transferring audio to Headset A**, the message disappears if the call is successfully transferred to the Bluetooth headset.

To transfer a call from a handset to a DECT headset or a wireless speaker:

Using a cordless handset or the telephone base:

- Press **OPTION** during a call on line 1 or line 2.
- Press **▼CID** or **▲DIR** on a handset, or **▼CID, ▲DIR, ▼/RECORD** or **▲/DELETE** on the telephone base, to highlight **Intercom**, and then press **SELECT**.
- Press **▼CID** or **▲DIR** on a handset, or **▼CID, ▲DIR, ▼/RECORD** or **▲/DELETE** on the telephone base, to highlight **<HDST/SPK X>**, and then press **SELECT**.
- Press **▼CID** or **▲DIR** on a handset, or **▼CID, ▲DIR, ▼/RECORD** or **▲/DELETE** on the telephone base, to highlight **Transfer**, and then press **SELECT**.

Telephone operation

Telephone operation

To transfer a call from the Bluetooth/DECT headset or wireless speaker back to the handset:

Using the telephone base:

- Press **OPTION**, and then press **▼CID, ▲DIR, ▼/RECORD** or **▲/DELETE** to highlight **Use handset** and press **SELECT**.

To end a call that started at the handset:

Using a cordless handset:

Press **OFF/CANCEL**, or put the cordless handset into the charger.

Call waiting on line 1 or line 2

If you subscribe to call waiting service from your telephone service provider, you hear a tone if someone calls while you are already on a call.

- Press the corresponding line button, **LINE 1/FLASH** or **LINE 2/FLASH** on the handset, or press **FLASH** on the telephone base to put your current call on hold and take the new call.
- Press the same key at any time to switch back and forth between calls.

Telephone operation

Telephone operation

Make, answer or end a cell call

The **TL86103** can be used to make or answer calls on the cell line. You can connect a maximum of 2 Bluetooth enabled cell phones to the telephone base. Both cell phones can be used on cell calls at the same time.

Using a cordless handset:

To make a cell call:

1. Press **☎A Cell** or **☎B Cell**, and then enter the telephone number.
2. Press **DIAL** or **📞/SPEAKER**.

To predial a cell call:

Enter the telephone number, and then press **☎A Cell** or **☎B Cell**.

To answer a cell call:

Press **📞/SPEAKER**, **☎A Cell** or **☎B Cell**.

To end a cell call:

Press **OFF/CANCEL**, or put the cordless handset into the charger.

Using the telephone base:

To make a cell call:

1. Press **Cell A☎** or **Cell B☎**, and then enter the telephone number.
2. Press **DIAL** or **SPEAKER 📞**, or lift the corded handset.

To predial a cell call:

Enter the telephone number, and then press **Cell A☎** or **Cell B☎**.

To answer a cell call:

Press **SPEAKER 📞**, **Cell A☎** or **Cell B☎**, or lift the corded handset.

To end a cell call:

Press the corresponding cell button, **Cell A☎** or **Cell B☎**.

-OR-

Press **SPEAKER 📞** or return the corded handset to the telephone base.



NOTES:

- You can also use your cell phone to answer the call. If you answer with your cell phone, it disconnects from the telephone base.
- If you do not want to answer the call, press **REJECT**.
- When you try to make a cell call but your cell phone is not connected to the base, the telephone base displays **Cellular phone not connected. Please connect to proceed**. Press **CONNECT** on the telephone base to connect your cell phone to the telephone system. Refer to **Bluetooth connection from idle mode** on page 25 and **Connect/disconnect an active device** on page 26.

Telephone operation

Call waiting on the cell line

If you subscribe to call waiting service from your cell phone service provider, you hear a beep if someone calls while you are already on a call.

To answer the incoming call from the same cell line:

Using a cordless handset:

- Press **SWAP**, **A Cell** or **B Cell** on the handset. The original call is put on hold and you take the new call.
- Press **OPTION** on the handset. Press **▼CID** or **▲DIR** to highlight **Swap**. Press **SELECT** to resume the original call. The other incoming cell call is put on hold.

-OR-

Using the telephone base:

- Press **SWAP**, **Cell A** or **Cell B** on the telephone base. The original call is put on hold and you take the new call.
- Press **OPTION** on the telephone base. Press **▼CID** or **▲DIR** to highlight **Swap**. Press **SELECT** to resume the original call. The other incoming cell call is put on hold.

To answer the incoming call from the a different cell line:

Using a cordless handset:

- Press **A Cell** or **B Cell** to put your current call on hold and take the new call.
- Press **A Cell** or **B Cell** at any time to switch back and forth between calls.

Using the telephone base:

- Press **Cell A** or **Cell B** to put your current call on hold and take the new call.
- Press **Cell A** or **Cell B** at any time to switch back and forth between calls.





NOTE:

- If you do not want to answer the incoming call from a different cell line, press **REJECT**.

Telephone operation



Telephone operation

Answer an incoming cell call while on line 1 or line 2



If you are on a call using line 1 or line 2 and you receive an incoming cell call, you hear a beep and ,  B, or  B displays on the cordless handset or telephone base you are using. The telephone base and all other handsets ring.

To answer the incoming cell call:

Using a cordless handset:

Press  **A Cell** or  **B Cell** to answer the incoming cell call. The call on line 1 or line 2 is automatically placed on hold, all other handsets and the telephone base display **L1) On hold** and/or **L2) On hold**. At the same time, the screens will display **CL) A In use**, **CL) B In use**, or **CL) A&B In use**.

Using the telephone base:



Press **Cell A**  or **Cell B**  to answer the incoming cell call. The call on line 1 or line 2 is automatically placed on hold, all handsets and the telephone base display **L1) On hold** and/or **L2) On hold**. At the same time, the screens will display **CL) A In use**, **CL) B In use**, or **CL) A&B In use**.

To end the cell call:

Using a cordless handset:

Press **OFF/CANCEL**. Line 1 or line 2 is still on hold. The telephone base and all other handsets display **L1) On hold** and/or **L2) On hold**.

Using the telephone base:

Press **Cell A**  or **Cell B** . Line 1 or line 2 is still on hold. All handsets display **L1) On hold** and/or **L2) On hold**.

To resume the call on line 1 or line 2 On hold:

Using a cordless handset:

Press **LINE 1/FLASH** or **LINE 2/FLASH** on the handset.

Using the telephone base:

Press **1 LINE** or **2 LINE** on the telephone base.

Telephone operation

Answer an incoming call on line 1 or line 2 while on a cell call

If you are on a cell call and you receive an incoming call on line 1 or line 2, you hear a beep, and then **1 2**, **2 2**, or **1 2 2**, and **Incoming call** displays on the handset or telephone base you are using. The telephone base and all other handsets ring.

To answer the incoming call on line 1 or line 2:

Using a cordless handset:

Press **LINE 1/FLASH** or **LINE 2/FLASH** on the cordless handset to answer the incoming call on line 1 or line 2. The cell call is automatically placed on hold. All screens display **CL) A On hold**, **CL) B On hold**, or **CL) A&B On hold**. At the same time, the screens will display **L1) In use** and/or **L2) In use**.

Using the telephone base:

Press **1 LINE** or **2 LINE** on the telephone base to answer the incoming call on line 1 or line 2. The cell call is automatically placed on hold. All screens display **CL) A On hold**, **CL) B On hold**, or **CL) A&B On hold**. At the same time, the screens will display **L1) In use** and/or **L2) In use**.

To end the call on line 1 or line 2:

Using a cordless handset:

Press **OFF/CANCEL** on the cordless handset. The cell line is still on hold. All devices display **CL) A On hold**, **CL) B On hold**, or **CL) A&B On hold**.

Using the telephone base:

Press **1 LINE** or **2 LINE** on the telephone base. The cell line is still on hold. All devices display either **CL) A On hold**, **CL) B On hold**, or **CL) A&B On hold**.

To resume the cell call On hold:

Using a cordless handset:

Press **(P)A Cell** or **(P)B Cell** on the handset.

Using the telephone base:

Press **Cell A(P)** or **Cell B(P)** on the telephone base.

i NOTE: If you have turned on your answering system and you do not answer the incoming call on line 1 or line 2, the call is answered by your answering system.

Telephone operation

Telephone operation

Make, answer or end a softphone call

You can receive or make calls on the traditional landlines, cell lines, or VoIP calls through Skype or Microsoft Lync when the phone system base is connected to the **AT&T Unified Call Manager** software installed on your computer.

Install the **AT&T Unified Call Manager** using the **CD-ROM** provided in the package (see page 11). For detailed installation and operation instructions of the software, refer to the **Installation and Operation Guide** which can also be found in the **CD-ROM** provided.

To make a softphone call:

Using a cordless handset or the telephone base:

1. Enter the telephone number in idle mode.
2. Press **PC CALL** to dial a softphone call.

To answer the incoming softphone call:

Using a cordless handset:

Press **ANSWER** or **SPEAKER** to answer the incoming softphone call.

Using the telephone base:

Press **SPEAKER** or lift the corded handset to answer the incoming softphone call.

To hold a softphone call:

Using a cordless handset or the telephone base:

Press **HOLD** to hold the softphone line. The screen displays **PC CALL ON HOLD**. Press **PC CALL** to resume the call.

To end a softphone call:

Using a cordless handset:

Press **OFF/CANCEL**, or put the cordless handset into the charger.

Using the telephone base:

Press **SPEAKER** or return the corded handset to the telephone base.



NOTES:

- During an incoming call, the screens display **Skype and Lync** without any specific details about the name and number of the caller. If the caller ID announce (page 38) is turned on, the telephone will announce **Call from Skype** or **Call from Lync**.
- If you do not want to answer the call, press **REJECT**.
- Missed call from softphone is logged in the caller ID log of the telephone system. **Skype** or **Lync** is stored as the name of the caller id log entry.
- The cordless handset or the telephone base screens display \mathcal{P}_C when the ringer of PC call is turned off.

Telephone operation

Telephone operation

Voice command

TL86103 supports voice command recognition (VR) when the phone system is connected to **AT&T Unified Call Manager** at PC (see page 11). You can make calls through the voice command (name dialing) function using cordless handset, telephone base, DECT headset or wireless speaker while the phone system is idle and all lines are not in use.

To make a call using voice command:

Using a cordless handset:

1. Press **MENU** in idle mode.
2. Press **▼CID** or **▲DIR** to highlight **Voice Command**, and then press **SELECT**. The screen displays **Processing Voice command...**
3. Speak the name of a directory entry to dial.

Using the telephone base:

1. Press **MENU** in idle mode.
2. Press **▼CID**, **▲DIR**, **▼/RECORD** or **▲/DELETE** to highlight **Voice Command**, and then press **SELECT**. The screen displays **Processing Voice command...**
3. Speak the name of a directory entry to dial.



NOTES:

- When there is an incoming call from any line, the VR will be stopped immediately.
- To say a command again when processing, press **STOP** and select **Voice Command** again from the menu.
- If the voice command setting is set "**Disable**" in the **AT&T Unified Call Manager**, voice command requests will be rejected.

Conference calls

Conference calls on line 1 and line 2

While you are on a call on line 1, and line 2 is on hold or in use, you can conference line 1 and line 2 using a handset or telephone base.

To conference both line 1 and line 2:

Using a cordless handset:

1. Press **OPTION**.
2. Press **▼CID** or **▲DIR** to highlight **Conference**.
3. Press **SELECT**. The conferencing device's screen displays **Conf**.

Using the telephone base:

1. Press **OPTION**.
2. Press **▼CID**, **▲DIR**, **▼/RECORD** or **▲/DELETE** to highlight **Conference**.
3. Press **SELECT**. The conferencing device's screen displays **Conf**.

To select an option while on a conference call:

Using a cordless handset:

1. Press **OPTION**.
2. Press **▼CID** or **▲DIR** to highlight one of the following options:
 - **End Line 1**
 - **End Line 2**
 - **Equalizer**
 - **Caller ID log**
 - **Directory**
3. Press **SELECT**.

Using the telephone base:

1. Press **OPTION**.
2. Press **▼CID**, **▲DIR**, **▼/RECORD** or **▲/DELETE** to highlight one of the following options:
 - **End Line 1**
 - **End Line 2**
 - **Equalizer**
 - **Caller ID log**
 - **Directory**
3. Press **SELECT**.



NOTE: The option 'Use BT headset' will appear in the options menu on the telephone base if there is an active headset in the Bluetooth device list.

Telephone operation

Conference calls

To end a conference call:

Using a cordless handset:

Press **OFF/CANCEL**, or put the cordless handset into the charger. The call continues until all people hang up.

Using the telephone base:

Press **1 LINE**, **2 LINE**, or put the corded handset back to the telephone base. The call continues until all people hang up.

Conference calls on line 1 or line 2 with cell calls

When you have calls established on line 1 or line 2, and the cell line, you can create a 3-way conference.

To conference line 1 or line 2 with cell calls:

Using a cordless handset:

1. Press **OPTION**.
2. Press **▼CID** or **▲DIR** to highlight **Conference**.
3. Press **SELECT**. The conferencing device's screen displays **Conf**.

Using the telephone base:

1. Press **OPTION**.
2. Press **▼CID**, **▲DIR**, **▼/RECORD** or **▲/DELETE** to highlight **Conference**.
3. Press **SELECT**. The conferencing device's screen displays **Conf**.

To select an option while on a conference call:

Using a cordless handset:

1. Press **OPTION**.
2. Press **▼CID** or **▲DIR** to highlight one of the following options:
 - End Line 1/2
 - End Cell A/B line
 - Equalizer
 - Caller ID log
 - Directory
3. Press **SELECT**.

Telephone operation
Conference calls

Using the telephone base:

1. Press **OPTION**.
2. Press **▼/CID**, **▲/DIR**, **▼/RECORD** or **▲/DELETE** to highlight one of the following options:
 - **End Line 1/2**
 - **End Cell A/B line**
 - **Equalizer**
 - **Caller ID log**
 - **Directory**
3. Press **SELECT**.



NOTE: The option 'Use BT headset' will appear in the options menu on the telephone base if there is an active headset in the Bluetooth device list.

To end a conference call:

Using a cordless handset:

Press **OFF/CANCEL**, or put the cordless handset into the charger. The call continues until all people hang up.

Using the telephone base:

Press **1 LINE**, **2 LINE**, **Cell A** (📶), **Cell B** (📶), or put the corded handset back to the telephone base. The call continues until all people hang up.

Using line 1 or line 2 and cell lines together:

- You can be on two different calls at the same time using a cell line and line 1 or line 2 with two handsets.
- You can be on a call using the cell line and a Bluetooth headset via line 1 or line 2 at the same time.
- If you are on a call using the cell line, you cannot join the call using your paired cell phone. However, you can join the call using another **TL86103** device. Your cell phone is being used for the phone call so only features that are normally available during a call can be used.

Telephone operation

Options while on calls

Silencing the ringer

When the telephone is ringing, you can temporarily silence the ringer of the handset or telephone base without disconnecting the call. The next call rings normally at the preset volume.

To silence the handset ringer:

Using a cordless handset:

Press **SILENCE**, **OFF/CANCEL**, **MUTE/DELETE** or **QUIET #**. The handset screen shows **Ringer muted**.

To silence the base ringer:

Using the telephone base:

Press **SILENCE**, **CANCEL** or **QUIET #**. The telephone base screen shows **Ringer muted**.

Page all devices

This feature helps you find the misplaced devices.

To start paging:

Using the telephone base:

1. Press **MENU** in idle mode.
2. Press **Page all devices**, and then press **SELECT** to start the paging tone on all handsets for 60 seconds. All idle handsets ring and display **** Paging ****

To stop the paging tone on a cordless handset:

Press **SILENCE**, **MUTE/DELETE**, **QUIET #** or **OFF/CANCEL**.

To end paging:

Using a cordless handset:

Press **STOP** on the telephone base, or **LINE 1/FLASH**, **LINE 2/FLASH**, **🔊/SPEAKER**, or any dialing key (**0-9** or **TONE ✕**) on the handset.

Using the telephone base:

Press **1 LINE**, **2 LINE**, **CANCEL** or **QUIET #** on the telephone base.



NOTES:

- If the handset ringer volume is set to off, the handset still rings when paged.
- If there is no response after 60 seconds, the paging ends.

Options while on calls

Speakerphone

If you are on speakerphone,  displays on the handset or telephone base you are using.

Using a cordless handset:

During a call, press /SPEAKER on the cordless handset to switch between the speakerphone and normal cordless handset use.

Using a corded handset:

During a call, press **SPEAKER**  on the telephone base to switch between the speakerphone and normal corded handset use.

Using the telephone base:

During a call, press **SPEAKER**  on the telephone base to end a call.

Join a call in progress

Another handset can join you on an outside call. The call continues until all people hang up. You can share an outside call with telephone base and up to 4 system handsets.

To join a call on line 1 or line 2:

Using a cordless handset:



Press **LINE 1/FLASH**, **LINE 2/FLASH** or /SPEAKER on another handset to join the call.

Using the telephone base:

Press **1 LINE**, **2 LINE** or **SPEAKER**  to join the call.

To join a cell call:

Using a cordless handset:

Press  **A CELL** or  **B CELL** on another handset to join the call.

Using the telephone base:

Press **Cell A**  or **Cell B**  to join the call.

Options while on calls

Volume control

While on a call, you can adjust the listening volume on the handset or telephone base.

If it is a cell call and the volume is too loud, too quiet or drops out, try changing the volume on your cell phone. On some cell phones, changing the volume on the cell phone affects your cell call volume on a **TL86103** cordless handset or telephone base.

To adjust the listening volume of a cordless handset:

Press **▼CID/VOLUME** or **▲DIR/VOLUME** while on a call.

To adjust the listening volume of the telephone base:

Press **▼/VOLUME/▲** while on a call.

 **NOTE:** The handset earpiece volume setting (1-6) and speakerphone volume setting (1-6) are independent. The speakerphone volume setting of the telephone base (1-8) is also independent.

Mute

Use the mute function to turn off the microphone. You can hear the caller, but the caller cannot hear you.

Using a cordless handset:

To mute a call:

While on a call, press **MUTE/DELETE** on the handset. When mute is on, the handset screen shows **Microphone off** for a few seconds and the **MUTE** icon appears until the mute function is turned off.

To take a call off mute:

Press **MUTE/DELETE** on the handset and resume speaking, the **MUTE** icon disappears, and the screen shows **Microphone on** for a few seconds. Mute is automatically canceled when you end the call.

Using the telephone base:

To mute a call:

While on a call, press **MUTE** on the telephone base. When mute is on, the handset screen shows **Microphone off** for a few seconds and the **MUTE** icon appears until the mute function is turned off.

To take a call off mute:

Press **MUTE** on the telephone base and resume speaking, the **MUTE** icon disappears, and the screen shows **Microphone on** for a few seconds. Mute is automatically canceled when you end the call.

Options while on calls

Temporary tone dialing

If you have pulse (rotary) service only, you can switch from pulse to touch-tone dialing temporarily during a call. This is useful if you need to send touch-tone signals to access your telephone banking or long distance services.

During a call:

1. Press **TONEX** on the handset or telephone base.
2. Use the dialing keys to enter the desired number. The telephone sends touch-tone signals.
3. The telephone automatically returns to pulse dialing after you end the call.

Hold

You can place any call on hold. You hear an alert tone at the telephone base if you have not taken the call off of hold after 14 minutes. You hear another alert tone at the telephone base 30 seconds later. At 15 minutes on hold, the call on hold automatically disconnects.

To place a call on line 1 or line 2 On hold:

- Press **HOLD** on a handset or the telephone base. **L1) On hold** and/or **L2) On hold** appears on the handsets and telephone base. **1**, **2**, or **1 2** flashes on the screens of handsets and the telephone base.

To resume a call on line 1 or line 2 On hold:

- Press **LINE 1/FLASH** or **LINE 2/FLASH** on handsets, or **1 LINE** or **2 LINE** on the telephone base.

To place a cell call On hold:

- Press **HOLD** on the handset or the telephone base. **CL) A On hold**, **CL) B On hold**, or **CL) A&B On hold** appears on the handsets and telephone base. **A**, **B**, or **A B** flashes on the screens of handsets and the telephone base.

To resume a cell call On hold:

- Press **A CELL** or **B CELL** on the handset or **CELL A** or **CELL B** on the telephone base.

Options while on calls

Equalizer

The equalizer feature enables you to change the audio quality to best suit your hearing.

Using a cordless handset:

1. While on a call on line 1 or line 2 or cell call, press **OPTION**.
2. Press **▼CID** or **▲DIR** to highlight **Equalizer**, and then press **SELECT**.
3. Press **▼CID** or **▲DIR** to select **Treble 1**, **Treble 2**, **Bass** or **Natural** (the default setting), and then press **SELECT**.

Using the telephone base:

1. While on a call on line 1 or line 2 or cell call, press **OPTION**.
2. Press **▼CID**, **▲DIR**, **▼/RECORD** or **▲/DELETE** to highlight **Equalizer**, and then press **SELECT**.
3. Press **▼CID**, **▲DIR**, **▼/RECORD** or **▲/DELETE** to select **Treble 1**, **Treble 2**, **Bass** or **Natural** (the default setting), and then press **SELECT**.



NOTES:

- If you switch the call between the cordless handset and speakerphone pressing **◀)/SPEAKER**, or between the corded handset and speakerphone by or **SPEAKER ▶)**, the audio setting remains unchanged.
- The current equalizer setting remains unchanged until a new setting is selected.

Options while on calls

Chain dialing

Use this feature to initiate a dialing sequence from numbers stored in the directory, caller ID log or redial list while you are on a call.

Chain dialing can be useful if you wish to access other numbers (such as bank account numbers or access codes) from the directory, caller ID log or redial list.

To access a number in the directory while on a call:

Using a cordless handset:

To access the directory while on a call:

1. Press **OPTION**.
2. Press **▼CID** or **▲DIR** to highlight **Directory**, and then press **SELECT**.
3. Press **▼CID** or **▲DIR** to highlight the desired directory, and then press **REVIEW**.
4. Press **▼CID** or **▲DIR** to highlight the desired entry or perform an alphabetical search (page 92).
5. Press **DIAL** to dial the number shown.

To access the caller ID log while on a call:

1. Press **OPTION**.
2. Press **▼CID** or **▲DIR** to highlight **Caller ID log**, and then press **SELECT**.
3. Press **▼CID** or **▲DIR** to highlight the desired number.
4. Press **CALL** to dial the number shown.

To access the redial list while on a call:

1. Press **REDIAL/PAUSE** to show the most recently dialed number.
2. Press **▼CID** or **▲DIR** to highlight the desired number.
3. Press **DIAL** to dial the number shown.

Telephone operation

Options while on calls

Using the telephone base:

To access the directory while on a call:

1. Press **OPTION**.
2. Press **▼CID, ▲DIR, ▼/RECORD** or **▲/DELETE** to highlight **Directory** and then press **SELECT**.
3. Press **▼CID, ▲DIR, ▼/RECORD** or **▲/DELETE** to highlight the desired directory, and then press **REVIEW**.
4. Press **▼CID, ▲DIR, ▼/RECORD** or **▲/DELETE** to highlight the desired entry. Press **DIAL** to dial the number shown.

To access the caller ID log while on a call:

1. Press **OPTION**.
2. Press **▼CID, ▲DIR, ▼/RECORD** or **▲/DELETE** to highlight **Caller ID log**, and then press **SELECT**.
3. Press **▼CID, ▲DIR, ▼/RECORD** or **▲/DELETE** to highlight the desired number.
4. Press **CALL** to dial the number shown.

To access the redial list while on a call:

1. Press **REDIAL/PAUSE** to show the most recently dialed number.
2. Press **▼CID, ▲DIR, ▼/RECORD** or **▲/DELETE** to highlight the desired number.
3. Press **DIAL** to dial the number shown.

NOTES:

- You cannot edit a directory entry while on a call. For more details about the directory, see pages 85-86.
- You cannot copy a caller ID entry into the directory while on a call. For more details about the caller ID log, see pages 96-95.
- If you press **REDIAL/PAUSE** on a cordless handset while on a call, you can only view the ten most recently dialed numbers but you cannot erase the entries. If you press **REDIAL/PAUSE** on the telephone base while on a call, you can delete the entries by pressing **▲/DELETE**. For more details about the redial memory, see pages 69-72.
- Press **OFF/CANCEL** on a cordless handset or **CANCEL** on the telephone base to exit redial, directory or caller ID log when on a call.

Redial

The telephone base and each cordless handset store the last 10 dialed numbers (up to 30 digits each) in the redial list. The redial entries of each cordless handset and the telephone base are independent.

Review the redial list

Using a cordless handset:

1. Press **REDIAL/PAUSE** in idle mode.
2. Press **▼CID**, **▲DIR** or **REDIAL/PAUSE** repeatedly to browse until the desired number displays. The handset beeps twice at the end of the list.

Press **OFF/CANCEL** to exit.

Using the telephone base:

1. Press **REDIAL/PAUSE** in idle mode.
2. Press **▼CID**, **▲DIR**, **▼/RECORD** or **▲/DELETE** or **REDIAL/PAUSE** repeatedly to browse until the desired number displays. The telephone base beeps twice at the end of the list.

Press **CANCEL** to exit.



Dial a redial entry

Using a cordless handset:



1. Press **REDIAL/PAUSE** in idle mode.
2. Press **▼CID**, **▲DIR** or **REDIAL/PAUSE** repeatedly to browse until the desired number displays. The handset beeps twice at the end of the list.
3. Press **LINE 1/FLASH**, **LINE 2/FLASH** or **◀/SPEAKER** to dial using line 1 or line 2, or press **ⓂA Cell** or **ⓂB Cell** to dial using the cell line.

-OR-



1. Press **LINE 1/FLASH**, **LINE 2/FLASH** or **◀/SPEAKER** to dial using line 1 or line 2, or press **ⓂA Cell** or **ⓂB Cell** to dial using the cell line, and then press **REDIAL/PAUSE**.
2. Press **▼CID**, **▲DIR** or **REDIAL/PAUSE** repeatedly to browse until the desired number displays. The handset beeps twice at the end of the list.
 - If you are using the cell line, press **INSERT** to select the desired number.
3. Press **DIAL** to dial the number displayed.

Redial

Using the telephone base:

1. Press **REDIAL/PAUSE** in idle mode.
2. Press **▼CID, ▲DIR, ▼/RECORD** or **▲/DELETE** to browse until the desired number displays. The telephone base beeps twice at the end of the list.
3. Press **LINE 1, LINE 2** or **SPEAKER** ) to dial using line 1 or line 2, or press **Cell A** ) or **Cell B** ) to dial using the cell line.

-OR-

1. Press **LINE 1, LINE 2** or **SPEAKER** ) to dial using line 1 or line 2, or press **Cell A** ) or **Cell B** ) to dial using the cell line, and then press **REDIAL/PAUSE**.
2. Press **▼CID, ▲DIR, ▼/RECORD** or **▲/DELETE**, or **REDIAL/PAUSE** repeatedly to browse until the desired number displays. The handset beeps twice at the end of the list.
 - If you are using the cell line, press **INSERT** to select the desired number.
3. Press **DIAL** to dial the number displayed.



NOTES:

- You can enter the area code in idle mode first, and then use the instructions above to highlight the desired entry, and press **INSERT**. The area code will be added in front of the selected redial number.

Save a redial entry to the directory

Using a cordless handset:

1. Press **REDIAL/PAUSE** in idle mode.
2. Press **▼CID**, **▲DIR**, or **REDIAL/PAUSE** repeatedly to browse until the desired number displays.
3. Press **SAVE**.
4. The handset displays **EDIT NUMBER**. Use the dialing keys to edit the number, if necessary.
 - Press **MUTE/DELETE** to erase a digit.
 - Press and hold **MUTE/DELETE** to erase all digits.
 - Press **▼CID** or **▲DIR** to move the cursor to the right or left.
 - Press and hold **REDIAL/PAUSE** to insert a dialing pause (a **p** appears).
5. Press **NEXT**.
6. Press **▼CID**, **▲DIR** to select one of the following types:
 - Home
 - Cell
 - Work
 - Other
7. Press **NEXT**. The screen displays **ENTER NAME**. Use the dialing keys (page 88) to enter a name.
 - Press **MUTE/DELETE** to erase a character.
 - Press and hold **MUTE/DELETE** to erase all characters.
 - Press **▼CID** or **▲DIR** to move the cursor to the right or left.
8. Press **SAVE**. The screen displays **Saved**. You hear a confirmation tone.

Redial

Using the telephone base:

1. Press **REDIAL/PAUSE** in idle mode.
2. Press **▼CID**, **▲DIR**, **▼/RECORD**, **▲/DELETE**, or **REDIAL/PAUSE** repeatedly to browse until the desired number displays.
3. Press **SAVE**.
4. The handset displays EDIT NUMBER. Use the dialing keys to edit the number, if necessary.
 - Press **▲/DELETE** to erase a digit.
 - Press and hold **▲/DELETE** to erase all digits.
 - Press **▼CID** or **◀/REPEAT** to move the cursor to the left. Press **▲DIR** or **▶/SKIP** to move the cursor to the right.
 - Press and hold **REDIAL/PAUSE** to insert a dialing pause (a **p** appears).
5. Press **NEXT**.
6. Press **▼CID**, **▲DIR**, **▼/RECORD** or **▲/DELETE** to highlight one of the following types:
 - Home
 - Cell
 - Work
 - Other
7. Press **NEXT**. The screen displays **ENTER NAME**. Use the dialing keys (page 88) to enter a name.
 - Press **▲/DELETE** to erase a character.
 - Press and hold **▲/DELETE** to erase all characters.
 - Press **▼CID** or **◀/REPEAT** to move the cursor to the left. Press **▲DIR** or **▶/SKIP** to move the cursor to the right.
8. Press **SAVE**. The screen displays **Saved**. You hear a confirmation tone.

Delete a redial entry from the directory

Using a cordless handset:

1. Press **REDIAL/PAUSE** in idle mode.
2. Press **▼CID** or **▲DIR** or **REDIAL/PAUSE** repeatedly to browse until the desired number displays.
3. Press **MUTE/DELETE** to delete the displayed number. You hear a confirmation tone.

Using a the telephone base:

1. Press **REDIAL/PAUSE** in idle mode.
2. Press **▼CID**, **▲DIR**, **▼/RECORD**, **▲/DELETE**, or **REDIAL/PAUSE** repeatedly to browse until the desired number displays.
3. Press **▲/DELETE** or **DELETE** to delete the displayed number. You hear a confirmation tone.

Multiple handset use
Intercom

Use the intercom feature for conversations between two devices, or a device and the telephone base. You can buy additional expansion handsets (model AT&T **TL86003**) for this telephone base to expand your telephone system (up to 12 handsets).

To initiate, answer, and end an intercom call:

Using a cordless handset:

1. Press **MENU** in idle mode to enter the main menu. Press **▼CID** or **▲DIR** to highlight **Intercom**, and then press **SELECT**.

- If you have one handset, the handset shows **Calling base**.
- If you have more than one handset, the handset shows **INTERCOM TO:** Use the dialing keys to enter a specific device number (**0** for the telephone base, **1-9** for handsets 1-9, **TONE*** followed by **0-2** for handsets 10-12, **TONE*** followed by **#** for all devices; **#** for a single DECT headset, **#** followed by **1** or **2** for DECT headset/speaker 1 or DECT headset/speaker 2 respectively), or press **▼CID** or **▲DIR** to highlight the desired device and press **SELECT**. Your handset screen shows **Calling HANDSET X**, **Calling Base** or **Calling all**.

The destination device(s) rings and shows **HANDSET X is calling** or **HANDSET X is calling all** (**HANDSET** represents the handset name, **X** represents the handset number).

2. To answer the intercom call, press **LINE 1/FLASH**, **LINE 2/FLASH**, **📞/SPEAKER**, **📞A CELL**, **📞B CELL**, any dialing key (**0-9**, **TONE***), or press **ANSWER** on the destination handset. Both devices now show **Intercom**.
3. To end the intercom call, press **END**, **OFF/CANCEL**, or put the cordless handset into the charger; or press **END** on the telephone base. Both devices display **Intercom ended**.

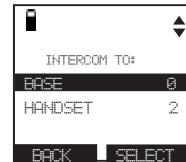

Multiple handset use
Intercom

Using the telephone base:

1. Press **MENU** in idle mode to enter the main menu. Press **▼CID**, **▲DIR**, **▼/RECORD**, or **▲/DELETE** to highlight **Intercom**, and then press **SELECT**.

- If you have one handset, the telephone base shows **Calling HANDSET X**.

- If you have more than one handset, the telephone base shows **INTERCOM TO:** Use the dialing keys to enter a specific handset number (**1-9** for handsets 1-9, **TONEX** followed by **0-2** for handsets 10-12, **TONEX** followed by **#** for all devices; **#** for a single DECT headset, **#** followed by **1** or **2** for DECT headset/speaker 1 or DECT headset/speaker 2 respectively), or press **▼CID**, **▲DIR**, **▼/RECORD**, or **▲/DELETE** to highlight the desired handset and press **SELECT**. The telephone base shows **Calling HANDSET X** or **Calling all**.



The destination handset(s) rings and shows **Base is calling**, **BASE is calling** or **BASE is calling all**.

2. To answer the intercom call, press **1 LINE**, **2 LINE**, **SPEAKER** (📢), **CELL A** (📶), **CELL B** (📶), any dialing key (**0-9**, **TONEX**), **ANSWER**, or lift the corded handset. Both devices now show **Intercom**.
3. To end the intercom call, press **END**, **OFF/CANCEL**, or put the cordless handset into the charger; or press **END** on the telephone base. Both devices display **Intercom ended**.

i **NOTES:**

- Before the intercom call is answered, you can cancel it by pressing **OFF/CANCEL** on the handset or **END** on the telephone base.
- If the called device is not answered within 100 seconds, or accessing the directory or caller ID log, or is on a call, or is out of range, the initiating device shows **No answer. Try again**.
- To temporarily silence the intercom ringer, press **OFF/CANCEL** or **MUTE/DELETE** on the handset, or press **CANCEL** or **▲/DELETE** on the telephone base.
- You can only use one pair of devices at a time to make intercom calls.

Intercom

Answer an incoming call during an intercom call

When you receive an incoming call on line 1 or line 2 during an intercom call, the two devices on the intercom call hear an alert tone. The screens display **1**, **2**, or **1 2**, and **Incoming call**, and then the caller ID. The telephone base rings and all other handsets ring.

To answer a call on line 1 or line 2 during an intercom call:

Using a cordless handset:

- Press **LINE 1/FLASH**, **LINE 2/FLASH**, or **☎/SPEAKER** to answer the call on line 1 or line 2. The intercom call ends automatically.
- Press **OFF/CANCEL** to end the intercom call without answering the incoming call. The telephone continues to ring.

Using the telephone base:

- Press **1 LINE**, **2 LINE**, **SPEAKER ☎**, or lift the corded handset to answer the call on line 1 or line 2. The intercom call ends automatically.
- Press **BACK** and then **END** to end the intercom call without answering the incoming call. The telephone continues to ring.

When you receive an incoming cell call during an intercom call, the two devices on the intercom call hear an alert tone, and their screens display **A**, **B**, or **A B**, and then the caller ID. The telephone base rings and all other handsets ring.

To answer a cell call during an intercom call:

Using a cordless handset:

- Press **A CELL** or **B CELL** to answer the cell call and the intercom call ends automatically.
- Press **OFF/CANCEL** to end the intercom call without answering the incoming call. The telephone continues to ring.

Using the telephone base:

- Press **CELL A** or **CELL B** to answer the cell call. The intercom call ends automatically.
- Press **BACK** and then **END** to end the intercom call without answering the incoming call. The telephone continues to ring.



NOTES:

- During an intercom on the DECT headset/wireless Speaker, press **ON/OFF** on the DECT headset and **PHONE** on the wireless Speaker to end the intercom session, and then the ringer of the incoming call rings. Press **ON/OFF** on the DECT headset and **PHONE** on the wireless Speaker to answer the incoming call.

Multiple handset use

Call transfer using intercom

Use the intercom feature to transfer an outside call to another system device or the telephone base. You can also share an outside call with another system device or the telephone base.

To transfer an outside call:

Using a cordless handset:

1. When on an outside call, press **OPTION**.
2. Press **SELECT** to choose **Intercom**. The call is automatically put on hold.
 - If you have one handset, the outside call is put on hold and your handset displays **Calling base**. The telephone base rings and displays **HANDSET is calling**.
 - If you have more than one handset, your handset displays **INTERCOM TO:**
 - Press **▼CID** or **▲DIR** to select a destination handset and then press **SELECT**. Your handset displays **Calling HANDSET X** or **Calling BASE**. The destination device rings and displays **HANDSET X is calling**.

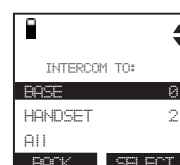

-OR-

- Press **1-9** for **HANDSET 1-9, TONEX** and **0** for **HANDSET 10, TONEX** and **1** for **HANDSET 11** or **TONEX** and **2** for **HANDSET 12**; press **#** for a single DECT headset, **#** followed by **1** or **2** for **DECT headset/speaker 1** or **DECT headset/speaker 2** respectively.

The destination handset rings and displays **HANDSET X is calling**.

3. To answer the intercom call on the other device, press **ANSWER**, **LINE 1/FLASH, LINE 2/FLASH, SPEAKER, A CELL, B CELL** or any dialing key (**0-9** or **TONEX**) on the destination handset, or press **1 LINE, 2 LINE, SPEAKER** on the telephone base. Both handsets and the telephone base show **Intercom** and the outside call is still on hold.
4. From this intercom call, you have the following options:
 - You can transfer the call. Press **OPTION** and then press **SELECT** to select **Transfer** on the calling handset. Your screen shows **Call transferred**. The other handset automatically connects to the outside call.
 - You can let the other device join you on the outside call in a 3-way conversation. Press **OPTION**, and then **▼CID** or **▲DIR** to highlight **Share call**, and press **SELECT**.
 - You can end the intercom call and continue the outside call with your handset. Press **OFF/CANCEL, END, LINE 1/FLASH, LINE 2/FLASH, SPEAKER, A CELL, B CELL** on your handset (the outside call will automatically go off hold and reconnect with your handset).



NOTES:

- If you want to cancel an intercom call and reconnect to the outside call before the destination handset answers, press **OFF/CANCEL** or **END** on the originating handset.
- If the called device is not answered within 100 seconds, or accessing the directory or caller ID log, or is on a call, or is out of range, the initiating device shows **No answer. Try again.** and returns to the outside call.

Multiple handset use

Call transfer using intercom

To transfer an outside call:

Using the telephone base:

1. When on an outside call, press **OPTION**.
2. Press **SELECT** to choose **Intercom**. The call is automatically put on hold.
 - If you have one handset, the outside call is put on hold and your handset displays **Calling HANDSET**. The telephone base rings and displays **BASE is calling**.
 - If you have more than one handset, your base displays **INTERCOM TO:**
 - Press **▼CID**, **▲DIR**, **▼/RECORD**, or **▲/DELETE** to select a destination handset and then press **SELECT**. Your telephone base displays **Calling HANDSET X** or **Calling BASE**. The destination device rings and displays **BASE is calling**.



```
Answering sys
Directory
Caller ID log
Intercom
BACK  SELECT
```

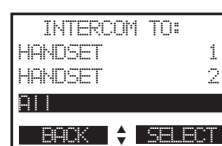

```
INTERCOM TO:
HANDSET 1
HANDSET 2
ALL
BACK  SELECT
```

-OR-

- Press **1-9** for **HANDSET 1-9, TONEX** and **0** for **HANDSET 10, TONEX** and **1** for **HANDSET 11** or **TONEX** and **2** for **HANDSET 12**; press **#** for a single DECT headset, **#** followed by **1** or **2** for **DECT headset/speaker 1** or **DECT headset/speaker 2** respectively.

The destination handset rings and displays **BASE is calling**.

3. To answer the intercom call on any destination handset, press **ANSWER**, **LINE 1/FLASH**, **LINE 2/FLASH**, **◀/SPEAKER**, **ⓐ A CELL**, **ⓑ B CELL** or any dialing key (**0-9** or **TONEX**) on the destination handset. Both handsets and the telephone base show **Intercom** and the outside call is still on hold.
4. From this intercom call, you have the following options:
 - You can transfer the call. Press **OPTION** and then press **SELECT** to select **Transfer** on the telephone base. Your screen shows **Call transferred**. The other handset automatically connects to the outside call.
 - You can let the other device join you on the outside call in a 3-way conversation. Press **OPTION**, and then **▼CID**, **▲DIR**, **▼/RECORD**, or **▲/DELETE** to highlight **Share call**, and press **SELECT**.
 - You can end the intercom call and continue the outside call with your handset. Press **CANCEL**, **END**, **1 LINE**, **2 LINE**, **SPEAKER**, **CELL A** or **CELL B** on the telephone base, or return the corded handset in the telephone base (the outside call will automatically go off hold and reconnect with the telephone base).

i NOTES:

- If you want to cancel an intercom call and reconnect to the outside call before the destination handset answers, press **CANCEL** or **END** on the telephone base.
- If the called device is not answered within 100 seconds, or accessing the directory or caller ID log, or is on a call, or is out of range, the initiating device shows **No answer. Try again.** and returns to the outside call.

Multiple handset use Push-to-talk (PTT)

You can directly broadcast messages from one handset or telephone base to the speakerphone of one or a group of other devices. Press and hold **PUSH TO TALK** on a handset or **PTT** on the telephone base to begin a two-way communication.



PTT

- Only one device can talk at a time. While talking to another device, press and hold **PUSH TO TALK** on the handset or **PTT** on the telephone base.
- You must release **PUSH TO TALK** on the handset or **PTT** on the telephone base, so the other person can respond.
- Only one PTT session can be active at a time.
- While PTT is in use between two devices, other devices cannot use the intercom feature but can access the answering system.
- When you attempt to place a PTT call to another device which is accessing the answering system or on an intercom call or outside call, your device screen shows **Not available at this time**.

 **NOTE:** The PTT function is not available when QUIET mode is on.

Turn PTT on or off

Using a cordless handset:

1. Press **PUSH TO TALK** when the handset is not in use. The **PUSH TO TALK** menu displays.
2. Press **▼CID** or **▲DIR** to highlight **PTT On/Off**, and then press **SELECT**.
3. Press **▼CID** or **▲DIR** to choose **On** or **Off**, and then press **SELECT**.

Using the telephone base:

1. Press **PTT** when the telephone base is not in use. The **PUSH TO TALK** menu displays.
2. Press **▼CID**, **▲DIR**, **▼/RECORD** or **▲/DELETE** to highlight **PTT On/Off**, and then press **SELECT**.
3. Press **▼CID**, **▲DIR**, **▼/RECORD** or **▲/DELETE** to choose **On** or **Off**, and then press **SELECT**.

 **NOTE:** The handset or the telephone base screen displays **PTT** when PTT is turned off.

Push-to-talk (PTT)

PTT call to a single device

Using a cordless handset:

1. There are a few ways to begin a PTT call to a single device. When the handset is not in use:

- If you have one handset, press and hold **PUSH TO TALK**.
- If you have more than one handset:
 - ◆ Press **PUSH TO TALK** on the handset, and then use the dialing keys to enter the destination device number.

-OR-

- ◆ Press **PUSH TO TALK** on the handset. Press **▼CID** or **▲DIR** to highlight the destination device number, and then press **SELECT** or **PUSH TO TALK**.

The handset shows **Connecting to HANDSET X...** (**HANDSET** represents the handset name, **X** represents the destination handset number) or **Connecting to BASE 0...** (**BASE 0** represents the base name) for a few seconds. When the connection is made, both your and the destination device screens display **Press and hold [PTT] to talk**.

2. Press and hold **PUSH TO TALK**. A chirp indicates your microphone is on. Speak towards the device. Your voice is broadcast to the destination device. While you are speaking, your handset shows **PTT To HANDSET X** or **PTT To BASE 0**.
3. Release **PUSH TO TALK** after speaking. Both devices beep once again and the screens show **Press and hold [PTT] to talk**, and then you can press and hold **PUSH TO TALK** to continue speaking or the destination device can respond (see **Answer a PTT call** on page 82).
4. To end the PTT call, press **OFF/CANCEL** or **END**, or place the handset in the charger. The handset shows **Push to talk ended**.

 **NOTE:** After **PUSH TO TALK** is released, the PTT call remains open for a short time. If no one presses **PUSH TO TALK** within 10 seconds, the PTT call ends automatically.

Push-to-talk (PTT)

Using the telephone base:

1. There are a few ways to begin a PTT call to a single handset. When the telephone base is not in use:
 - If you have one handset, press and hold **PTT**.
 - If you have more than one handset:
 - ♦ Press **PTT**, and then use the dialing keys to enter the destination handset number.

-OR-

 - ♦ Press **▼CID**, **▲DIR**, **▼/RECORD** or **▲/DELETE** to highlight the destination handset number, and then press **SELECT** or **PTT**.

The telephone base shows **Connecting to HANDSET X...** (**HANDSET** represents the handset name, **X** represents the destination handset number) for a few seconds. When the connection is made, both the telephone base and destination handset display **Press and hold [PTT] to talk**.

2. Press and hold **PTT**. A chirp indicates your microphone is on. Speak towards the telephone base. Your voice is broadcast to the destination handset. While you are speaking, the telephone base shows **PTT To HANDSET X**.
3. Release **PTT** after speaking. Both devices beep once again and the screens show **Press and hold [PTT] to talk**, and then you can press and hold **PTT** to continue speaking or the destination device can respond (see **Answer a PTT call** on page 82).
4. To end the PTT call, press **CANCEL** or **END**. The telephone base shows **Push to talk Ended** for a few seconds.



NOTE: After **PTT** is released, the PTT call remains open for a short time. If no one presses **PTT** within 10 seconds, the PTT call ends automatically.

Multiple handset use Push-to-talk (PTT)

PTT call to multiple devices

When there are multiple handsets registered to the phone system, PTT supports one-to-group calls. PTT supports a maximum of one-to-four calls when one to five handsets are registered, and a maximum of one-to-three calls when six or more handsets are registered. The first three or four registered handsets will be able to use this feature. Other handsets can only use PTT for one-to-one calls.

To call multiple devices:

Using a cordless handset:

1. You have two ways to call multiple devices. When the handset is not in use:
 - Press and hold **PUSH TO TALK** until the handset shows **Connecting to group...**
 - Press **PUSH TO TALK**. Press **▼CID** or **▲DIR** to choose **Group**. Press **SELECT** or press **PUSH TO TALK** and your handset shows **Connecting to group...**

When the connection is made, both the caller and the destination parties hear a beep. The speakerphones on all other devices automatically activate.

2. You need to press and hold **PUSH TO TALK** when you want to speak. Speak towards the handset. Your voice is broadcast to all devices.
3. Release **PUSH TO TALK** after speaking.
4. Any extension can reply (see **Answer a PTT call** on page 74).



NOTE: After **PUSH TO TALK** is released, the PTT call remains open for a short time. If no one presses **PUSH TO TALK** within ten seconds, the PTT call ends automatically.

Using the telephone base:

1. You have two ways to call multiple handsets. When the telephone base is not in use:
 - Press and hold **PTT** until the screen shows **Connecting to group...**
 - Press **PTT**. Press **▼CID**, **▲DIR**, **▼/RECORD** or **▲/DELETE** to choose **Group**. Press **SELECT** or **PTT** and the telephone base shows **Connecting to group...**

When the connection is made, both the caller and the destination parties hear a beep. The speakerphones on all other devices automatically activate.

2. You need to press and hold **PTT** when you want to speak. Speak towards the telephone base. Your voice is broadcast to all devices.
3. Release **PTT** after speaking.
4. Any extension can reply (see **Answer a PTT call** on page 82).



NOTE: After **PTT** is released, the PTT call remains open for a short time. If no one presses **PTT** within ten seconds, the PTT call ends automatically.

Multiple handset use
Push-to-talk (PTT)

Answer a PTT call

You can respond to a PTT call as described below.

Using a handset or the telephone base:

1. When your device receives a PTT call, it beeps and shows **Press and hold [PTT] to talk**.
2. When the other party is speaking, your speakerphone light is on, and your device shows:
 - **PTT From HANDSET X To devices: X** (the first **X** represents the initiating handset number, and the second **X** represents your handset number; a maximum of four handset numbers appear).
 - OR-
 - **PTT From BASE 0 To devices: X** (the **X** represents your handset number; a maximum of four handset numbers appear).
3. When your speakerphone light is off (the screen shows **Press and hold [PTT] to talk**), press and hold **PUSH TO TALK** on your handset or **PTT** on your telephone base. You will hear a chirp. Speak towards the device.
 - While you are speaking, your device shows **PTT To Handset: X** (**X** represents the handset numbers of one or more destination handsets; a maximum of four handset numbers appear) or **PTT To devices: X** (**X** represents the handset numbers of one or more destination handsets; a maximum of four handset numbers appear).
 - Your voice is broadcast to all destination devices.

After speaking, release **PUSH TO TALK** on your handset or **PTT** on your telephone base. Your device will beep. After the beep, if your speakerphone light is off, you can press and hold **PUSH TO TALK** on your handset or **PTT** on your telephone base to continue speaking, or the destination device can respond.

Push-to-talk (PTT)

Change a one-to-one PTT call to an intercom call

You can convert a one-to-one PTT session to an intercom call.

Using a cordless handset or the telephone base:

1. When your device shows **Press and hold [PTT] to talk**, press **INTCOM**. The screen shows **Switch to Intercom?**
2. Press **SELECT**. Your device displays **Calling BASE** or **Calling HANDSET X**. The destination device briefly shows **Push to talk Ended** and then **HANDSET X is calling** or **BASE is calling**. The destination device rings.
3. Press **LINE 1/FLASH**, **LINE 2/FLASH** or any dialing keys (**0-9**, or **TONE X**) on the destination handset, or press **1 LINE**, **2 LINE** or any dialing keys (**0-9**, or **TONE X**) on the telephone base to answer the intercom call. Both devices now show **Intercom**.
4. To end the intercom call, press **OFF/CANCEL** or **END** on your cordless handset, or place the cordless handset in the charger; or press **END** on the telephone base. Both screens show **Intercom ended**.

Answer an incoming call during a PTT call

When you receive an outside call during PTT, there is an alert tone.

Using a cordless handset or the telephone base:

- During a one-to-one PTT, press **LINE 1/FLASH**, **LINE 2/FLASH**, **A CELL** or **B CELL** on the initiating or destination handset, or press **1 LINE**, **2 LINE**, **CELL A** or **CELL B** on the telephone base. The PTT call ends automatically and the outside call is answered.
- During a one-to-group PTT call, press **LINE 1/FLASH**, **LINE 2/FLASH**, **A CELL** or **B CELL** on the initiating handset, or press **LINE 1**, **LINE 2**, **CELL A** or **CELL B** on the telephone base. The PTT call ends automatically and the outside call is answered.
- During a one-to-group PTT call, press **LINE 1/FLASH**, **LINE 2/FLASH**, **A CELL** or **B CELL** on any one of the destination handsets, or press **1 LINE**, **2 LINE**, **CELL A** or **CELL B** on the telephone base. That device answers the outside call. The PTT call continues for the rest of the PTT participants.
- To leave the PTT call without answering the incoming call, press **OFF/CANCEL** on your handset or **CANCEL** on your telephone base. The telephone continues to ring.

Multiple handset use

Push-to-talk (PTT)

Make an outgoing call during PTT call

Using a cordless handset or the telephone base:

- During a one-to-one PTT call, press **LINE 1/FLASH** or **LINE 2/FLASH** on your handset or **1 LINE** or **2 LINE** on the telephone base to get a dial tone. The PTT call ends automatically.
- During a one-to-group PTT call, press **LINE 1/FLASH** or **LINE 2/FLASH** on the initiating handset or **1 LINE** or **2 LINE** on the telephone base. The PTT call ends automatically and you get a dial tone.
- During a one-to-group PTT call, press **LINE 1/FLASH** or **LINE 2/FLASH** on any one of the destination handsets or **1 LINE** or **2 LINE** on the telephone base. That device gets a dial tone. The PTT call continues for the rest of the PTT participants.

End or leave a PTT call

Using a cordless handset or the telephone base:

For one-to-one PTT calls, both initiating and destination devices can end the PTT call. For PTT calls to multiple devices, the initiating device can end the PTT call. If any one of the destination devices leaves the PTT call, the call continues until all participants or the initiator hangs up.

Press **OFF/CANCEL** or **END** on the handset, or press **CANCEL** or **END** on the telephone base. The screens show **Push to talk Ended**.

-OR-

Place the cordless handset in the charger, and then the handset returns to idle mode. The telephone base screen shows **Push to talk Ended**.



NOTE: After **PUSH TO TALK** on the handset or **PTT** on the telephone base is released, the PTT call remains open for a short time. If no one presses **PUSH TO TALK** on the handset or **PTT** on the telephone base within ten seconds, the PTT call ends automatically.

Directory

About the directory

The home directory stores up to 200 entries with up to 30 digits for each phone number and 15 characters for each name. Each of the downloaded directories stores up to 1,500 entries with up to 30 digits for each phone number and 15 characters for each name.

- Directory entries are stored at the telephone base and shared by all system handsets. Any changes made on one device apply to all.
- Only one device can review the directory at a time. If another device tries to enter the directory, its screen shows **Not available at this time**.
- When there are no records in the directory, the screen shows **Directory empty**.
- When the directory is full and you try to save an entry, the screen shows **Directory full**.
- When you try to save a number already stored in the directory, the screen shows **Number already saved**.

All of the instructions on pages 78-86 for the directories apply to the home directory and all downloaded directories. Creating a new entry on pages 78-81 only applies to the home directory.

You cannot create new entries in your downloaded directories from the **TL86103** handset. Entries must be downloaded from your cell phone (see **Download directory** on pages 28-29).

Create directory entries

Create a new entry in the home directory

Using a cordless handset:

1. Press **MENU** on the handset in idle mode to enter the main menu.
2. Press **▼CID** or **▲DIR** to highlight **Directory**, and then press **SELECT**.
3. Press **OPTION** to choose **Home**.
4. Press **SELECT** to choose **Add contact**. The screen displays **ENTER NUMBER**.
5. Use the dialing keys to enter a telephone number.
 - Press **▼CID** or **▲DIR** to move the cursor to the left or right.
 - Press **MUTE/DELETE** to erase a digit.
 - Press and hold **MUTE/DELETE** to erase all digits.
 - Press and hold **REDIAL/PAUSE** to enter a dialing pause (a **p** appears).

-OR-

Copy a number from the redial list. Press **REDIAL/PAUSE** and then **▼CID** or **▲DIR**, or **REDIAL/PAUSE** repeatedly to locate the number. Press **INSERT** to copy the displayed number.

6. Press **NEXT**.
7. Press **▼CID** or **▲DIR** to highlight one of the following types:
 - Home
 - Cell
 - Work
 - Other
8. Press **NEXT**. The screen displays **ENTER NAME**.
9. Use the dialing keys (see page 88) to enter a name (up to 15 characters).
 - Press **▼CID** or **▲DIR** to move the cursor to the left or right.
 - Press **0** to add a space.
 - Press **MUTE/DELETE** to erase a character.
 - Press and hold **MUTE/DELETE** to erase all characters.
 - Press **a>A** to change the next letter to upper or lower case.
10. Press **SAVE** to confirm and the screen shows **Saved**. You hear a confirmation tone.

Directory

Create directory entries

Using the telephone base:

1. Press **MENU** on the telephone base in idle mode to enter the main menu.
2. Press **▼CID**, **▲DIR**, **▼/RECORD** or **▲/DELETE** to highlight **Directory**, and then press **SELECT**.
3. Press **OPTION** to choose **Home**.
4. Press **SELECT** to choose **Add contact**. The screen displays **ENTER NUMBER**.
5. Use the dialing keys to enter a telephone number.
 - Press **▼CID** or **◀/REPEAT** to move the cursor to the left. Press **▲DIR** or **▶/SKIP** to move the cursor to the right.
 - Press **▲/DELETE** to erase a digit.
 - Press and hold **▲/DELETE** to erase all digits.
 - Press and hold **REDIAL/PAUSE** to enter a dialing pause (a **p** appears).

-OR-

Copy a number from the redial list. Press **REDIAL/PAUSE** and then **▼CID** or **▲DIR**, or **REDIAL/PAUSE** repeatedly to locate the number. Press **INSERT** to copy the displayed number.

6. Press **NEXT**.
7. Press **▼CID**, **▲DIR**, **▼/RECORD** or **▲/DELETE** to highlight one of the following types:
 - Home
 - Cell
 - Work
 - Other
8. Press **NEXT**. The screen displays **ENTER NAME**.
9. Use the dialing keys (see page 88) to enter a name (up to 15 characters).
 - Press **▼CID** or **◀/REPEAT** to move the cursor to the left. Press **▲DIR** or **▶/SKIP** to move the cursor to the right.
 - Press **0** to add a space.
 - Press **▲/DELETE** to erase a character.
 - Press and hold **▲/DELETE** to erase all characters.
 - Press **a>A** to change the next letter to upper or lower case.
10. Press **SAVE** to confirm and the screen shows **Saved**. You hear a confirmation tone.

Directory
Create directory entries

Dialing keys

Dialing keys	Characters by number of key presses										
	1	2	3	4	5	6	7	8	9	10	11
1	1	.	-	'	()	*	#	&	/	,
2	A	B	C	a	b	c	2				
3	D	E	F	d	e	f	3				
4	G	H	I	g	h	i	4				
5	J	K	L	j	k	l	5				
6	M	N	O	m	n	o	6				
7	P	Q	R	S	p	q	r	s	7		
8	T	U	V	t	u	v	8				
9	W	X	Y	Z	w	x	y	z	9		
0	space	0									
*											
#											



NOTE: When entering a name in the directory, the first letter of each word is automatically capitalized.

Create directory entries

Add a predialed telephone number to the directory

You can save a predialed telephone number to the directory.

Using a cordless handset:

1. Enter the telephone number when in idle mode, and then press **SAVE** to move on to edit the number and then press **NEXT**.
2. Press **▼CID** or **▲DIR** to highlight one of the following types:
 - Home
 - Cell
 - Work
 - Other
3. Press **NEXT**. The screen displays **ENTER NAME**.
4. Use the dialing keys to edit the name.
 - Press **▼CID** or **▲DIR** to move the cursor to the left or right.
 - Press **MUTE/DELETE** to erase a character.
 - Press and hold **MUTE/DELETE** to erase all characters.
5. Press **SAVE** to save the entry. There is a confirmation tone and the screen shows **Saved**.

Using the telephone base:

1. Enter the telephone number when in idle mode, and then press **SAVE** to move on to edit the number and then press **NEXT**.
2. Press **▼CID**, **▲DIR**, **▼/RECORD** or **▲/DELETE** to highlight one of the following types:
 - Home
 - Cell
 - Work
 - Other
3. Press **NEXT**. The screen displays **ENTER NAME**.
4. Use the dialing keys to edit the name.
 - Press **▼CID** or **◀/REPEAT** to move the cursor to the left. Press **▲DIR** or **▶/SKIP** to move the cursor to the right.
 - Press **▲/DELETE** to erase a character.
 - Press and hold **▲/DELETE** to erase all characters.
5. Press **SAVE** to save the entry. There is a confirmation tone and the screen shows **Saved**.

Directory

Review the directory

Review directory entries

Using a cordless handset:

1. Press **▲DIR** when in idle mode.
2. Press **▼CID** or **▲DIR** to highlight a directory, and then press **REVIEW**.
3. Press **▼CID** or **▲DIR** to browse.

-OR-

1. Press **MENU** when in idle mode.
2. Press **▼CID** or **▲DIR** to highlight **Directory**, and then press **SELECT**.
3. Press **▼CID** or **▲DIR** to highlight a directory, and then press **REVIEW**.
4. Press **▼CID** or **▲DIR** to browse.

-OR-

1. Press **OPTION** while on a call.
2. Press **▼CID** or **▲DIR** to highlight **Directory**, and then press **SELECT**.
3. Press **▼CID** or **▲DIR** to highlight a directory, and then press **REVIEW**.
4. Press **▼CID** or **▲DIR** to browse.

Directory

Review the directory

Using the telephone base:

1. Press **▲DIR** when in idle mode.
2. Press **▼CID, ▲DIR, ▼/RECORD** or **▲/DELETE** to highlight a directory, and then press **REVIEW**.
3. Press **▼CID, ▲DIR, ▼/RECORD** or **▲/DELETE** to browse.

-OR-

1. Press **MENU** when in idle mode.
2. Press **▼CID, ▲DIR, ▼/RECORD** or **▲/DELETE** to highlight **Directory**, and then press **SELECT**.
3. Press **▼CID, ▲DIR, ▼/RECORD** or **▲/DELETE** to highlight a directory, and then press **REVIEW**.
4. Press **▼CID, ▲DIR, ▼/RECORD** or **▲/DELETE** to browse.

-OR-

1. Press **OPTION** while on a call.
2. Press **▼CID, ▲DIR, ▼/RECORD** or **▲/DELETE** to highlight **Directory**, and then press **SELECT**.
3. Press **▼CID, ▲DIR, ▼/RECORD** or **▲/DELETE** to highlight a directory, and then press **REVIEW**.
4. Press **▼CID, ▲DIR, ▼/RECORD** or **▲/DELETE** to browse.



NOTES:

- When the desired entry displays, press **#** (pound key) on the handset or telephone base repeatedly to show different dialing options.
- **Directory empty** appears if there are no directory entries.

Search the directory

3-character alphabetical search

You can use the enhanced 3-character search to find your contacts quickly and efficiently.

Using a cordless handset or the telephone base:

1. Follow the steps in **Review directory entries** on the previous page to enter the directory.
2. When an entry appears, use the dialing keys to enter the letters associated with the name (see page 88). You can enter up to 3 letters for the search. The letters will show at the top left hand corner of the screen. After you have entered one to three letters, the system starts searching in the directory. If there is no name matching the letter(s) entered, the next closest match in alphabetical order appears. If necessary, press **▼CID** or **▲DIR** on the cordless handset, or **▼CID**, **▲DIR**, **▼/RECORD** or **▲/DELETE** on the telephone base to browse.



NOTE: The cursor automatically moves to the next position 2 seconds after you enter a letter. If you do not enter another letter in the coming 2 seconds, the system starts searching in the directory.

Dial, edit or delete a directory entry

Dial a directory entry

You can dial a directory entry on any line.

To dial a directory entry:

1. Search for the desired entry in the directory (see **Review directory entries** and **3-character alphabetical search** on pages 90-92).
2. When the desired entry appears, press **#** (pound key) repeatedly on the handset or telephone base to show different dialing options.
3. When the displayed number is in the correct format, press **LINE 1/FLASH**, **LINE 2/FLASH** or **◀)/SPEAKER** on the handset, or **1 LINE, 2 LINE, SPEAKER** on the telephone base, or lift the corded handset to use line 1 or line 2. Press **☎CELL A** or **☎CELL B** on the handset or **CELL A** or **CELL B** on the telephone base to use the cell line.

888-883-2445
1-888-883-2445
883-2445
1-883-2445

Edit a directory entry

You can edit any directory entry. However, be aware that if you download a directory from a cell phone again, the directory is erased and replaced with the current cell phone directory. If you have edited the downloaded entries on the **TL86103**, those changes are lost. To avoid losing changes made to the downloaded directory, we suggest that you edit numbers in your cell phone, and then download the directory.

Using a cordless handset:

1. Search for the desired entry in the directory (see **Review directory entries** and **3-character alphabetical search** on pages 90-92).
2. When a directory entry displays, press **EDIT**. The screen shows **EDIT NUMBER** along with the phone number to be edited.
3. Use the dialing keys to edit the number:
 - Press **▼CID** or **▲DIR** to move the cursor to the left or right.
 - Press **MUTE/DELETE** to erase a digit.
 - Press and hold **MUTE/DELETE** to erase all digits.
 - Press and hold **REDIAL/PAUSE** to add a dialing pause (a **p** appears).
4. Press **NEXT**.
5. Press **▼CID** or **▲DIR** to highlight one of the following types.
 - Home
 - Cell
 - Work
 - Other
6. Press **NEXT**. The screen displays **EDIT NAME**.

Directory

Dial, edit or delete a directory entry

7. Use the dialing keys to edit the name.
 - Press **▼CID** or **▲DIR** to move the cursor to the left or right.
 - Press **MUTE/DELETE** to erase a character.
 - Press and hold **MUTE/DELETE** to erase all characters.
8. Press **SAVE** to save the entry. There is a confirmation tone and the screen shows **Saved**.

Using the telephone base:

1. Search for the desired entry in the directory (see **Review directory entries** and **3-character alphabetical search** on pages 90-92).
2. When a directory entry displays, press **EDIT**. The screen shows **EDIT NUMBER** along with the phone number to be edited.
3. Use the dialing keys to edit the number:
 - Press **▼CID** or **◀/REPEAT** to move the cursor to the left. Press **▲DIR** or **▶/SKIP** to move the cursor to the right.
 - Press **▲/DELETE** to erase a digit.
 - Press and hold **▲/DELETE** to erase all digits.
 - Press and hold **REDIAL/PAUSE** to add a dialing pause (a **p** appears).
4. Press **NEXT**.
5. Press **▼CID**, **▲DIR**, **▼/RECORD** or **▲/DELETE** to highlight one of the following types.
 - Home
 - Cell
 - Work
 - Other
6. Press **NEXT**. The screen displays **EDIT NAME**.
7. Use the dialing keys to edit the name.
 - Press **▼CID** or **◀/REPEAT** to move the cursor to the left. Press **▲DIR** or **▶/SKIP** to move the cursor to the right.
 - Press **▲/DELETE** to erase a character.
 - Press and hold **▲/DELETE** to erase all characters.
8. Press **SAVE** to save the entry. There is a confirmation tone and the screen shows **Saved**.

Directory

Dial, edit or delete a directory entry

Edit the type of a directory entry

If you only want to edit the type of a directory entry:

1. Search for the desired entry in the directory (see **Review directory entries** and **3-character alphabetical search** on pages 90-92).
2. When a directory entry displays, press **LABEL** on a handset or **TONEX** on the telephone base.
3. Enter the corresponding shortcut keys shown in the below table.

Type	Press
Home	1
Cell	2
Work	3
Other	4

-OR-

Press **CLEAR** to erase the assigned label.

Delete a directory entry

Using a cordless handset or the telephone base:

1. Search for the desired entry in the directory (see **Review directory entries** and **3-character alphabetical search** on pages 90-92).
2. When the desired entry appears, press **MUTE/DELETE** on the handset, or **▲/DELETE** or **DELETE** on the telephone base. The screen displays **Delete contact?** and the name of the entry. Press **YES** to confirm.
3. The screen displays **Contact deleted** and then the next alphabetical entry in the directory. You hear a confirmation tone.



NOTE: Once a directory entry is deleted, it cannot be retrieved.

Directory

Dial, edit or delete a directory entry

Remove a downloaded directory

Using a cordless handset:

1. Search for the desired downloaded directory in the directory menu (see **Review directory entries** and **3-character alphabetical search** on pages 82-83).
2. When the desired downloaded directory is chosen, press **OPTION**, and then press **▼CID** or **▲DIR** to highlight **Remove dir**.
3. Press **SELECT**. The screen displays **Directory Cell Phone A will be erased**.
4. Press **YES** to confirm. The screen displays **Erasing directory...** You hear a confirmation tone.

Using the telephone base:

1. Search for the desired downloaded directory in the directory menu (see **Review directory entries** and **3-character alphabetical search** on pages 82-83).
2. When the desired downloaded directory is chosen, press **OPTION**, and then press **▼CID**, **▲DIR**, **▼/RECORD** or **▲/DELETE** to highlight **Remove dir**.
3. Press **SELECT**. The screen displays **Directory Cell Phone A will be erased**.
4. Press **YES** to confirm. You hear a confirmation tone.

Caller ID

About caller ID

This product supports caller ID services offered by most telephone service providers. Caller ID allows you to see the name, number, date and time of calls. The available caller ID information will appear after the first or second ring.

Information about caller ID with call waiting

Caller ID with call waiting lets you see the name and telephone number of the caller before answering the call, even while on another call.

It may be necessary to change your telephone service to use this feature. Contact your telephone service provider if:

- You have both caller ID and call waiting, but as separate services (you may need to combine these services).
- You have only caller ID service, or only call waiting service.
- You don't subscribe to caller ID or call waiting services.

There are fees for caller ID services. In addition, services may not be available in all areas.

This product can provide information only if both you and the caller are in areas offering caller ID service and if both telephone service providers use compatible equipment. The time and date, along with the call information, are from the telephone service provider.

Caller ID information may not be available for every incoming call. Callers may intentionally block their names and/or telephone numbers. You can only view a maximum of 15 digits of every caller ID log entry.



NOTE: You can use this product with regular caller ID service, or you can use this product's other features without subscribing to caller ID or combined caller ID with call waiting service.

Caller ID Caller ID log

How the caller ID log works

The telephone stores caller ID information about the last 50 incoming calls in the telephone base. Entries are stored in reverse chronological order. The phone deletes the oldest entry when the log is full to make room for new calls. This information is common to the telephone base and all handsets, so changes made using any handset or the telephone base are reflected in all other devices. If you answer a call before the information appears on the screen, it does not show in the caller ID log.



NOTE: Each entry may have up to 24 digits for the phone number and 15 characters for the name.

Missed (new) call indicator

When a handset or the telephone base is in idle mode and has new or missed calls, its screen shows **XX Missed calls**. If there are more than 99 missed calls, the handset screen will show **XXX Missed calls**.

All new and missed entries are counted as missed calls. Each time you review a new caller ID log entry (indicated by **NEW** on the screen), the number of missed calls decreases by one.

If you do not want to review the missed calls one by one, but still want to keep them in the caller ID log, you can press and hold **OFF/CANCEL** on the handset for four seconds when the handset is idle, or press and hold **CANCEL** on the telephone base for four seconds when the telephone base is idle. You will hear a confirmation tone. All the entries in the caller ID log become old (reviewed already), and the missed calls message goes away.

Memory match

If the incoming telephone number matches the last 7 digits of a telephone number in your directory, the name that appears on the screen matches the corresponding name in your directory.

For example, if Christine Smith calls, her name appears as **Chris** if this is how you entered it into your directory.



NOTE: The number shown in the caller ID log will be in the format sent by the telephone service provider. The telephone service provider usually delivers ten-digit phone numbers (area code plus telephone number). If the telephone number of the caller does not match a number in your directory, the name will appear as it is delivered by the telephone service provider.

Caller ID
 Caller ID operation

Review the caller ID log

Review the caller ID log to find out who called, to return the call, or to copy the caller's name and number into your directory. **Caller ID log empty** appears if there are no records in the caller ID log.

Using a cordless handset or the telephone base:

1. When a handset or the telephone base is in idle mode, press **▼CID** on the handset or on the telephone base to review the caller ID log in reverse chronological order starting with the most recent call.

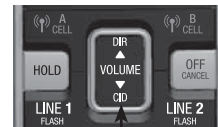

CID

-OR-

Review the caller ID log by pressing **MENU**. Press **▼CID** or **▲DIR** on the handset or **▼CID**, **▲DIR**, **▼/RECORD** or **▲/DELETE** on the telephone base to highlight **Caller ID log**, and then press **SELECT** twice to select **Review**.



CALLER ID

2. Press **▼CID** or **▲DIR** on the handset or **▼CID**, **▲DIR**, **▼/RECORD** or **▲/DELETE** on the telephone base to scroll through the list.



NOTE: Only one handset or the telephone base can review the caller ID log at a time. If another device tries to enter the directory or caller ID log, it shows **Not available at this time**.

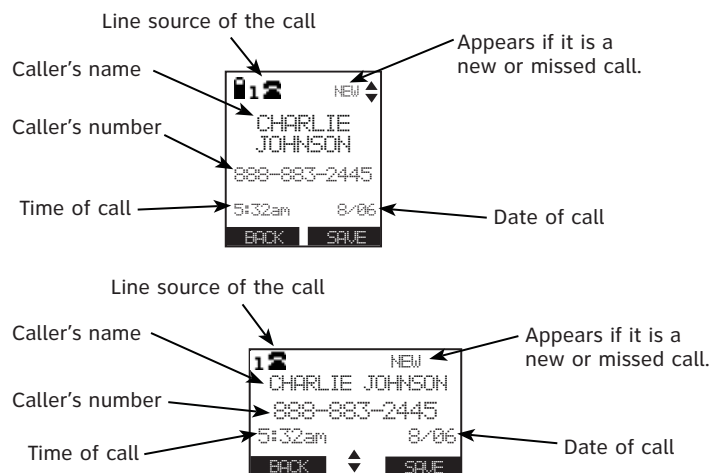

Caller ID operation

View dialing options

Although the incoming caller ID log entries have ten digits (the area code plus the seven-digit number), in some areas, you may need to dial only the 7 digits, 1 plus the seven digits, or 1 plus the area code plus the seven digits. You can change and store the number of digits that you dial in the caller ID log.

While reviewing the caller ID log, press **#** (pound key) repeatedly to show different dialing options for local and long distance numbers before dialing or saving the telephone number in the directory.

Press **1** repeatedly if you need to add or remove 1 in front of the telephone number before dialing or saving it in the directory.

When the number is in the correct format for dialing.

Press **LINE 1/FLASH, LINE 2/FLASH** or **◀/SPEAKER** on a cordless handset, or press **1 LINE, 2 LINE**, or **SPEAKER▶** on the on the telephone base, or lift the corded handset to call the number using line 1 or line 2.

-OR-

Press **CELL A** or **CELL B** on a cordless handset or **CELL A** or **CELL B** on the telephone base to call the number using the cell line.

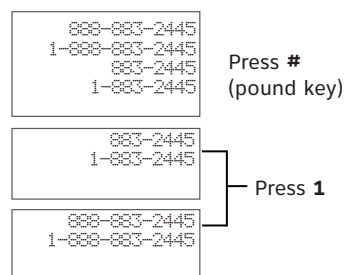

Dial a caller ID log entry

Using a cordless handset or the telephone base:

1. When in the caller ID log, press **▼CID** or **▲DIR** on the handset, or **▼CID, ▲DIR, ▼/RECORD** or **▲/DELETE**, on the telephone base to browse.
2. Press **LINE 1/FLASH, LINE 2/FLASH** or **◀/SPEAKER** on the handset, or **1 LINE, 2 LINE** or **SPEAKER▶** on the telephone base, or lift the corded handset to dial the displayed entry using line 1 or line 2.

-OR-

Press **CELL A** or **CELL B** on the handset or **CELL A** or **CELL B** on the telephone base to dial the display entry using the cell line.

Caller ID operation

Save a caller ID log entry to the directory

Caller ID log entries can only be saved to the **Home** directory.

Using a cordless handset:

1. Select a desired entry in the caller ID log (see **Review the caller ID log** on page 99).
2. When the desired entry appears, press **#** (pound key) repeatedly to show different dialing options.
3. When the number is in correct format, press **SAVE**. The screen displays **EDIT NUMBER**.
4. Use the dialing keys to edit the number.
 - Press **▼CID** or **▲DIR** to move the cursor to the left or right.
 - Press **MUTE/DELETE** to backspace and erase a digit.
 - Press and hold **MUTE/DELETE** to erase the entire entry.
 - Press and hold **REDIAL/PAUSE** to insert a dialing pause (a **p** appears).
5. Press **NEXT**.
6. Press **▼CID** or **▲DIR** to highlight one of the following types:
 - Home
 - Cell
 - Work
 - Other
7. Press **NEXT**. The handset displays **EDIT NAME**.
8. Use the dialing keys (page 80) to edit the name.
 - Press **▼CID** or **▲DIR** to move the cursor to the left or right.
 - Press **MUTE/DELETE** to erase a character.
 - Press and hold **MUTE/DELETE** to erase all characters.
 - Press **#** (pound key) to move the last word to the front. For example, Johnson Charlie becomes **Charlie Johnson** when you press **#** (pound key).
9. Press **SAVE** to confirm. The screen shows **Saved**.

Caller ID operation

Using the telephone base:

1. Select a desired entry in the caller ID log (see **Review the caller ID log** on page 99).
2. When the desired entry appears, press **#** (pound key) repeatedly to show different dialing options.
3. When the number is in correct format, press **SAVE**. The telephone base displays **EDIT NUMBER**.
4. Use the dialing keys to edit the number.
 - Press **▼CID** or **◀/REPEAT** to move the cursor to the left. Press **▲DIR** or **▶/SKIP** to move the cursor to the right.
 - Press **▲/DELETE** to backspace and erase a digit.
 - Press and hold **▲/DELETE** to erase the entire entry.
 - Press and hold **REDIAL/PAUSE** to insert a dialing pause (a **p** appears).
5. Press **NEXT**.
6. Press **▼CID**, **▲DIR**, **▼/RECORD** or **▲/DELETE** to highlight one of the following types:
 - Home
 - Cell
 - Work
 - Other
7. Press **NEXT**. The telephone base displays **EDIT NAME**.
8. Use the dialing keys (page 80) to edit the name.
 - Press **▼CID** or **◀/REPEAT** to move the cursor to the left. Press **▲DIR** or **▶/SKIP** to move the cursor to the right.
 - Press **▲/DELETE** to erase a character.
 - Press and hold **▲/DELETE** to erase all characters.
 - Press **#** (pound key) to move the last word to the front. For example, Johnson Charlie becomes **Charlie Johnson** when you press **#** (pound key).
9. Press **SAVE** to confirm. The telephone base shows **Saved**.



NOTES:

- If the caller's name you received from the telephone service provider is all in capital letters, the first letter of every word remains a capital letter, while other letters become lowercase. However, the next letter after the prefix "Mac", "Mc", "D", "C" or "O", is kept as a capital letter. For example, the "D" in "MacDonald" is kept as a capital letter. Another exception is that "VAN DER" will be changed to "Van der".
- If the telephone number from the caller ID information has already been saved in the directory under a different name, the new name will overwrite the old one.

Caller ID operation

Delete caller ID log entries

To delete an entry:

Using a cordless handset:

Press **MUTE/DELETE** on the handset.

Using the telephone base:

Press **▲/DELETE** or **DELETE** the telephone base to delete the shown entry.

To delete all entries:

Using a cordless handset:

1. Press **MENU** when in idle mode.
2. Press **▼CID** or **▲DIR** to highlight **Caller ID log**, and then press **SELECT**.
3. Press **▼CID** or **▲DIR** to highlight **Delete all calls**, and then press **SELECT**.
4. When the screen shows **Delete all calls?**, press **YES** to confirm. There is a confirmation tone and the screen returns to the previous menu.

Using the telephone base:

1. Press **MENU** when in idle mode.
2. Press **▼CID, ▲DIR, ▼/RECORD** or **▲/DELETE** to highlight **Caller ID log**, and then press **SELECT**.
3. Press **▼CID, ▲DIR, ▼/RECORD** or **▲/DELETE** to highlight **Delete all calls**, and then press **SELECT**.
4. When the screen shows **Delete all calls?**, press **YES** to confirm. There is a confirmation tone and the screen returns to the previous menu.

Caller ID

Reasons for missing caller ID information

There are occasions when other information or no information shows for various reasons:

On-screen message	Reason
PRIVATE NUMBER	The caller prefers not to show the phone number.
PRIVATE NAME	The caller prefers not to show the name.
PRIVATE CALLER	The caller prefers not to show the phone number and name.
UNKNOWN NUMBER	Your telephone service provider cannot determine the caller's number.
UNKNOWN NAME	Your telephone service provider cannot determine the caller's name.
UNKNOWN CALLER	Your telephone service provider cannot determine the caller's name and telephone number. Calls from other countries may also generate this message.

Answering system settings

Use the answering system menu of the telephone base to set up the announcement message, turn the answering system or message alert tone on or off, activate call screening, or change the number of rings, remote access code or message recording time. If you turn off the answering system and you change any setting in the answering system setup menu, the answering system automatically turns on again.

Announcement

Your outgoing announcement plays when calls are answered by the answering system.

The telephone has a default outgoing announcement, *"Hello, please leave a message after the tone."* You can use this default announcement, or record your own.

You can record an announcement up to 90 seconds. The system does not record any announcement shorter than two seconds.

To play a new outgoing announcement:

Using the telephone base:

1. When the telephone base is in idle mode, press **MENU** to enter the main menu.
2. Press **▼CID**, **▲DIR**, **▼/RECORD** or **▲/DELETE** to highlight **Answering system**, and then press **SELECT**.
3. Press **▼CID**, **▲DIR**, **▼/RECORD** or **▲/DELETE** to highlight **Mailbox 1** or **Mailbox 2**, and then press **SELECT**.
4. Press **SELECT** again to select **Announcement**.
5. Press **SELECT** to select **Play annc**, and then press **SELECT**.

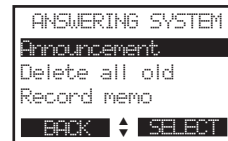

Answering system

Answering system settings

To record a new outgoing announcement:

Using the telephone base:

1. When the telephone base is in idle mode, press **MENU** to enter the main menu.
2. Press **▼CID, ▲DIR, ▼/RECORD** or **▲/DELETE** to highlight **Answering system**, and then press **SELECT**.
3. Press **▼CID, ▲DIR, ▼/RECORD** or **▲/DELETE** to highlight **Mailbox 1** or **Mailbox 2**, and then press **SELECT**.
4. Press **SELECT** again to select **Announcement**.
5. Press **SELECT** to select **Record annnc**. The system announces, "Record after the tone. Press **STOP** when you are done."
6. Speak towards the telephone base to record your announcement. Press **STOP** to end recording. Your recorded announcement plays.



-OR-

1. When the telephone base is in idle mode, press **▼/RECORD**.
2. Press **▼CID, ▲DIR, ▼/RECORD** or **▲/DELETE** to highlight **Announcement**, and then press **SELECT**.
3. Press **▼CID, ▲DIR, ▼/RECORD** or **▲/DELETE** to highlight **Mailbox 1** or **Mailbox 2**, and then press **SELECT**. The system announces, "Record after the tone. Press **STOP** when you are done."
4. Speak towards the telephone base to record your announcement. Press **STOP** to end recording. Your recorded announcement plays.

To listen to the recorded announcement again, scroll to **Play annnc** and press **SELECT**.

Answering system settings

To delete or reset your outgoing announcement:

Using the telephone base:

1. When the telephone base is in idle mode, press **MENU** to enter the main menu.
2. Press **▼CID, ▲DIR, ▼/RECORD** or **▲/DELETE** to highlight **Answering system**, and then press **SELECT**.
3. Press **▼CID, ▲DIR, ▼/RECORD** or **▲/DELETE** to highlight **Mailbox 1** or **Mailbox 2**, and then press **SELECT**.
4. Press **SELECT** again to select **Announcement**.
5. Press **▼CID, ▲DIR, ▼/RECORD** or **▲/DELETE** to highlight **Play annc**, and then press **SELECT**.
6. While the announcement is playing, press **▲/DELETE** to delete the announcement. The system announces "Announcement deleted" and the screen shows **Ann. Reset**.

-OR-

1. When the telephone base is in idle mode, press **MENU** to enter the main menu.
2. Press **▼CID, ▲DIR, ▼/RECORD** or **▲/DELETE** to highlight **Answering system**, and then press **SELECT**.
3. Press **▼CID, ▲DIR, ▼/RECORD** or **▲/DELETE** to highlight **Mailbox 1** or **Mailbox 2**, and then press **SELECT**.
4. Press **SELECT** again to select **Announcement**.
5. Press **▼CID, ▲DIR, ▼/RECORD** or **▲/DELETE** to highlight **Reset annc**, and then press **SELECT**. The screen shows **Reset to default annc?**
6. Press **YES** to confirm. The system announces "Announcement deleted" and the screen shows **Announcement reset to default**.

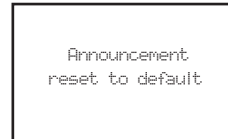
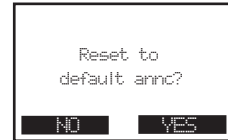

When your announcement is deleted, the system answers calls with the default announcement described on page 105. You cannot delete the default announcement.

Answering system settings

Answer on/off

Unless you change it, the answering system is on and ready to record messages. You can turn the answering system off, but if you do so, the answering system does not answer calls and record incoming messages.

To turn the answering system on or off:

Using the telephone base:

Press **⓪/LINE 1 ANS ON/OFF** or **⓪/LINE 2 ANS ON/OFF** to turn the corresponding answering system on or off. If the answering system is turned on, it announces, "Calls will be answered." If the answering system is turned off, it announces, "Calls will not be answered."

-OR-

1. When the telephone base is in idle mode, press **MENU** to enter the main menu.
2. Press **▼CID, ▲DIR, ▼/RECORD** or **▲/DELETE** to highlight **Answering system**, and then press **SELECT**.
3. Press **▼CID, ▲DIR, ▼/RECORD** or **▲/DELETE** to highlight **Mailbox 1** or **Mailbox 2**, and then press **SELECT**.
4. Press **▼CID, ▲DIR, ▼/RECORD** or **▲/DELETE** to highlight **Answer ON/OFF**, and then press **SELECT**.
5. Press **▼CID, ▲DIR, ▼/RECORD** or **▲/DELETE** to highlight **On** or **Off**, and then press **SELECT** to save the setting. You hear a confirmation tone.

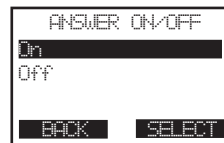
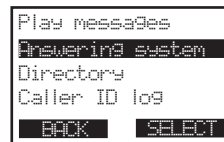

NOTE: If the answering system is off and there is an incoming call, the system answers after ten rings and announces, "Please enter your remote access code." For more information about remote access, see page 122.

Answering system settings

Call screening

Use this feature to choose whether incoming messages can be heard over the speaker when they are being recorded. If you turn call screening on, you hear the incoming message. While monitoring an incoming message, you can answer the call by pressing **LINE 1/FLASH**, **LINE 2/FLASH** or **Ⓜ/SPEAKER** on the handset, or pressing **1 LINE**, **2 LINE** or **SPEAKER Ⓜ** on the telephone base, or lift the corded handset to answer the incoming call.

To change the setting:

Using the telephone base:

1. When the telephone base is in idle mode, press **MENU** to enter the main menu.
2. Press **▼CID**, **▲DIR**, **▼/RECORD** or **▲/DELETE** to highlight **Answering system**, and then press **SELECT**.
3. Press **▼CID**, **▲DIR**, **▼/RECORD** or **▲/DELETE** to highlight **Mailbox 1** or **Mailbox 2**, and then press **SELECT**.
4. Press **▼CID**, **▲DIR**, **▼/RECORD** or **▲/DELETE** to highlight **Ans system setup**, and then press **SELECT**.
5. Press **SELECT** to select **Call screening**.
6. Press **▼CID**, **▲DIR**, **▼/RECORD** or **▲/DELETE** to choose **On** or **Off**.
7. Press **SELECT** to save the setting. You hear a confirmation tone.

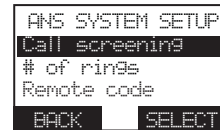

NOTE: For more information on call screening, see page 116.

Answering system settings

Number of rings

You can set the answering system to answer an incoming call after two, three, four, five or six rings. You can also select toll saver. If toll saver is selected, the answering system answers a call after two rings when you have new messages, and after four rings when there are no new messages. This feature allows you to check for new messages and avoid paying long distance charges when calling from out of your local area. By default, the answering system answers an incoming call after four rings.

To set the number of rings:

Using the telephone base:

1. When the telephone base is in idle mode, press **MENU** to enter the main menu.
2. Press **▼CID**, **▲DIR**, **▼/RECORD** or **▲/DELETE** to highlight **Answering system**, and then press **SELECT**.
3. Press **▼CID**, **▲DIR**, **▼/RECORD** or **▲/DELETE** to highlight **Mailbox 1** or **Mailbox 2**, and then press **SELECT**.
4. Press **▼CID**, **▲DIR**, **▼/RECORD** or **▲/DELETE** to highlight **Ans system setup**, and then press **SELECT**.
5. Press **▼CID**, **▲DIR**, **▼/RECORD** or **▲/DELETE** to highlight **# of rings**, and then press **SELECT**.
6. Press **▼CID**, **▲DIR**, **▼/RECORD** or **▲/DELETE** to choose among **2, 3, 4, 5, 6** or **Toll saver**.
7. Press **SELECT** to save the setting. You hear a confirmation tone.

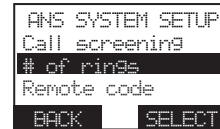

NOTE: If you set the number of rings for the answering system as 2 or 3 rings, the caller ID announce feature may not have enough time to announce the caller's full information.

Answering system settings

Remote access code

To access your answering system remotely from any touch-tone phone, you need to enter a two-digit number (00-99). By default, the remote access code is **19**.

Using the telephone base:

1. When the telephone base is in idle mode, press **MENU** to enter the main menu.
2. Press **▼CID**, **▲DIR**, **▼/RECORD** or **▲/DELETE** to highlight **Answering system**, and then press **SELECT**.
3. Press **▼CID**, **▲DIR**, **▼/RECORD** or **▲/DELETE** to highlight **Mailbox 1** or **Mailbox 2**, and then press **SELECT**.
4. Press **▼CID**, **▲DIR**, **▼/RECORD** or **▲/DELETE** to highlight **Ans system setup**, and then press **SELECT**.
5. Press **▼CID**, **▲DIR**, **▼/RECORD** or **▲/DELETE** to highlight **Remote code**, and then press **SELECT**.
6. Use the dialing keys to enter a two-digit number. Press **▲/DELETE** to backspace and delete a digit.
7. Press **SAVE** to save the setting. You hear a confirmation tone.

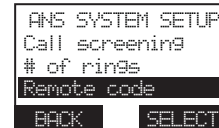

Answering system settings

Message alert tone

When the message alert tone is set to **On**, and there is at least one new message, the telephone base beeps every ten seconds. Unless you change it, the message alert tone is set to off.

There is no audible alert at the handset.

To change the setting:

Using the telephone base:

1. When the telephone base is in idle mode, press **MENU** to enter the main menu.
2. Press **▼CID, ▲DIR, ▼/RECORD** or **▲/DELETE** to highlight **Answering system**, and then press **SELECT**.
3. Press **▼CID, ▲DIR, ▼/RECORD** or **▲/DELETE** to highlight **Mailbox 1** or **Mailbox 2**, and then press **SELECT**.
4. Press **▼CID, ▲DIR, ▼/RECORD** or **▲/DELETE** to highlight **Ans system setup**, and then press **SELECT**.
5. Press **▼CID, ▲DIR, ▼/RECORD** or **▲/DELETE** to highlight **Msg alert tone**, and then press **SELECT**.
6. Press **▼CID, ▲DIR, ▼/RECORD** or **▲/DELETE** to choose **On** or **Off**.
7. Press **SELECT** to save the setting. You hear a confirmation tone.

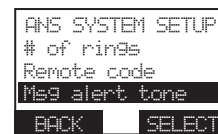

NOTES:

- The message alert tone beeps only if all the conditions below are met:
 - Answering system is on.
 - Message alert tone setting is on.
 - There are new messages.
- To temporarily turn off the message alert tone, see page 115.

Answering system settings

Message recording time

You can set the recording time allowed for incoming messages. The message length is three minutes by default.

To change the setting:

Using the telephone base:

1. When the telephone base is in idle mode, press **MENU** to enter the main menu.
2. Press **▼CID**, **▲DIR**, **▼/RECORD** or **▲/DELETE** to highlight **Answering system**, and then press **SELECT**.
3. Press **▼CID**, **▲DIR**, **▼/RECORD** or **▲/DELETE** to highlight **Mailbox 1** or **Mailbox 2**, and then press **SELECT**.
4. Press **▼CID**, **▲DIR**, **▼/RECORD** or **▲/DELETE** to highlight **Ans system setup**, and then press **SELECT**.
5. Press **▼CID**, **▲DIR**, **▼/RECORD** or **▲/DELETE** to highlight **Recording time**, and then press **SELECT**.
6. Press **▼CID**, **▲DIR**, **▼/RECORD** or **▲/DELETE** to choose **3 minutes**, **2 minutes** or **1 minute**, and then press **SELECT** to save the setting. You hear a confirmation tone.

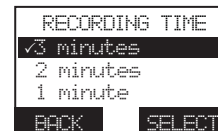
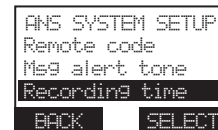

About the answering system

Answering system and voicemail indicators

Your telephone has separate indicators for two different types of voice messages: those recorded on its built-in answering system and those recorded in your service provider's voicemail (fees may apply). Your telephone's built-in answering system messages and voicemail messages are separate. Each alerts you to new messages differently.

- If **00** and **L1) XX New msgs** and/or **L2) XX New msgs** display on the telephone base and handsets, there are new messages in the built-in answering system. To listen to messages recorded on your digital answering system, press **▶/■/LINE 1 MAIL BOX** or **▶/■/LINE 2 MAIL BOX** on the telephone base. To listen to messages with a handset, see **To listen to messages on a cordless handset** on page 117.
- If **✉¹**, **✉₂**, or **✉¹₂** and **L1) Voicemail** and/or **L2) Voicemail** display on telephone base and handsets, your telephone service provider is indicating that it has new voicemail for you. To listen to your voicemail, you typically dial an access number provided by your telephone service provider, followed by a security code or PIN.

Some service providers bundle or combine multiple services like voicemail and call waiting, so you may not be aware that you have voicemail. To check what services you have and how to access them, contact your telephone service provider.

To use your voicemail service rather than your answering system, turn off your answering system. To use your answering system rather than your voicemail service, contact your telephone service provider to deactivate your voicemail service.

Using the answering system and voicemail together

You can also use your telephone answering system and voicemail together by setting your built-in answering system to answer before voicemail answers as described below. To learn how to program your voicemail settings, contact your telephone service provider. Then, if you are on a call, or if the answering system is busy recording a message and you receive another call, the second caller can leave a voicemail message.

Set your answering system to answer calls at least two rings earlier than your voicemail is set to answer. For example, if your voicemail answers after six rings, set your answering system to answer after four rings. Some voicemail providers may program the delay before answering calls in seconds instead of rings. In this case, allow six seconds per ring when determining the appropriate setting.

About the answering system

Message capacity

The answering system can record and store up to 99 messages. Each message can be up to 3 minutes in length depending on the message length set.

The total storage capacity for the announcement, messages and memos is approximately 14 minutes. The actual recording time depends on individual message characteristics. Messages remain available for replay until you delete them.

When there are new messages (including memos) on the answering system, the number of messages stored shows in the message counter.

If the answering system has less than three minutes of recording time left, it announces, *"Less than three minutes to record,"* before message playback at the handset or the telephone base. **L1) Rec mem low** and/or **L2) Rec mem low** displays on the device screen in idle mode. When you turn on the answering system at the telephone base, it announces, *"Calls will be answered. Less than three minutes to record."*

If the memory is full, the answering system announces, *"Memory is full,"* before message playback. The device screen displays **L1) Rec mem full** and/or **L2) Rec mem full** in idle mode. Once the memory is full, you cannot turn the answering system back on if it has been turned off, nor can you record new messages until old ones have been deleted. **Memory full** displays if you want to turn on the answering system on the handset but there is no memory.

Voice prompts

The system provides voice prompts to guide you through the setup procedures at the telephone base, message playback, remote access and recording outgoing announcements.

Temporarily turning off the message alert tone

If the message alert tone is turned on, the telephone base beeps every ten seconds when there are new messages. Pressing any telephone base key temporarily silences the message alert tone.

The message alert tone resumes when you receive another message.

About the answering system

Call screening

To screen a call at the telephone base:

If the answering system and call screening are on (see **Call screening** on page 109), the announcement and the incoming message broadcast at the telephone base when a call is answered by the answering system.

Options while a message is being recorded:

- Press **▼/VOLUME/▲** on the telephone base to adjust the call screening volume.
- Press **▶/■/LINE 1 MAIL BOX**, **▶/■/LINE 2 MAIL BOX** or **SILENCE** to temporarily silence the call screening.
- Press **▶/■/LINE 1 MAIL BOX**, **▶/■/LINE 2 MAIL BOX** or **SCREEN** to temporarily turn on the call screening if call screening is set to off.
- Press **1 LINE**, **2 LINE**, **SPEAKER** **◀▶**, or lift the corded handset to answer the call.

To screen a call at the handset:

If the answering system is on and your answering system is recording a message, press **SCREEN** to screen the call on your handset and the screen displays the caller ID information. If you do not subscribe to caller ID service, the handset shows **Incoming call**.

Options while a message is being recorded:

- Press **▼CID/VOLUME** or **▲DIR/VOLUME** on the handset to adjust the call screening volume.
- Press **OFF/CANCEL** or **SILENCE** to temporarily silence the call screening.
- Press **SCREEN** to temporarily turn on the call screening if call screening is set to off.
- Press **◀▶/SPEAKER** to broadcast the announcement and the incoming message through the speakerphone. Press again to turn off the speakerphone.

Call intercept

When a caller is leaving a message on your answering system, you can stop recording and talk to the caller by pressing the corresponding line button **LINE 1/FLASH** or **LINE 2/FLASH**, or **◀▶/SPEAKER** on the handset. You can also press the corresponding line button **1 LINE** or **2 LINE**, or **SPEAKER** **◀▶** on the telephone base; or lift the corded handset.

Answering system

Message playback

If you have both new and old messages, you can play either new or old messages. The caller ID information displays on the screens when you play messages and you can call back the caller.

When playback begins, the handset and telephone base screens display the message status, caller ID information, and time and date of the message recorded. You hear the total number of messages followed by the day and time of the message. After the last message, the telephone announces, "End of messages." and the screen displays **End of messages**.

To listen to messages at the telephone base:

1. Press **▶/■/LINE 1 MAIL BOX** or **▶/■/LINE 2 MAIL BOX** on the telephone base to listen to the messages.
 - If there are new and old messages, news messages will play automatically.
 - If there are only new or only old messages, they will play automatically.

When the handset is playing a message, its screen shows **[2]-Call info** and the caller's name or number. If the caller's information is unavailable, the handset shows **No caller info**.

The system announces the number of messages, and then begins playback. The message sequence is shown on the telephone base. If there are no recorded messages, the telephone base shows **No messages** and you hear, "You have no message."

To listen to messages on a cordless handset:

1. When the handset is in idle mode, press **MENU** to enter the main menu.
2. Press **SELECT** to select **Play messages**.
3. Press **▼CID** or **▲DIR** to highlight **Mailbox 1** or **Mailbox 2**, and then press **SELECT**.
 - If there are new and old messages, press **▼CID** or **▲DIR** to select **Play new msgs** or **Play old msgs**, and then press **SELECT**.
 - If there are only new or only old messages, they will play automatically.





The system announces the number of messages, and then begins playback. The message sequence is shown on the handset. If there are no recorded messages, the handset shows **No messages** and you hear, "You have no messages."

Message playback

Options during playback

When a message is playing, you can adjust the playback volume, skip, repeat, pause or delete the message.

When messages are playing on the telephone base:

- Press **▼/VOLUME/▲** to adjust the speaker volume.
- Press **▶/SKIP** or **SKIP** to skip to the next message.
- Press **◀/REPEAT** or **REPEAT** to repeat the message currently playing. Press **◀/REPEAT** or **REPEAT** twice to listen to the previous message.
- Press **▲/DELETE** to delete the current message. The system advances to the next message.
- Press **2** to pause the playback and show the caller ID information.
 - Press **1 LINE, 2 LINE, SPEAKER**  or **CALL** to use line 1 or line 2, or press **Cell A**  or **Cell B**  to use the cell line to call back the caller. If necessary, press **QUIET #** (pound key) or **1** to show different dialing options.
 - Press **CANCEL** or **BACK** to restart the playback. If you do not call back within 10 seconds, message playback restarts.
- Press **1 LINE, 2 LINE, Cell A**  or **Cell B**  to pause the message playback. The telephone base screen displays **Call back?** with the caller ID information. If the dialing format used is not correct, press **QUIET #** (pound key) or **1** to show different dialing options. Press **CALL** to call back the caller, or **BACK** to restart the message playback. If the dialing format used is not correct, and then use the option above to choose the correct format before calling back the caller.
- Press **▶/■/LINE 1 MAIL BOX**, **▶/■/LINE 2 MAIL BOX** or **CANCEL** to stop the playback.

Answering system

Message playback

When messages are playing on a cordless handset:

- Press **⏮/SPEAKER** to play the messages through the handset earpiece. Press **⏮/SPEAKER** again to return to playing messages through the speakerphone.
- Press **▼CID/VOLUME** or **▲DIR/VOLUME** to adjust the speakerphone volume.
- Press **SKIP** to skip to the next message.
- Press **REPEAT** to repeat the message currently playing. Press **REPEAT** twice to listen to the previous message.
- Press **DELETE** to delete the current message.
- Press **2** to pause the playback and show the caller ID information.
 - Press **LINE 1/FLASH, LINE 2/FLASH, ⏮/SPEAKER** or **CALL** to use line 1 or line 2, or press **ⓂA Cell** or **ⓂB Cell** to use the cell line to call back the caller. If necessary, press **#** (pound key) or **1** to show different dialing options.
 - Press **OFF/CANCEL** or **BACK** to restart the playback. If you do not call back within 10 seconds, message playback restarts.
- Press **LINE 1/FLASH, LINE 2/FLASH, ⓂA Cell** or **ⓂB Cell** to pause the message playback. The handset displays **Call back?** with the caller ID information. If the dialing format used is not correct, press **QUIET #** (pound key) or **1** to show different dialing options. Press **CALL** to call back the caller, or **BACK** to restart the message playback. If the dialing format used is not correct, and then use the option above to choose the correct format before calling back the caller.
- Press **OFF/CANCEL** to stop the playback.

Answering system

Message playback

Delete all old messages

You can only delete old (reviewed) messages. You cannot delete new messages until you review them. You cannot retrieve deleted messages.

To delete all old messages on the telephone base:

1. When the telephone is idle, press **▲/DELETE**.
2. Press **▼CID, ▲DIR, ▼/RECORD** or **▲/DELETE** to highlight **Mailbox 1** or **Mailbox 2**, and then press **SELECT**. The screen shows **Delete all old messages?**
3. Press **YES** to confirm. The screen displays **Deleting** then **All old msgs deleted!** You hear a confirmation tone.

-OR-

1. Press **MENU** when in idle mode to enter the main menu.
2. Press **▼CID, ▲DIR, ▼/RECORD** or **▲/DELETE** to highlight **Answering system**, and then press **SELECT**.
3. Press **▼CID, ▲DIR, ▼/RECORD** or **▲/DELETE** to highlight **Mailbox 1** or **Mailbox 2**, and then press **SELECT**.
4. Press **▼CID, ▲DIR, ▼/RECORD** or **▲/DELETE** to highlight **Delete all old**, and then press **SELECT**. The screen shows **Delete all old messages?**
5. Press **YES** to confirm. The screen displays **Deleting** then **All old msgs deleted!** You hear a confirmation tone.

Recording and playing memos

Memos are your own recorded messages used as reminders for yourself or others using the same answering system. You can record your own memos using the telephone base. Play and delete them the same way as incoming messages.

Record a memo

Using the telephone base:

1. When the telephone base is in idle mode, press **MENU** to enter the main menu.
2. Press **▲/DELETE** to highlight **Answering system**, and then press **SELECT**.
3. Press **▼CID**, **▲DIR**, **▼/RECORD** or **▲/DELETE** to highlight **Mailbox 1** or **Mailbox 2**, and then press **SELECT**.
4. Press **▼CID**, **▲DIR**, **▼/RECORD** or **▲/DELETE** to highlight **Record memo**, and then press **SELECT**. The system announces, "Record after the tone. Press **STOP** when you are done."
5. Speak towards the handset to record a memo.
6. Press **STOP** to stop recording. The systems announces, "Recorded." and the returns to the previous menu.

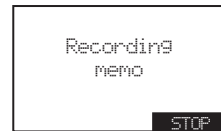

-OR-

1. When the telephone base is in idle mode, press **▼/RECORD**.
2. Press **▼CID**, **▲DIR**, **▼/RECORD** or **▲/DELETE** to highlight **Memo**, and then press **SELECT**.
3. Press **▼CID**, **▲DIR**, **▼/RECORD** or **▲/DELETE** to highlight **Mailbox 1** or **Mailbox 2**, and then press **SELECT**.The system announces, "Record after the tone. Press **STOP** when you are done."
4. Speak towards the handset to record a memo.
5. Press **STOP** to stop recording. The systems announces, "Recorded." and the returns to the previous menu.

NOTES:

- The system announces "Memory is full," if you attempt to record a memo when the memory is full.
- Each memo can be up to four minutes in length.
- Memos shorter than two seconds are not recorded.

Playback a memo

Play memos the same way as messages. See **Message playback** on pages page 117-120.

Answering system

Remote access

You can reach your answering system remotely by dialing your home telephone number from any touch-tone telephone.

To remotely access the answering system

1. Dial your telephone number from any touch-tone telephone.
2. When the system plays your announcement, enter the two-digit remote access code (**19** is the default code, see page 111 to change it).
 - The system automatically announces the number of new or old messages (if any), and then begins to play them.
3. You can also enter the following remote commands.

Remote commands

1	Press to listen to all messages.
2	Press to listen to new messages only.
3	Press to delete the current message (during playback).
33	Press twice to delete all old messages.
4	Press to repeat the current message (during playback).
44	Press twice to listen to the previous message.
5	Press to stop.
*5	Press to listen to a list of remote commands.
6	Press to skip to the next message (during playback).
*7	Press to record a new announcement.
8	Press to hang up the call.
0	Press to turn the answering system on or off.

4. Hang up or press **8** to end the call.

Answering system

Remote access

Cut out and carry the remote access wallet card at the back of this user's manual for quick reference.



NOTES:

- If you do not press any keys after you enter the remote access code, all new messages play. If there are no new messages, all old messages play.
- Once the new messages have played, the telephone announces the help menu options. If you do not press any key within 20 seconds, the remote access call automatically disconnects.
- When the answering system is turned off, the telephone answers after 10 rings, and announces, *"Please enter your remote access code."*
- When the memory is full, the answering system answers incoming calls after 10 rings and announces, *"Memory is full. Enter the remote access code."*

Adding and registering cordless handsets/headsets/ wireless speakers

Your telephone can support up to 12 DECT 6.0 cordless handsets (AT&T model **TL86003**, sold separately), or up to ten cordless handsets and two DECT cordless headsets and wireless speakers (sold separately). Visit **www.telephones.att.com/headsets** for a list of compatible DECT 6.0 cordless handsets. Each new handset, headset or wireless speaker must be registered to the telephone base before use. You must register each handset, headset or wireless speaker separately.

To register a cordless headset to this telephone system, please refer to the user's manual of the cordless headset for more details. To register a cordless handset, see below.

The handsets provided within your product box are already registered as **HANDSET 1** and so forth. Additional handsets are assigned numbers in the sequential order they are registered (up to **HANDSET 12**).

Register a cordless handset to your telephone base

Using the telephone base:

1. Before you begin registration, make sure the handset is out of the charger and shows **To register, see user manual**.
2. Press **MENU** on the telephone base in idle mode.
3. Press **▼CID**, **▲DIR**, **▼/RECORD** or **▲/DELETE** to highlight **Settings**, and then press **SELECT**.
4. Press **▼CID**, **▲DIR**, **▼/RECORD** or **▲/DELETE** to highlight **Registration**, and then press **SELECT**.
5. The telephone base shows **Registering... Please wait**.
6. Press **#** on the cordless handset for registration, and the handset shows **Registering... Please wait**. It takes about 90 seconds to complete the registration process. Both the telephone base and cordless handset display **HANDSET X Registered** (X represents the registered handset number), and beep when registration completes.



If registration fails, the system will automatically try to register again. If registration fails after the third try, the handset displays **Registration failed**, and then **To register, see user manual**. This may take up five minutes to occur. Please start again from Step 1 above.

i NOTE: You cannot register a handset if any other system handset is in use.

Deregister cordless handsets

You may need to deregister your handsets if:

- You have 12 registered handsets and need to replace a handset.
-OR-
- You wish to reassign the designated handset number of your registered handsets.

You must first deregister ALL handsets, and then register each handset you wish to use again, one at a time.

Please read carefully through all the instructions on this page before beginning the deregistration process.

Deregister all cordless handsets from the telephone base

1. Make sure that all handsets are out of the charger before you begin deregistration.
2. Press and hold **HOLD** on the telephone base for about 10 seconds. The telephone base shows **Deregister all devices?** Release **HOLD**.
3. Quickly press **HOLD** again or press **YES** within 5 seconds. If the telephone base returns to the idle screen, start again with Step 1 above.
4. The telephone base shows **Deregistered all devices** and then returns to the idle screen. All system handsets show **To register, see user manual** and you hear a confirmation tone when the deregistration completes. The deregistration process takes about 10 seconds to complete.



















After deregistering, register each handset again individually following the registrations on the previous page.

i **NOTES:**

- If the deregistration process fails, you may need to reset the system and try again. To reset, unplug the power from the telephone base and plug it back in.
- You cannot deregister the handsets if any other system handset is in use.















Appendix
Alert tones and lights

Handset screen icons

	<p>Line 1 or Line 2 - On steadily when line 1 and/or line 2 is in use or there is an incoming call on line 1 and/or line 2.</p>
	<p>CELL A or Cell B- On steadily when Cell A line and/or Cell B line is in use or there is an incoming call on Cell A line and/or Cell B line.</p>
	<p>Bluetooth connected devices - There are Bluetooth connected devices on the active devices list.</p>
	<p>Bluetooth disconnected devices - There are Bluetooth disconnected devices on the active devices list.</p>
	<p>Wireless Bluetooth headset - On steadily when a wireless Bluetooth headset is in use on line 1 or line 2.</p>
	<p>Battery status - Battery is charging (animated display).</p>
	<p>Battery status - The battery icon flashes when the battery is low and needs charging.</p>
	<p>Speakerphone - The speakerphone is in use.</p>
	<p>New voicemail - You have new voicemail on line 1 and/or line 2 from your telephone service provider.</p>
	<p>Message - New message in the built-in answering system.</p>
	<p>ECO mode - Activates automatically to reduce power consumption when the handset is within range from the telephone base.</p>
	<p>New caller ID log - New and missed calls.</p>
	<p>MUTE - The handset microphone is off.</p>
	<p>Ringer off - The handset ringer is off.</p>
	<p>NO INCOMING PTT - The incoming PTT function on the handset is off.</p>
	<p>PC CALL ringer off - The handset ringer for PC call is off.</p>

Appendix
Alert tones and lights

Telephone base screen icons

	<p>LINE 1 or LINE 2 - On steadily when line 1 and/or line 2 is in use or there is an incoming call on line 1 and/or line 2.</p>
	<p>CELL A or Cell B- On steadily when Cell A line and/or Cell B line is in use or there is an incoming call on Cell A line and/or Cell B line.</p>
	<p>Bluetooth connected devices - There are Bluetooth connected devices on the active devices list.</p>
	<p>Bluetooth disconnected devices - There are Bluetooth disconnected devices on the active devices list.</p>
	<p>Wireless Bluetooth headset - On steadily when a wireless Bluetooth headset is in use on line 1 or line 2.</p>
	<p>New voicemail - You have new voicemail on line 1 and/or line 2 from your telephone service provider.</p>
	<p>New answering system message - New message in the answering system.</p>
	<p>New caller ID log - Missed and new calls.</p>
	<p>Mute - Microphone is muted.</p>
	<p>Directory Search Bar - 3-Character Search</p>
	<p>Number of missed call - Missed call indication for Home and Cell lines</p>
	<p>Ringer off - The telephone base ringer is off.</p>
	<p>NO INCOMING PTT - The incoming PTT function on the telephone base is off.</p>
	<p>PC CALL ringer off - The telephone base ringer for PC call is off.</p>

Appendix

Alert tones and lights

Handset alert tones

One short beep	Tone of each key press, if key tone is turned on.
One long beep	Indication to begin recording a message, memo or announcement.
Two short beeps	You are pressing ▼CID/VOLUME OR ▲DIR/VOLUME on a cordless handset when the volume is already at its highest or lowest setting. -OR- Call waiting tone. -OR- Error tone. -OR- Registration slots are full.
Confirmation tone (three rising tones)	The system has completed the command successfully.
Four beeps	The other party has ended your intercom call. -OR- The handset has gone out of range from the base during a call.
Four short beeps	Low battery warning.
Four rising tones	Your Android cell phone has received mobile notifications.

Appendix

Alert tones and lights

Telephone base alert tones

One short beep	Tone of each key press, if key tone is turned on.
One long beep	Indication to begin recording a message, memo or announcement. Indicates the start of message recording during call screening or the end of a message playback session.
Two short beeps	You are pressing ▼/ VOLUME /▲ on the telephone base when the volume is already at its highest or lowest setting. -OR- Call waiting tone. -OR- Error tone. -OR- Registration slots are full.
Confirmation tone (three rising tones)	The system has completed the command successfully.
Four beeps	The other party has ended your intercom call.
Four short beeps	Registration failure tone.
Four rising tones	Your Android cell phone has received mobile notifications.
Beeps every ten seconds	Message alert.

Appendix
Alert tones and lights

Lights

SPEAKER
On when the speakerphone is in use.

LINE 1 ANS ON/OFF / LINE 2 ANS ON/OFF
On when the answering system is on.

LINE 1 MAIL BOX / LINE 2 MAIL BOX

- On when the answering system is playing recorded messages.
- Flash when there are new messages.

CELL A / CELL B / HEADSET lights

- On when the telephone base is paired and connected with a Bluetooth device.
- Flash alternately while pairing a Bluetooth device.
- Flash quickly when there is an incoming cell call.

1 LINE / 2 LINE

- On when line 1 or line 2 is in use.
- Flash quickly when there is an incoming call on line 1 or line 2.
- Flash slowly when the call on line 1 or line 2 is on hold.

CHARGE light
On when the handset is charging in the charger.

High contrast lighted display

Keypad

SPEAKER
On when the speakerphone is on.

Appendix
Display screen messages

Screen messages

Answering sys in On during quiet mode	QUIET mode is turned on. The answering system is automatically turned on.
BASE is calling	The telephone base is calling.
BASE is calling all	The telephone base is calling all devices (for intercom calls).
Bluetooth system busy	You are trying to make a cell call or access the Bluetooth menu when the Bluetooth link is already being used.
Call transferred	You have transferred an outside call to another device.
Caller ID log empty	There are no entries in the caller ID log.
Calling BASE 0	The handset is calling the telephone base (for intercom calls).
Calling HANDSET X	The handset or telephone base is calling another handset (for intercom calls). The telephone base is transferring an outside call to a handset.
CELL A	Cell A line is on a call.
CELL B	Cell B line is on a call.
CL) A: <Application>	The cell phone that you paired with this telephone received a mobile notification.
CL) A In use	Cell A line is being used
CL) A low batt	Message received from Alerts manager that your cell phone's battery is low.
CL) A On hold	A call on Cell A line has been put on hold.
CL) A Ringer off	The ringer of Cell A line is turned off.
CL) B: <Application>	The cell device that you paired with this telephone received a mobile notification.
CL) B In use	Cell B line is being used
CL) B low batt	Message received from Alerts manager that your cell device's battery is low.
CL) B On hold	A call on Cell B line has been put on hold.
CL) B Ringer off	The ringer of Cell B line is turned off.
CL) Ringers off	The ringers of both cell lines are turned off.
CL) A&B In use	Both cell lines are being used.
CL) A&B On hold	Calls on both cell lines have been put on hold.
CL) Downloading	The system is downloading a directory from a cell phone.
CL) Downloading...	The system is downloading a directory from a cell phone.
Connection failed	A Bluetooth device failed to establish a connection with your telephone system.

Appendix
Display screen messages

Screen messages

Contact deleted	A directory entry is deleted.
Directory empty	There are no directory entries.
Directory full	The directory is full. You cannot save any new entries unless you delete some current entries.
Ended	You have just ended a call.
HANDSET X is calling	Another system handset is calling.
HANDSET X is calling all	The handset is calling all devices.
Intercom	The device is on an intercom call.
Intercom ended	The intercom call has just ended.
L1>Ans sys off	The answering system of line 1 is turned off.
L1>In use	Line 1 is being used.
L1>No line	There is no telephone line connection to line 1.
L1>On hold	A call on line 1 has been put on hold.
L1>Rec mem full	The system recording time for line 1 is full.
L1>Rec mem low	The system recording time for line 1 is low.
L1>Ringer off	The ringer of line 1 is turned off.
L1>Voicemail	A new voicemail is detected in line 1.
L1>XX New msgs	Displays on telephone base screen when you have new messages in the answering system of line 1.
L2>Ans sys off	The answering system of line 2 is turned off.
L2>In use	Line 2 is being used.
L2>No line	There is no telephone line connection to line 1.
L2>On hold	A call on line 2 has been put on hold.
L2>Rec mem full	The system recording time for line 2 is full.
L2>Rec mem low	The system recording time for line 2 is low.
L2>Ringer off	The ringer of line 2 is turned off.
L2>Voicemail	A new voicemail is detected in line 2.
L2>XX New msgs	Displays on telephone base screen when you have new messages in the answering system of line 2.
Line 1	Line 1 is on a call.
Line 2	Line 2 is on a call.
Low battery	The battery is low. You should charge the battery.

Appendix
Display screen messages

Screen messages

Microphone ON	Mute is off so the other party can hear your voice.
Muted	The microphone is off. The other party cannot hear you.
No answer. Try again	The device(s) you are trying to transfer a call to is out of range, off hook, or has no power.
No battery	The handset in the charger has no battery installed.
No Bluetooth device is ready for connection.	There is no Bluetooth device paired to the telephone system when you press CELL A/CELL B/HEADSET  on the telephone base or handset.
No caller info	The caller information is unavailable.
No entries found. Download from SIM only?	There are no entries found when you download a cell phone directory from the cell memory.
No entries found. Download from Phone only?	There are no entries found when you download a cell phone directory from your SIM card. There are no entries found in either the cell or SIM card when you download a cell phone directory from both memories.
No messages	There are no messages in the answering system.
No signal. Call ended.	The phone lost connection with the telephone base or did not have a strong enough signal and the phone call ended.
Not available at this time	Someone else is already using the directory or caller ID log. When a handset tries to access the answering system or Bluetooth menu during battery backup mode.
Number already saved	The telephone number you have entered is already in the directory.
Out of range OR no Power at base	The telephone base has lost power, or the handset is out of range.
** Paging **	The cordless handset is paged by the telephone base.
Paging all devices	The telephone base is paging all devices.
PC CALL	PC line is on a call.
PC CALL On hold	A call on PC line has been put on hold.
Place in charger	The battery is very low. The handset should be charged.
PTT From HANDSET X To devices: X	One handset has started a PTT session to another handset and telephone base.

Appendix
 Display screen messages

Screen messages

PTT To HANDSET X	You have started the PTT process with a handset.
PTT To BASE 0	You have started the PTT process with the telephone base.
Push to talk Ended	The PTT session is ended.
Quiet mode is off	QUIET mode is turned off.
Registering... Please wait	The handset is registering to the telephone base.
Registration slots are full	The telephone base has the maximum of 12 handsets registered to it.
Registration failed	The handset registration is not successful.
Ringer muted	The ringer is off temporarily while the device is ringing.
Saved	An entry has been successfully saved in the directory.
To register HS, see manual.	Screen display before handset registration.
Unable to call. Try again	You try to join a call when there are already four handsets on that call. You try to make an outside call when another device is transferring a call with the intercom feature.
XX Missed calls	There are missed calls in the caller ID log.
XXX Missed calls	There are more than 99 missed calls in the caller ID log.

Appendix
Troubleshooting

If you have difficulty with your phone, please try the suggestions below. For Customer Service, visit our website at **www.telephones.att.com** or call **1 (800) 222-3111**. In Canada, dial **1 (866) 288-4268**.

I cannot pair my cell phone to the telephone base.

- Make sure you have cellular coverage.
- Make sure your cell phone is compatible with your telephone system. Check the Bluetooth compatibility list at **www.telephones.att.com/bluetooth**.
- Make sure the Bluetooth function of your cell phone is turned on. See the user's manual of your cell phone for more information.
- Make sure that you set your cell phone to search for devices.
- If the telephone systems in your cell phone device history list, delete it and try pairing again.
- Carefully follow the pairing instructions on pages 21-31 and make sure that your cell phone is not connected to any other Bluetooth device.
- Turn off your cell phone, and then turn it on again.
- Reset the telephone base. Unplug the unit's electrical power. Wait for approximately 15 seconds, and then plug it back in. Repeat the above suggestions.

I cannot pair my headset to the telephone base.

- Make sure that your Bluetooth headset is in discoverable mode when pairing with the telephone base. See the user's manual of your headset for more information on how to set your headset to discoverable mode.
- Make sure your headset is compatible with your telephone system. Check the Bluetooth compatibility list at **www.telephones.att.com/bluetooth**.
- Carefully follow the pairing instructions on pages 23-24 and make sure that your headset is not connected to any other Bluetooth device.
- Reset the telephone base. Unplug the unit's electrical power. Wait for approximately 15 seconds, and then plug it back in. Repeat the above suggestions.

Appendix
Troubleshooting

I cannot connect my cell phone with the telephone base.

- Make sure that the Bluetooth function of your cell phone is turned on. See the user's manual of your cell phone for more information.
- Make sure that your Bluetooth cell phone is not connected to any other Bluetooth device.
- Turn off your cell phone, and then turn it on again.
- Make sure that your cell phone is on the active devices list.
- For some cell phones, you must authorize the **TL86103** device in your cell phone's Bluetooth feature. See the user's manual of your cell phone for more information.
- Manually connect your cell phone to your telephone system. Refer to the user's manual of your cell phone for more information.

I cannot connect my headset with the telephone base.

- Make sure that your Bluetooth headset is not connected to any other Bluetooth device.
- Make sure that your headset is on the active devices list.

I cannot put my headset in discoverable mode.

- Refer to the user's manual of your headset for information on how to set your headset to discoverable mode.
- Make sure that the headset is not connected to any other Bluetooth device in order to successfully pair and connect to the telephone base.
- Carefully follow the pairing process on pages 23-24.
- Reset the telephone base. Unplug the unit's electrical power. Wait for approximately 15 seconds, and then plug it back in. Repeat the above suggestions.

I don't know how to search for or add new devices on my cell phone.

- Most cell phones have the Bluetooth feature in the connection or setup menus. Please refer to the user's manual of your cell phone.
- In general, press the menu key on your cell phone, and then look for the Bluetooth menu in the settings or connection menu. In the Bluetooth menu, select the option to search for or add new devices.

My cell phone disconnects with the telephone base.

- Turn off your cell phone, and then turn it on again.
- Make sure that you are not using your cell phone when on a cell call.

Appendix
Troubleshooting

My cell phone is connected to the telephone base, but I cannot make a cell call.

- Make sure that your cell phone is not in use when you are trying to make a cell call.
- For some smartphones, make sure that the cellular function is turned on.

Bluetooth system busy appears on the display.

- Make sure that your cell phone is not in use when connected and on the active devices list.
- Make sure that your cell phone or headset is not connected to any other Bluetooth device.
- Your telephone system can only use one Bluetooth device at a time.

The PIN on the telephone base does not work.

- The default PIN is **0000**.
- If you have changed the PIN, it will appear on the telephone base in the pairing process.

I cannot hear any audio on my telephone system when on a cell call.

- Make sure that your cell phone's volume is not too low or muted.
- Reset the telephone base. Unplug the unit's electrical power. Wait for approximately 15 seconds, and then plug it back in.
- Turn off your cell phone, and then turn it on again.

I cannot download contacts from my cell phone to my TL86103.

- Make sure that your cell phone is paired and connected to the base.
- Make sure you place your cell phone next to the base while downloading.
- If your cell phone does not support the download, you can send the directory from your cell phone. The system can receive the directory automatically. See the user's manual of your cell phone for more information.

I see duplicate entries in my downloaded directory.

- If you see duplicate directory entries, you can delete them manually. Another option is to download again either your SIM card or phone memory, but not both.

Appendix
Troubleshooting

Some of my cell phone contacts were not imported to my TL86103.

- Try copying the contacts from your SIM card to your cell phone memory first, and then download from your phone memory. If that doesn't work, try copying the contacts from your cell phone memory to your SIM card, and then download from your SIM card. For more information on how to transfer contacts between your SIM card and your phone memory, refer to the user's manual of your cell phone.

Can the TL86103 help the poor cell phone reception in my house?

- If your cell phone has poor reception in your home, the **TL86103** cannot improve the reception. However, if you have a location in your house with better reception, you can leave your cell phone in that location while you use **TL86103** cell line. In order for this to work, the cell phone must be within 30 feet of the telephone base for optimal performance.

The listening volume of my cell call is too loud or quiet.

During a cell call, if the listening volume is too loud or quiet, try changing the volume on your cell phone. On some cell phones, changing the volume on the cell phone affects your cell call volume on the **TL86103** handset.

The phone doesn't play my iPhone ringtone when there is an incoming call.

- Make sure the operating system of your iPhone is iOS 4.1 or later.
- Make sure you have turned on the **Cell ringer** feature (page 32).

The iPhone ringtone played is unclear or too loud with noise.

- The quality of ringtone played on your telephone is subject to individual ringtone characteristics.
- Try using another iPhone ringtone to test the quality.

Troubleshooting

My phone doesn't work at all.

- Make sure the power cord is securely plugged in.
- Make sure that the battery connector is securely plugged into the handset.
- Make sure the telephone line cord is securely and firmly plugged into the telephone base and the telephone wall jack.
- Charge the battery in the handset for at least 11 hours. For optimum daily performance, return the handset to the telephone base or charger when not in use.
- If the battery is depleted, charge the handset for at least 30 minutes before you use it. Refer to page 10 for details.
- Reset the telephone base. Unplug the electrical power. Wait for approximately 15 seconds, and then plug it back in. Allow up to one minute for the handset and telephone base to reset.
- You may need to purchase a new battery. Please refer to **Battery installation and charging** (page 13) in this user's manual.

I cannot get a dial tone.

- Try all the suggestions above.
- Move the cordless handset closer to the telephone base. You may have moved out of range.
- If the previous suggestions do not work, disconnect the telephone base from the telephone jack and connect to a different phone. If there is no dial tone on that phone either, the problem is in your wiring or telephone service. Contact your telephone service provider.
- Your line cord may be defective. Try installing a new line cord.

I cannot dial out.

- Try all the suggestions above.
- Make sure you have a dial tone before dialing. The cordless handset may take a second or two to find the telephone base and produce a dial tone. This is normal. Wait an extra second before dialing.
- Eliminate any background noise. Noise from a television, radio or other appliances may cause the phone to not dial out properly. If you cannot eliminate the background noise, first try muting the cordless handset before dialing, or dialing from another room with less background noise.
- If other phones in your home are having the same problem, contact your telephone service provider (charges may apply).

Troubleshooting

During power outage, I put a handset in the charger but the system fails to power up.

- Make sure the handset you placed in the charger base has enough charge to power up the system.
- Try removing and re-installing the handset's battery. Place the handset in the charger again.

My cordless handset isn't performing normally.

- Make sure the power cord is securely plugged into the telephone base. Plug the power adapter into a different working electrical outlet not controlled by a wall switch.
- Move the handset closer to the telephone base. You might have moved out of range.
- Reset the telephone base. Unplug the electrical power. Wait for 15 seconds, and then plug it back in. Allow up to one minute for the handset and telephone base to reset.
- Other electronic products such as HAM radios and other DECT phones can cause interference to your cordless telephone. Try installing your telephone as far away as possible from these types of electronic devices.

Out of range appears on my cordless handset.

- Ensure you plug the telephone base in properly and the power is on.
- Move the cordless handset closer to the telephone base. You may have moved out of range.
- Reset the telephone base. Unplug the electrical power. Wait for 15 seconds, and then plug it back in. Allow up to one minute for the cordless handset and telephone base to reset.
- Other electronic products such as HAM radios and other DECT phones can cause interference with your cordless phone. Try installing your phone as far away as possible from these types of electronic devices.

Troubleshooting

The batteries do not hold a charge.

- If the cordless handset is in the charger and the charge light is not on, refer to **The charge light is off** (page 143).
- Charge the battery in the cordless handset for at least ten hours. For optimum daily performance, return the cordless handset to the telephone base or charger when not in use.
- If the battery is depleted, it may take approximately 30 minutes to charge the handset before it shows **Low battery**. Refer to the table on page 13 for details.

You may need to purchase a new battery. Please refer to

Battery installation and charging in this user's manual on page 13.

I get noise, static, or weak signals even when I'm near the telephone base.

- If you subscribe to high-speed Internet service (DSL - digital subscriber line) through your telephone line, you must install a DSL filter between the telephone line cord and the telephone wall jack (page 9). The filter prevents noise and caller ID problems as a result of DSL interference. Please contact your DSL service provider for more information about DSL filters.
- You may be able to improve the performance of your cordless phone by installing your new telephone base as far as possible from any other existing cordless telephone system that may already be installed.
- Other electronic products such as HAM radios and other DECT phones can cause interference with your cordless phone. Try installing your phone as far away as possible from these types of electronic devices.
- Do not install this phone near a microwave oven or on the same electrical outlet. You may experience decreased performance while the microwave oven is operating.
- If you plug your phone in with a modem or a surge protector, plug the phone (or modem/surge protector) into a different location. If this does not solve the problem, relocate your phone or modem farther apart from one another, or use a different surge protector.
- Move your phone to a higher location. The phone may have better reception in a high area.
- If other phones in your home are having the same problem, contact your telephone service provider (charges may apply).

I hear other calls while using my phone.

- Disconnect the telephone base from the telephone jack, and plug in a different telephone. If you still hear other calls, call your telephone service provider.

Troubleshooting

I experience poor sound quality when using the handset speakerphone.

- For increased sound quality while using the handset speakerphone, place the handset on a flat surface with the dial pad facing up.
- When using a speakerphone, controlling background noise in your environment is essential. While you are listening to your party, press **MUTE/DELETE** to temporarily turn your microphone off. When it is your turn to speak, remember to press **MUTE/DELETE** again to turn the microphone on.
- Excessive background noise will cause a speakerphone to fade in and out. Try controlling the background noise by turning off audio devices near the speakerphone. Also, try to avoid interrupting the person at the other end of the conversation while they are speaking. If background noise cannot be controlled, you should terminate speakerphone operation and return to normal handset mode.

My cordless handset does not ring when I receive a call.

- Make sure that the ringer is not off. Refer to **Ringer volume** on page 32 in this user's manual.
- Make sure you plug in the telephone line cord securely into the telephone base and the telephone jack. Make sure you plug in the power cord securely.
- The cordless handset may be too far from the telephone base.
- Charge the battery in the cordless handset for at least ten hours. For optimum daily performance, return the cordless handset to the telephone base or charger when not in use.
- You may have too many extension phones on your telephone line to allow all of them to ring simultaneously. Try unplugging some of the other phones.
- The layout of your home or office may be limiting the operating range. Try moving the telephone base to another location, preferably to a higher location.
- If other phones in your home are having the same problem, contact your telephone service provider (charges may apply).
- Test a working phone at the phone jack. If another phone has the same problem, contact your telephone service provider (charges may apply).
- Other electronic products can cause interference with your cordless phone. Try installing your phone as far away as possible from electronic devices such as television sets, VCRs, or other cordless telephones.
- Remove the battery. Install the battery again and place the cordless handset into the telephone base. Wait for the cordless handset to reestablish its connection with the telephone base. Allow up to one minute for this to take place.
- Your line cord may be defective. Try installing a new line cord.

Troubleshooting

My calls cut in and out while I'm using my cordless handset.

- Other electronic products such as HAM radios and other DECT phones can cause interference with your cordless phone. Try installing your phone as far away as possible from these types of electronic devices.
- Do not install this phone near a microwave oven or on the same electrical outlet. You may experience decreased performance while the microwave oven is operating.
- If you plug your phone in with a modem or surge protector, plug the phone (or modem/surge protector) into a different location. If this does not solve the problem, relocate your phone or modem farther apart from one another, or use a different surge protector.
- Move your telephone base to a higher location. The phone may have better reception when installed in a high area.
- If other phones in your home are having the same problem, contact your telephone service provider (charges may apply).

The charge light is off.

- Make sure you plug the power and line cords in correctly and securely.
- Unplug the electrical power. Wait for 15 seconds, and then plug it back in. Allow up to one minute for the cordless handset and telephone base to reset.
- Clean the cordless handset, charger and telephone base charging contacts each month with a pencil eraser or cloth.
- A blinking **CHARGE** light is an indication that the battery is not connected to the handset or is missing completely. Ensure that the battery is installed properly.

My caller ID isn't working.

- Caller ID is a subscription service. You must subscribe to this service from your telephone service provider for this feature to work on your phone.
- The caller may be calling from an area that supports caller ID.
- Both your and your caller's telephone service providers must use caller ID compatible equipment.
- If you subscribe to high-speed Internet service (DSL - digital subscriber line) through your telephone line, you must install a DSL filter between the telephone line cord and the telephone wall jack (page 9). The filter prevents noise and caller ID problems resulting from DSL interference. Please contact your DSL service provider for more information about DSL filters.

Appendix
Troubleshooting

I cannot retrieve voicemail messages.

- Your telephone has both a built-in answering system and voicemail indication. They are independent features and each alerts you to new messages differently (page 112). If you subscribe to voicemail service from your telephone service provider, contact your telephone service provider for more information on how to access your voicemail.

I've set my LCD language to Spanish or French and I don't know how to change it back to English.

- Press **MENU** on your handset or base in idle mode, and then enter **364#** on the handset or base. You hear a confirmation tone.

I subscribe to a nontraditional telephone service that uses my computer to establish connections, and my telephone doesn't work.

- Make sure your computer is powered on.
- Make sure your Internet connection is working properly.
- Make sure that the software is installed and running for your nontraditional telephone service.
- If you are using a firewall, it may prevent access to your nontraditional telephone service provider. Contact your service provider for more information.

Common cure for electronic equipment.

If the telephone does not seem to be responding normally, try putting the cordless handset in the charger. If it does not fix the problem, do the following (in the order listed):

1. Disconnect the power to the telephone base.
2. Disconnect the cordless handset battery.
3. Wait a few minutes.
4. Connect power to the telephone base.
5. Remove the battery. Replace the battery and place the cordless handset into the telephone base or charger.
6. Wait for the cordless handset to reestablish its connection with the telephone base. Allow up to one minute for this to take place.

Appendix
Troubleshooting

Taking care of your telephone

- Your cordless telephone contains sophisticated electronic parts, so you must treat it with care.
- Avoid rough treatment.
- Place the handset down gently.
- Save the original packing materials to protect your telephone if you ever need to ship it.

Avoid water

- You can damage your telephone if it gets wet. Do not use the handset in the rain, or handle it with wet hands. Do not install the telephone base near a sink, bathtub or shower.

Electrical storms

- Electrical storms can sometimes cause power surges harmful to electronic equipment. For your own safety, take caution when using electric appliances during storms.

Cleaning your telephone

- Your telephone has a durable plastic casing that should retain its luster for many years. Clean it only with a soft cloth slightly dampened with water or mild soap.
- Do not use excess water or cleaning solvents of any kind.

Remember that electrical appliances can cause serious injury if used when you are wet or standing in water. If the telephone base should fall into water, DO NOT RETRIEVE IT UNTIL YOU UNPLUG THE POWER CORD AND TELEPHONE LINE CORDS FROM THE WALL. Pull the unit out by the unplugged cords.

Appendix
Troubleshooting

System does not receive caller ID when on a call.

- Make sure you subscribe to caller ID with call waiting features from your telephone service provider. Caller ID features works only if both you and the caller are in areas offering caller ID service, and if both telephone service providers use compatible equipment.

Incomplete messages.

- If a caller leaves a very long message, part of it may be lost when the system disconnects the call after the maximum recording time you have set.
- If the caller pauses for longer than seven seconds, the system stops recording and disconnects the call.
- If the system's memory becomes full during a message, the system stops recording and disconnects the call.
- If the caller's voice is very soft, the system may stop recording and disconnect the call.

Difficulty hearing messages.

- Press **VOLUME/▲** to increase the telephone base speaker volume.
- Press **▲/VOLUME** to adjust the message playback volume on a handset.

System does not answer after the correct number of rings.

- Make sure the answering system is on. **L1) Ans sys off** or **L2) Ans sys off** should not appear on the handset screen and the **☎/LINE 1 ANS ON/OFF** or **☎/LINE 2 ANS ON/OFF** light on the telephone base should be on.
- If toll saver is activated, the number of rings changes to two when you have new messages stored (pages 107).
- If the memory is full or the system is off, the system will answer after ten rings.
- In some cases, the answering system is affected by the ringing system used by your telephone service provider.
- If you subscribe to voicemail service, change the number of rings so that your answering system answers before your voicemail answers (pages 107). To determine how many rings activate your voicemail, contact your telephone service provider.
- If there is a fax machine connected to the same telephone line, try disconnecting the fax machine. If that solves the problem, consult your fax machine documentation for information on compatibility with answering systems.

Appendix
Troubleshooting

System does not respond to remote commands.

- Make sure to enter your remote access code correctly (page 122).
- Make sure you are calling from a touch-tone phone. When you dial a number, you should hear tones. If you hear clicks, the phone is not a touch-tone telephone and cannot activate the answering system.
- The answering system may not detect the remote access code while your announcement is playing. Try waiting until the announcement is over before entering the code.
- There may be interference on the phone line you are using. Press dialing keys firmly.

System does not record messages.

- Make sure the answering system is on. **Ans sys off** should not show on the handset and the **☎/LINE 1** or **☎/LINE 2** light on the telephone base should be on.
- Make sure the memory of the answering system is not full.
- If you subscribe to voicemail service, change the number of rings so that your answering system answers before your voicemail answers (pages 107). To determine how many rings activate your voicemail, contact your telephone service provider.
- If there is a fax machine connected to the same telephone line, try disconnecting the fax machine. If that solves the problem, consult your fax machine documentation for information on compatibility with answering systems.

System announces, “Time and day not set.”

- You need to reset the system clock (page 36).

Outgoing announcement is not clear.

- When you record your announcement, make sure you speak in a normal tone of voice, about nine inches from the handset or the telephone base.
- Make sure there is no background noise (TV, music, etc.) while recording.

New voicemail and  show on the screens, and I don’t know why.

- Your telephone has both a built-in answering system and voicemail indication. If **New voicemail** and  appear on the screens, and then your telephone has received a signal from your telephone service provider that you have a voicemail message waiting for you to retrieve from them. Contact your telephone service provider for more information on how to access your voicemail.

Important safety information



This symbol is to alert you to important operating or servicing instructions that may appear in this user's manual. Always follow basic safety precautions when using this product to reduce the risk of injury, fire, or electric shock.

Safety information

- Read and understand all instructions in the user's manual. Observe all markings on the product.
- Avoid using a telephone during a thunderstorm. There might be a slight chance of electric shock from lightning.
- Do not use a telephone in the vicinity of a gas leak. Under certain circumstances, a spark may be created when the adapter is plugged into the power outlet, or when the handset is replaced in its cradle. This is a common event associated with the closing of any electrical circuit. The user should not plug the phone into a power outlet, and should not put a charged handset into the cradle, if the phone is located in an environment containing concentrations of flammable or flame-supporting gases, unless there is adequate ventilation. A spark in such an environment could create a fire or explosion. Such environments might include: medical use of oxygen without adequate ventilation; industrial gases (cleaning solvents; gasoline vapors; etc.); a leak of natural gas; etc.
- Do not use this product near water, or when you are wet. For example, do not use it in a wet basement or shower, or next to a swimming pool, bathtub, kitchen sink, or laundry tub. Do not use liquids or aerosol sprays for cleaning. If the product comes in contact with any liquids, unplug any line or power cord immediately. Do not plug the product back in until it has dried thoroughly.
- Install this product in a protected location where no one can trip over any line or power cords. Protect cords from damage or abrasion.
- If this product does not operate normally, read the **Troubleshooting** section on pages 135-147 of this user's manual. If you cannot solve the problem, or if the product is damaged, refer to the **Limited warranty** section on pages 153-154. Do not open this product except as may be directed in your user's manual. Opening the product or reassembling it incorrectly may expose you to hazardous voltages or other risks.
- Replace batteries only as described in your user's manual (page 13). Do not burn or puncture batteries — they contain caustic chemicals.
- The power adapters are intended to be correctly oriented in a vertical or floor mount position. The prongs are not designed to hold the plug in place if it is plugged into a ceiling, under-the-table or cabinet outlet.



CAUTION: Use only the power adapter provided with this product. To obtain a replacement, visit our website at **www.telephones.att.com**, or call **1 (800) 222-3111**. In Canada, dial **1 (866) 288-4268**.

For more detailed instructions, refer to the online Complete user's manual at **www.telephones.att.com/manuals**.

Important safety information

Especially about cordless telephones

- **Privacy:** The same features that make a cordless telephone convenient create some limitations. Telephone calls are transmitted between the telephone base and the handset by radio waves, so there is a possibility that your cordless telephone conversations could be intercepted by radio receiving equipment within range of the cordless handset. For this reason, you should not think of cordless telephone conversations as being as private as those on corded telephones.
- **Electrical power:** The telephone base of this cordless telephone must be connected to a working electrical outlet which is not controlled by a wall switch. Calls cannot be made from the handset if the telephone base is unplugged, switched off or if the electrical power is interrupted.
- **Potential TV interference:** Some cordless telephones operate at frequencies that may cause interference to TVs and VCRs. To minimize or prevent such interference, do not place the telephone base of the cordless telephone near or on top of a TV or VCR. If interference is experienced, moving the cordless telephone farther away from the TV or VCR will often reduce or eliminate the interference.
- **Rechargeable batteries:** This product contains nickel-metal hydride rechargeable batteries. Exercise care in handling batteries in order not to create a short circuit with conductive material such as rings, bracelets, and keys. The battery or conductor may overheat and cause harm. Observe proper polarity between the battery and the battery charger.
- **Nickel-metal hydride rechargeable batteries:** Dispose of these batteries in a safe manner. Do not burn or puncture. Like other batteries of this type, if burned or punctured, they could release caustic material which could cause injury.



The RBRC™ Seal means that the manufacturer is voluntarily participating in an industry program to collect and recycle nickel-metal hydride rechargeable batteries when taken out of service within the United States. These batteries may be taken to a participating local retailer of replacement batteries or recycling center. Or you may call 1 (800) 8-BATTERY for locations accepting spent Ni-MH batteries.

Precautions for users of implanted cardiac pacemakers

Cardiac pacemakers (applies only to digital cordless telephones): Wireless Technology Research, LLC (WTR), an independent research entity, led a multidisciplinary evaluation of the interference between portable wireless telephones and implanted cardiac pacemakers. Supported by the U.S. Food and Drug Administration, WTR recommends to physicians that:

Pacemaker patients:

- Should keep wireless telephones at least six inches from the pacemaker.
- Should NOT place wireless telephones directly over the pacemaker, such as in a breast pocket, when it is turned ON.
- Should use the wireless telephone at the ear opposite the pacemaker.

WTR's evaluation did not identify any risk to bystanders with pacemakers from other persons using wireless telephones.

ECO mode

This power conserving technology reduces power consumption for optimal battery performance. The ECO mode activates automatically whenever the handset is synchronized with the telephone base.

Especially about telephone answering systems

Two-way recording: This unit does not sound warning beeps to inform the other party that the call is being recorded. To ensure that you are in compliance with any federal or state regulations regarding recording a telephone call, you should start the recording process and then inform the other party that you are recording the conversation.

SAVE THESE INSTRUCTIONS

Appendix

Energy-saving charging mode

When this mode is activated, all functions of the cordless handsets, except handset battery charging, will be disabled.

To activate the energy-saving charging mode:

1. Press and hold **HOLD** on the telephone base for about 10 seconds in idle mode. The telephone base shows **Deregister all devices?** Release **HOLD**.
2. Quickly press **HOLD** again or press **YES** within 5 seconds.



When the handsets successfully enter the energy-saving charging mode, all handset screens display **To register, see user manual**.

When the handsets fail to enter this mode, repeat Step 1 to Step 2 above.

To deactivate the energy-saving charging mode:

Register your handsets back to the telephone base. See page 124 for handset registration instructions.

Appendix FCC Part 68 and ACTA

This equipment complies with Part 68 of the FCC rules and with technical requirements adopted by the Administrative Council for Terminal Attachments (ACTA). The label on the back or bottom of this equipment contains, among other things, a product identifier in the format US:AAAEQ##TXXXX. This identifier must be provided to your telephone service provider upon request.

The plug and jack used to connect this equipment to premises wiring and the telephone network must comply with the applicable Part 68 rules and technical requirements adopted by ACTA. A compliant telephone cord and modular plug is provided with this product. It is designed to be connected to a compatible modular jack that is also compliant. An RJ11 jack should normally be used for connecting to a single line and an RJ14 jack for two lines. See Installation Instructions in the user's manual.

The Ringer Equivalence Number (REN) is used to determine how many devices you may connect to your telephone line and still have them ring when you are called. The REN for this product is encoded as the 6th and 7th characters following the US: in the product identifier (e.g., if ## is 03, the REN is 0.3). In most, but not all areas, the sum of all RENs should be five (5.0) or less. For more information, please contact your telephone service provider.

This equipment may not be used with Party Lines. If you have specially wired alarm dialing equipment connected to your telephone line, ensure the connection of this equipment does not disable your alarm equipment. If you have questions about what will disable the alarm equipment, consult your telephone service provider or a qualified installer.

If this equipment is malfunctioning, it must be unplugged from the modular jack until the problem has been corrected. Repairs to this telephone equipment can only be made by the manufacturer or its authorized agents. For repair procedures, follow the instructions outlined under the Limited Warranty.

If this equipment is causing harm to the telephone network, the telephone service provider may temporarily discontinue your telephone service. The telephone service provider is required to notify you before interrupting service. If advance notice is not practical, you will be notified as soon as possible. You will be given the opportunity to correct the problem and the telephone service provider is required to inform you of your right to file a complaint with the FCC. Your telephone service provider may make changes in its facilities, equipment, operation, or procedures that could affect the proper functioning of this product. The telephone service provider is required to notify you if such changes are planned.

If this product is equipped with a corded or cordless handset, it is hearing aid compatible.

If this product has memory dialing locations, you may choose to store emergency telephone numbers (e.g., police, fire, medical) in these locations. If you do store or test emergency numbers, please:

- Remain on the line and briefly explain the reason for the call before hanging up.
- Perform such activities in off-peak hours, such as early morning or late evening.

Industry Canada

Operation is subject to the following two conditions: (1) this device may not cause harmful interference, and (2) this device must accept any interference, including interference that may cause undesired operation.

The term "IC:" before the certification/registration number only signifies that the Industry Canada technical specifications were met.

The Ringer Equivalence Number (REN) for this terminal equipment is 1.0. The REN is an indication of the maximum number of devices allowed to be connected to a telephone interface. The termination on an interface may consist of any combination of devices subject only to the requirement that the sum of the RENs of all the devices does not exceed five.

This product meets the applicable Industry Canada technical specifications.

Appendix FCC Part 15

This equipment has been tested and found to comply with the requirements for a Class B digital device under Part 15 of the Federal Communications Commission (FCC) rules.

These requirements are intended to provide reasonable protection against harmful interference in a residential installation. This equipment generates, uses and can radiate radio frequency energy and, if not installed and used in accordance with the instructions, may cause harmful interference to radio communications. However, there is no guarantee that interference will not occur in a particular installation.

If this equipment does cause harmful interference to radio or television reception, which can be determined by turning the equipment off and on, the user is encouraged to try to correct the interference by one or more of the following measures:

- Reorient or relocate the receiving antenna.
- Increase the separation between the equipment and receiver.
- Connect the equipment into an outlet on a circuit different from that to which the receiver is connected.
- Consult the dealer or an experienced radio/TV technician for help.

Changes or modifications to this equipment not expressly approved by the party responsible for compliance could void the user's authority to operate the equipment.

This device complies with Part 15 of the FCC rules. Operation is subject to the following two conditions: (1) this device may not cause harmful interference, and (2) this device must accept any interference received, including interference that may cause undesired operation. Privacy of communications may not be ensured when using this telephone.

To ensure safety of users, the FCC has established criteria for the amount of radio frequency energy that can be safely absorbed by a user or bystander according to the intended usage of the product. This product has been tested and found to comply with the FCC criteria. The handset may be safely held against the ear of the user. The telephone base shall be installed and used such that parts of the user's body other than the hands are maintained at a distance of approximately 20cm (8 inches) or more.

This Class B digital apparatus complies with Canadian requirement:
CAN ICES-3 (B)/NMB-3(B)

For body worn operation, this handset has been tested and meets the FCC RF exposure guidelines when used with the accessories supplied or designated for this product. Use of other accessories may not ensure compliance with FCC RF exposure guidelines.

Appendix

Limited warranty

The AT&T brand is used under license - any repair, replacement or warranty service, and all questions about this product should be directed to our website at www.telephones.att.com or call **1 (800) 222-3111**. In Canada, dial **1 (866) 288-4268**.

For more detailed instructions, refer to the online Complete user's manual at www.telephones.att.com/manuals.

1. What does this limited warranty cover?

The manufacturer of this AT&T branded product warrants to the holder of a valid proof of purchase ("CONSUMER" or "you") that the product and all accessories provided in the sales package ("PRODUCT") are free from defects in material and workmanship, pursuant to the following terms and conditions, when installed and used normally and in accordance with the PRODUCT operating instructions. This limited warranty extends only to the CONSUMER for products purchased and used in the United States of America and Canada.

2. What will be done if the PRODUCT is not free from defects in materials and workmanship during the limited warranty period ("materially defective PRODUCT")?

During the limited warranty period, the manufacturer's authorized service representative repairs or replaces at the manufacturer's option, without charge, a materially defective PRODUCT. If the manufacturer repairs the PRODUCT, they may use new or refurbished replacement parts. If the manufacturer chooses to replace the PRODUCT, they may replace it with a new or refurbished PRODUCT of the same or similar design. The manufacturer will retain the defective parts, modules, or equipment. Repair or replacement of the PRODUCT, at the manufacturer's option, is your exclusive remedy. The manufacturer returns the repaired or replacement products to you in working condition. You should expect the repair or replacement to take approximately 30 days.

3. How long is the limited warranty period?

The limited warranty period for the PRODUCT extends for ONE (1) YEAR from the date of purchase. If the manufacturer repairs or replaces a materially defective PRODUCT under the terms of this limited warranty, this limited warranty also applies to repaired or replacement PRODUCT for a period of either (a) 90 days from the date the repaired or replacement PRODUCT is shipped to you or (b) the time remaining on the original one-year limited warranty; whichever is longer.

4. What is not covered by this limited warranty?

This limited warranty does not cover:

- PRODUCT that has been subjected to misuse, accident, shipping or other physical damage, improper installation, abnormal operation or handling, neglect, inundation, fire, water, or other liquid intrusion; or
- PRODUCT that has been damaged due to repair, alteration, or modification by anyone other than an authorized service representative of the manufacturer; or
- PRODUCT to the extent that the problem experienced is caused by signal conditions, network reliability or cable or antenna systems; or
- PRODUCT to the extent that the problem is caused by use with non-AT&T accessories; or
- PRODUCT whose warranty/quality stickers, PRODUCT serial number plates or electronic serial numbers have been removed, altered or rendered illegible; or
- PRODUCT purchased, used, serviced, or shipped for repair from outside the United States of America or Canada, or used for commercial or institutional purposes (including but not limited to products used for rental purposes); or
- PRODUCT returned without a valid proof of purchase (see item 6 below); or
- Charges for installation or setup, adjustment of customer controls, and installation or repair of systems outside the unit.

Appendix
Limited warranty

5. How do you get warranty service?

To obtain warranty service in the United States of America, visit

www.telephones.att.com or call **1 (800) 222-3111**. In Canada, please dial **1 (866) 288-4268**.

For more detailed instructions, refer to the online Complete user's manual at

www.telephones.att.com/manuals.

NOTE: Before calling for service, please review the user's manual. A check of the PRODUCT's controls and features might save you a service call.

Except as provided by applicable law, you assume the risk of loss or damage during transit and transportation and are responsible for delivery or handling charges incurred in the transport of the PRODUCT(s) to the service location. The manufacturer will return repaired or replaced PRODUCT under this limited warranty. Transportation, delivery or handling charges are prepaid. The manufacturer assumes no risk for damage or loss of the PRODUCT in transit. If the PRODUCT failure is not covered by this limited warranty, or proof of purchase does not meet the terms of this limited warranty, the manufacturer notifies you and requests that you authorize the cost of repair prior to any further repair activity. You must pay for the cost of repair and return shipping costs for the repair of products that are not covered by this limited warranty.

6. What must you return with the PRODUCT to get warranty service?

You must:

- a. Return the entire original package and contents including the PRODUCT to the service location along with a description of the malfunction or difficulty; and
- b. Include "valid proof of purchase" (sales receipt) identifying the PRODUCT purchased (PRODUCT model) and the date of purchase or receipt; and
- c. Provide your name, complete and correct mailing address, and telephone number.

7. Other limitations

This warranty is the complete and exclusive agreement between you and the manufacturer of this AT&T branded PRODUCT. It supersedes all other written or oral communications related to this PRODUCT. The manufacturer provides no other warranties for this PRODUCT. The warranty exclusively describes all of the manufacturer's responsibilities regarding the PRODUCT. There are no other express warranties. No one is authorized to make modifications to this limited warranty and you should not rely on any such modification.

State/Provincial Law Rights: This warranty gives you specific legal rights, and you might also have other rights that vary from state to state or province to province.

Limitations: Implied warranties, including those of fitness for a particular purpose and merchantability (an unwritten warranty that the PRODUCT is fit for ordinary use) are limited to one year from date of purchase. Some states/provinces do not allow limitations on how long an implied warranty lasts, so the above limitation might not apply to you. In no event shall the manufacturer be liable for any indirect, special, incidental, consequential, or similar damages (including, but not limited to lost profits or revenue, inability to use the PRODUCT or other associated equipment, the cost of substitute equipment, and claims by third parties) resulting from the use of this PRODUCT. Some states/provinces do not allow the exclusion or limitation of incidental or consequential damages, so the above limitation or exclusion might not apply to you.

Please retain your original sales receipt as proof of purchase.

Appendix
 Technical specifications

RF frequency band	DECT frequency: 1921.536 — 1928.448 MHz Bluetooth frequency: 2402.000 — 2480.000 MHz
Channels	DECT channel: 5 Bluetooth channel: 79
Operating temperature	32°F — 122°F 0°C — 50°C
Telephone base voltage (AC voltage, 60Hz)	96 — 129 Vrms
Telephone base voltage (AC adapter output)	6VDC @ 600mA 5.1VDC @1000mA
Handset battery	2.4VDC 400mAh, AAx2, Ni-MH
Charger voltage (AC adapter output)	6VAC @300mA

Operation	Operating time*
Talk time (cordless handset)	up to 7 hours
Talk time (cordless handset speakerphone)	up to 5 hours
Standby	up to 7 days

* Operating times vary depending on your actual use and the age of the battery.

DECT 6.0 digital technology

The AT&T DECT 6.0 products offer unsurpassed range performance and sound clarity. This is achieved through a unique antenna design and advances in noise-filtering technology. An independent laboratory has confirmed that AT&T DECT 6.0 products perform up to 45% better in range competitions against similarly equipped phones of the leading competition. Now calls can be taken in the basement, backyard and garage with exceptional sound quality. can be taken in the basement, backyard and garage with exceptional sound quality.

Telephone operating range

This cordless telephone operates within the maximum power allowed by the Federal Communications Commission (FCC). Even so, this handset and telephone base can communicate over only a certain distance — which can vary with the locations of the telephone base and handset, the weather, and the construction of your home or office.

Redefining long range coverage and clarity

This telephone base comes with an antenna which gives much better clarity and covers a longer range than before.

HD audio

HD audio improves sound quality by expanding and rebuilding frequencies that are lost with traditional phone calls. There is no additional telephone service requirement to use HD audio. It is designed to work with standard telephone service. Your system will automatically enhance all received sound with HD audio.

Simulated full duplex handset speakerphone

The simulated full duplex speakerphone on your handset allows both ends of a call to speak and be heard at the same time. Optimal performance is subject to external factors and individual usage.

Index
Index

A

Add a Bluetooth headset 23, 25, 27
Add a cell phone 21
Alert tones
 telephone base 119, 120
Announcement 96
Answer a cell call 47
Answer a cell call while on a home call 49
Answer a home call 44
Answer an incoming call during PTT 75
Answering system and voicemail 105
Answering system settings 96–99

B

Battery charging 13
Battery installation 13
Bluetooth 17–22
Bluetooth features 17
Bluetooth setup 21–24

C

Caller ID (CID)
 add entries to phone directory 94
 dial entries 91
Call waiting on the cell line 48
Cell call 47–48
Cell phone download directory 28, 29
Connect an active device 30

D

Delete all old messages 111
Delete a message 109–110
Dialing from a record in the caller ID history 91
Directory 77–92
 edit entries 84
 name search 83
Download directory 28, 29
DSL 9, 10

E

End a cell call 47

End a home call 44
End mute 57
Energy-saving charging mode 141
Expand your telephone system 115

F

Find handset 55

H

HD audio 146
Headset 23
Hold 58
Home directory 77

I

Important safety information 139–140
Intercom 65–67, 67–69

L

Limited warranty 144–145
Listening volume 57, 58

M

Make a cell call 47
Make a home call 44
Make an outgoing call during PTT 76
Memory match 89
Memos 112
Message
 alert tone 103
 playback 108–111
Message capacity 106
Mute 57, 59

O

Operating range 146

P

Paging 55
Phonebook 77
PTT 70–73
Pulse dialing 40
Push-to-talk 70–73

Index
Index

Q

Quick reference guide 5–9

R

Record announcement 96, 97
Remote access code 113
Repeat messages 109, 110
Replace a handset 116
Ringtone share 17

S

Safety information 139–140
Share an outside call 56
Skip messages 109, 110
Softphone call 57
Speakerphone 55
Stop messages 109, 110

T

Take a call off mute 57
Telephone base
 screen icons 118
Telephone base installation 9, 10
Telephone operating range 146
Troubleshooting 126–138

U

USB port 7, 11

V

Voice command 58
Voicemail 105
Volume 32, 57, 58

W

Wall mounting 14
Warranty 144–145
Website 41

Remote access wallet card

The wallet card below lists the commands needed to control your answering system from any touch-tone telephone.

Cut along dotted line.



Call your telephone number, and then enter your 2-digit remote access code

Action	Remote command
Play all messages	1
Play new messages.....	2
Delete the message.....	3 (during message playback)
Delete all old messages	33
Repeat or go back.....	4
Stop.....	5
Help menu	*5
Skip the message.....	6
Record announcement	*7
Turn system on or off	0
End remote access call.....	8 (or hang up)

Fold here.

Model: TL86103
Type: DECT 6.0 cordless telephone/answering system with BLUETOOTH® wireless technology

© 2013 Advanced American Telephones. All Rights Reserved.
AT&T and the AT&T logo are trademarks of AT&T Intellectual Property licensed to Advanced American Telephones, San Antonio, TX 78219.
Printed in China.



www.telephones.att.com

The *Bluetooth*[®] word mark and logos are owned by Bluetooth SIG, Inc. and any use of such marks by Advanced American Telephones and its parent, VTech Holdings Limited, is under license. VTech Holdings Limited is a member of Bluetooth SIG, Inc. Other trademarks and trade names are those of their respective owners.

© 2013 Advanced American Telephones. All Rights Reserved.

AT&T and the AT&T logo are trademarks of AT&T Intellectual Property licensed to Advanced American Telephones, San Antonio, TX 78219.

Connect to Cell™ is a trademark of Advanced American Telephones.

Android[®] and Google Play[®] are registered trademarks of Google Inc.

iPhone[®] is a registered trademark of Apple, Inc.

Printed in China. Issue 1 AT&T 09/13.

91-007268-010-100