

vtech®

ErisStation®

Conference Phone
with Four Wireless Mics

User's manual

businessphones.vtech.com



Model: VCS704

DECT 6.0

Congratulations

on purchasing your new VTech product. Before using this product, please read **Important safety instructions** on page i of this manual.

This manual includes the information and procedures necessary to install and operate your new VTech product. Please review this manual thoroughly to ensure proper installation and operation of this innovative and feature rich VTech product. For support, shopping, and everything new at VTech, visit our website at <http://businessphones.vtech.com>.

Important safety instructions

When using your ErisStation® Conference Phone, basic safety precautions should always be followed to reduce the risk of fire, electric shock and injury, including the following:

1. Read and understand all instructions.
2. Follow all warnings and instructions marked on the product.
3. Unplug this product from the wall outlet before cleaning. Do not use liquid or aerosol cleaners. Use a damp cloth for cleaning.
4. Do not use this product near water such as near a bathtub, wash bowl, kitchen sink, laundry tub or swimming pool, or in a wet basement or shower.
5. For pluggable equipment, the socket-outlet shall be installed near the equipment and shall be easily accessible.
6. **CAUTION:** Use only the batteries indicated in this manual. There may be a risk of explosion if a wrong type of battery is used. Use only the supplied rechargeable battery or replacement battery pack (BT183642/BT283642). Do not dispose of batteries in a fire. They may explode. Dispose of used battery according to the information in **The RBRC® seal**.
7. Do not place this product on an unstable table, shelf, stand or other unstable surfaces.
8. Slots and openings in the back or bottom of the base unit and wireless mic are provided for ventilation. To protect them from overheating, these openings must not be blocked by placing the product on a soft surface such as a bed, sofa or rug. This product should never be placed near or over a radiator or heat register. This product should not be placed in any area where proper ventilation is not provided.
9. Use only the adapter included with this product. Incorrect adapter polarity or voltage can seriously damage the product. Base unit power adapter: Input 100-240V AC 50/60 Hz; Output: 9V DC 1500mA.
10. This product should be operated only from the type of power source indicated on the marking label. If you are not sure of the type of power supply in your office, consult your dealer or local power company.
11. Do not allow anything to rest on the power cord. Do not install this product where the cord may be walked on.
12. Never push objects of any kind into this product through the slots in the base unit or wireless mic because they may touch dangerous voltage points or create a short circuit. Never spill liquid of any kind on the product.
13. To reduce the risk of electric shock, do not disassemble this product, but take it to an authorized service facility. Opening or removing parts of the base unit or wireless mic other than specified access doors may expose you to dangerous voltages or other risks. Incorrect reassembling can cause electric shock when the product is subsequently used.
14. Do not overload wall outlets and extension cords.
15. Unplug this product from the wall outlet and refer servicing to an authorized service facility under the following conditions:
 - When the power supply cord or plug is damaged or frayed.
 - If liquid has been spilled onto the product.
 - If the product has been exposed to rain or water.
 - If the product does not operate normally by following the operating instructions. Adjust only those controls that are covered by the operation instructions. Improper adjustment of other controls may result in damage and often requires extensive work by an authorized technician to restore the product to normal operation.
 - If the product has been dropped and the base unit and/or wireless mic has been damaged.
 - If the product exhibits a distinct change in performance.
16. Avoid using the ErisStation® Conference Phone during an electrical storm. There is a remote risk of electric shock from lightning.

Important Safety Instructions

17. Do not use the ErisStation® Conference Phone to report a gas leak in the vicinity of the leak. Under certain circumstances, a spark may be created when the adapter is plugged into the power outlet, or when the wireless mic is replaced in its cradle. This is a common event associated with the closing of any electrical circuit. The user should not plug the phone into a power outlet, and should not put a charged wireless mic onto the charging cradle, if the phone is located in an environment containing concentrations of flammable or flame-supporting gases, unless there is adequate ventilation. A spark in such an environment could create a fire or explosion. Such environments might include: medical use of oxygen without adequate ventilation; industrial gases (cleaning solvents; gasoline vapors; etc.); a leak of natural gas; etc.
18. Only put the wireless mic next to your mouth when it is in normal talk mode.
19. The power cables are intended to be correctly oriented in a vertical or floor mount position. The prongs are not designed to hold the plug in place if it is plugged into a ceiling or cabinet outlet.

SAVE THESE INSTRUCTIONS

Precautions for users of implanted cardiac pacemakers

Cardiac pacemakers (applies only to digital cordless telephones):

Wireless Technology Research, LLC (WTR), an independent research entity, led a multidisciplinary evaluation of the interference between portable wireless telephones and implanted cardiac pacemakers. Supported by the U.S. Food and Drug Administration, WTR recommends to physicians that:

Pacemaker patients

- Should keep the wireless telephone at least six inches from the pacemaker.
- Should NOT place wireless telephones directly over the pacemaker, such as in a breast pocket, when it is turned ON.
- Should use the wireless telephone at the ear opposite the pacemaker.

WTR's evaluation did not identify any risk to bystanders with pacemakers from other persons using wireless telephones.

About wireless mics

- **Privacy:** The same features that make a wireless mic convenient create some limitations. Calls on conference phones are transmitted between the base unit and the wireless mic by radio waves, so there is a possibility that the wireless mic conversations could be intercepted by radio receiving equipment within range of the wireless mic. For this reason, you should not think of conference phone conversations as being as private as those on corded telephones.
- **Electrical power:** The base unit of this conference phone must be connected to a working electrical outlet. The electrical outlet should not be controlled by a wall switch. Calls cannot be made from the conference phone if the base unit is unplugged, switched off or if the electrical power is interrupted.
- **Potential TV interference:** Wireless mic operates at frequencies that may cause interference to televisions and VCRs. To minimize or prevent such interference, do not place the base unit near or on top of a TV or VCR. If interference is experienced, moving the wireless mic farther away from the TV or VCR often reduces or eliminates the interference.
- **Rechargeable batteries:** Exercise care in handling batteries in order not to create a short circuit with conducting material such as rings, bracelets and keys. The battery or conductor may overheat and cause harm.
- **Nickel-metal hydride rechargeable batteries:** Dispose of these batteries in a safe manner. Do not burn or puncture. Like other batteries of this type, if burned or punctured, they could release caustic material which could cause injury.

Table of contents

Introduction.....	1	Key tone	17
About ErisStation® Conference Phone with Wireless Mics.....	1	Dial mode	17
Parts checklist	1	Area code	17
Getting Started.....	2	Loop gain.....	18
Connect base unit.....	2	Reset	18
Install battery to the wireless mic.....	3	Phonebook.....	19
Before use	4	About the phonebook	19
Base unit overview (front).....	5	Add a phonebook entry	19
Base unit overview (rear).....	7	Review phonebook entries	20
Wireless mic overview	8	Alphabetical search	20
Status indicators overview.....	9	Dial a phonebook entry.....	20
Conference phone operation ...	10	Edit a phonebook entry.....	21
Make a call	10	Delete a phonebook entry	21
Answer a call	10	Delete all phonebook entries	22
End a call.....	10	Speed dial.....	22
Redial	10	Assign a speed dial entry	22
Predial a call	10	Reassign a speed dial entry	23
Volume	10	Dial a speed dial number.....	23
Mute.....	11	Delete a speed dial entry.....	23
Temporarily silencing the ringer	11	Call log.....	24
3-way conference	11	About caller ID	24
Call waiting	12	Call log.....	24
Paging	12	Missed call indicator	24
Chain dialing.....	13	Review the call log.....	25
Settings	14	Save a call log entry to phonebook ...	25
Using the Menu	14	Dial a call log entry	26
Ringer volume	14	Delete a call log entry	26
Ringer tone.....	15	Delete all call log entries.....	26
Set date and time	15	Caller ID screen messages	26
LCD language.....	16	Wireless mic registration.....	27
Rename base	16	To register a wireless mic.....	27
		To deregister a wireless mic.....	28

Table of contents

Appendix	29
Battery	29
Troubleshooting	30
Maintenance.....	35
FCC, ACTA and IC regulations.....	36
The RBRC[®] seal	37
California Energy Commission battery charging testing instructions	38
For C-UL compliance only	39
Limited warranty	41
Technical specifications	43

Introduction

About ErisStation® Conference Phone with Four Wireless Mics

The ErisStation® Conference Phone with Four Wireless Mics is designed for use in office settings. It consists of a base unit and four wireless mics, enabling participants in different areas of a meeting room to deliver clear conversation in a phone conference.

Parts checklist

Your conference phone contains the following items. Save your sales receipt and original packaging in the event warranty service is necessary.



TIP

Accessories are located under the flap in the package.

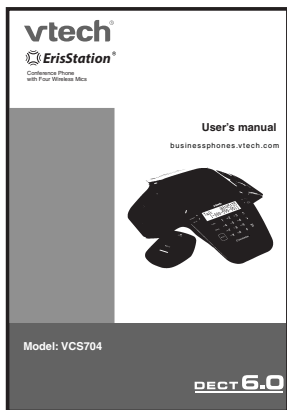

User's manual

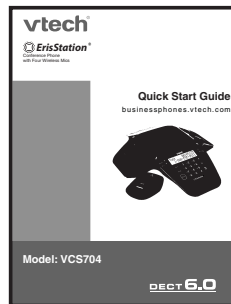

Quick start guide

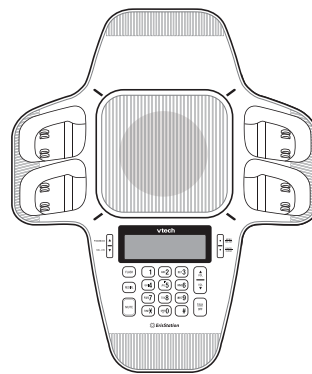

Base unit

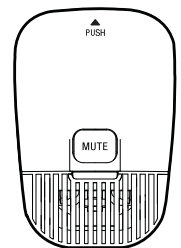

Wireless mic X4

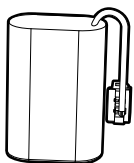

Battery X4

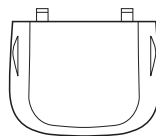

Battery door X4

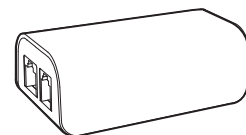

Power adapter

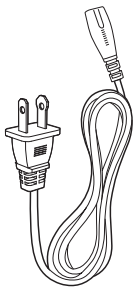

AC power cord

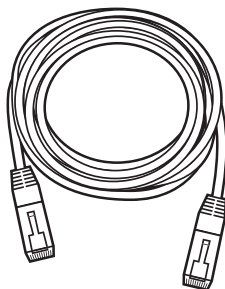

DC power cable

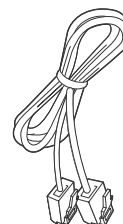

Telephone line cord

note To purchase any accessories or replacements, visit our website at <http://businessphones.vtech.com> or call 1-800-595-9511. In Canada, call 1-800-267-7377.

Getting Started

Connect base unit

Connect the base unit as shown below.

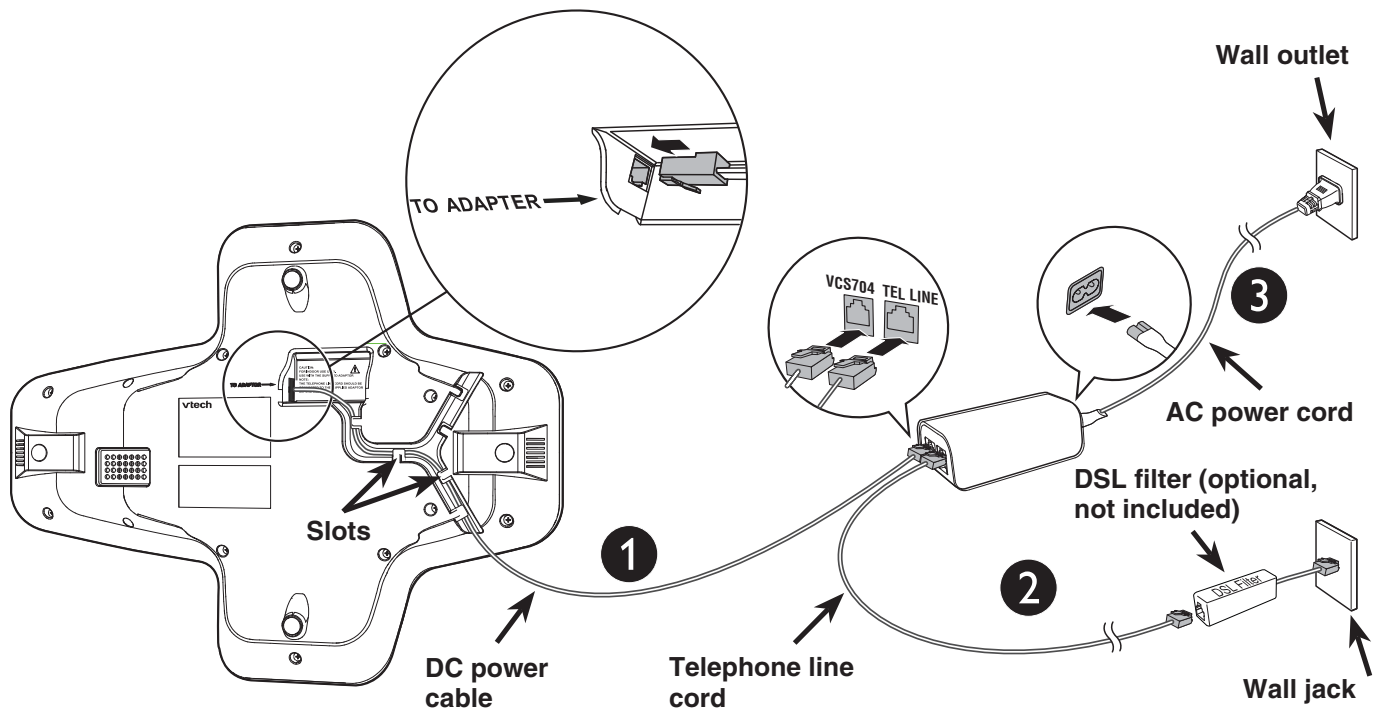

note If the DC power cable is already connected to the base unit and power adapter, skip step 1 and follow steps 2 and 3.

1. Plug one end of the DC power cable into the base unit, and plug the other end into the **VCS704** jack of the power adapter. Route the cord through the slots.
2. Plug one end of the telephone line cord into the **TEL LINE** jack of the power adapter, and plug the other end into a wall jack.
3. Plug the small end of the AC power cord into the power jack of the adapter, and plug the large end into the wall outlet not controlled by a switch.

- note**
- The ErisStation® Conference Phone is not compatible with IP-PBX systems, unless it comes with an analog-line interface with RJ-11 connector. If you already have an IP-PBX system in place, please contact your system provider for a digital-to-analog interface converter.
 - The ErisStation® Conference Phone is not a network device and is not PoE (Power over Ethernet) compatible. It does not require an ethernet network to work. Do not connect it to your ethernet network or directly with any other network devices.
 - The supplied power adapter is designed for use with only the ErisStation® Conference Phone. It is not PoE compatible and is not designed to power any network devices. Do not connect the supplied power adapter to any other network devices through the supplied DC power cable or any other Cat5e ethernet cable.
 - The ErisStation® Conference Phone requires a telephone line to operate.
 - The ErisStation® Conference Phone requires connection to AC power to operate.
 - When the base unit is powered up, the status indicators turn green for about two seconds.
 - If you subscribe to digital subscriber line (DSL) high-speed Internet service through your telephone line, you must install a DSL filter between the telephone line cord and wall jack. Contact your DSL service provider for more information about DSL filter.
 - The AC power cord is intended for a vertical or floor mount position. The prongs are not designed to hold the plug in place if it is plugged into a ceiling or cabinet outlet.

Getting Started

Install battery to the wireless mic

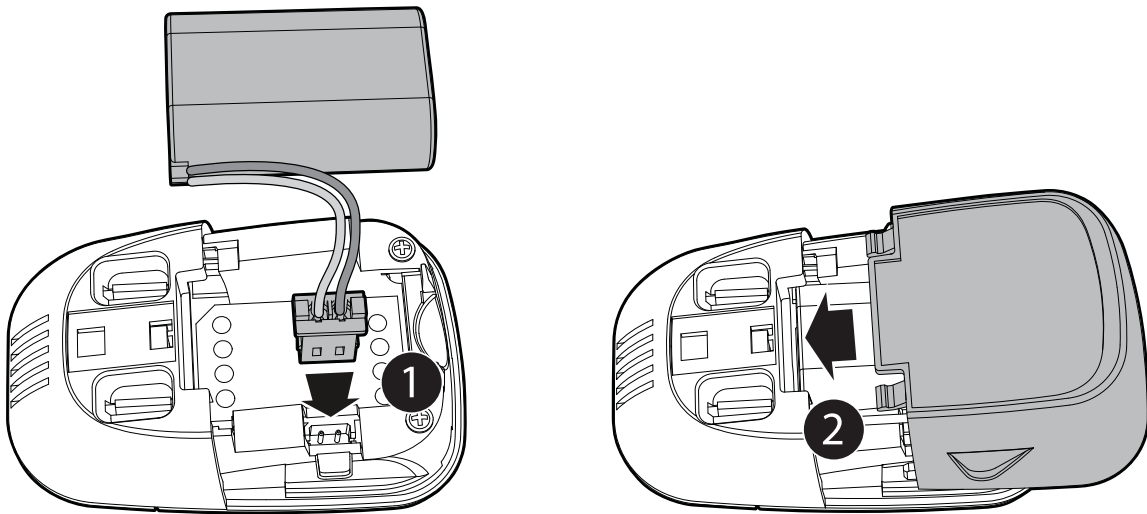

1. Plug the battery connector securely into the socket inside the battery compartment. Insert the battery with the label **THIS SIDE UP** facing up onto the battery compartment.
2. Slide the battery door until it clicks into place.

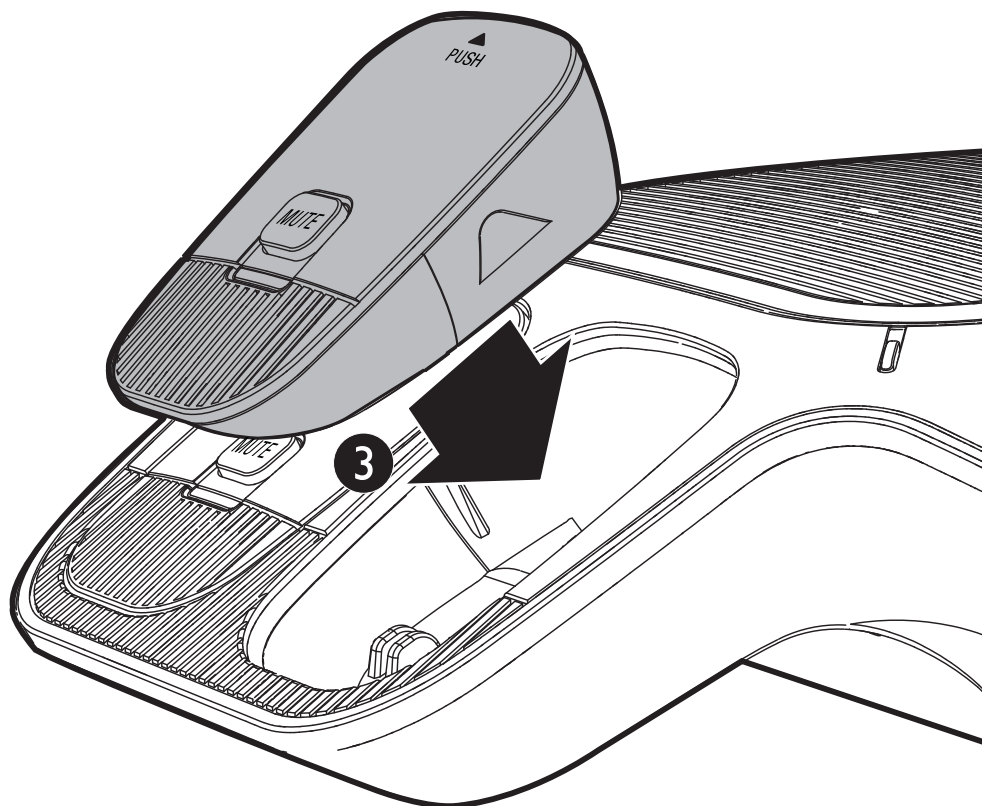

3. Place the wireless mic onto the charging cradle until it is flush.

note The status indicator on the wireless mic turns orange when charging, and turns off when the wireless mic is fully charged.

Getting Started

Before use

Check for dial tone

Lift all the wireless mics from the charging cradles, and then put them on the table. After that, press $\frac{\text{TALK}}{\text{OFF}}$. If you hear a dial tone, and see that the status indicators turn green on both the base unit and the wireless mics, the installation is successful.

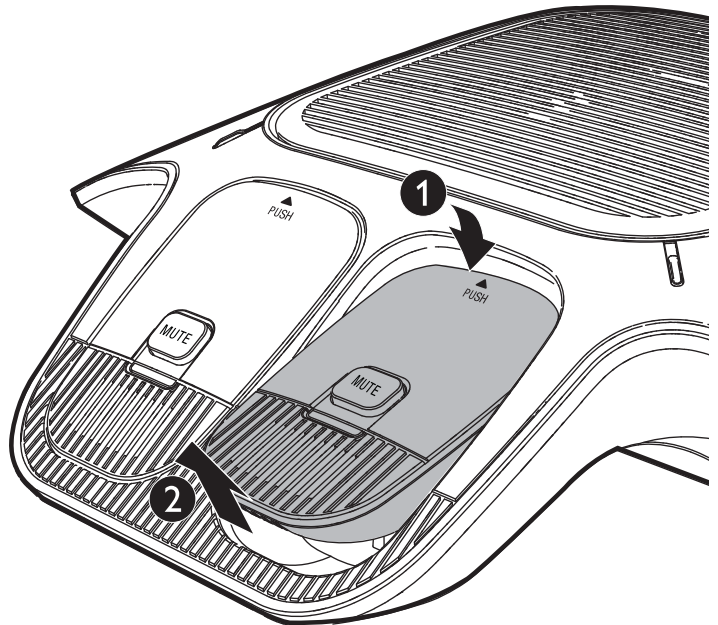

If you do not hear a dial tone:

- Make sure the installation procedures described above are properly done.
- It may be a wiring problem. If you have changed your telephone service to digital service from a cable company or a VoIP service provider, the telephone line may need to be rewired to allow all existing telephone jacks to work. Contact your cable/VoIP service provider for more information.

Operating range

This conference phone operates with the maximum power allowed by the Federal Communications Commission (FCC). Even so, this wireless mic and base unit can communicate over a certain distance, which can vary with the locations of the base unit and wireless mic, the weather, and the layout of your office.

When the wireless mic is out of range, the status indicator flashes red quickly on the wireless mic. The wireless mic will sleep after out of range for 30 minutes. Therefore, you should always return the wireless mic to the charging cradle after use.

If there is an incoming call while the wireless mic is out of range, the incoming call green light may not flash on the wireless mic. If it flashes, the call may not connect well when you press $\frac{\text{TALK}}{\text{OFF}}$ on the base unit. Move the wireless mic closer to the base unit, and then press $\frac{\text{TALK}}{\text{OFF}}$ on the base unit to answer the call. If the wireless mic moves out of range during a telephone conversation, there may be interference. To improve reception, move closer to the base unit.

Getting Started

Base unit overview (front)

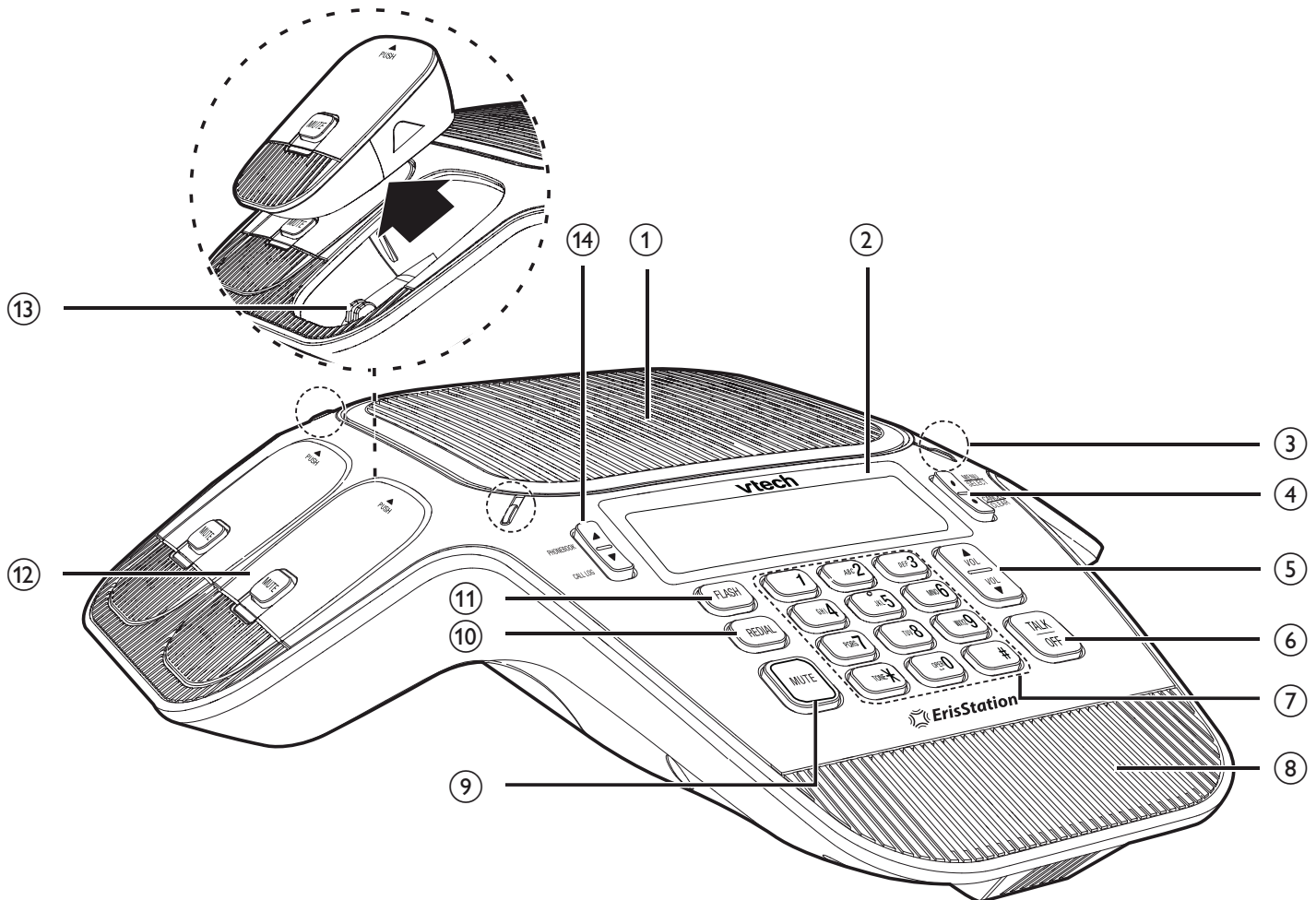

1. Speaker

2. LCD display

3. Status indicator

- Indicates the system status. See also **Status indicators overview** on page 9.

4. MENU SELECT

- Press to show the menu.
- Press to select an item, or save an entry or setting in a menu.

CANCEL CLEAR

- While in a menu, press to return to the previous menu.
- While editing numbers or names, press to delete a character, or press and hold to delete all characters.

Getting Started

5. VOL /

- Press to scroll through the menu, phonebook, or call log.
- Press to adjust the ringer volume.
- During a call, press to adjust the listening volume.

6. OFF

- Press to make, answer, or end a call.

7. Dialing keys

- Press to enter numbers or characters.

0

- While entering numbers, press and hold to insert a dialing pause.
- While editing names, press to add a space.

*

- Press to switch to tone dialing temporarily when using pulse service while on a call.

8. Front microphone

9. MUTE

- During a call, press to mute or end mute all microphones in the system.

10. REDIAL

- Press to redial the last number dialed.

11. FLASH

- During a call, press to answer an incoming call when you receive a call waiting alert.

12. Wireless mic

- See **Wireless mic overview** on page 8.

13. Charging contacts

14. PHONEBOOK ()

- Press to access the phonebook when idle.

CALL LOG ()

- Press to access the call log when idle.

Menu Scroll (/)

- Press to scroll up or down while in the menu, phonebook, or call log.
- While entering names or numbers, press to move the cursor to right or left.

Getting Started

Base unit overview (rear)

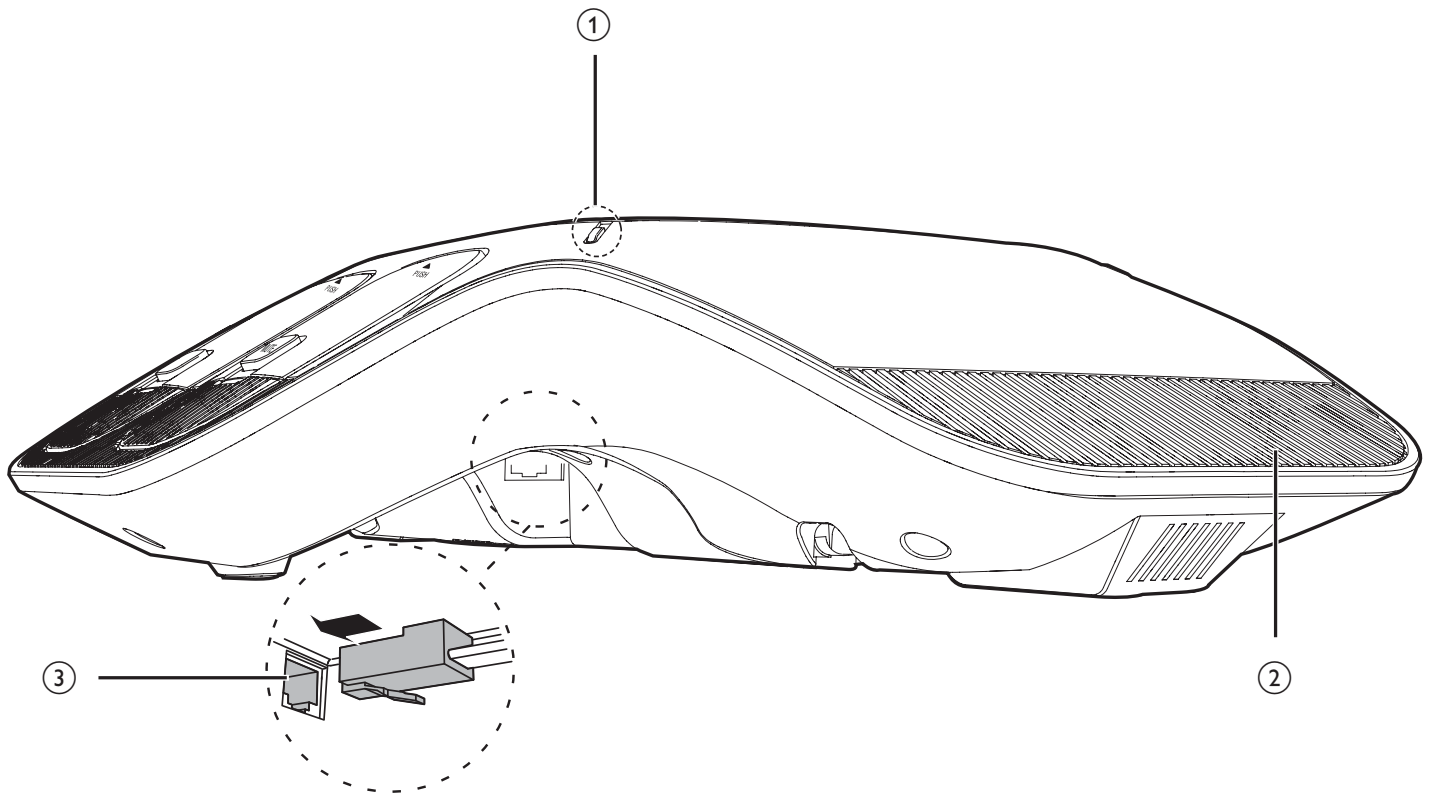

1. Status indicator

- Indicates the system status. See also Status indicators overview on page 9.

2. Rear microphone

3. Adapter jack

Getting Started

Wireless mic overview

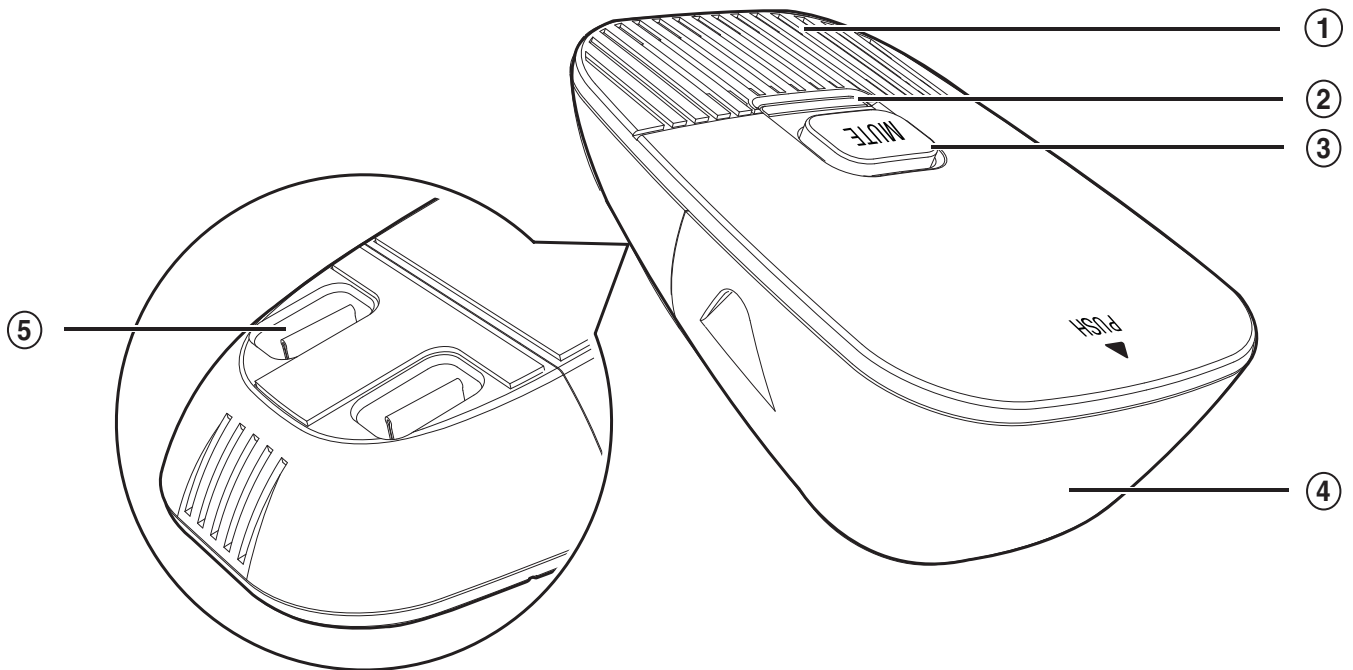

1. Microphone

- Functions as an extended microphone of the base unit during a call

2. Status indicator

- Indicates the system status. See also Status indicators overview on page 9.

3. MUTE

- During a call, press to mute or end mute all microphones in the system.

4. Battery door

5. Charging contacts

Getting Started

Status indicators overview

Status indicator on the base unit

Power up	<ul style="list-style-type: none">• Green for about two seconds.
On a call	<ul style="list-style-type: none">• Green during a call.• Red when the system is muted during a call.
Incoming call	<ul style="list-style-type: none">• Flash green when there is an incoming call.

Status indicator on the wireless mic

Power up	<ul style="list-style-type: none">• Orange for about two seconds.
On the cradle	<ul style="list-style-type: none">• Orange when charging on the cradle except during registration.• Flashes red and green alternately when the non-registered wireless mic is charging on the cradle.
Off the cradle	<ul style="list-style-type: none">• Green during a call.• Red when the system is muted during a call.• Off when the wireless mic is in idle mode or without a battery.• Flashes orange when the wireless mic's battery is low.• Flashes green when there is an incoming call.• Flashes red slowly when the wireless mic is:<ul style="list-style-type: none">• out of range; or• not registered; or• off cradle during paging (with a paging tone).
During registration	<ul style="list-style-type: none">• Flashes red and green alternately.

Conference phone operation

Make a call

1. Press $\frac{\text{TALK}}{\text{OFF}}$ on the base unit.
2. When you hear a dial tone, dial the number with the dialing keys (**0-9**, **TONEX**, or **#**).

note

The screen displays the elapsed time as you talk (in hours, minutes, and seconds).

Use a wireless mic during a call

1. During a call, lift a wireless mic from the base unit charging cradle, and then put it on the table. The status indicator on the wireless mic turns green.
2. Speak towards the microphone on the wireless mic.

note

- For best performance, speak to the microphone on the wireless mic at a distance of no more than 3 feet.
- Always return the wireless mics to the charging cradles after use.

Answer a call

Press $\frac{\text{TALK}}{\text{OFF}}$ on the base unit to answer an incoming call.

End a call

During a call, press $\frac{\text{TALK}}{\text{OFF}}$ on the base unit to end a call.

Redial

Press REDIAL to redial the last number dialed.

Predial a call

1. Enter the telephone number with the dialing keys (**0-9**, **TONEX**, or **#**).
 - Press $\frac{\text{CANCEL}}{\text{CLEAR}}$ to delete one digit.
 - Press and hold $\frac{\text{CANCEL}}{\text{CLEAR}}$ to delete all digits.
 - Press and hold $\frac{\text{OPER}}{\text{0}}$ to insert a dialing pause (a **p** appears).
2. Press $\frac{\text{TALK}}{\text{OFF}}$ to dial.

Volume

During a call, press $\frac{\blacktriangle}{\text{VOL}}$ or $\frac{\blacktriangledown}{\text{VOL}}$ to adjust the listening volume (**1-10**).

note

When the volume reaches the minimum or maximum setting, you hear two beeps.

Conference phone operation

Mute

The mute function allows you to hear the other party but the other party cannot hear you.

- During a call, press **MUTE** on the base unit or a wireless mic. The base unit displays **Muted**. All microphones in the system are muted until the mute function is turned off.
- Press **MUTE** on the base unit or a wireless mic to end mute all microphones in the system. The base unit displays **Microphone ON** briefly.

Temporarily silencing the ringer

When the base unit is ringing, you can temporarily silence the ringer of the base unit without disconnecting the call. The next call rings normally at the preset volume.

To silence the ringer:

- Press **MUTE** on the base unit. The base unit displays **Ringer muted**.

note

- The base unit rings when there is an incoming call unless the ringer volume of the base unit is turned off.
- You can also press \blacktriangle VOL or VOL \blacktriangledown on the base unit to adjust the ringer volume. The adjustment

will be saved and applied to the next incoming call.

3-way conference

note

If your telephone network supports 3-way conference, you can establish a 3-way conference if the two called parties remain on the line.

- If you are using a public switched telephone network (PSTN)* line, contact your telephone service provider to check the subscription status for the 3-way conference feature.
- If you are using a private branch exchange (PBX)** line, contact your PBX system administrator to check the subscription status for the 3-way conference feature.

1. Press $\frac{\text{TALK}}{\text{OFF}}$ on the base unit.
2. When you hear a dial tone, dial the number of the first call.
3. When the first call is connected, press **FLASH** to put the current call on hold.
4. When the dialing tone is heard, enter the new outgoing call number.
5. When the second call is connected, press **FLASH**. A 3-way conference is established.

To end the conference:

- * Public switched telephone network (PSTN) provides traditional landline phone service to residences and many other establishments.
- Press $\frac{\text{TALK}}{\text{OFF}}$ on the base unit.
- ** Private branch exchange (PBX) is a private telephone network used within a company. It allows a single access number to provide several lines to outside callers while providing a range of external lines to internal callers or staff. It relies on computer equipment to perform all the switching of calls, and to make internal calls between extensions within the organizations. It also provides a connection between extensions and external phone lines.

Conference phone operation

Call waiting

When you subscribe to call waiting service from your telephone service provider, you hear an alert beep if someone calls while you are already on a call.

- Press **FLASH** on the base unit to put the current call on hold and take the new call.
- Press **FLASH** on the base unit at any time to switch back and forth between calls.

Clear the redial number

1. Press **MENU**/**SELECT** when the base unit is not in use.
2. Press **▼** or **▲** until the base unit displays **Clear Redial**.
3. Press **MENU**/**SELECT** to confirm. You hear a confirmation tone and the base unit displays **Redial empty**.

Paging

This feature helps you find any misplaced wireless mics within the range of the base unit.

To start the paging tone:

1. Press **MENU**/**SELECT**.
2. Press **▼** or **▲** to scroll to **Find microphone**, and then press **MENU**/**SELECT**. The base unit screen displays **** Paging ****. All wireless mics that are not on the charging cradles play the paging tone for 60 seconds.

To mute the paging tone:

- Press **MUTE** on a wireless mic, or put it back onto the charging cradle.

note When the wireless mic is put back onto the charging cradle, press **CANCEL**/**CLEAR** or **MUTE** on the base unit to stop the paging process.

To stop paging:

- Press **CANCEL**/**CLEAR** or **MUTE** on the base unit.

note An incoming call stops the paging process.

Conference phone operation

Chain dialing

Use this feature to initiate a dialing sequence from numbers stored in the phonebook, call log, or the last number dialed while you are on a call using the base unit.

Chain dialing can be particularly useful when you are required to enter a PIN code to access a conference call. You can save the PIN code to the phonebook and retrieve it from your phonebook entries during a call.

To access a number from the phonebook while on a call:

1. Press **MENU**/**SELECT**, and then ▼ or ▲ to scroll to **Phonebook**. Press **MENU**/**SELECT**.

-OR-

Press **PHONEBOOK** (▲) to access the phonebook.

2. Press ▼ or ▲ to scroll to the desired entry.

3. Press **MENU**/**SELECT** to dial the displayed number.

To access a number from the call log while on a call:

1. Press **MENU**/**SELECT**, and then press ▼ or ▲ to scroll to **Call log**. Press **MENU**/**SELECT**.

-OR-

Press **CALL LOG** (▼) to access the call log.

2. Press ▼ or ▲ to scroll to the desired entry.

3. Press **MENU**/**SELECT** twice to dial the displayed number.

To access a number from the last number dialed while on a call:

1. Press **REDIAL** to redial the last number dialed.

note

Press **CANCEL**/**CLEAR** to exit the phonebook or call log when you are on a call.

Settings

Using the Menu

You can enter the menu to change the settings.

In the ringers menu, you can adjust the ringer volume and select the ringer tones for incoming calls.

In the settings menu, you can change the settings for the date and time, LCD language, base name, key tone, dial mode, area code, and loop gain. You can also reset the base unit to default settings.

To enter the menu:

1. Press $\frac{\text{MENU}}{\text{SELECT}}$ when the base unit is not in use.
2. Press \blacktriangledown or \blacktriangle until the base unit displays the desired feature menu.
3. Press $\frac{\text{MENU}}{\text{SELECT}}$ to enter that menu.
- To return to the previous menu, press $\frac{\text{CANCEL}}{\text{CLEAR}}$.

Ringer volume

You can adjust the ringer volume or turn the ringer off on the base unit.

1. Press \blacktriangledown or \blacktriangle to sample each ringer volume level (**Ringer off**, or **1** to **6**) when the base unit is not in use.
2. Press $\frac{\text{MENU}}{\text{SELECT}}$ to save your selection. You hear a confirmation tone.

-OR-

1. Press $\frac{\text{MENU}}{\text{SELECT}}$ when the base unit is not in use.
2. Press \blacktriangledown or \blacktriangle until the base unit displays **Ringers**, and then press $\frac{\text{MENU}}{\text{SELECT}}$.
3. The base unit displays **Ringer volume**. Press $\frac{\text{MENU}}{\text{SELECT}}$ again.
4. Press \blacktriangledown or \blacktriangle to sample each ringer volume level (**Ringer off**, or **1** to **6**).
5. Press $\frac{\text{MENU}}{\text{SELECT}}$ to save your selection. You hear a confirmation tone.

note

If you turn off the ringer volume, the screen will display **Ringer off**. When the ringer volume is off, the base unit is silenced for all incoming calls.

Settings

Ringer tone

You can choose from different ringer tones on the base unit.

1. Press **MENU SELECT** when the base unit is not in use.
2. Press **▼** or **▲** until the base unit displays **Ringers**, and then press **MENU SELECT**.
3. Press **▼** to highlight **Ringer tone**, and then press **MENU SELECT**.
4. The base unit displays **RINGER TONE** with the current setting. Press **▼** or **▲** to sample each ringer tone (**Tone 1** to **Tone 10**).
5. Press **MENU SELECT** to save your selection. You hear a confirmation tone.

note If you turn off the ringer volume, you will not hear ringer tone samples.

Set date and time

Before using the ErisStation® Conference Phone, set the date and time as follows. The date and time will be displayed on the base unit when idle. If you subscribe to caller ID service, the day, month, and time are set automatically with each incoming call. However, the year must be correct so that the day of the week can be calculated from the call log information.

1. Press **MENU SELECT** when the base unit is not in use.
2. Press **▼** or **▲** until the base unit displays **Set date/time**, and then press **MENU SELECT**.
3. Press **▼** or **▲** to select the month, and then press **MENU SELECT**, or use the dialing keys to enter a two-digit number (**01-12**).
4. Press **▼** or **▲** to select the date, and then press **MENU SELECT**, or use the dialing keys to enter a two-digit number (**01-31**).
5. Press **▼** or **▲** to select the year, and then press **MENU SELECT**, or use the dialing keys to enter a two-digit number (**00-99**), and then press **MENU SELECT**.
6. Press **▼** or **▲** to select the hour, and then press **MENU SELECT**, or use the dialing keys to enter a two-digit number (**01-12**).
7. Press **▼** or **▲** to select the minute, and then press **MENU SELECT**, or use the dialing keys to enter a two-digit number (**00-59**).
8. Press **▼** or **▲** to select **AM** or **PM**.
9. Press **MENU SELECT** to save the settings. You hear a confirmation tone.

note The base unit beeps twice if you enter an invalid number.

Settings

LCD language

You can select English, French, or Spanish to be used in the base unit screen display.

1. Press **MENU**/**SELECT** when the base unit is not in use.
2. Press **▼** or **▲** until the base unit displays **Settings**, and then press **MENU**/**SELECT**.
3. Press **MENU**/**SELECT** to choose **LCD language**.
4. Press **▼** or **▲** to choose **English**, **Français**, or **Español**, and then press **MENU**/**SELECT**.
5. Press **MENU**/**SELECT** again to save your selection. You hear a confirmation tone.

note If you accidentally changed the LCD language to French or Spanish, you can reset it to English easily by pressing **MENU**/**SELECT**, and then entering **TONEX364#**.

Rename base

You can create a new name (up to 16 characters) for the base unit. The default name is **ErisStation**.

1. Press **MENU**/**SELECT** when the base unit is not in use.
2. Press **▼** or **▲** until the base unit displays **Settings**, and then press **MENU**/**SELECT**.
3. Press **▼** or **▲** until the base unit displays **Rename base**, and then press **MENU**/**SELECT**.
4. The base unit displays the default name **ErisStation**. Use the dialing keys to edit the name.
 - Press **▼** or **▲** to move the cursor to the left or right.
 - Press **CANCEL**/**CLEAR** to erase a character.
 - Press and hold **CANCEL**/**CLEAR** to erase all characters.
 - Press **TONEX** to change the next letter to upper or lower case.
5. Press **MENU**/**SELECT** to save the name. You hear a confirmation tone.

Settings

Key tone

You can turn the key tone on or off for the base unit. If the key tone is on, the base unit beeps with each key press. If the key tone is off, there are no beeps when you press the keys.

1. Press **MENU**/**SELECT** when the base unit is not in use.
2. Press ▼ or ▲ until the base unit displays **Settings**, and then press **MENU**/**SELECT**.
3. Press ▼ or ▲ until the base unit displays **Key tone**, and then press **MENU**/**SELECT**.
4. The base unit displays **KEY TONE** with the current setting.
Press ▼ or ▲ to sample each key tone (**Off**, or **1** to **3**).
5. Press **MENU**/**SELECT** to save your selection. You hear a confirmation tone.

Dial mode

The dial mode is preset to tone dialing. If you have pulse (rotary) service, you must change the dial mode to pulse dialing before using the base unit to make a call.

1. Press **MENU**/**SELECT** when the base unit is not in use.
2. Press ▼ or ▲ until the base unit displays **Settings**, and then press **MENU**/**SELECT**.
3. Press ▼ or ▲ until the base unit displays **Dial mode**, and then press **MENU**/**SELECT**.
4. Press ▼ or ▲ to choose **Touch-tone** or **Pulse**.
5. Press **MENU**/**SELECT** to save your selection. You hear a confirmation tone.

note You can press **TO****NEX** to switch to tone dialing temporarily when using pulse service while on a call.

Area code

If you dial local calls using only seven digits (area code not required), you can program your home area code so that when you receive a call within your local area, the telephone number is automatically stored in the call log without the area code.

1. Press **MENU**/**SELECT** when the base unit is not in use.
2. Press ▼ or ▲ until the base unit displays **Settings**, and then press **MENU**/**SELECT**.
3. Press ▼ or ▲ until the base unit displays **Area code**, and then press **MENU**/**SELECT**. The base unit briefly displays **Only for 7digit dial from CID**, followed by **AREA CODE**:
4. Use the dialing keys to enter the 3-digit area code.
 - Press ▼ or ▲ to move the cursor to the left or right.
 - Press **CANCEL**/**CLEAR** to erase a digit.
 - Press and hold **CANCEL**/**CLEAR** to erase all digits.
5. Press **MENU**/**SELECT** to save your selection. You hear a confirmation tone.

Settings

Loop gain

The default settings of the loop gain feature is **Off**. Turn this feature on only when the callers cannot hear you well, and you are using a public switched telephone network (PSTN) line.

1. Press **MENU SELECT** when the base unit is not in use.
2. Press ▼ or ▲ until the base unit displays **Settings**, and then press **MENU SELECT**.
3. Press ▼ or ▲ until the base unit displays **Loop gain**, and then press **MENU SELECT**.
4. Press ▼ or ▲ to choose **On** or **Off**.
5. Press **MENU SELECT** to save your selection. You hear a confirmation tone.

note Turn the loop gain feature back to **Off** if the callers cannot observe any improvement or are experiencing any new audio issues like echo or dropout.

Reset

You can reset the base unit to the default settings. Once the base unit is reset, all your customized settings, call log entries, and redial entry will be deleted. All the phonebook records and speed dial entries will remain. The default settings are listed below.

Feature	Default Value
Call log	Empty
Listening volume	Volume 6
Ringer volume	Volume 4
Ringer tone	Tone 1
Date and time	Empty
LCD language	English
Base name	ErisStation
Key tone level	Level 2
Dial mode	Touch-tone
Area code	Empty
Loop gain	Off

1. Press **MENU SELECT** when the base unit is not in use.
2. Press ▼ or ▲ until the base unit displays **Settings**, and then press **MENU SELECT**.
3. Press ▼ or ▲ until the base unit displays **Reset**, and then press **MENU SELECT**.
4. The base unit displays **Reset to default?** Press **MENU SELECT**. The settings are reset to the default values and the screen returns to idle.

Phonebook

About the phonebook

The phonebook can store up to 50 entries with up to 30 digits for each phone number and 15 characters for each name.

- When you access the phonebook without an entry, the base unit displays **Phonebook empty**.
- When the phonebook is full and you try to save an entry, the base unit displays **Phonebook full**.
- When you try to add an entry already stored in the phonebook, the base unit displays **Number already saved**.

Add a phonebook entry

1. Press $\frac{\text{MENU}}{\text{SELECT}}$ when the base unit is not in use.
2. Press \blacktriangledown or \blacktriangle to scroll to **Phonebook**, and then press $\frac{\text{MENU}}{\text{SELECT}}$.
3. Press \blacktriangledown or \blacktriangle to scroll to **Add contact**, and then press $\frac{\text{MENU}}{\text{SELECT}}$.
4. When **ENTER NUMBER** displays, use the dialing keys to enter a number (up to 30 digits).
 - Press \blacktriangledown or \blacktriangle to move the cursor to the left or right.
 - Press and hold $\overset{\text{OPER}}{\text{0}}$ to insert a dialing pause (a **p** appears).
 - Press $\frac{\text{CANCEL}}{\text{CLEAR}}$ to erase a digit.
 - Press and hold $\frac{\text{CANCEL}}{\text{CLEAR}}$ to erase all digits.
5. Press $\frac{\text{MENU}}{\text{SELECT}}$ to move on to the name.
6. When **ENTER NAME** displays, use the dialing keys to enter a name (up to 15 characters).
 - Press \blacktriangledown or \blacktriangle to move the cursor to the left or right.
 - Press $\overset{\text{OPER}}{\text{0}}$ to add a space.
 - Press $\frac{\text{CANCEL}}{\text{CLEAR}}$ to erase a character.
 - Press and hold $\frac{\text{CANCEL}}{\text{CLEAR}}$ to erase all characters.
 - Press $\overset{\text{TONE}}{\text{X}}$ to change the next letter to upper or lower case.
7. Press $\frac{\text{MENU}}{\text{SELECT}}$ to save. The base unit displays **Saved**, and then returns to the previous menu. You hear a confirmation tone.

note

- Each time you press a key, the character on that key appears. Additional key presses produce other characters on that key. Press the key repeatedly until the desired character appears. The first character of every word is capitalized.
- If you are using a private branch exchange (PBX) line and want to add an external number to the phonebook, make sure the dialing prefix (usually **9**), followed by a dialing pause (press and hold $\overset{\text{OPER}}{\text{0}}$ and a **p** appears), are inserted before the external number.

Phonebook

Review phonebook entries

Phonebook entries displays in alphabetical order.

1. Press **PHONEBOOK** (▲) when the base unit is not in use. The base unit displays the first entry in the phonebook.
2. Press ▼ or ▲ to browse through the phonebook.

-OR-

1. Press $\frac{\text{MENU}}{\text{SELECT}}$ when the base unit is not in use.
2. Press ▼ or ▲ to scroll to **Phonebook**, and then press $\frac{\text{MENU}}{\text{SELECT}}$.
3. Press ▼ or ▲ to scroll to **Review**, and then press $\frac{\text{MENU}}{\text{SELECT}}$.
4. Press ▼ or ▲ to browse through the phonebook.

note

When the phonebook is empty, the base unit displays **Phonebook empty**.

Alphabetical search

You can perform an alphabetical search on the base unit.

1. Press **PHONEBOOK** (▲) when the base unit is not in use.

-OR-

- i. Press $\frac{\text{MENU}}{\text{SELECT}}$ when the base unit is not in use.
 - ii. Press ▼ or ▲ to scroll to **Phonebook**, and then press $\frac{\text{MENU}}{\text{SELECT}}$ twice.
2. Use the dialing keys to enter the initial character of the name.
 - For example: The phonebook entries are in the order of Ava, Ethan, Jennifer, Jessie, Kevin, Linda, and Matt. Press **5 (JKL)** to search and to alphabetically sort out the names with the initial character falls under J, K, and L. They are **Jennifer**, **Jessie**, **Kevin**, and **Linda** in this case. The name **Jennifer** displays first. With each press on ▼, the display shows the next sorted name. If you continue pressing ▼ after the last sorted name, the phonebook returns to its first phonebook entry, that is **Ava**.
 - If there is no entry that matches your search, the next closest entry or the last entry in the phonebook displays on the screen. If necessary, press ▼ or ▲ to browse.

Dial a phonebook entry

Search for the desired entry in the phonebook (see **Review phonebook entries** or **Alphabetical search** above).

To dial the displayed entry on the base unit, press $\frac{\text{TALK}}{\text{OFF}}$.

Phonebook

Edit a phonebook entry

1. Search for the desired entry in the phonebook (see **Review phonebook entries** or **Alphabetical search** on page 20).
2. When the desired entry displays, press $\frac{\text{MENU}}{\text{SELECT}}$.
3. Press $\frac{\text{MENU}}{\text{SELECT}}$ again to choose **Edit contact**.
4. The base unit displays **EDIT NUMBER**. Use the dialing keys to edit the number.
 - Press ▼ or ▲ to move the cursor to the left or right.
 - Press and hold $\frac{\text{OPER}}{\text{0}}$ to insert a dialing pause (a **p** appears).
 - Press $\frac{\text{CANCEL}}{\text{CLEAR}}$ to erase a digit.
 - Press and hold $\frac{\text{CANCEL}}{\text{CLEAR}}$ to erase all digits.
5. Press $\frac{\text{MENU}}{\text{SELECT}}$ to save the number and move on to the name. Use the dialing keys to edit the name.
 - Press ▼ or ▲ to move the cursor to the left or right.
 - Press $\frac{\text{OPER}}{\text{0}}$ to add a space.
 - Press $\frac{\text{CANCEL}}{\text{CLEAR}}$ to erase a character.
 - Press and hold $\frac{\text{CANCEL}}{\text{CLEAR}}$ to erase all characters.
 - Press $\frac{\text{TONE}}{\text{X}}$ to change the next letter to upper or lower case.
6. Press $\frac{\text{MENU}}{\text{SELECT}}$ to save the entry. The base unit displays **Saved**, and then the revised entry. You hear a confirmation tone.

Delete a phonebook entry

1. Search for the desired entry in the phonebook (see **Review phonebook entries** or **Alphabetical search** on page 20).
2. When the desired entry displays, press $\frac{\text{MENU}}{\text{SELECT}}$.
3. Press ▼ or ▲ to scroll to **Delete**, and then press $\frac{\text{MENU}}{\text{SELECT}}$. The base unit displays **Delete contact?**
4. Press $\frac{\text{MENU}}{\text{SELECT}}$ to confirm. The base unit displays **Contact deleted**, and then returns to the phonebook list. You hear a confirmation tone.

Phonebook

Delete all phonebook entries

1. Press $\frac{\text{MENU}}{\text{SELECT}}$ when the base unit is not in use.
2. Press \blacktriangledown or \blacktriangle to scroll to **Phonebook**, and then press $\frac{\text{MENU}}{\text{SELECT}}$.
3. Press \blacktriangledown or \blacktriangle to scroll to **Delete all**, and then press $\frac{\text{MENU}}{\text{SELECT}}$. The base unit displays **Delete all contacts?**
4. Press $\frac{\text{MENU}}{\text{SELECT}}$ to confirm. The base unit displays **All contacts deleted**, and then returns to idle. You hear a confirmation tone.

Speed dial

You can copy up to 10 of your phonebook entries to the speed dial locations (**0** and **1-9**). The base unit displays up to 12 characters for a speed dial entry.

Assign a speed dial entry

1. Press $\frac{\text{MENU}}{\text{SELECT}}$ when the base unit is not in use.
2. Press \blacktriangledown or \blacktriangle to scroll to **Phonebook**, and then press $\frac{\text{MENU}}{\text{SELECT}}$.
3. Press \blacktriangledown or \blacktriangle to scroll to **Speed dial**, and then press $\frac{\text{MENU}}{\text{SELECT}}$.
4. Press \blacktriangledown , \blacktriangle , or a dialing key (**0** or **1-9**) to choose the desired empty speed dial location.
5. Press $\frac{\text{MENU}}{\text{SELECT}}$ to show the phonebook. The base unit displays **Copy from phonebook**, and then the first phonebook entry.
6. Press \blacktriangledown or \blacktriangle to scroll to the desired entry.
-OR-
Use the alphabetical search to find the desired entry (see page 20).
7. Press $\frac{\text{MENU}}{\text{SELECT}}$ to save. You hear a confirmation tone. The name (up to 12 characters) appears in the selected speed dial location.

Phonebook

Reassign a speed dial entry

1. Press $\frac{\text{MENU}}{\text{SELECT}}$ when the base unit is not in use.
2. Press \blacktriangledown or \blacktriangle to scroll to **Phonebook**, and then press $\frac{\text{MENU}}{\text{SELECT}}$.
3. Press \blacktriangledown or \blacktriangle to scroll to **Speed dial**, and then press $\frac{\text{MENU}}{\text{SELECT}}$.
4. Press \blacktriangledown , \blacktriangle , or a dialing key (**0** or **1-9**) to choose an occupied speed dial location, and then press $\frac{\text{MENU}}{\text{SELECT}}$ twice.
5. Press $\frac{\text{MENU}}{\text{SELECT}}$ to choose **Change Sp dial**. The base unit displays **Copy from Phonebook**, and then the first phonebook entry.
6. Press \blacktriangledown or \blacktriangle to scroll to the desired entry for replacement.

-OR-

Use the alphabetical search to find the desired entry (see page 20).

7. Press $\frac{\text{MENU}}{\text{SELECT}}$ to save. You hear a confirmation tone. The new name (up to 12 characters) appears in the selected speed dial location.

Dial a speed dial number

- When the base unit is not in use, press and hold a dialing key (**0** or **1-9**) to dial the number stored in the corresponding location.

note When the speed dial location is empty, the screen displays the speed dial list. See **Assign a speed dial entry** on page 22 to add a new entry.

Delete a speed dial entry

1. Press $\frac{\text{MENU}}{\text{SELECT}}$ when the base unit is not in use.
2. Press \blacktriangledown or \blacktriangle to scroll to **Phonebook**, and then press $\frac{\text{MENU}}{\text{SELECT}}$.
3. Press \blacktriangledown or \blacktriangle to scroll to **Speed dial**, and then press $\frac{\text{MENU}}{\text{SELECT}}$.
4. Press \blacktriangledown , \blacktriangle , or a dialing key (**0** or **1-9**) to choose the desired speed dial location, and then press $\frac{\text{MENU}}{\text{SELECT}}$ twice.
5. Press \blacktriangledown or \blacktriangle to scroll to **Clear Sp dial**, and then press $\frac{\text{MENU}}{\text{SELECT}}$. The base unit displays **Speed dial empty** and returns to the speed dial list.

Call log

About caller ID

This product supports caller ID services offered by most telephone service providers. Depending on your service subscription, you may see the caller's number, or the caller's name and number after the first or second ring. Caller ID allows you to see the name, number, date and time of calls.

Call log

If you subscribe to caller ID service, information about each caller will appear after the first or second ring. If you answer a call before the caller's information appears, it will not be saved in the call log.

- The call log stores up to 50 entries. Each entry has up to 16 digits for the phone number and 15 characters for the name. If the phone number has more than 16 digits, only the last 16 digits appear. If the name has more than 15 characters, only the first 15 characters are shown and saved in the call log. The time and date of a call log entry are shown together with the name or number.
- You can review an entry, dial an entry, or copy an entry into the phonebook.
- Entries are stored in reverse chronological order.
- When the call log is full, the oldest entry is deleted to make room for new incoming call information.
- Call log empty shows when you access the call log without records.

Missed call indicator

When there are calls that have not been answered, the screens display **XX Missed calls**. Whenever you enter the call log, or the base unit resumes power after power outage, the missed call indicator goes away.

Call log

Review the call log

Review the call log to find out who called, to return the call, or to copy the caller's name and number into your phonebook.

1. Press **CALL LOG** (▼) when the base unit is not in use.
2. Press ▼ or ▲ to browse through the call log.

-OR-

1. Press $\frac{\text{MENU}}{\text{SELECT}}$ when the base unit is not in use.
2. Press ▼ or ▲ to scroll to **Call log**, and then press $\frac{\text{MENU}}{\text{SELECT}}$.
3. Press $\frac{\text{MENU}}{\text{SELECT}}$ to choose **Review**.
4. Press ▼ or ▲ to browse through the call log.

note

When the call log is empty, the base unit displays **Call log empty**.

Save a call log entry to phonebook

1. Search for the desired call log entry (see **Review the Call log** above).
2. When the desired entry displays, press $\frac{\text{MENU}}{\text{SELECT}}$ twice.
3. Press $\frac{\text{MENU}}{\text{SELECT}}$ to choose **Store to PB**. The base unit displays **EDIT NUMBER**.
4. Use the dialing keys to edit the number.
 - Press ▼ or ▲ to move the cursor to the left or right.
 - Press and hold $\frac{\text{OPER}}{\text{0}}$ to insert a dialing pause (a **p** appears).
 - Press $\frac{\text{CANCEL}}{\text{CLEAR}}$ to erase a digit.
 - Press and hold $\frac{\text{CANCEL}}{\text{CLEAR}}$ to erase all digits.
5. Press $\frac{\text{MENU}}{\text{SELECT}}$. The base unit displays **EDIT NAME**. Use the dialing keys to edit the name.
 - Press ▼ or ▲ to move the cursor to the left or right.
 - Press $\frac{\text{OPER}}{\text{0}}$ to add a space.
 - Press $\frac{\text{CANCEL}}{\text{CLEAR}}$ to erase a character.
 - Press and hold $\frac{\text{CANCEL}}{\text{CLEAR}}$ to erase all characters.
 - Press $\frac{\text{TONE}}{\text{X}}$ to change the next letter to upper or lower case.
6. Press $\frac{\text{MENU}}{\text{SELECT}}$ to save the entry. The base unit displays **Saved** and returns to the call log.

Call log

Dial a call log entry

1. Search for the desired call log entry (see **Review the Call log** on page 25).
2. When the desired entry displays, press $\frac{\text{TALK}}{\text{OFF}}$ on the base unit to dial.

Delete a call log entry

1. Search for the desired call log entry (see **Review the Call log** on page 25).
2. When the desired entry displays, press $\frac{\text{MENU}}{\text{SELECT}}$ twice.
3. Press \blacktriangledown or \blacktriangle to scroll to **Delete**, and then press $\frac{\text{MENU}}{\text{SELECT}}$. The base unit displays **Deleted** and returns to the main menu. You hear a confirmation tone.

Delete all call log entries

1. Press $\frac{\text{MENU}}{\text{SELECT}}$ when the base unit is not in use.
2. Press \blacktriangledown or \blacktriangle until the base unit displays **Call log**, and then press $\frac{\text{MENU}}{\text{SELECT}}$.
3. Press \blacktriangledown or \blacktriangle to scroll to **Del all calls**, and then press $\frac{\text{MENU}}{\text{SELECT}}$. The base unit displays **Delete all calls?**
4. Press $\frac{\text{MENU}}{\text{SELECT}}$. The base unit displays **Deleted** and returns to the main menu. You hear a confirmation tone.

Caller ID screen messages

Displays	When:
PRIVATE NUMBER	The caller is blocking the number.
PRIVATE CALLER	The caller is blocking the name and number.
UNKNOWN NUMBER	This caller's number is unavailable.
UNKNOWN CALLER	No information is provided about this caller.
L	This is a long distance call.

Wireless mic registration

Your wireless mics are pre-registered. If for some reason, you want to purchase replacement wireless mics (**VCS704 WM**), visit our website at <http://businessphones.vtech.com> or call **1-800-595-9511**. In Canada, call **1-800-267-7377**. You should register your new wireless mics to the base unit following the instructions below.

To register a wireless mic

As part of this process, all existing, broken, or lost wireless mics will be deregistered first. Then, the base unit will re-register the four wireless mics that are placed onto the charging cradles.

Before registration, unplug the telephone line cord from the wall jack to make sure there are no incoming calls during registration.

1. Gather the four wireless mics that are to be registered and place them onto the charging cradles. Registration has not yet started.
2. Enter ^{TO} **X331734#** when the base unit is not in use, and then press ^{MENU} **SELECT**. The screen displays **Please place all wireless mics on cradle, then press 'SELECT'**.
3. Make sure all the four wireless mics are on the charging cradles, and then press ^{MENU} **SELECT**. The wireless mics enter the deregistration mode, and the screen displays **Processing...**

After deregistration is complete, registration starts. The screen displays **Registering... 1 2 3 4**. The number **X** blinks while registering the X-th wireless mic. You hear a confirmation tone when each wireless mic is registered. When all the four wireless mics are registered, the base unit displays **Registration done**.

After registration, plug the telephone line cord back into the wall jack.

note

- If registration has failed, the base unit will display **Registration failed. Try again** and returns to idle. You hear an error tone. Remove the wireless mics from the charging cradles and place them back in. Repeat steps 1 to 3 to try the entire registration process again.
- If the screen does not display Registration done after step 3, repeat steps 1 to 3 to try the entire registration process again.
- All wireless mics should always be kept on the charging cradles during the whole registration process. Any wireless mic that is registered before but not put onto the charging cradle will be deregistered after the above operations.
- Status indicators on the wireless mics flash red and green alternately during registration.
- To cancel registration, press ^{CANCEL} **CLEAR**. The base unit displays **Registration cancelled**. If registration is cancelled, some of the wireless mics may be deregistered. To register them back to the base unit, repeat steps 1 to 3 to try the entire registration process again.

Wireless mic registration

To deregister a wireless mic

You may also deregister manually a wireless mic that you not going to use for some time.

1. Remove battery from the wireless mic, and then press and hold **MUTE** on the wireless mic.
2. While you press and hold **MUTE**, insert battery back into the wireless mic (see page 3).
3. After about 10 seconds, when the status indicator on the wireless mic turns red, release **MUTE**, and then press it again within 1 second. The status indicator turns off, and then it turns back on. It changes from orange to red, and then it flashes red slowly. The wireless mic is now deregistered.

note

- If deregistration fails, repeat Step 1 through Step 3 above.
- The wireless mic will function as normal if you fail to press **MUTE** within 1 second in Step 3.
- To register the wireless mic to the base unit again, follow the registration instructions on the previous page.

Appendix

Battery

It takes up to 8 hours for the wireless mic battery to be fully charged (the orange status indicator turns off). Always return the wireless mics to the charging cradles after use. When it is fully charged, you can expect the following operating times:

Operation	Operating time
While the wireless mic is in use (talking*)	Up to 8 hours
While not in use (standby**)	Up to 70 hours

* Operating times vary depending on your actual use and the lifespan of the battery.

** The wireless mic is not charging or in use.

The battery needs charging when:

- A new battery is installed into the wireless mic.
- The status indicator on the wireless mic flashes orange.

CAUTION:

To reduce the risk of fire or injury, read and follow these instructions:

- Use only the batteries provided or equivalent. To order a replacement, visit our website at <http://businessphones.vtech.com> or call 1-800-595-9511. In Canada, call 1-800-267-7377.
- Do not dispose of the batteries in a fire. Check with local waste management codes for special disposal instructions.
- Do not open or mutilate the batteries. Released electrolyte is corrosive and may cause burns or injury to the eyes or skin. The electrolyte may be toxic if swallowed.
- Exercise care in handling batteries in order not to create a short circuit with conductive materials.
- Charge the batteries provided with or identified for use with this product only in accordance with the instructions and limitations specified in this manual.
- Observe proper polarity orientation between the battery and metallic contacts.
- To prevent fire or shock hazard, do not expose this product to water or any type of moisture.

Troubleshooting

If you have difficulty with your conference phone, please try the suggestions below. For customer service, visit our website at <http://businessphones.vtech.com> or call **1-800-595-9511**. In Canada, call **1-800-267-7377**.

My ErisStation® Conference Phone does not work at all.

After powering up the base unit with a correct setup (page 2), the LCD display will show the default name of the base, “**ErisStation**”. Press $\frac{\text{TALK}}{\text{OFF}}$ and you will hear a dial tone. If any of this does not happen, please try the following:

- Make sure the DC power cable is securely plugged into base unit and the power adapter.
- Make sure the telephone line cord is plugged firmly into the power adapter and the wall jack.
- Make sure the AC power cord is securely plugged into the power adapter and a wall outlet not controlled by a wall switch.

The LCD display shows No line. I cannot hear the dial tone.

Disconnect the telephone line cord from the power adapter and plug it into a working telephone. If the other telephone does not work, the problem is probably in the telephone line cord. Try replacing the telephone line cord.

If the line cord has been replaced and both the ErisStation® Conference Phone and the other telephone do not work, the problem is in the wall jack, wiring, or telephone/PBX service.

- If you are using a public switched telephone network (PSTN) line, contact your telephone service provider (charges may apply).
- If you are using a private branch exchange (PBX) extension line, contact your PBX system administrator.
- If you have changed your telephone service to digital service from a cable company or a VoIP service provider, the telephone line may need to be rewired to allow all existing telephone jacks to work. Contact your telephone service provider (charges may apply).

I cannot dial out.

- Try all the above suggestions.
- Make sure there is a dial tone before dialing.
- If other telephones in your office are having the same problem, the problem is in the wiring or telephone service. Contact your telephone service provider (charges may apply) or PBX system administrator.
- Eliminate any background noise. Dial from another room in your office with less background noise.
- If you have changed your telephone service to digital service from a cable company or a VoIP service provider, the telephone line may need to be rewired to allow all existing telephone jacks to work. Contact your telephone service provider (charges may apply).
- If you are using a PBX line and want to dial an external number, make sure the dialing prefix (usually **9**), followed by a dialing pause (press and hold $\frac{\text{OPER}}{\text{0}}$ and a **p** appears), are inserted before the external number.

Troubleshooting

The base unit does not ring when there is an incoming call.

- Make sure there is a dial tone before dialing (page 4).
- Make sure the ringer volume of the base unit is not set to off (page 14).
- Make sure the DC power cable, telephone line cord, AC power cord, and the power adapter are plugged in properly (page 2).
- There may be too many extension phones on the telephone line to allow all of them to ring simultaneously. Unplug some of them.
- If other telephones in your office are having the same problem, the problem is in the wiring or telephone/PBX service. Contact your telephone service provider (charges may apply) or PBX system administrator.
- Disconnect the telephone line cord from the power adapter and plug it in a working telephone. If the other telephone also does not ring, the problem is probably in the telephone line cord. Try replacing the telephone line cord and retest.
- If the line cord has been replaced and both the ErisStation® Conference Phone with Wireless Mics and the other telephone do not ring, the problem is in the wall jack, wiring or telephone/PBX service. Contact your telephone service provider (charges may apply) or PBX system administrator.
- Other electronic products such as HAM radios and other DECT phones can cause interference with your conference phone. Try installing your conference phone as far away as possible from these types of electronic devices.
- Unplug the AC power cord from the wall outlet. Wait for approximately 15 seconds, and then plug it back in. If you still cannot see “**ErisStation**” on the LCD display, or cannot get a dial tone, please contact our customer service hotline designated above for assistance.

My wireless mic does not work at all.

The wireless mic works only when the base unit is properly powered and the wireless mic is lifted from the charging cradle.

If the wireless mic works, with the wireless mic lifted, the status indicator under the **MUTE** button turns green within 2 seconds when you press **TALK OFF** on the base unit.

If the status indicator remains off and inactive, please follow the steps below:

1. Remove the battery from battery compartment.
2. Insert the battery again and secure the battery door. Then, return the wireless mic to the charging cradle.
3. Make sure the wireless mic is placed in the charging cradle correctly (page 3). The status indicator under the **MUTE** button should turn orange.

If the status indicator remains off at the time the wireless mic returned to the charging cradle, the wireless mic or the charging cradle is probably defective. Please contact customer service for assistance.

If the status indicator does not turn orange, please follow the steps below:

1. Remove the wireless mic from the charging cradle and install the battery again (page 3).
2. Return the wireless mic to the charging cradle. The status indicator under the **MUTE** button should turn orange. The wireless mic is charging now.
3. Allow the wireless mic to be charged for at least 30 minutes.
4. Remove the wireless mic from the charging cradle again.
5. Press **TALK OFF**, the status indicator under **MUTE** button should turn green within 2 seconds.

Troubleshooting

If that still does not work, the wireless mic might have lost its connection to the base unit.

1. Re-register all the wireless mics with the base unit (page 27).
2. Remove the wireless mic from the charging cradle.
3. Press **TALK OFF** again. The status indicator under the **MUTE** button should turn green.

If that still does not work, you might have a defective battery or a defective wireless mic.

Please contact customer service for assistance.

note

- Every time the base unit is powered up, the wireless mics will need some time to connect to the base unit. Please allow at least one minute for the wireless mic and base unit to synchronize before use after the base unit has powered up.
- If you have more than one ErisStation® Conference Phone in the office, use the paging function (page 12) to identify the wireless mics that are connected to the corresponding base unit. Make sure that they are not mixed up between each of your ErisStation® Conference Phone.

The callers cannot hear me when I am using the wireless mic.

- Make sure the wireless mic is not muted during a call.
- Move the wireless mic closer to the base unit. It may be out of range.
- Speak to the wireless mic (page 4) at a distance of no more than 3 feet.
- Reset the base unit. Unplug the AC power cord from the wall outlet. Wait for approximately 15 seconds, and then plug it back in. Allow at least one minute for the wireless mic and base unit to synchronize.
- If you have more than one ErisStation® Conference Phone in the office, use the paging function (page 12) to identify the wireless mics that are connected to the corresponding base unit. Make sure that they are not mixed up between each of your ErisStation® Conference Phone.
- Other electronic products such as HAM radios and other DECT phones can cause interference with your ErisStation® Conference Phone. Try installing your ErisStation® Conference Phone as far away as possible from these types of electronic devices.

Status Indicator on the wireless mic flashes orange.

The wireless mic has low battery.

- Place the wireless mic onto the charging cradle for recharging.

For optimal battery life performances:

- Charge the wireless mics for up to 8 hours before the first time of use.
- Return the wireless mics to the charging cradle after use. Charge them for at least 30 minutes before subsequent uses.

Troubleshooting

Status Indicator on the wireless mic flashes orange even after a long period of charging.

The efficiency of the battery might have been reduced after being used for some time.

- Make sure the wireless mic is placed in the charging cradle correctly (page 3) when charging.
- Remove and install the battery again (page 3) and use it until the battery is fully depleted, and then charge the wireless mic in charging cradle for 8 hours.
- If the above measures do not solve the problem, replace the battery.

The status indicator on the wireless mic does not turn orange when in charging cradle.

- The wireless mic might be fully charged.
- Clean the charging contacts on the wireless mic and the charging cradles each month with a pencil eraser or a dry non-abrasive fabric.
- Make sure the DC power cable, telephone line cord, AC power cord, and the power adapter are plugged in properly (page 2).
- Make sure the wireless mic is placed in the charging cradle correctly (page 3).
- Unplug the power cable. Wait for 15 seconds before plugging it back in. Allow up to one minute for the wireless mic and base unit to reset.
- Lift the wireless mic and place it back into the charging cradle. If the wireless mic status indicator turns orange for 5 seconds, and then lights off, the battery is fully charged.

There is interference during a telephone conversation.

My calls fade out when I am using the wireless mic.

- Move the wireless mic closer to the base unit. It may be out of range.
- If you subscribe to high-speed Internet service (DSL - digital subscriber line) through your telephone line, you must install a DSL filter between the telephone line cord and the telephone wall jack. The filter prevents noise and caller ID problems caused by DSL interference. Contact your DSL service provider for more information about DSL filters.
- Appliances plugged into the same circuit as the base unit can cause interference. Try moving the appliance or base unit to another outlet.
- Other electronic products such as HAM radios and other DECT phones can cause interference with your conference phone. Try installing your conference phone as far away as possible from these types of electronic devices.
- If your telephone is plugged into a modem or a surge protector, plug the telephone (or modem/surge protector) into a different location. If this doesn't solve the problem, relocate your telephone or modem farther apart from each other, or use a different surge protector.
- If other telephones in your office are having the same problem, the problem is in the wiring or telephone/PBX service. Contact your telephone service provider (charges may apply) or PBX system administrator.

Troubleshooting

I hear other calls when using the telephone.

- Disconnect the base unit from the telephone wall jack. Plug in a different telephone. If you still hear other calls, the problem is probably in the wiring or telephone/PBX service. Contact your telephone service provider (charges may apply) or PBX system administrator.

My caller ID features are not working properly.

If you are using a PSTN line, please refer to the details below:

- Caller ID is a subscription service. You must subscribe to this service from your telephone service provider for this feature to work on your telephone.
- The caller may not be calling from an area which supports caller ID.
- Both your and the caller's telephone service providers must use equipment compatible with the caller ID service.
- The caller ID information shows after the first or second ring.
- If you subscribe to high-speed Internet service (DSL - digital subscriber line) through your telephone line, you must install a DSL filter between the telephone line cord and the telephone wall jack. The filter prevents noise and caller ID problems caused by DSL interference. Contact your DSL service provider for more information about DSL filters.

If you are using a PBX extension line, please note:

- PBX switches do not transfer caller ID to extension lines. Please contact your PBX system administrator for more information.

The ErisStation® Conference Phone does not receive caller ID while on a call.

- The ErisStation® Conference Phone does not support type II caller ID. No caller ID is shown when the line is already in use during a call.

I have accidentally set my LCD language to Spanish or French, and I don't know how to change it back to English.

- When the base unit is not in use or on a call, press $\frac{\text{MENU}}{\text{SELECT}}$ once, and then enter $\text{^{tone}X364\#}$.

Common cure for electronic equipment.

- If the telephone is not responding normally, put the wireless mics onto the charging cradles. If it does not respond, try the following (in the order listed):
 1. Disconnect the power to the base unit.
 2. Remove the battery from the wireless mics.
 3. Wait a few minutes before connecting power to the base unit.
 4. Install the battery again and place the wireless mics onto the charging cradles.
 5. Wait for the wireless mic to synchronize with the base unit. Allow up to one minute for this to take place.

Maintenance

Taking care of your ErisStation® Conference Phone

Your conference phone contains sophisticated electronic parts, so it must be treated with care.

Avoid rough treatment

Place the wireless mic down gently. Save the original packing materials to protect your ErisStation® Conference Phone if you ever need to ship it.

Avoid water

Your ErisStation® Conference Phone can be damaged if it gets wet. Do not use the wireless mic outdoors in the rain, or handle it with wet hands. Do not install the base unit near a sink, bathtub or shower.

Electrical storms

Electrical storms can sometimes cause power surges harmful to electronic equipment. For your own safety, take caution when using electrical appliances during storms.

Cleaning your ErisStation® Conference Phone

Your ErisStation® Conference Phone has a durable plastic casing that should retain its luster for many years. Clean it only with a soft cloth slightly dampened with water or mild soap. Do not use excess water or cleaning solvents of any kind.

Remember that electrical appliances can cause serious injury if used when you are wet or standing in water. If the base unit should fall into water, DO NOT RETRIEVE IT UNTIL YOU UNPLUG THE AC POWER CORD AND TELEPHONE LINE CORD FROM THE WALL. Then, remove the telephone by the unplugged cords.

FCC, ACTA and IC regulations

FCC Part 15

This equipment has been tested and found to comply with the requirements for a Class B digital device under Part 15 of the Federal Communications Commission (FCC) rules. These requirements are intended to provide reasonable protection against harmful interference in a residential installation. This equipment generates, uses and can radiate radio frequency energy and, if not installed and used in accordance with the instructions, may cause harmful interference to radio communications. However, there is no guarantee that interference will not occur in a particular installation. If this equipment does cause harmful interference to radio or television reception, which can be determined by turning the equipment off and on, the user is encouraged to try to correct the interference by one or more of the following measures:

- Reorient or relocate the receiving antenna.
- Increase the separation between the equipment and receiver.
- Connect the equipment into an outlet on a circuit different from that to which the receiver is connected.
- Consult the dealer or an experienced radio/TV technician for help.

Changes or modifications to this equipment not expressly approved by the party responsible for compliance could void the user's authority to operate the equipment.

This device complies with Part 15 of the FCC rules and the Industry Canada Licence-exempt RSS standard. Operation is subject to the following two conditions: (1) this device may not cause harmful interference, and (2) this device must accept any interference received, including interference that may cause undesired operation. Privacy of communications may not be ensured when using this telephone.

To ensure safety of users, the FCC has established criteria for the amount of radio frequency energy that can be safely absorbed by a user or bystander according to the intended usage of the product. This product has been tested and found to comply with the FCC criteria. The wireless mic may be safely held against the face of the user. The base unit shall be installed and used such that parts of the user's body other than the hands are maintained at a distance of approximately 20 cm (8 inches) or more.

This Class B digital apparatus complies with Canadian requirement:
CAN ICES-3 (B)/NMB-3(B)

FCC Part 68 and ACTA

This equipment complies with Part 68 of the FCC rules and with technical requirements adopted by the Administrative Council for Terminal Attachments (ACTA). The label on the back or bottom of this equipment contains, among other things, a product identifier in the format US:AAAEQ##TXXXX. This identifier must be provided to your telephone service provider upon request.

The plug and jack used to connect this equipment to premises wiring and the telephone network must comply with applicable Part 68 rules and technical requirements adopted by ACTA. A compliant telephone cord and modular plug is provided with this product. It is designed to be connected to a compatible modular jack that is also compliant. An RJ11 jack should normally be used for connecting to a single line and an RJ14 jack for two lines. See the installation instructions in the user's manual.

The Ringer Equivalence Number (REN) is used to determine how many devices you may connect to your telephone line and still have them ring when you are called. The REN for this product is encoded as the 6th and 7th characters following the US: in the product identifier (e.g., if ## is 03, the REN is 0.3). In most, but not all areas, the sum of all RENs should be five (5.0) or less. For more information, please contact your telephone service provider.

This equipment may not be used with Party Lines. If you have specially wired alarm dialing equipment connected to your telephone line, ensure the connection of this equipment does not disable your alarm equipment. If you have questions about what will disable alarm equipment, consult your telephone service provider or a qualified installer.

FCC, ACTA and IC regulations

If this equipment is malfunctioning, it must be unplugged from the modular jack until the problem has been corrected. Repairs to this telephone equipment can only be made by the manufacturer or its authorized agents. For repair procedures, follow the instructions outlined under the Limited warranty. If this equipment is causing harm to the telephone network, the telephone service provider may temporarily discontinue your telephone service. The telephone service provider is required to notify you before interrupting service. If advance notice is not practical, you will be notified as soon as possible. You will be given the opportunity to correct the problem and the telephone service provider is required to inform you of your right to file a complaint with the FCC. Your telephone service provider may make changes in its facilities, equipment, operation, or procedures that could affect the proper functioning of this product. The telephone service provider is required to notify you if such changes are planned.

If this product is equipped with a corded or cordless handset, it is hearing aid compatible.

If this product has memory dialing locations, you may choose to store emergency telephone numbers (e.g., police, fire, medical) in these locations. If you do store or test emergency numbers, please:

Remain on the line and briefly explain the reason for the call before hanging up.

Perform such activities in off-peak hours, such as early morning or late evening.

Industry Canada

Operation is subject to the following two conditions: (1) this device may not cause harmful interference, and (2) this device must accept any interference received, including interference that may cause undesired operation.

Privacy of communications may not be ensured when using this telephone.

The term "IC:" before the certification/registration number only signifies that the Industry Canada technical specifications were met.

The Ringer Equivalence Number (REN) for this terminal equipment is 0.1. The REN indicates the maximum number of devices allowed to be connected to a telephone interface. The termination of an interface may consist of any combination of devices subject only to the requirement that the sum of the RENs of all the devices not exceed five.

This product meets the applicable Innovation, Science and Economic Development Canada technical specifications.

The RBRC[®] seal



The RBRC[®] Seal means that the manufacturer is voluntarily participating in an industry program to collect and recycle nickel-metal hydride rechargeable batteries when taken out of service within the United States. These batteries may be taken to a participating local retailer of replacement batteries or recycling center. Or you may call **1 (800) 8 BATTERY[®]** for locations accepting spent Ni-MH batteries.

RBRC[®] and 1 (800) 8 BATTERY[®] are registered trademarks of the Rechargeable Battery Recycling Corporation.

California Energy Commission battery charging testing instructions

This telephone is set up to comply with the energy-conserving standards right out of the box. These instructions are intended for California Energy Commission (CEC) compliance testing only. When the CEC battery charging testing mode is activated, all telephone functions, except battery charging, will be disabled.

To activate the CEC battery charging testing mode:

1. Place all wireless mics (with batteries inserted) into the base unit to make sure they can work normally with the base unit.
2. Unplug the power cable from the power outlet.
3. While you press and hold **MUTE** on the base unit, plug the power cable back to the power outlet.
4. After about 20 seconds, when the base unit status indicators start flashing, release **MUTE** and then press it again within 1 second. After one minute, the base unit will enter the CEC battery charging testing mode.

After about one minute, the base unit will enter the CEC battery charging testing mode. The base indicators turn off and all wireless mics are will be deregistered. All telephone functions, except battery charging will be disabled.

If the base unit has failed to enter this mode, repeat Step 1 through Step 4 above.

note The base unit will be powered up as normal if you fail to press **MUTE** within 1 second in Step 4.

To deactivate the CEC battery charging testing mode:

- Unplug the power cable from the power outlet, and then plug it back in. The base unit is powered up as normal. See page 27 for wireless mic registration instructions.

For C-UL compliance only

Mesures de sécurité importantes

Vous devez toujours observer des mesures de précaution lorsque vous utilisez le Téléphone de conférence ErisStation®, afin d'éviter les risques d'incendie, d'électrocution et de blessures, incluant ce qui suit :

1. Lisez et comprenez bien toutes les instructions.
2. Observez toutes les instructions et mises en garde inscrites sur l'appareil.
3. Débranchez ce téléphone de la prise murale avant de le nettoyer. N'utilisez pas de nettoyeurs liquides ni en aérosol. N'utilisez qu'un chiffon doux et légèrement humecté.
4. N'utilisez pas ce produit près de l'eau, tel que près d'un bain, d'un lavabo, d'un évier de cuisine, d'un bac de lavage ou d'une piscine, ou dans un sous-sol humide ou sous la douche.
5. Pour les PRODUITS À BRANCHER À UNE PRISE DE COURANT, la prise de courant doit être installée près du produit, afin d'assurer une accessibilité sécuritaire à la prise de courant.
6. **MISE EN GARDE** : Il peut y avoir un risque d'explosion si vous utilisez le mauvais type de piles. N'utilisez que le bloc-piles rechargeable inclus ou le bloc-piles de recharge (BT183642/BT283642). N'incinerez pas les piles. Celles-ci risqueraient d'exploser. Jetez les piles usées selon les renseignements suivant **le sceau du RBRC^{MD}**.
7. Ne déposez pas ce téléphone sur un chariot, support ou table chancelants. L'appareil pourrait tomber et être sérieusement endommagé.
8. Les ouvertures situées à l'arrière ou sous le socle et le microphone sans fil servent à la ventilation. Afin d'empêcher la surchauffe, ces ouvertures ne doivent pas être obstruées en plaçant l'appareil sur un lit, divan, tapis ou autre surface similaires. Ne placez pas cet appareil à proximité d'un élément de chauffage ni d'une plinthe électrique. De plus, ne l'installez pas dans une unité murale ou un cabinet fermé qui ne possède pas d'aération adéquate.
9. N'utilisez que les adaptateurs inclus avec ce produit. L'utilisation d'un adaptateur dont la polarité ou la tension serait inadéquate risque d'endommager sérieusement le produit et mettre votre sécurité en péril. Adaptateur : Entrée 100-240V CA 50/60 Hz; Sortie : 9 V CC 1500 mA.
10. Ne faites fonctionner cet appareil qu'avec le type d'alimentation indiqué sur les étiquettes de l'appareil. Si vous ne connaissez pas le voltage de votre maison, consultez votre marchand ou votre fournisseur d'électricité.
11. Ne déposez rien sur le cordon d'alimentation. Installez cet appareil dans un endroit sécuritaire, là où personne ne pourra trébucher sur la ligne d'alimentation ni le cordon téléphonique modulaire.
12. N'enfoncez jamais d'objets dans les fentes du socle ou du microphone sans fil, car ceci risquerait d'entrer en contact avec des points de tension dangereux ou provoquer un court-circuit. N'échappez pas de liquides dans l'appareil.
13. Afin de réduire les risques d'électrocution, ne démontez pas l'appareil, mais apportez-le plutôt à un centre de service qualifié s'il doit être réparé. L'ouverture ou le retrait de pièces du socle ou du microphone sans fil autre que les portes d'accès peuvent vous exposer à des tensions dangereuses et à d'autres risques. Débranchez l'appareil avant de procéder au nettoyage. Utilisez un chiffon humide et doux.
14. Ne surchargez pas les prises de courant et les rallonges.
15. Débranchez cet appareil de la prise de courant et communiquez avec le département de service à la clientèle de VTech dans les cas suivants :
 - Lorsque le cordon d'alimentation est endommagé ou écorché.
 - Si du liquide a été échappé dans l'appareil.
 - Si l'appareil a été exposé à une source d'humidité telle que la pluie ou l'eau.
 - Si le produit ne fonctionne pas normalement en respectant les instructions de fonctionnement. Réglez uniquement les commandes indiquées dans les instructions de fonctionnement. Les réglages incorrects des autres commandes pourraient provoquer un dommage qui pourrait exiger un travail exhaustif de la part d'un technicien autorisé afin de rétablir le fonctionnement normal de l'appareil.
 - Si le produit a été échappé et que le socle et/ou le microphone sans fil a été endommagé.
 - Si le produit affiche une nette diminution de sa performance.
16. Évitez d'utiliser le Téléphone de conférence ErisStation® pendant un orage.
17. N'utilisez pas le Téléphone de conférence ErisStation® pour rapporter une fuite de gaz à proximité de la fuite. En certaines circonstances, une flammèche pourrait être provoquée lorsque l'adaptateur est branché dans une prise de courant ou lorsque le microphone auxiliaire est déposé sur son socle. Ceci est un événement commun associé à la fermeture d'un circuit électrique. L'utilisateur ne doit pas brancher le téléphone dans une prise de courant ni insérer un microphone sans fil rechargé dans le socle, si le téléphone se trouve dans un environnement contenant des concentrations de matières inflammables ou autres gaz susceptibles de produire des flammes, sauf en présence d'une aération adéquate. Une flammèche dans un tel endroit pourrait provoquer un incendie ou une explosion. De tels environnements peuvent comprendre: des endroits où l'on utilise de l'oxygène médical sans ventilation adéquate; des gaz industriels (dissolvants de nettoyage, des vapeurs d'essence, etc.); une fuite de gaz naturel, etc.

For C-UL compliance only

18. Ne déposez que le microphone sans fil près de votre oreille que lorsqu'il est en mode de conversation normale.
19. Ces adaptateurs ont été conçus pour être orientés en position verticale ou montés au sol. Les broches ne sont pas conçues pour maintenir l'adaptateur en place si celui-ci est branché dans une prise au plafond ou sous une table/ armoire.

CONSERVEZ CES INSTRUCTIONS

Pile

- **MISE EN GARDE** : N'utilisez que la pile incluse.
- Ne jetez pas la pile au feu. Vérifiez les instructions spécifiques de mise aux rebus auprès des autorités locales.
- N'ouvrez pas et ne mutilez pas la pile. L'électrolyte qui s'en échapperait est corrosif et pourrait causer des brûlures ou des blessures aux yeux ou à la peau. L'électrolyte est toxique si avalé.
- Soyez prudents lorsque vous manipulez les piles afin d'éviter les courts-circuits provoqués par des matériaux conducteurs.
- Rechargez la pile incluse avec cet appareil, selon les instructions et limites spécifiées dans ce guide d'utilisation.

Stimulateurs cardiaques implantés dans l'organisme

Les simulateurs cardiaques (s'applique uniquement aux téléphones numériques sans fil):

L'organisme 'Wireless Technology Research, LLC (WTR)', une firme de recherche indépendante, a mené une évaluation pluridisciplinaire des interférences entre les téléphones sans fil portatifs et les stimulateurs cardiaques implantés dans l'organisme. Appuyée par l'Administration des aliments et drogues (FDA) des États-Unis, la firme WTR recommande aux médecins:

Avis aux détenteurs de stimulateurs cardiaques

- Ils doivent tenir le téléphone sans fil à une distance d'au moins six pouces du stimulateur cardiaque.
- Ils ne doivent PAS placer le téléphone sans fil directement sur le stimulateur cardiaque, tel que dans une poche de chemise, lorsque celui-ci est en marche.
- Ils doivent utiliser le téléphone sans fil en l'appuyant sur l'oreille qui se trouve dans la direction opposée au stimulateur cardiaque.

L'étude effectuée par l'organisme WRS n'a pas identifié de risque pour les détenteurs de simulateurs cardiaques causés par les gens qui utilisent un téléphone sans fil à proximité de ceux-ci.

propos des microphones sans fil

- **Confidentialité:** Les mêmes caractéristiques qui constituent des avantages pour les téléphones sans fil affichent également des restrictions. Les appels téléphoniques sur les téléphones conférence sans fil sont transmis entre le combiné sans fil et le socle par le biais d'ondes radio ; il y a donc la possibilité que vos conversations téléphoniques sans fil soient interceptées par des équipements de réception radio se trouvant dans la portée du combiné sans fil. Pour cette raison, vous ne devez pas percevoir les communications sur les téléphones conférence sans fil comme étant aussi confidentielles que celles des téléphones à cordons.
- **Alimentation électrique:** Le socle de ce téléphone conférence sans fil doit être branché à une prise électrique fonctionnelle. La prise électrique ne doit pas être contrôlée par un interrupteur mural. Les appels ne pourront pas être effectués du téléphone conférence sans fil si le socle est débranché ou mis hors tension ou si le courant est interrompu.
- **Possibilité d'interférences aux téléviseurs:** Certains microphones sans fil fonctionnent sur des fréquences pouvant causer des interférences aux téléviseurs et aux magnétoscopes. Pour réduire ou prévenir de telles interférences, ne placez pas le socle du téléphone sans fil à proximité ou sur un téléviseur ou magnétoscope. S'il y a présence de parasites, il est conseillé d'éloigner le téléphone sans fil du téléviseur ou du magnétoscope afin de réduire possiblement les interférences.
- **Piles rechargeables:** Manipulez les piles avec soin afin de ne pas les court-circuiter avec des bagues, bracelets ou clés. Les piles ou le conducteur peut surchauffer et causer des blessures.
- **Piles rechargeables l'hydrure métallique de nickel:** Jetez ces blocs-piles de manière écologique et sécuritaire. Ne les incinerez pas et ne les percez pas. Tel que les autres piles de ce type, elles pourraient dégager une matière toxique qui peut causer des blessures corporelles si elles sont brûlées ou percées.

Limited warranty

What does this limited warranty cover?

The manufacturer of this VTech Product warrants to the holder of a valid proof of purchase (“Consumer” or “you”) that the Product and all accessories provided in the sales package (“Product”) are free from defects in material and workmanship, pursuant to the following terms and conditions, when installed and used normally and in accordance with the Product operating instructions. This limited warranty extends only to the Consumer for Products purchased and used in the United States of America and Canada.

What will VTech do if the Product is not free from defects in materials and workmanship during the limited warranty period (“Materially Defective Product”)?

During the limited warranty period, VTech’s authorized service representative will repair or replace at VTech’s option, without charge, a Materially Defective Product. If we repair the Product, we may use new or refurbished replacement parts. If we choose to replace the Product, we may replace it with a new or refurbished Product of the same or similar design. We will retain defective parts, modules, or equipment. Repair or replacement of the Product, at VTech’s option, is your exclusive remedy. VTech will return the repaired or replacement Products to you in working condition. You should expect the repair or replacement to take approximately 30 days.

How long is the limited warranty period?

The limited warranty period for the Product extends for TWO (2) YEARS from the date of purchase. If VTech repairs or replaces a Materially Defective Product under the terms of this limited warranty, this limited warranty also applies to the repaired or replacement Product for a period of either (a) 90 days from the date the repaired or replacement Product is shipped to you or (b) the time remaining on the original two-year warranty; whichever is longer.

What is not covered by this limited warranty?

This limited warranty does not cover:

1. Product that has been subjected to misuse, accident, shipping or other physical damage, improper installation, abnormal operation or handling, neglect, inundation, fire, water or other liquid intrusion; or
2. Product that has been damaged due to repair, alteration or modification by anyone other than an authorized service representative of VTech; or
3. Product to the extent that the problem experienced is caused by signal conditions, network reliability, or cable or antenna systems; or
4. Product to the extent that the problem is caused by use with non-VTech accessories; or
5. Product whose warranty/quality stickers, product serial number plates or electronic serial numbers have been removed, altered or rendered illegible; or
6. Product purchased, used, serviced, or shipped for repair from outside the United States of America or Canada, or used for commercial or institutional purposes (including but not limited to Products used for rental purposes); or
7. Product returned without a valid proof of purchase (see item 2 on the next page); or
8. Charges for installation or set up, adjustment of customer controls, and installation or repair of systems outside the unit.

Limited warranty

How do you get warranty service?

To obtain warranty service in the USA, please visit our website at <http://businessphones.vtech.com> or call **1-800-595-9511**. In Canada, call **1-800-267-7377**.

NOTE: Before calling for service, please review the user's manual - a check of the Product's controls and features may save you a service call.

Except as provided by applicable law, you assume the risk of loss or damage during transit and transportation and are responsible for delivery or handling charges incurred in the transport of the Product(s) to the service location. VTech will return repaired or replaced Product under this limited warranty. Transportation, delivery or handling charges are prepaid. VTech assumes no risk for damage or loss of the Product in transit. If the Product failure is not covered by this limited warranty, or proof of purchase does not meet the terms of this limited warranty, VTech will notify you and will request that you authorize the cost of repair prior to any further repair activity. You must pay for the cost of repair and return shipping costs for the repair of Products that are not covered by this limited warranty.

What must you return with the Product to get warranty service?

1. Return the entire original package and contents including the Product to the VTech service location along with a description of the malfunction or difficulty; and
2. Include a "valid proof of purchase" (sales receipt) identifying the Product purchased (Product model) and the date of purchase or receipt; and
3. Provide your name, complete and correct mailing address, and telephone number.

Other limitations

This warranty is the complete and exclusive agreement between you and VTech. It supersedes all other written or oral communications related to this Product. VTech provides no other warranties for this Product. The warranty exclusively describes all of VTech's responsibilities regarding the Product. There are no other express warranties. No one is authorized to make modifications to this limited warranty and you should not rely on any such modification.

State/Provincial Law Rights: This warranty gives you specific legal rights, and you may also have other rights, which vary from state to state or province to province.

Limitations: Implied warranties, including those of fitness for a particular purpose and merchantability (an unwritten warranty that the Product is fit for ordinary use) are limited to two years from the date of purchase. Some states/provinces do not allow limitations on how long an implied warranty lasts, so the above limitation may not apply to you. In no event shall VTech be liable for any indirect, special, incidental, consequential, or similar damages (including, but not limited to lost profits or revenue, inability to use the Product or other associated equipment, the cost of substitute equipment, and claims by third parties) resulting from the use of this Product. Some states/provinces do not allow the exclusion or limitation of incidental or consequential damages, so the above limitation or exclusion may not apply to you.

Please retain your original sales receipt as proof of purchase.

Technical specifications

Frequency control	Crystal controlled PLL synthesizer
Transmit frequency	Wireless mic: 1921.536-1928.448 MHz Base unit: 1921.536-1928.448 MHz
Channels	5
Nominal effective range	Maximum power allowed by FCC and IC. Actual operating range may vary according to environmental conditions at the time of use.
Optimal and minimum distances	Optimal distance between the base unit/wireless mic and the participant: 2 feet Minimum distance between each wireless mic: 1 foot
Power requirements	Wireless mic: Ni-MH Battery Pack; 2.4V; 400mAH rechargeable battery Base unit adapter: Input: 100-240V AC 50/60Hz Output: 9V DC @ 1500mA
Memory	Phonebook: 50 memory locations; up to 30 digits and 15 characters Call log: 50 memory locations; up to 16 digits and 15 characters



Designed to fit your home.
And your life.

VTech Communications, Inc.

A member of THE VTECH GROUP OF COMPANIES.

VTech is a registered trademark of VTech Holdings Limited.

ErisStation® and Orbitlink Wireless Technology™ are trademarks of
VTech Communications, Inc.

Specifications are subject to change without notice.

© 2016 for VTech Communications, Inc.

All rights reserved. Version 11. 10/16.

