

Go to www.vtechphones.com to register your product for enhanced warranty support and latest VTech product news.

VC931

2.4GHz Pan and Tilt
IP Wi-Fi Camera

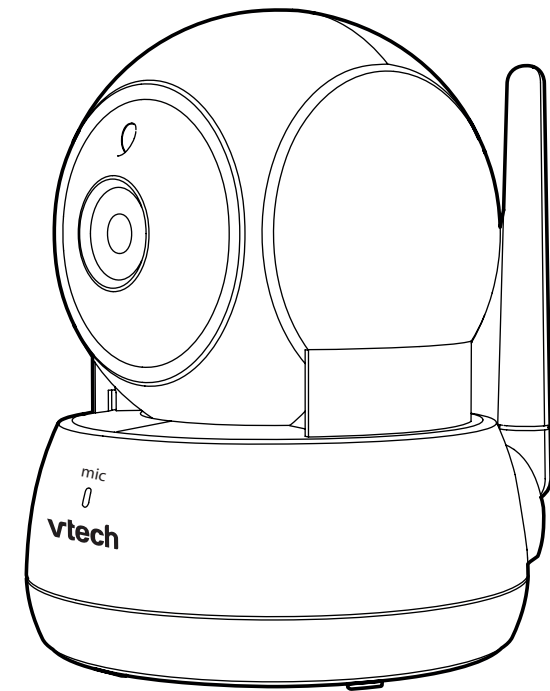

vtech®

User's manual

Congratulations

on purchasing your new VTech product. Before using this telephone, please read **Important safety instructions**.

For support, shopping, and everything new at VTech, visit our website at www.vtechphones.com.

What's in the box

Your camera package contains the following items. Save your sales receipt and original packaging in the event warranty service is necessary.

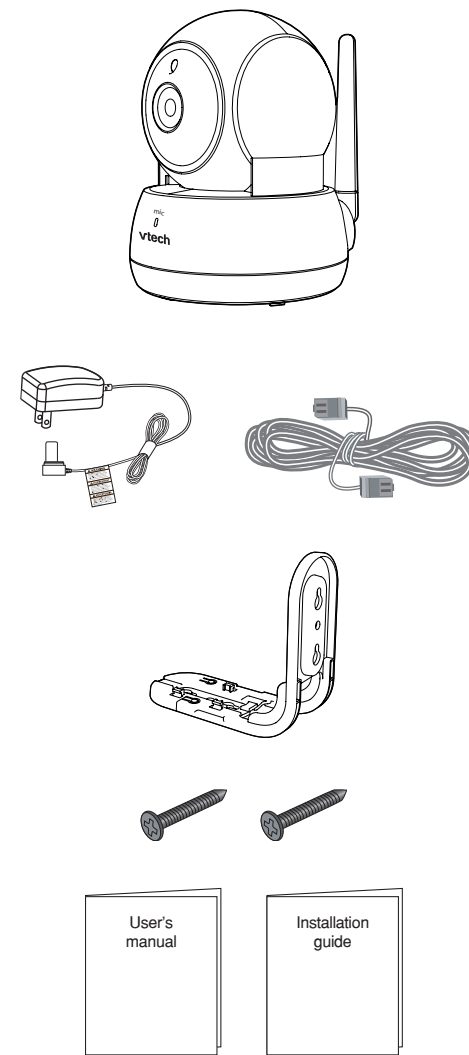

Overview

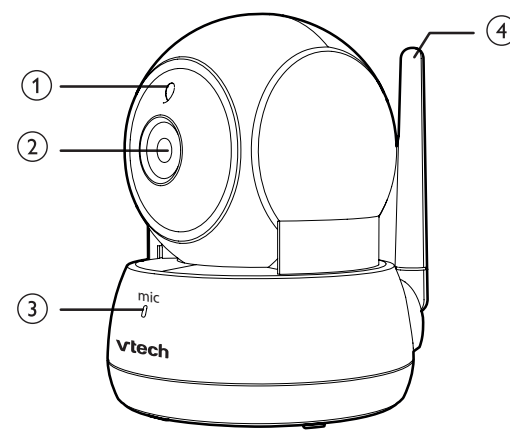

- 1 – Infrared LED
 - Backup light for night vision.
- 2 – Camera lens
- 3 – Microphone
- 4 – Antenna
 - Connect to router with Wi-Fi.

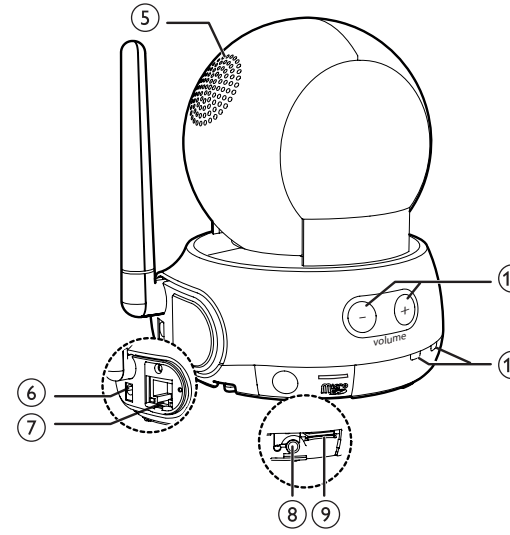

- 5 – Speaker
- 6 – Power jack
- 7 – RJ45 jack
 - Connection to router with a network cable.
- 8 – 3.5mm line jack
 - Connect to audio output device.

9 – MicroSD card slot

- 10 – Volume –
 - Press to decrease the listening volume.
- Volume +
 - Press to increase the listening volume.

11 – LED indicators

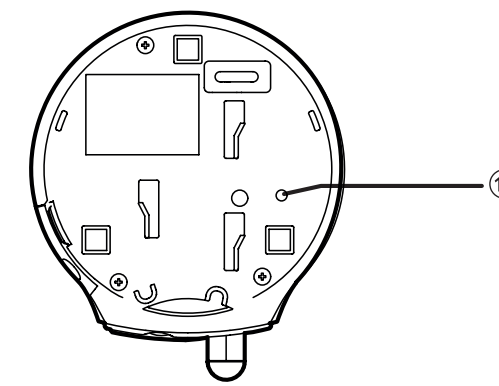

12 – Reset button

Connect

You can choose to connect the camera unit for desktop usage, wall mounting or ceiling mounting.

TIP

For desktop usage, wall mounting and/or ceiling mounting the camera unit, you can refer to the Installation guide.

NOTES

- Use only the camera power adapter supplied with this product.
- Make sure the electrical outlets are not controlled by wall switches.
- The power adapter is intended to be correctly oriented in a vertical or floor mount position. The prongs are not designed to hold the plug in place if it is plugged into a ceiling, under-the-table or cabinet outlet.
- Make sure the camera unit and the power adapter cord are out of reach of children.

Connect the IP Camera

Make sure you have setup an IEEE 802.11n router (not included).

You can then choose to connect the camera unit with cable connection or Wi-Fi connection.

1. For cable connection, connect the camera unit and the router with a network cable.
- For Wi-Fi connection, skip to step 2. Do not plug in the network cable.

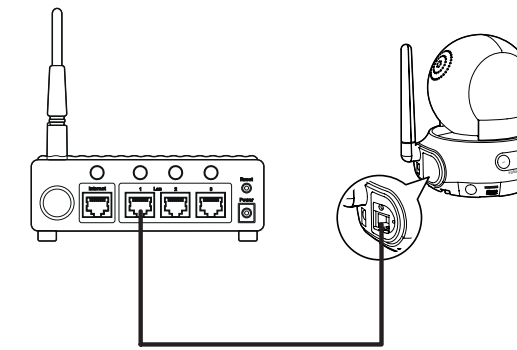

2. Connect the power adapter to the camera unit and a power supply not controlled by a wall switch.

NOTES

- If you use Wi-Fi connection, check the Wi-Fi coverage of your router. Place the camera unit at a desired place.
- To maintain compliance with the FCC's RF exposure guidelines, place the IP camera at least 20cm from nearby persons.

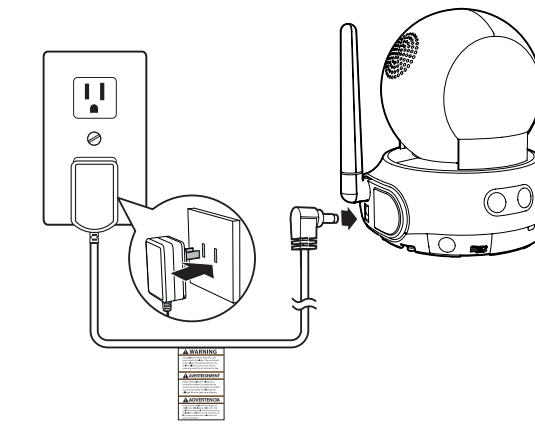

When the camera announces "Ready to monitor", you can add the camera to your mobile app.

Add camera

Add IP Camera to your mobile app

Login

1. After you have downloaded "vtech connect", create an account and then login.

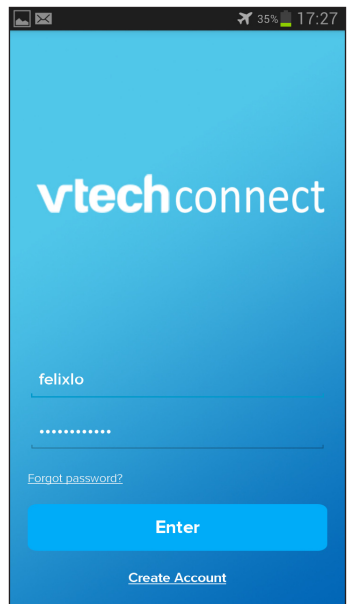

2. Tab **Continue**.

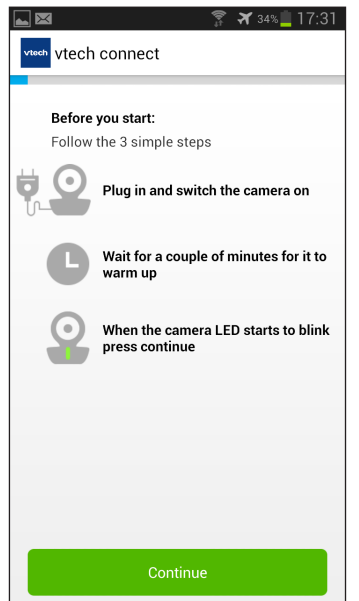

3. Tab **Search for camera** to add the camera unit.

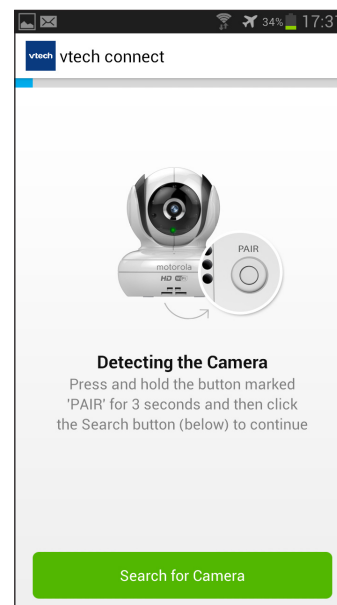

4. If you are using Wi-Fi for connection, select the Wi-Fi network and tab **Continue**.

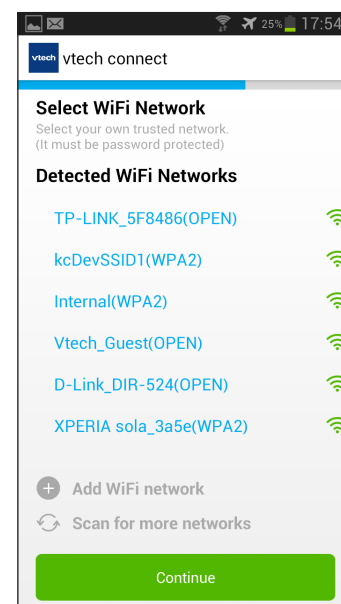

5. When you have successfully added the camera unit, tab **View Live Camera** to start viewing.

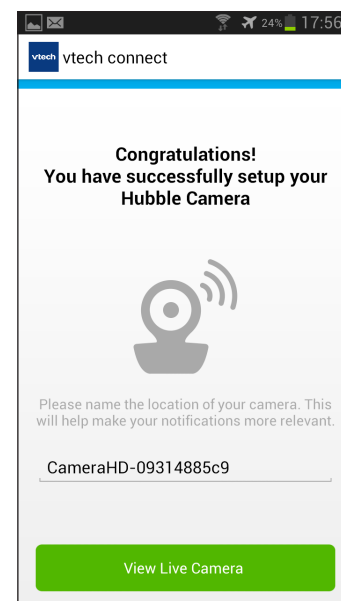
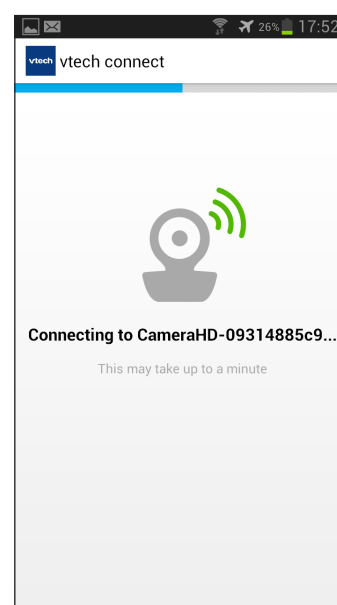

Using the IP camera

Camera operations

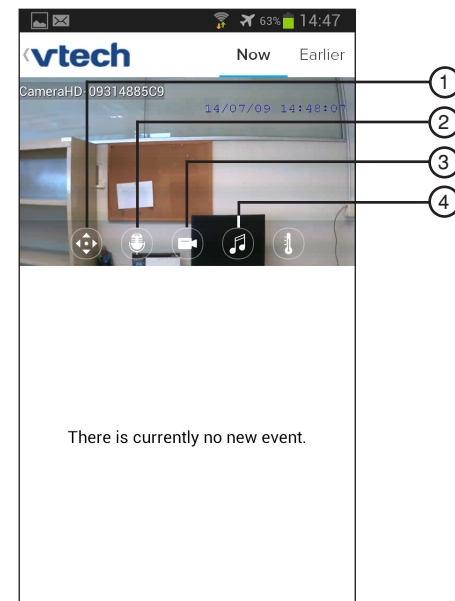

- 1 – Camera live view
 - Touch to switch to camera live view mode.
- 2 – Touch to talk
 - Touch to switch to talk mode.
- 3 – Take photo or record video
 - Touch to switch to snapshot/video mode.
- 4 – Play melody
 - Touch to select a melody.

Camera live view

Touch ▲, ▼, ◀ or ▶ to move the camera upward, downward, leftward or rightward; or touch and hold to pan or tilt the camera.

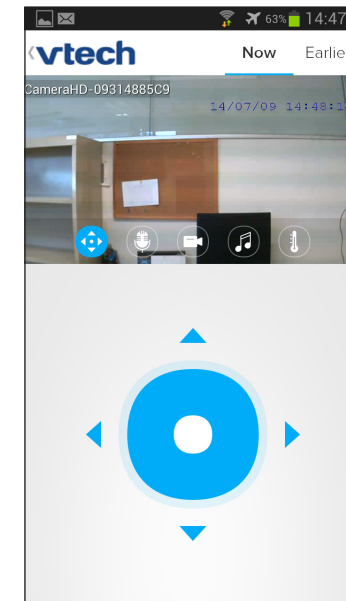

Touch to talk

Touch to talk through the camera speaker.

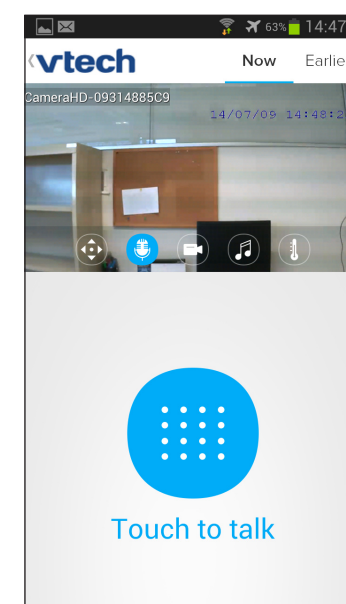

Take photo or record video

1. Touch to take a snapshot of the current view.

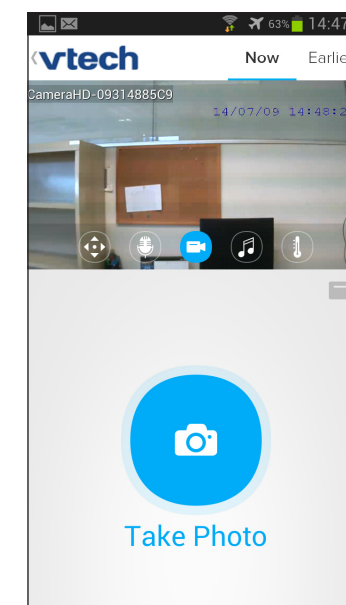

2. Touch the video icon on the right below the live view to switch to record video mode.
3. Touch to record a video of the current view.
4. Touch the camera icon will switch back to take photo mode.

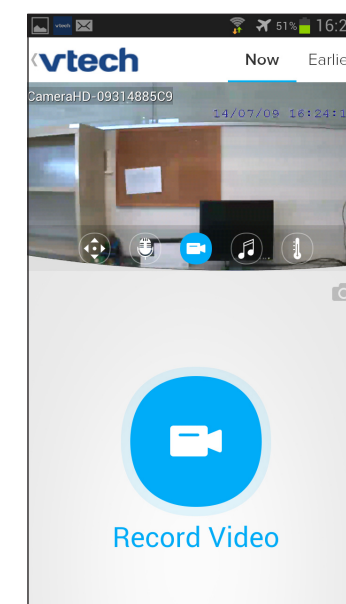

Play melody

Touch ▶ to play a melody from the camera speaker. There are five melodies available.

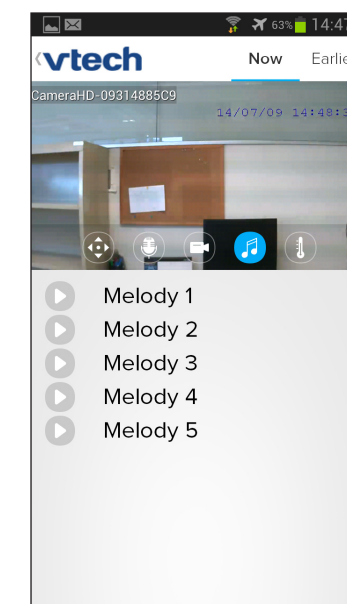

TIP

If connection fails, press the **Reset** button on the bottom of the camera unit for five seconds to reboot the camera, and then add the camera again.

General product care

To keep this product working well and looking good, follow these guidelines:

- Avoid putting it near heating appliances and devices that generate electrical noise (for example, motors or fluorescent lamps).
- DO NOT expose it to direct sunlight or moisture.
- Avoid dropping the product or treating it roughly.
- Clean with a soft cloth.
- DO NOT immerse the camera unit in water and do not clean it under the tap.
- DO NOT use cleaning spray or liquid cleaners.
- Make sure the camera unit is dry before you connect it to the mains again.

Storage

When you are not going to use the IP camera for some time, store the camera unit and the adapter in a cool and dry place.

Important safety instructions

When using your equipment, basic safety precautions should always be followed to reduce the risk of fire, electric shock and injury, including the following:

- Follow all warnings and instructions marked on the product.
- Adult setup is required.
- This home monitor is intended as an aid. It is not a substitute for home security supervision and should not be used as such.
- This product is not intended for use as a medical monitor.
- Do not use this product near water. For example, do not use it next to a bath tub, wash bowl, kitchen sink, laundry tub or swimming pool, or in a wet basement or shower.
- Use only the adapters included with this product. Incorrect adapter polarity or voltage can seriously damage the product. Power adapter: Input 100-240V AC 400mA 50/60Hz; Output: 5V DC 2000mA
- The power adapter is intended to be correctly oriented in a vertical or floor mount position. The prongs are not designed to hold the plug in place if it is plugged into a ceiling, under-the-table or cabinet outlet.
- Unplug this product from the wall outlet before cleaning. Do not use liquid or aerosol cleaners. Use a damp cloth for cleaning.
- Unplug the power cords before replacing batteries.
- Do not cut off the power adapters to replace them with other plugs, as this causes a hazardous situation.
- Do not allow anything to rest on the power cords. Do not install this product where the cords may be walked on or crimped.
- This product should be operated only from the type of power source indicated on the marking label. If you are not sure of the type of power supply in your home, consult your dealer or local power company.
- Do not overload wall outlets or use an extension cord.
- Do not place this product on an unstable table, shelf, stand or other unstable surfaces.
- This product should not be placed in any area where proper ventilation is not provided. Slots and openings in the back or bottom of this product are provided for ventilation. To protect them from overheating, these openings must not be blocked by placing the product on a soft surface such as a bed, sofa or rug. This product should never be placed near or over a radiator or heat register.
- Never push objects of any kind into this product through the slots because they may touch dangerous voltage points or create a

short circuit. Never spill liquid of any kind on the product.

- To reduce the risk of electric shock, do not disassemble this product, but take it to an authorized service facility. Opening or removing parts of the product other than specified access doors may expose you to dangerous voltages or other risks. Incorrect reassembling can cause electric shock when the product is subsequently used.
- You should test the sound reception every time you turn on the units or move one of the components.
- Periodically examine all components for damage.
- Be aware of possible loss of privacy while using public airwaves. Conversations may be picked up by other nursery monitors, cordless phones, scanners, etc.
- Children should be supervised to ensure that they do not play with the product.
- The small parts of this monitor can be swallowed by babies or small children. Keep these parts out of reach of children.
- The product is not intended for use by persons (including children) with reduced physical, sensory or mental capabilities, or lack of experience and knowledge, unless they have been given supervision or instruction concerning use of the appliance by a person responsible for their safety.

SAVE THESE INSTRUCTIONS

Cautions

- Use and store the product at a temperature between 32°F and 104°F.
- Do not expose the product to extreme cold, heat or direct sunlight. Do not put the product close to a heating source.
- Other electronic products may cause interference with your IP camera. Try installing your IP camera as far away from these electronic devices as possible: wireless routers, radios, cellular telephones, intercoms, room monitors, televisions, personal computers, kitchen appliances and cordless telephones.

Precautions for users of implanted cardiac pacemakers

Cardiac pacemakers (applies only to digital cordless devices): Wireless Technology Research, LLC (WTR), an independent research entity, led a multidisciplinary evaluation of the interference between portable wireless devices and implanted cardiac pacemakers. Supported by the U.S. Food and Drug Administration, WTR recommends to physicians that:

Pacemaker patients

- Should keep wireless devices at least six inches from the pacemaker.
- Should NOT place wireless devices directly over the pacemaker, such as in a breast pocket, when it is turned ON.

WTR’s evaluation did not identify any risk to bystanders with pacemakers from other persons using wireless devices.

Electromagnetic fields (EMF)

This VTech product complies with all standards regarding electromagnetic fields (EMF). If handled properly and according to the instructions in this user’s manual, the product is safe to be used based on scientific evidence available today.

FCC and IC regulations

FCC Part 15

This equipment has been tested and found to comply with the requirements for a Class B digital device under Part 15 of the Federal Communications Commission (FCC) rules. These requirements are intended to provide reasonable protection against harmful interference in a residential installation. This equipment generates, uses and can radiate radio frequency energy and, if not installed and used in accordance with the instructions, may cause harmful interference to radio communications. However, there is no guarantee that interference will not occur in a particular installation. If this equipment does cause harmful interference to radio or television reception, which can be determined by turning the equipment off and on, the user is encouraged to try to correct the interference by one or more of the following measures:

- Reorient or relocate the receiving antenna.
- Increase the separation between the equipment and receiver.
- Connect the equipment into an outlet on a circuit different from that to which the receiver is connected.
- Consult the dealer or an experienced radio/TV technician for help.

Changes or modifications to this equipment not expressly approved by the party responsible for compliance could void the user’s authority to operate the equipment.

This device complies with Part 15 of the FCC rules. Operation is subject to the following two conditions: (1) this device may not cause harmful interference, and (2) this device must accept any interference received, including interference that may cause undesired operation.

To ensure safety of users, the FCC has established criteria for the amount of radio frequency energy that can be safely absorbed by a user or bystander according to the intended usage of the product. This product has been tested and found to comply with the FCC criteria. The camera unit shall be installed and used such that parts of all persons’ body are maintained at a distance of approximately 8 in (20 cm) or more.

This Class B digital apparatus complies with Canadian requirement: CAN ICES-3 (B)/NMB-3(B)

Industry Canada

This device complies with Industry Canada licence-exempt RSS standard(s).

Operation is subject to the following two conditions: (1) this device may not cause harmful interference, and (2) this device must accept any interference, including interference that may cause undesired operation.

The term "IC:." before the certification/registration

number only signifies that the Industry Canada technical specifications were met.

This product meets the applicable Industry Canada technical specifications.

RF radiation exposure statement

The camera unit complies with FCC RF radiation exposure limits set forth for an uncontrolled environment. The camera unit should be installed and operated with a minimum distance of 8 in (20 cm) between the main unit and all persons’ body. Use of other accessories may not ensure compliance with FCC RF exposure guidelines. This transmitter must not be co-located or operating in conjunction with any other antenna or transmitter. This equipment complies also with Industry Canada RSS-210 with respect to Canada’s Health Code 6 for Exposure of Humans to RF Fields.

For cETL compliance only

Mesures de sécurité importantes

Lorsque vous utilisez votre appareil, vous devriez toujours suivre certaines mesures de précaution de base afin de réduire les risques d’incendie, d’électrocution et de blessures corporelles, dont ceux qui suivent:

- Observez toutes les instructions et mises en garde inscrites sur l’appareil.
- L’installation par un adulte est requise.
- Ce moniteur résidentiel est conçu à titre d’aide surveillance. Il ne remplace pas les systèmes de surveillance résidentiels et ne doit pas être utilisé comme tel.
- Ce produit n’est pas conçu pour être utilisé en tant que moniteur médical.
- N’utilisez pas cet appareil près de l’eau ni de toute autre source d’humidité, par exemple, près d’une baignoire, cuve à lessive, évier de cuisine, dans un sous-sol humide ni près d’une piscine, dans un sousol humide ou une douche.
- N’utilisez que les adaptateurs inclus avec ce produit. L’utilisation d’un adaptateur dont la polarité ou la tension serait inadéquate risque d’endommager sérieusement le produit et mettre votre sécurité en péril. Adaptateur secteur de la caméra : Entrée 100-240V CA 400 mA 50/60 Hz; Sortie : 5 V CC 2000 mA.
- Lorsqu’ils sont branchés dans une prise de courant, les adaptateurs secteur ont été conçus pour être orientés correctement, soit à la verticale ou au plancher. Les broches n’ont pas été conçues pour supporter le poids du bloc d’alimentation et le maintenir en place si celui-ci est branché dans une prise au plafond, sous une table ou dans un meuble.
- Débranchez ce produit de la prise de courant avant de procéder au nettoyage. N’utilisez pas de nettoyants en aérosols. Utilisez un chiffon humide pour le nettoyer.
- Débranchez les cordons d’alimentation avant de remplacer le bloc-piles.
- Ne coupez pas les cordons d’alimentation pour remplacer les fiches, car ceci peut présenter un danger potentiel.
- Ne laissez aucun objet reposer ni appuyer sur le cordon d’alimentation. N’installez pas cet appareil dans un endroit où l’on risque d’écraser le cordon d’alimentation ou de le piétiner.
- Ne faites fonctionner cet appareil qu’avec le type d’alimentation indiqué sur l’étiquette. Si vous ne connaissez pas le type d’alimentation que

vous possédez à votre domicile, consultez votre marchand ou votre compagnie locale d’électricité.

- Ne surchargez pas les prises de courant murales ni les rallonges électriques.
- Ne placez pas cet appareil sur un chariot, meuble, trépied, support de montage ni table chancelants.
- Les trous et ouvertures du boîtier, situés à l’arrière de l’appareil ou sous celui-ci, servent à aérer l’appareil. Pour l’empêcher de surchauffer, ne bloquez sous aucun prétexte ces ouvertures et n’empêchez pas l’aération adéquate de l’appareil en le plaçant sur un lit, divan, tapis ou toute autre surface similaire. De même, ne le positionnez pas à proximité ni au-dessus d’une source de chaleur ou d’un calorifère. De plus, ne placez pas l’appareil dans un endroit avant de vous assurer qu’il y ait une bonne circulation d’air.
- N’enfoncez jamais d’objets à travers les ouvertures de cet appareil, car ils pourraient entrer en contact avec des points de tension dangereux ou causer des courts-circuits qui peuvent dégénérer en incendies ou en risques d’électrocution. Ne renversez jamais de liquide dans ce produit.
- Afin de réduire les risques d’électrocution, ne démontez pas cet appareil, mais apportez-le dans un centre de service autorisé. L’ouverture du boîtier ou le retrait de toutes pièces que contient cet appareil, à l’exception de l’accès autorisé à certaines portes ou ouvertures, risque de vous exposer à des points de tension dangereux ou d’autres dangers. Un remontage incorrect peut par la suite présenter des risques d’électrocution.
- Vous devriez tester la réception chaque fois que vous mettez l’appareil en fonction.
- Examinez les composantes afin de vérifier si celles-ci ne sont pas endommagées.
- Soyez avisé de la perte de la confidentialité lorsque vous utilisez les ondes publiques. Les conversations peuvent être entendues par d’autres moniteurs de bébé, des téléphones sans fil, des scanners, etc.
- Les enfants devraient être supervisés afin de vous assurer qu’ils ne jouent pas avec l’appareil.
- Les petites pièces de ce moniteur peuvent être avalées par les bébés ou les petits enfants. Veuillez tenir ces pièces hors de portée des enfants.
- Le produit n’est pas conçu pour être utilisé par des personnes (incluant des enfants) aux capacités physiques, sensorielles ou mentales réduites ou qui manquent d’expérience et de connaissances, à moins qu’on leur ait donné suffisamment de supervision ou d’instructions relativement à l’utilisation de l’appareil par une personne responsable de leur sécurité.

CONSERVEZ CES INSTRUCTIONS

Mises en garde

- Utilisez et entreposez le produit à une température entre 0° C (32°F) et 40° C (104° F).
- N'exposez pas cet appareil à des froids ou des chaleurs extrêmes, ainsi qu'à la lumière directe du soleil. Ne l'installez pas près d'une source de chauffage.
- D'autres produits électroniques peuvent causer des interférences auprès de votre caméra IP. Essayez d'installer votre caméra IP le plus loin possible de ces dispositifs électroniques : routeurs sans fil, radios, téléphones cellulaires, interphones, moniteurs de pièces, téléviseurs, ordinateurs personnels, appareils électriques de cuisine et téléphones sans fil.

Stimulateurs cardiaques implantés dans l'organisme

Les simulateurs cardiaques (ne s'applique qu'aux dispositifs numériques sans fil):

L'organisme 'Wireless Technology Research, LLC (WTR)' une firme de recherche indépendante, a mené une évaluation pluridisciplinaire des interférences entre les téléphones sans fil portatifs et les stimulateurs cardiaques implantés dans l'organisme. Appuyée par l'Administration des aliments et drogues (FDA) des États-Unis, la firme WTR recommande aux médecins:

Avis aux détenteurs de stimulateurs cardiaques

- Vous devriez maintenir les dispositifs sans fil à au moins six pouces du simulateur cardiaque.
- Ils ne doivent PAS placer le téléphone sans fil directement sur le stimulateur cardiaque, tel que dans une poche de chemise, lorsque celui-ci est en marche.

L'étude effectuée par l'organisme WRS n'a pas identifié de risque pour les détenteurs de simulateurs cardiaques causés par les gens qui utilisent des dispositifs sans fil à proximité de ceux-ci.

Champs électromagnétiques (EMF)

Ce produit de VTech est conforme à toutes les normes se rapportant aux champs électromagnétiques (EMF) standard. Si vous le manipulez correctement en suivant les instructions de ce guide, son utilisation sera sécuritaire pendant de nombreuses années, selon les meilleures évidences scientifiques dont nous disposons aujourd'hui.

Technical specifications	
Frequency control	Crystal controlled PLL synthesizer control
Transmit frequency	Camera unit: 2412 - 2462 MHz
Channels	11
Nominal effective range	Maximum power allowed by FCC and IC. Actual operating range may vary according to environmental conditions at the time of use.
Power requirement	Camera unit power adapter: Input: 100-240V AC 400mA 50/60Hz Output: 5V DC 2000mA

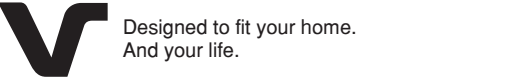

VTech Communications, Inc. A member of THE VTECH GROUP OF COMPANIES. VTech is a registered trademark of VTech Holdings Limited. Specifications are subject to change without notice. © 2014 VTech Communications, Inc. All rights reserved. 07/14_VC931_CIB_V1.0 Document order number: 91-007917-010-100

