

For the installer

Instructions for installation and servicing ecoTEC plus



Wall hung open vent condensing boiler

Contents

1	Introduction	3	3.16	Water pressure loss.....	15
1.1	Notes on the documentation.....	3	3.17	Open vented heating system.....	16
1.1.1	Other instructions supplied with this appliance...	3	3.18	Sealed water systems.....	16
1.1.3	Safety instructions and symbols.....	3	3.18.1	Safety valve.....	16
1.2	Validity of the manual.....	4	3.18.2	Expansion vessel.....	16
1.3	ecoTEC plus boilers.....	4	3.18.3	Pressure gauge.....	16
1.4	Intended use.....	4	3.18.4	Water make up.....	16
1.5	General information.....	4	3.18.5	Filling a sealed water system.....	17
1.5.1	Gas category.....	4	4	Boiler installation sequence	18
1.5.2	Gas safety (installation and use) regulations..	4	4.1	Boiler location.....	18
1.5.3	Gas testing and certification.....	4	4.1.1	Sheet metal parts.....	18
1.5.4	Control of substances hazardous to health...	5	4.1.2	Clearances.....	18
1.5.5	Insulation pads.....	5	4.1.3	Timber frame buildings.....	18
1.5.6	Spare parts.....	5	4.1.4	Contents included with delivery.....	18
1.5.7	Manual handling guidance.....	5	4.2	Flue exit.....	19
1.5.8	Gas leak or fault.....	5	4.2.1	Other flue options.....	19
1.5.9	Clearances.....	5	4.3	Fitting the boiler hanging bracket.....	19
1.5.10	Sheet metal parts.....	5	4.3.1	Boiler fixing.....	19
1.5.11	Sealed components.....	5	4.3.2	Removing the front casing.....	19
1.5.12	Electrical supply failure.....	5	4.3.3	Gas connection.....	19
1.5.13	Protection against freezing.....	5	4.3.4	Water connections.....	20
1.5.14	Boilers installed in a compartment or cupboard.....	5	4.3.5	Condensate trap and siphonic drain connection.....	20
1.5.15	Boiler casing.....	6	4.3.6	Installing the flue system.....	21
1.5.16	Condensate drain.....	6	4.4	Electrical connections.....	21
1.5.17	Plumbing from flue terminal.....	6	4.4.1	Connection to the main supply.....	21
1.5.18	Cleaning.....	6	4.4.2	Wiring system.....	22
1.5.19	Maintenance and servicing.....	6	4.4.3	Electrical board layout.....	23
1.5.20	Technical data.....	6	4.4.4	Controls.....	25
1.6	Statutory requirements.....	6	4.4.5	External electrical controls.....	25
1.7	Regulations, rules and guidelines.....	6	4.4.6	Connection details for external switches and boiler terminal strip.....	26
1.8	CE label.....	7	4.4.7	Vaillant optional plug in timer accessories.....	26
1.9	Benchmark.....	7	4.4.8	Connection details using the VR 65 and VR 61 control centre.....	26
1.10	Gas council numbers.....	7	5	Commissioning (Part I)	27
2	Boiler specifications	8	5.1	Preliminaries - all systems.....	27
2.1	Technical data.....	8	5.1.1	Gas supply.....	27
2.1.2	Dimensions.....	9	5.1.2	Gas pressure statement - Natural gas.....	28
2.1.3	Installation.....	9	5.1.3	Initial Lighting.....	28
3	General requirements	10	5.1.4	Ignition problems.....	29
3.1	Preliminary remarks.....	10	5.1.5	Flue problems.....	29
3.2	Related documents.....	10	5.1.6	Testing - gas.....	29
3.3	Installation site.....	10	6	Natural gas to LPG conversion	30
3.4	Gas supply.....	11	7	Functional checks commissioning (part II) ..	31
3.5	Flue options.....	11	7.1	Functional checks.....	31
3.5.1	Flue termination.....	12	7.2	Heating.....	31
3.5.2	Internal flue installation.....	13	7.3	Domestic hot water (If optional VR65, uniSTOR cylinder and Vaillant control are installed).....	31
3.6	Air supply.....	13	7.4	Pump exercise programme.....	31
3.7	Cupboard or compartment ventilation.....	13	7.5	Final flush of the heating system (hot).....	31
3.8	Domestic hot water cylinder.....	13	7.6	Handing over to the user.....	32
3.8.1	Unvented hot water cylinder.....	13			
3.9	Condensate drain.....	13			
3.10	Heating system controls.....	13			
3.11	Draining tap.....	13			
3.12	Safety valve.....	13			
3.13	Bypass.....	13			
3.14	Pump specification.....	13			
3.15	Cleanser and inhibitor.....	14			

8	Inspection and maintenance	32
8.1	Inspection and maintenance intervals	32
8.1.1	General inspection and maintenance instructions	33
8.1.2	Maintenance	33
8.1.3	Checking the CO/CO ₂ ratio	33
8.1.4	General	35
8.1.5	Spark electrode	36
8.1.6	Removing the burner	36
8.1.7	Combustion chamber and heat exchanger	37
8.1.8	Condensate drain	37
8.1.9	Inner casing panel seal check	37
8.1.10	Checking the expansion vessel (if fitted)	37
8.1.11	Re commissioning the boiler	38
8.1.12	Test operation	38
9	Combustion analysis	38
9.1	Check CO ₂ content	38
10	Troubleshooting	40
10.1	Logical fault finding procedure	40
10.1.1	Status codes	40
10.1.2	Diagnostic codes	40
10.1.3	Fault codes	43
10.1.4	Fault memory	43
10.2	Test programs	44
10.3	Resetting parameter to factory settings	44
11	Parts replacement	45
11.1	Safety instructions	45
11.2	Replacing the burner	45
11.3	Replacing the gas valve	45
11.4	Replacing the fan	45
11.5	Replacing the heat exchanger	45
11.6	Replacing the condense trap and siphonic drain	46
11.7	Replacing electronics and display	46
12	Recycling and disposal	47
12.1	Appliance	47
12.2	Packaging	47
13	Factory guarantee and Vaillant service	47
13.1	Factory guarantee	47
13.2	Vaillant service	47
14	Appendix	48

1 Introduction

1.1 Notes on the documentation.

To ensure clarity of information in instructions a new European standard of advice and symbols is being introduced. To ensure compliance with this new standard the following details are included. The following information is intended to help you through-out the boilers entire instruction pack. We assume no liability for any damage caused by non-observance of these instructions.

1.1.1 Other instructions supplied with this appliance.

For the owner:

Instructions for use	no. 0020020829
Short operating instructions	no. 838404
Warranty card with return envelope	no. 802922

For the installer/service engineer:

Flue installation instructions	no. 834449
--------------------------------	------------

The instructions for any accessories and controllers used also apply.

The Benchmark gas boiler commissioning checklist (in this manual) should be completed by the installer and/or the commissioning engineer.

If, after reading these instructions, you have any questions on the operation of the boiler, please contact either your installer or Vaillant Technical Department.

1.1.2 Retention of documents

Please retain this literature and all related documents so that they are available whenever they are required. If you move please pass on the documents to the buyer.

1.1.3 Safety instructions and symbols

Please observe the safety instructions in this literature for the operation of the appliance.



Danger!

Immediate risk of serious injury or death.



Danger!

Risk of death from electric shock!



Danger!

Risk of burns or scalding!



Caution!

Potentially dangerous situations for the product and environment.



Note!

Useful information and instructions.

- Symbol for a necessary task

1 Introduction



Note!

Installation and adjustment of the boiler as well as service, maintenance and repair may only be carried out by a competent person approved at the time by the Health and Safety executive and in accordance with the gas safety (installation and use) regulations 1998.

1.2 Validity of the manual

This installation manual applies exclusively to units with the following part numbers:

- 0010002460
- 0010002461
- 0010002724
- 0010002725

The part number of the unit can be obtained from the identification plate.

1.3 ecoTEC plus boilers

The ecoTEC plus boilers are designed to provide central heating from a fully pumped open-vented or sealed water system. The central heating water temperature can be adjusted on the boiler. The domestic hot water can only be adjusted on the boiler if it is installed with a Vaillant uniSTOR unvented cylinder and relevant controls. Once the controls are set the boiler operates automatically.

A frost protection programme is also included.

Please read these instructions and follow them carefully for the correct and economical use of your boiler. These instructions are applicable to the following ecoTEC plus boilers, available in Natural Gas. All ecoTEC plus boilers can be converted to LPG.

Appliance	Maximum output
ecoTEC plus 415	15 kW
ecoTEC plus 418	18 kW
ecoTEC plus 428	28 kW
ecoTEC plus 438	38 kW

1.4 Intended use

The boiler has been designed for use with an open-vented central heating system, and comes fully tested and assembled. The boiler is easily mounted on any internal wall and can be installed with either a horizontal or vertical RSF (room sealed fan assisted) flue. The boiler uses a standard flue system (100 mm or 125 mm outside diameter). Flue extensions and additional bends and elbows are available for the flue system to increase the flexibility. If desired, an inhibitor may be used in the system. Guidance on the use of inhibitors is contained in these instructions. The boiler has a built-in diagnostic system which indicates the operational status of the boiler. This feature provides key information to aid commissioning and fault finding. The data badge is fitted to

the combustion chamber cover of the boiler. See text of General Requirements for installation requirements or notes.

The Vaillant ecoTEC plus boiler is a state-of-the-art appliance which has been constructed in accordance with recognised safety regulations. Nevertheless, danger to the life and limb of the user or third parties can still occur or the appliance or other material assets be impaired in the event of improper use.

The unit is not intended for use by persons (including children) with reduced physical, sensory or mental capabilities, or lack of experience and/or knowledge, unless they have been given supervision or instruction concerning use of the unit by a person responsible for their safety.

Children must be watched to ensure that they do not play with the unit.

The appliances are designed for central heating systems. Any other use or extended use is considered to be use other than intended. The user alone bears the risk. The manufacturer/ supplier is not liable for any resulting damage. Intended use includes the observance of the operating and installation manual and the adherence to the inspection and maintenance conditions.



Caution!

Any incorrect use is forbidden. The appliances must be installed by a competent person approved at the time by the Health and Safety Executive, who is responsible for adhering to the existing regulations, rules and guidelines.

1.5 General information

Thank you for choosing a Vaillant boiler. The information given in this booklet will enable you to obtain the best performance from this boiler.

1.5.1 Gas category

The boiler is supplied factory set for use on Natural Gas (G20). The ecoTEC plus boilers can be field adjusted for use on LPG (propane G31), see section 6 for instructions or contact Vaillant Service, 0870 6060 777.

1.5.2 Gas safety (installation and use) regulations

In your own interests and that of safety, it is the Law that ALL gas appliances are installed by a competent person approved at the time by the Health and Safety Executive in accordance with the current issue of the above regulations.

1.5.3 Gas testing and certification

The boiler is tested and certificated for safety and performance. It is, therefore, important that no alteration is made to the boiler.

1.5.4 Control of substances hazardous to health

Under Section 6 of The Health and Safety at Work Act 1974, we are required to provide information on substances hazardous to health. The adhesives and sealants used in this appliance are cured and give no known hazard in this state.

1.5.5 Insulation pads

These can cause irritation to skin, eyes and the respiratory tract. If you have a history of skin complaint you may be susceptible to irritation. High dust levels are usual only if the material is broken. Normal handling should not cause discomfort, but follow normal good hygiene and wash your hands before eating, drinking or going to the lavatory. If you do suffer irritation to the eyes or severe irritation to the skin seek medical attention.

1.5.6 Spare parts

Only original Vaillant spare parts may be used.

1.5.7 Manual handling guidance

During the appliance installation (and any subsequent replacement of the heat exchanger) it will be necessary to employ caution. All installers and operatives involved from unloading the appliance until it is fully mounted on the wall in its final installed location must exercise full duty of care for themselves and others with regard to safe lifting and handling of this appliance. Operatives should employ assistance whilst lifting the appliance or components. In certain situations it may be required to use a mechanical handling aid. Take care to avoid trip hazards, slippery or wet surfaces.



Caution!

With regards to the Manual Handling Operations, 1992 Regulations, the following lift operation exceeds the recommended weight for a one man lift.

Employers and installers should refer to the HSE web site for full advice and manual Handling assessment charts (MAC) tool.



Danger!

Smell of gas. Risk of poisoning and explosion due to a malfunction.

1.5.8 Gas leak or fault

If you smell gas or suspect a gas leak:

- Do not switch lights on or off.
- Do not use any other electrical switches.
- Do not use a telephone in the hazardous area.
- Do not use naked flames, such as matches or cigarette lighters.
- Do not smoke.
- Turn off the gas supply at the gas meter.
- Open the windows and doors.
- Warn other residents.

- Get out of the house.
- Consult your gas supplier, service agent or other competent person approved at the time by the Health and Safety Executive.

Telephone the National emergency number 0800 111 99

1.5.9 Clearances

If fixtures are positioned close to the boiler, space must be left as shown in fig 4.1. Enough space must also be left in front of the boiler to allow for servicing.

1.5.10 Sheet metal parts

This boiler contains metal parts (components) and care should be taken when handling and cleaning, with particular regard to edges.

1.5.11 Sealed components

Under no circumstances must the User interfere with any sealed component as this could result in a potentially dangerous situation arising.



Danger!

This boiler must be earthed.

1.5.12 Electrical supply failure

The boiler will not work without an electrical supply. Normal operation of the boiler should resume when the electrical supply is restored. Reset any external controls to resume normal operation of the central heating. If the boiler does not resume normal operation. (The burner fails to ignite after five attempts). The overheat thermostat may have operated. Automatic ignition can only take place after you manually reset the fault, refer to section 5.1.3. to reset.

1.5.13 Protection against freezing

The boiler has a built in frost protection programme as long as the electricity and gas are left switched on. This device operates the burner and system pump when the temperature inside the boiler falls to 3°C. Any other exposed areas of the system should be protected by a separate frost thermostat. If the mains electricity and gas are to be turned off for any long periods during severe weather, it is recommended that the whole system, including the boiler, should be drained to avoid the risk of freezing. Make sure that, if fitted, the immersion heater in the cylinder is switched off. If you have a sealed water system contact your installation/servicing company as draining, refilling and pressurising MUST be carried out by a competent person approved at the time by the Health and Safety Executive.

As a safety feature the boiler will stop working if the condensate drain becomes blocked. During freezing conditions this may be due to the forming of ice in the condensate drain external to the house. Release an ice blockage by the use of warm cloths on the pipe. The boiler should then restart. Contact your installation/servicing company if the fault persists.

1 Introduction

1.5.14 Boilers installed in a compartment or cupboard

If the boiler is fitted into a compartment or cupboard it does not require ventilation openings.
Do not use the compartment or cupboard for storage.

1.5.15 Boiler casing

Do not remove or adjust the casing in any way, as incorrect-fitting may result in incorrect operation or failure to operate at all.

1.5.16 Condensate drain

The condensate drain must not be modified or blocked.

1.5.17 Plumbing from flue terminal

All condensing boilers produce a plume of water vapour from the flue terminal. This is due to the high efficiency and hence low flue gas temperature. This may increase in wet, damp weather but this is completely normal and indicates that the boiler is operating correctly.

1.5.18 Cleaning

This appliance contains metal parts and care should be taken when handling and cleaning with particular regard to edges. The boiler casing can be cleaned using a mild liquid detergent with a damp cloth, then a dry cloth to polish. Do not use any form of abrasive or solvent cleaner as you may damage the paint work.

1.5.19 Maintenance and servicing

For the continued efficient and safe operation of the boiler it is recommended that it is checked and serviced at regular intervals. The frequency of servicing will depend upon the installation conditions and usage, but in general, once a year should be enough.

If this appliance is installed in a rented property there is a duty of care imposed on the owner of the property by the current issue of the Gas Safety (Installation and Use) Regulations, Section 35. Servicing/maintenance should be carried out by a competent person approved at the time by the Health and Safety Executive in accordance with the rules in force in the countries of destination.

Please be advised that on completion of commissioning and servicing you should complete the Benchmark gas boiler commissioning checklist.

All competent persons approved at the time by the Health and Safety Executive carry a ID card, and have a registration number. Both should be recorded there.

1.5.20 Technical data

All dimensions are given in millimetres (except as noted). The data label is positioned on the combustion chamber cover. The Seasonal Efficiency Domestic Boilers UK (SEDBUK) is: All ecoTEC plus boilers : Class 'A'. The value is used in the UK Government's Standard Assessment Procedure (SAP) for energy rating of dwellings. The test data from which it has been calculated has been certified by B.S.I.

1.6 Statutory requirements

The appliance is suitable only for installation in GB and IE and should be installed in accordance with the rules in force. In GB the installation of the boiler must be carried out by a competent person as described in the following regulations:

- The manufacturer's instructions supplied
- The Gas Safety (Installation and Use) Regulations
- The appropriate Buildings Regulations either
 - The Building Regulations
 - The Building Regulations (Scotland)
 - The Building Regulations (Northern Ireland)
- The Water Fittings Regulations or Water bye laws in Scotland
- The Health and Safety at Work Act, Control of Substances Hazardous to Health (COSHH)
- The Current I.E.E. Wiring Regulations

Where no specific instructions are given, reference should be made to the relevant British Standard Code of Practice. In IE, the installation must be carried out by a competent person and installed in accordance with the current edition of I.S.813 "Domestic Gas Installations", the current Building Regulations and reference should be made to the current ETCI rules for Electrical Installation.

In GB the following Codes of Practice apply:

BS 4814,	BS 6891
BS 6798	BS 6700
BS 5440 Part 1 and 2	BS 7074 Part 1 and 2
BS 5546 Part 1	BS 7593
BS 5449	BS 7671

In IE:

I.S.813	BS 5546
BS 7074	BS 5449
BS 7593	

Manufacturer's instructions must not be taken as overriding statutory requirements.



Note!

For further information, see the current issue of the Building Regulations, approved document L1 (in the UK) and the current issue of the following:

- **Central heating system specification (CheSS)**
- **Controls for domestic central heating system and hot water (BRECSU).**

Certification

This boiler certificated to the current issue of EN 483 for performance and safety. It is important that no alteration is made to the boiler, without permission, in writing, from Vaillant. Any alteration that is not approved by Vaillant, could invalidate the warranty and could also infringe the current issue of the Statutory Requirements.

1.7 Regulations, rules and guidelines.

This boiler meets the requirements of Statutory Instrument, No. 3083 The Boiler (Efficiency) Regulations, and therefore is deemed to meet the requirements of Directive 92/42/EEC on the efficiency requirements for new hot water boilers fired with liquid or gaseous fuels. Type test for purposes of Regulation 5 certified by: Notified body 0087. Product/production certified by: Notified body 0086.

1.8 CE label



The CE label on this appliance shows compliance with:

- Directive 90/396/EEC on the approximation of the laws of the Member States relating to appliances burning gaseous fuels.
- Directive 73/23/EEC on the harmonisation of the Laws of the Member States relating to electrical equipment designed for use within certain voltage limits.
- Directive 89/336/EEC on the approximation of the Laws of the Member States relating to electromagnetic compatibility.
- Directive 92/42/EEC on the efficiency requirements.

1.9 Benchmark



Note!

Vaillant Ltd. support the Benchmark initiative
At the rear of the installation manual, you will find a Benchmark gas boiler commissioning checklist. It is very important that this is completed correctly at the time of installation, commissioning and hand over to the user.



1.10 Gas council numbers

Appliance	Gas council numbers
ecoTEC plus 415	41 - 044 - 53
ecoTEC plus 418	41 - 044 - 54
ecoTEC plus 428	41 - 044 - 55
ecoTEC plus 438	41 - 044 - 57

2 Boiler specifications

2 Boiler specifications

2.1 Technical data

Description	ecoTEC plus 415	ecoTEC plus 418	ecoTEC plus 428	ecoTEC plus 438	Unit
Maximum CH heat input (net)	15.3	18.9	28.6	38.4	kW
CH heat output (80/60 °C)	5.0 - 15.0	5.0 - 18.6	5.3 - 28.2	6.3 - 38.0	kW
CH heat output (50/30 °C)	5.3 - 16.2	5.3 - 20.0	5.7 - 30.6	6.8 - 41.0	kW
SEDBUK Band	A	A	A	A	
SAP Seasonal Efficiency	90.5	90.4	90.6	90.8	%
NOx Class	5	5	5	5	
IP rating	IPX4D	IPX4D	IPX4D	IPX4D	
Inlet gas working pressure required (natural gas)	20	20	20	20	mbar
Gas supply (G20) Gross CV (s.t.)	37.8	37.8	37.8	37.8	MJ/m ³
Maximum gas rate	1.61	2.0	3.02	4.06	M ³ /h
Minimum gas rate	0.53	0.53	0.56	0.71	M ³ /h
Burner % CO ₂ (Case on)	9.3 + 0.2 - 0.5	9.3 + 0.2 - 0.5	9.3 + 0.2 - 0.5	9.0 + 0.2 - 0.5	%
Gas connection (compression)	15	15	15	15	mm
Water connections (compression)	22	22	22	22	mm
Condensate drain (internal diameter)	19 min.	19 min.	19 min.	19 min.	mm
Main PCB	2	2	2	2	A
Minimum flow rate of water through the boiler	10.8	12.9	20.3	27.2	L/min.
Weight	31	31	33	33	kg
Electrical supply	230/~50	230/~50	230/~50	230/~50	V~/HZ
External fuse	3	3	3	3	A
Power input	60	60	60	60	W
Flue categories	C13, C33, C43, C53	C13, C33, C43, C53	C13, C33, C43, C53	C13, C33, C43, C53	
Case height	600	600	600	600	mm
Case width	375	375	375	375	mm
Case depth	340	340	340	340	mm

2.1.2 Dimensions

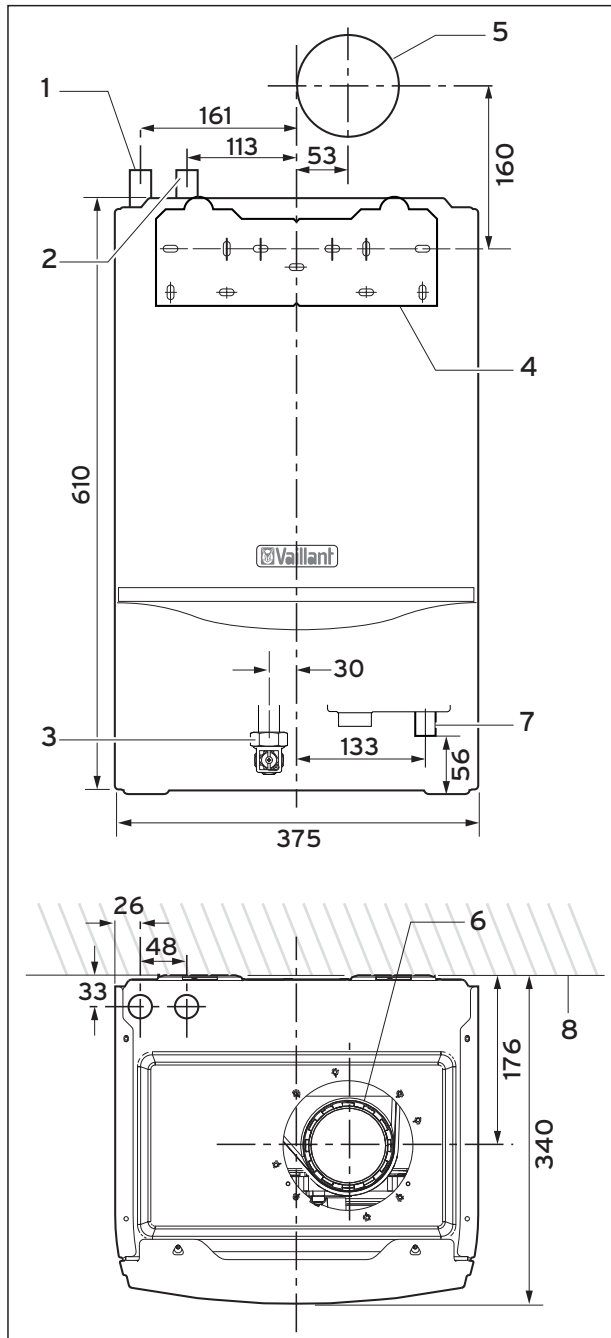

Fig. 2.1 Dimensions in mm

- 1 Heating return pipe \varnothing 22
- 2 Heating flow pipe \varnothing 22
- 3 Gas connection \varnothing 15
- 4 Hanging bracket
- 5 Flue hole - flue system 303 933
- 6 Flue pipe connection
- 7 Condensate drain outlet connection (\varnothing 21)
- 8 Outside wall face

2.1.3 Installation

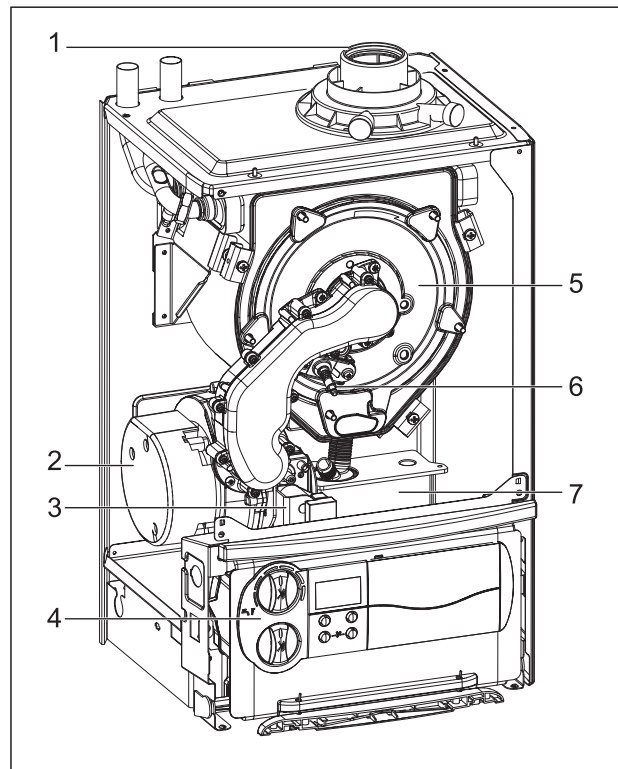

Fig. 2.2 Function elements of boiler

- 1 Flue pipe connection
- 2 Fan
- 3 Gas valve
- 4 Electronics box
- 5 Burner module
- 6 Ignition electrode
- 7 Condense trap

3 General requirements

3 General requirements

3.1 Preliminary remarks

This appliance must only be installed and commissioned by a suitably competent person. Please check with your installer that he is able to carry out all the necessary works including official notification of the works to the relevant body upon completion.

3.2 Related documents

The installation of the appliance and any associated hot water system must be in accordance with (but not limited to) the following; COSHH regulations, Gas Safety (Installation and Use) Regulations 1998, Health and Safety Document No. 635 (The Electricity at Work Regulations 1989), BS7671 (IEE Wiring Regulations) and the Water Supply (Water Fitting) Regulations 1999, or The Water Bylaws 2000 (Scotland). It should also be in accordance with the relevant requirements of the Local Authority, Building Regulations, The Building Regulations (Scotland), The Building Regulations (Northern Ireland) and the relevant recommendations of the following British Standards:

BS 6700: Services supplying water for domestic use within buildings and their curtilages.

BS 6798: Specification for installation of gas fired boilers not exceeding 60 kW input.

BS 6891: Specification for installation of low pressure gas pipework up to 35 mm (R1) in domestic premises (2nd family gas).

BS 7593: Treatment of water in domestic hot water central heating systems.

Institute of Gas Engineers Publication **IGE/UP/7/1998:** "Guide for gas installations in timber framed housing"

BS. 5482 Pt. 1: Domestic butane and propane gas burning installations.

IGE/UP1: Soundness testing and purging of industrial and commercial gas installation.

IGE/UP1B (Edition 2): Tightness testing and direct purging of small natural gas installations. For larger installation sites consider also IGE/UP1A.

IGE/UP2: Gas installation pipework, boosters and compressors on industrial and commercial premises.

IGE/UP10: Installation of gas appliances in industrial and commercial premises.

BS. 6644: Installation of gas fired hot water boilers of rated inputs between 60 kW and 2 MW (2nd and 3rd family gases).

BS. 5449: Forced circulation hot water central heating systems for domestic premises. Note: only up to 45 kW.

BS. 6880: Low temperature hot water heating systems of output greater than 45 kW.

Part 1 Fundamental and design considerations.

Part 2 Selection of equipment.

Part 3 Installation, commissioning and maintenance.

BS. 4814: Specification for: Expansion vessels using an internal diaphragm, for sealed hot water heating systems.

BS. 5440: Installation and maintenance of flues and ventilation for gas appliances of rated input not exceeding 70 kW net (1st, 2nd and 3rd family gases).

Part 1 Specification for installation of flues.

Part 2 Specification for installation and maintenance of ventilation for gas appliances.



Caution!

The appliance must be installed and serviced by a competent person approved at the time by the Health and Safety Executive as stated in the Gas Safety (Installation and Use) Regulations 1998. In IE, the installation must be in accordance with the current edition of I.S.813 'Domestic Gas Installations', the current Building Regulations and reference should be made to the current ETCI rules for electrical installation.



Caution!

When tightening or slackening screwed connections always use suitable open-ended spanners (not pipe wrench, or extensions, etc.). Incorrect use and/or unsuitable tools can lead to damage being caused (e.g. gas or water leakage)!

3.3 Installation site

The location chosen for the boiler must permit the provision of a satisfactory flue termination. The location must also provide adequate space for servicing and air circulation around the boiler. The boiler may be installed in any room, although particular attention is drawn to the requirements of BS 7671 (IEE Regulations), the electrical provisions of the Building Standards (Scotland) Regulations, and in IE the current edition of IS 813 and the current ETCI rules, in respect of the installation of a boiler in a room containing a bath or shower.



Note!

If a room sealed boiler is installed in a room with a bath or shower, electrical switches or boiler controls using the mains power supply must be placed at locations that cannot be reached by the person in the bath or shower.

If the boiler is installed in an unusual location, special procedures may be necessary and BS 5546 and BS 6798 give detailed guidance on this aspect. The boiler must be mounted on a flat, vertical wall, which must be sufficiently robust to take the weight of the boiler. The boiler may be installed on a combustible wall, subject to the requirements of the Local Authorities and Building Regulations. A compartment used to enclose the boiler must be designed and constructed specifically for this purpose. (An existing cupboard or compartment may be used provided that it is modified for the purpose). Details of essential features of cupboard/compartment design including airing cupboard installations are given in BS 6798. If the boiler is to be fitted in a timber framed building, it should be fitted in accordance with Institute of Gas Engineers Publication IG/UP/7 Edition 2 "Gas installa-

tions in timber framed and light steel framed buildings". Please note the safety instructions below before deciding where to install the boiler:

Caution!
Do not install the appliance in rooms prone to frost. In rooms with aggressive steam or dust, the appliance must be operated independent of the ambient air.

When choosing the place of installation and while operating the appliance, make sure that the air supply is free of chemical substances containing fluorine, chlorine, sulphur etc. Sprays, solvents and cleaning agents, paints, adhesives etc. contain the kind of substances that can lead to corrosion even in the exhaust system when the appliance is operated depending on the ambient air in the worst case scenario. Particularly in hair-cutting salons, lacquering and finishing, cleaning facilities, the appliance must be operated independent of the ambient air! Otherwise, a separate installation room is required to guarantee that the air supply is free of the above mentioned substances.

3.4 Gas supply

The gas supplier should ensure the availability of an adequate supply of gas. A gas meter may only be connected to the service pipe by the supplier of gas or their contractor. An existing meter should be checked to ensure that it is capable of passing the rate of gas supply required. Installation pipes should be fitted in accordance with BS 6891. In IE the current edition of IS 813. Pipe work from the meter to the boiler must be of an adequate size. Do not use pipes of a smaller size than the boiler gas connection (15 mm). The complete installation must be checked for leaks and purged as described in BS 6891.

Danger!
Vaillant appliances are certified only for use with genuine Vaillant flue pipes. Only use genuine Vaillant flue pipes. Malfunctions can occur if you use other accessories. These may result in damage and injury. You will find a list of genuine flue pipes in the Vaillant installation manual for flue pipes. The CE mark is valid only if the appliance is operated with Vaillant flue pipes.

3.5 Flue options

There are various flue systems to choose from, as follows:
 60/100 standard horizontal air/flue duct, see fig 3.1.
 60/100 telescopic horizontal air/flue duct, see fig 3.2.
 60/100 Vertical air/flue duct and terminal, see fig 3.3.
 80/125 horizontal air/flue duct, see fig 3.4.
 80/125 Vertical air/flue duct and terminal, see fig 3.5.
 Flue extensions are available to extend the length, both 90° bends and 45° elbows are also available. Refer to flue system installation instructions for full details.
 When extension pipes are used the flue system must be designed to have a continuous fall to the boiler of at least 3° to allow condensate to run out via the drain.

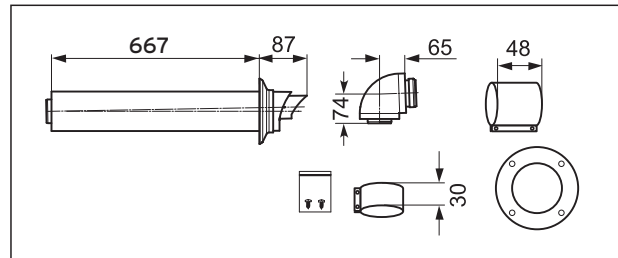

Fig. 3.1 Art. No. 30 39 33

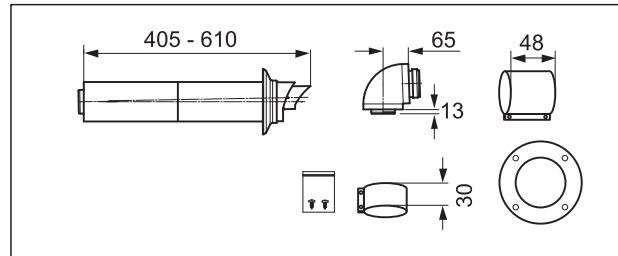

Fig. 3.2 Art. No. 30 39 36

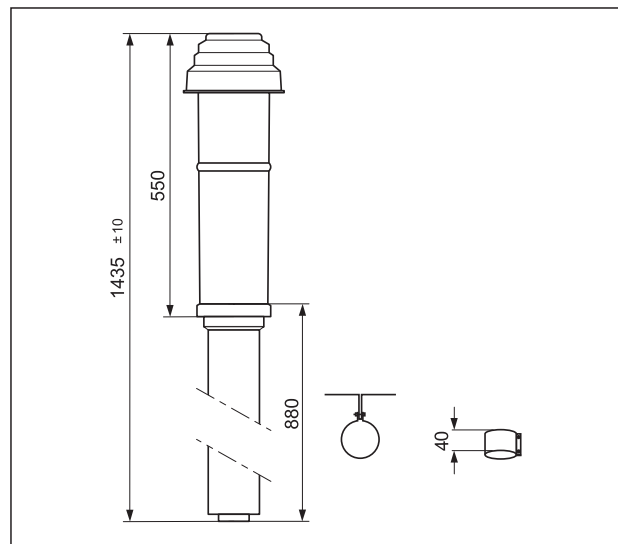

Fig. 3.3 Art. No. 30 39 00

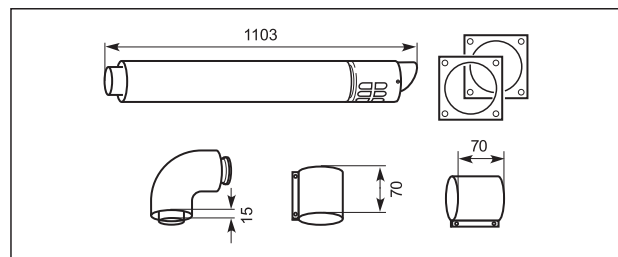

Fig. 3.4 Art. No. 30 32 09

3 General requirements

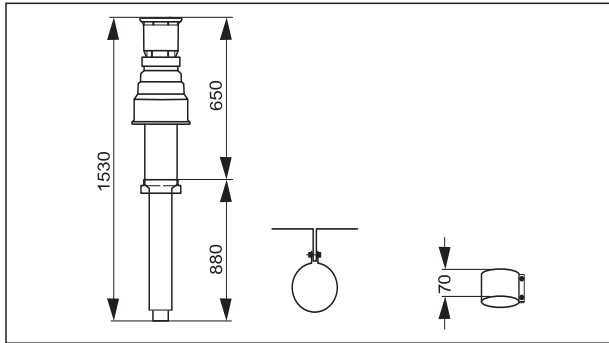

Fig. 3.5 Vertical Flue System Art. No. 30 32 00

3.5.1 Flue termination

The following details refer to both flue systems.

- The terminal must be located where the combustible substances can escape freely at all times.
- A plume of water vapour will sometimes be visible from the flue terminal. Positions where this could be a nuisance should be avoided.
- If the terminal is fitted less than 2 m above a balcony, above ground or above a flat roof to which people have access then a suitable terminal guard must be provided and fitted (made by Tower Flue Components, Tonbridge, TN9 1TB, Model K3, plastic coated).

Note!
Vertical flues must not terminate within 600mm of an openable window, air vent or any other ventilation opening.

The flue assembly shall be so placed or shielded as to prevent ignition or damage to any part of the building.

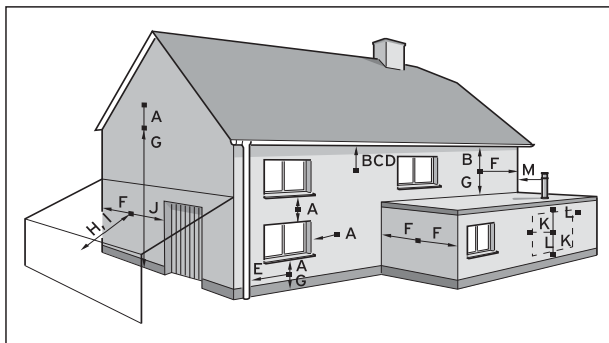

Fig. 3.6 Terminal locations

Note!
Vertical flues must not terminate within 600mm of an openable window, air vent or any other ventilation opening.

	Terminal position	mm
A	Directly below an opening, above an opening or horizontal to an opening, air brick, opening window, etc.	300
B	Below gutters, soil pipes or drain pipes	75
C	Below eaves	200
D	Below balconies	200
E	From vertical drain pipes and soil pipes	25
F	From internal or external corners	300
G	Above ground, roof or balcony	300
H	From a surface facing a terminal	600
I	From a terminal facing a terminal	1200
J	From an opening in the car port (e.g. door, window) into the dwelling	1200
K	Vertically from a terminal on the same wall	1500
L	Horizontally from a terminal on the same wall	300
M	Distance from adjacent wall for vertical Flue	500

Table 3.1 Flue terminal position for a fan assisted concentric flue

The flue assembly shall be so placed or shielded as to prevent ignition or damage to any part of the building.

Note!
In addition, the terminal should not be located closer than 150 mm from a wall opening provided for e.g. a window. Boundary flue terminations must as a minimum comply with Building regulation part „J“ 600 mm and should also be in accordance with the Guide to Condensing Boiler Installation which recommends 2.5 m from wall, fence or boundary.
Where a plume diverter terminal is used this is measured in the direction of the flow of products.

BS 5440-1: It is recommended that the fanned flue terminal should be positioned as follows:

- at least 2 m from an opening in the building directly opposite, and
 - so that the products of combustion are not directed to discharge across a boundary.
- Dimensions B, C and D: These clearances may be reduced to 25 mm without affecting the performance of the boiler. In order to ensure that the condensate plume does not affect adjacent surfaces the terminal should be extended as shown in Fig. 3.7.
 - Dimension F: This clearance may be reduced to 25 mm without affecting the performance of the boiler. However, in order to ensure that the condensate plume does not affect adjacent surfaces a clearance of 300 mm is preferred. For IE, recommendations are given in the current edition of IS 813.

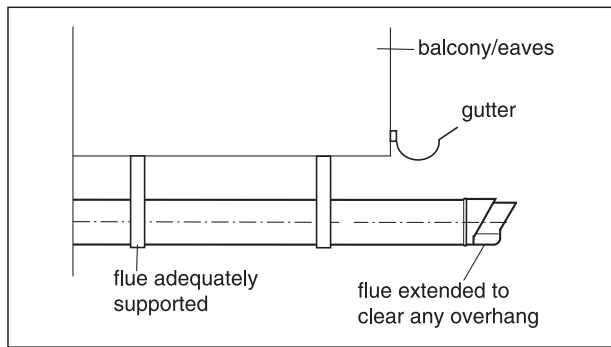

Fig. 3.7 Flue termination under balcony/eaves

3.5.2 Internal flue installation

The flue can be installed from inside the building when access to the outside wall face is not practicable.

3.6 Air supply

Detailed recommendations for air supply are given in BS 5440: Part 2. It is not necessary to have an air vent in the room or internal space in which the boiler is installed.

3.7 Cupboard or compartment ventilation

The boilers are very high efficiency appliances. As a consequence the heat loss from the appliance casing during operation is very low. For cupboard or compartment installations it is therefore not necessary to provide any high or low level permanent air vents for cooling purposes.

3.8 Domestic hot water cylinder



Caution!

Single feed indirect cylinders are not suitable. The domestic hot water cylinder must be of the double feed fully indirect coil type. It must be suitable for working at a gauge pressure of 0.35 bar above the safety valve setting.

3.8.1 Unvented hot water cylinder

The ecoTEC plus can be connected to an unvented hot water cylinder. Vaillant offer a range of cylinders called uniSTOR with capacities from 125 litres to 310 litres. All unvented domestic hot water cylinders must be installed by a competent person approved at the time by the Health and Safety Executive to the current building regulations and water regulations at the time of installation.

For building regulations refer to G3 and for water regulations guidance G17 to G24 and recommendation R17 to R24. For Ireland: The current issue of BS5546 and BS6700. If fitting to an existing system the local authority should be informed.

3.9 Condensate drain

A plastic drain pipe must be fitted to allow discharge of condensate to a drain.

Condensate should, if possible, be discharged into the internal household draining system. If this is not practical, discharge can be made externally into the household drainage system or a purpose designed soak away, see Section 4.3.5 for more details.

3.10 Heating system controls

It is recommended that a programmer and room thermostat control the boiler. Vaillant have a range of optional easy fit controls available.

Thermostatic radiator valves must be installed, however they must not be fitted in a room where the room thermostat is located.



Note!

All systems must have at least one radiator not fitted with a thermostatic valve.



Note!

For further information, see the current issue of the Building Regulations, approved document L1, and the following current issues of:

- 1. Central heating system specification (CheSS)**
- 2. Controls for domestic central heating system and hot water (BRECSU).**

3.11 Draining tap

A draining tap must be provided at all the lowest points of the system, which will allow the entire system and hot water system to be drained. Draining taps shall be to the current issue of BS 2879.

3.12 Safety valve

A safety valve need not be fitted to an open-vented system.

3.13 Bypass

A system bypass will be required fitted at least 1.5 metres away from the boiler, refer to the current issue of central heating system specifications (CHeSS).

3.14 Pump specification

The pump should be fitted on the flow pipe from the boiler and have isolating valves each side.

3 General requirements

3.15 Cleanser and inhibitor

In the case of an existing installation, it is essential that prior to installing the new boiler the system is thoroughly flushed. For optimum performance after installation of a new system, the boiler and its associated central heating system should also be flushed. Flushing should be carried out in accordance with BS7593: 1992 using a cleanser. For long-term corrosion protection, after flushing, an inhibitor suitable for stainless steel heat exchangers should be used, refer to the current issue of BS 5449 and BS 7593 on the use of inhibitors in central heating systems.



Caution!

It is essential that the cleanser is fully removed from the system after flushing and before adding inhibitor. Take care to ensure that all low points in the system are fully drained.

Mixing additives with the heating water can result in material damage. However, up to now, no incompatibility with Vaillant appliances has been detected with proper use of the following products.

- When using additives, follow the additive manufacturer's instructions without exception.

Vaillant accepts no liability for the compatibility of any additive or its effectiveness in the entire heating system.

Additives for cleaning purposes (subsequent flushing required)

- Fernox F3
- Jenaqua 400
- Sentinel X 300
- Sentinel X 400

Additives intended to remain permanently in the system

- Fernox F1
- Fernox F2
- Sentinel X 100
- Sentinel X 200

Additives for frost protection intended to remain permanently in the system

- Fernox Antifreeze Alpha 11
- Sentinel X 500

- Inform the operator of the necessary measures in case you have used any of these additives.
- Inform the operator of the required procedures for frost protection.
- Observe the applicable national regulations and technical standards for the treatment of filling and top-up water.

Provided the national regulations and technical standards do not specify any higher requirements, the following applies:

- You must treat the heating water
 - if the total volume of filling and top-up water exceeds thrice the nominal volume of the heating system over the service life of the system
 or
 - if the limits given in the following tables are not adhered to.

Total heating output	Total hardness at 20 l/kW for the smallest boiler heating surface ²⁾	Total hardness at > 20 l/kW < 50 l/kW for the smallest boiler heating surface ²⁾	Total hardness at > 50 l/kW for the smallest boiler heating surface ²⁾
kW	mol/m ³	mol/m ³	mol/m ³
< 50	No requirement or < 3 ¹⁾	2	0,02
> 50 to ≤ 200	2	1,5	0,02
> 200 to ≤ 600	1,5	0,02	0,02
> 600	0,02	0,02	0,02

1) with systems equipped with wall-hung boiler and systems with electric heating elements

2) of the specific system volume (nominal capacity in litres/heating output; in case of multiple boiler systems the lowest individual heating output should be used)

These data only apply up to 3x the system volume for filling and top-up water. Once this triple system volume is exceeded, the water will have to be treated exactly the same as in case of exceeding the limit values given in table 3.3 (softening, desalination, hardness stabilisation and desludging).

Table 3.2 Guidelines for the heating water: Water hardness

Heating water qualities	Unit	Low-salt	saline
Electric conductivity at 25 °C	μS/cm	< 100	100-1500
Appearance		Free of sedimentary substances	
pH-value at 25 °C		8,2-10,0 ¹⁾	8,2-10,0 ¹⁾
Oxygen	mg/L	< 0,1	< 0,02

1) With aluminium and aluminium alloys, the pH value range is restricted from 6.5 to 8.5.

Table 3.3 Guidelines for heating water: Salinity



Caution!

Aluminium corrosion resulting in leakages caused by unsuitable heating water!
 Unlike materials such as steel, cast iron or copper, aluminium is reactive to alkalis heating water (pH-value > 8,5) which results in significant corrosion.

With aluminium, ensure that the pH value of the heating water ranges between 6.5 up to a maximum of 8.5.



Caution!

Risk of material damage if the heating water is treated with unsuitable frost or corrosion protection agents!
 Frost and corrosion protection agents may cause changes in the seals, noises during heating and possibly subsequent damage.
 Do not use any unsuitable frost or corrosion protection agents.

3.16 Water pressure loss

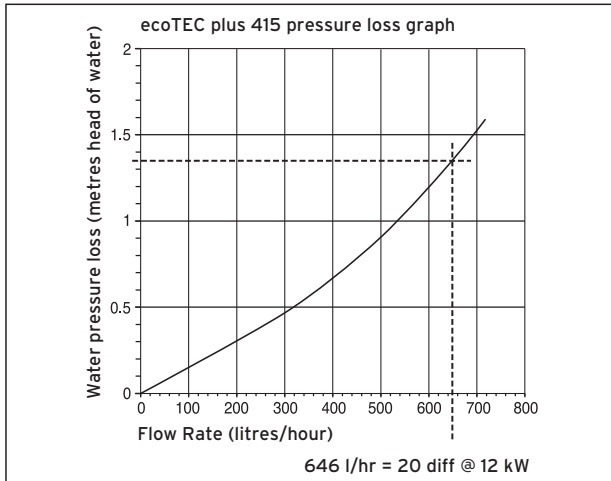

Fig. 3.8.1 Pressure loss ecoTEC plus 415

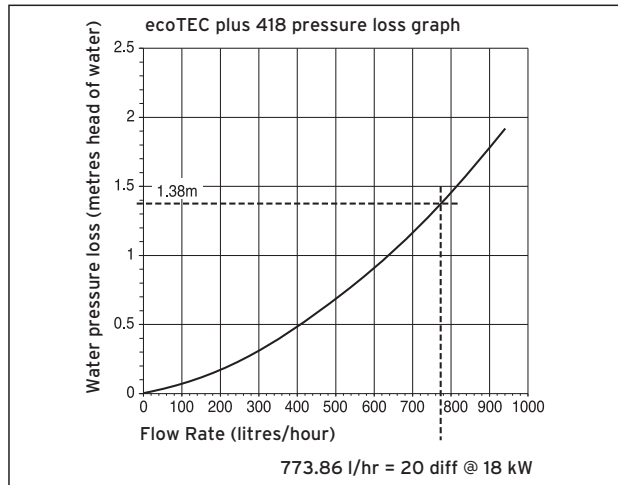

Fig. 3.8.2 Pressure loss ecoTEC plus 418

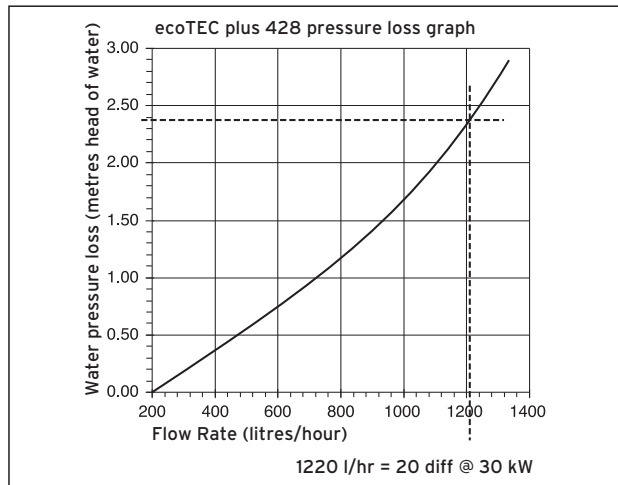

Fig. 3.8.3 Pressure loss ecoTEC plus 428

3 General requirements

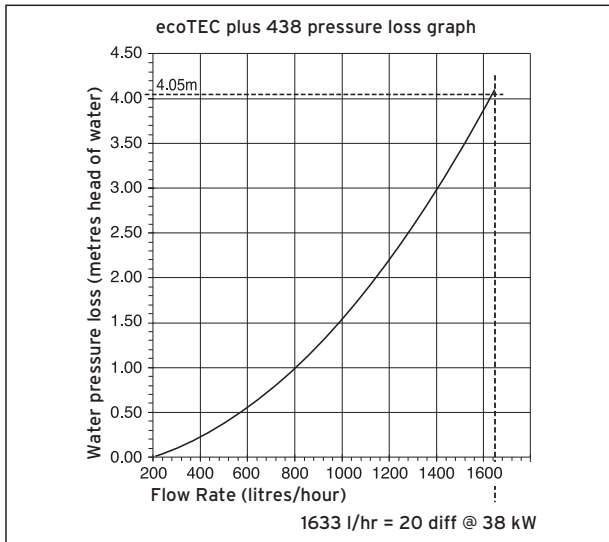

Fig. 3.8.4 Pressure loss ecoTEC plus 438

3.17 Open vented heating system

The boiler must be supplied from an unrestricted water supply taken from a feed and expansion cistern situated at a maximum height of 27 metres (90ft) above the boiler. The cold feed must be 15mm minimum size. The vent must rise continuously and be unrestricted. It is important that the relative positions of the pump, cold feed and open vent are as shown in fig 3.9.

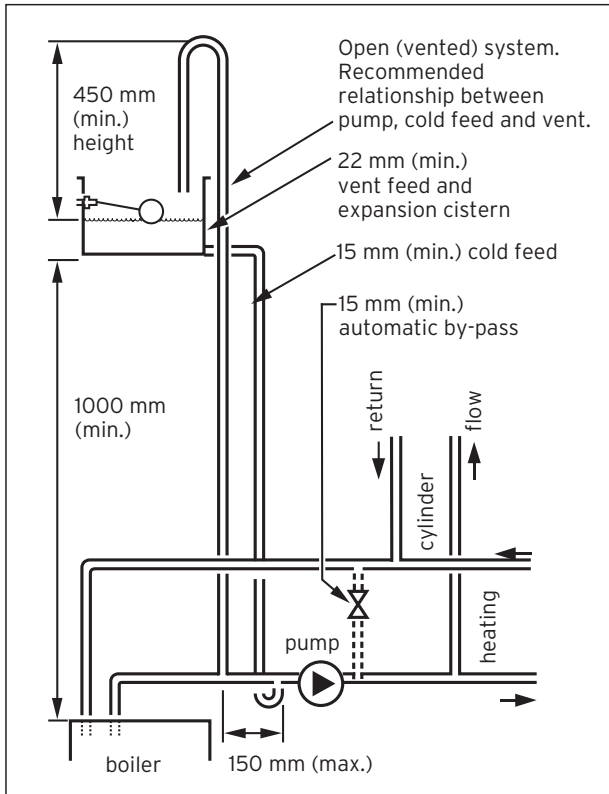

Fig. 3.9 Open vented system

3.18 Sealed water systems

The installation must comply with the appropriate requirements of the current issue of BS4814, BS5449, BS6759, BS6798 and BS7074 Part 1 and 2. For IE your attention is drawn to the current edition of IS 813. It is highly recommend to use the Vaillant Sealed System Kit Article; 020053207 This includes all necessary components and is included in your Vaillant warranty. See also fig 3.10.

3.18.1 Safety valve

A safety valve must be fitted to a sealed system. It shall be preset, non-adjustable with a lift pressure of 3-bar, incorporating seating of a resilient material, a test device and a connection for drain. The safety valve discharge pipe must be routed to outside the building, must not discharge above an entrance or window or any type of public access area, be clear of any electrical fittings and positioned so that any discharge can be seen.

3.18.2 Expansion vessel

A diaphragm type expansion vessel, conforming to the current issue of BS4814 (see also BS7074 Part 1 and 2). For IE the current edition of IS 813, must be connected at a point close to the inlet side of the circulating pump, see the Typical installation, Fig. 3.10. unless laid down differently by the manufacturer. The expansion vessel volume depends on the total water system volume and the initial system design pressure. For any system an accurate calculation of vessel size is given in the current issue of BS5449 and BS7074 Part 1. Example: For an initial design pressure of 0.7 bar, the minimum total vessel volume required is $0.063 \times \text{Total System Volume}$.

Note!

A higher initial design pressure requires a larger volume expansion vessel.

The charge pressure must not be less than the static head of the system, that is, the height of the highest point of the system above the expansion vessel.

3.18.3 Pressure gauge

A pressure gauge with a set pointer and covering at least 0 to 4 bar (0 to 60 lb/in²) shall be fitted permanently to the system in a position where it can be seen when filling the system.

3.18.4 Water make up

Provision should be made for replacing water loss from the system using a make up bottle mounted in a position higher than the top point of the system, connected through a non-return valve to the return side of either the heating circuit or the hot water cylinder. Alternatively, provision for make up water should be made using a proprietary filling loop.

3.18.5 Filling a sealed water system

Provision for filling the system at low level must be made. This can be achieved by the use of a proprietary filling loop.

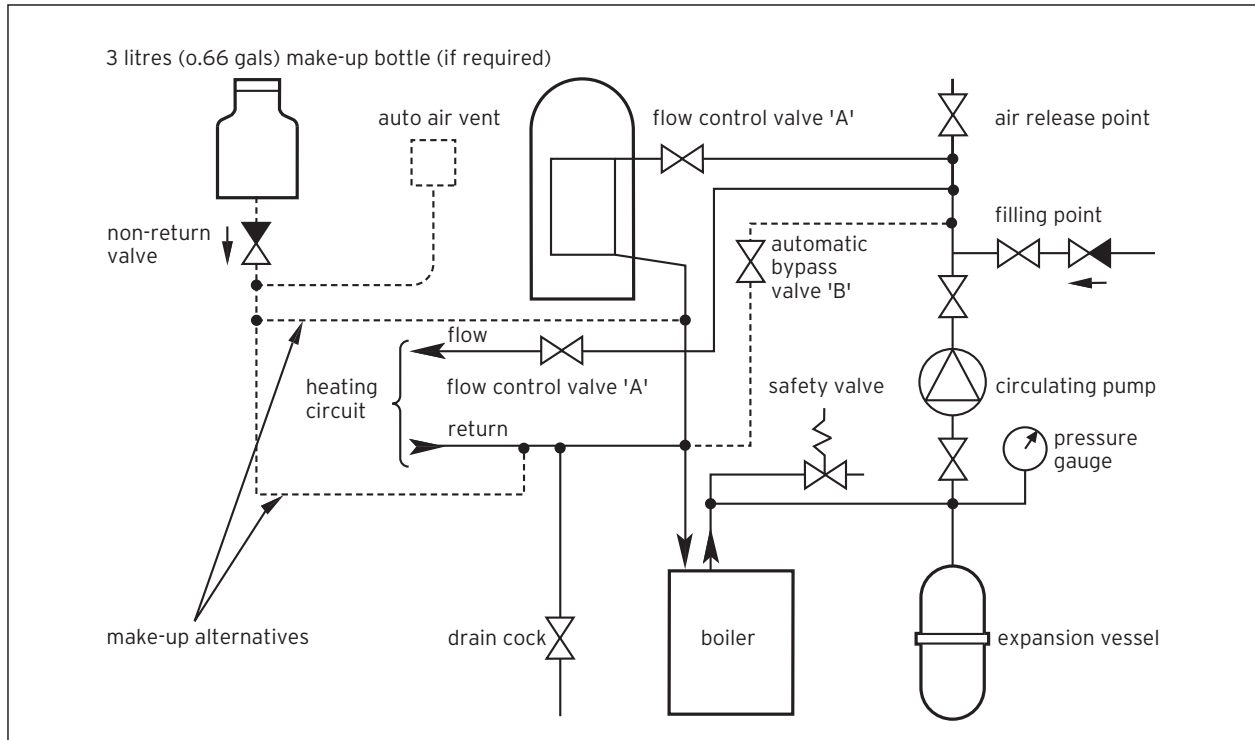

Fig. 3.10 Typical installation

4 Boiler installation sequence

4 Boiler installation sequence

4.1 Boiler location

Note!
This boiler is not suitable for outdoor installation. This boiler may be installed in any room, although particular attention is drawn to the installation of a boiler in a room containing a bath or shower where reference must be made to the relevant requirements. This boiler is suitable for installation in bathroom zone 2.

4.1.1 Sheet metal parts

Caution!
When installing the appliance, care should be taken to avoid any possibility of personal injury when handling sheet metal parts.

In GB this is the current I.E.E. WIRING REGULATIONS and BUILDING REGULATIONS. In IE reference should be made to the current edition of I.S.813 "Domestic Gas Installations" and the current ETCI rules. The boiler must be mounted on a flat wall, which is sufficiently robust to take its total weight, see boiler specifications 2.1.

4.1.2 Clearances

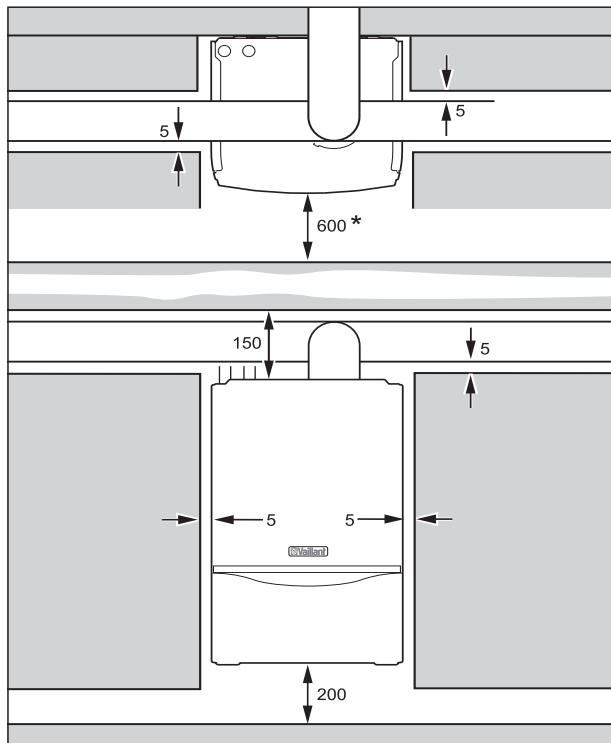

Fig. 4.1 Distance during installation

* A removable compartment door can be placed at least 5 mm in front of the appliance

The boiler should be positioned so that at least the minimum operational and servicing clearances are provided, see fig 4.1. Additional clearances may be beneficial around the boiler for installation and servicing. For flue installations where external access is not practicable, consideration should be given for the space required to insert the flue internally, which may necessitate clearance larger than those specified in fig 4.1.

4.1.3 Timber frame buildings

If the boiler is to be installed in a timber frame building it should be fitted in accordance with the Institute of Gas Engineers document IG/UP/7 Edition 2 "Gas installations in timber framed and light steel framed buildings". If in doubt seek advice from the local gas undertaking or Vaillant.

4.1.4 Contents included with delivery

The Vaillant ecoTEC plus is delivered pre-mounted in a package unit. Check that all the parts have been delivered intact (see fig. 4.2 and table 4.1. Do not remove the boiler from the polystyrene base at this stage. Place aside the flue adaptor and connections pack until required.

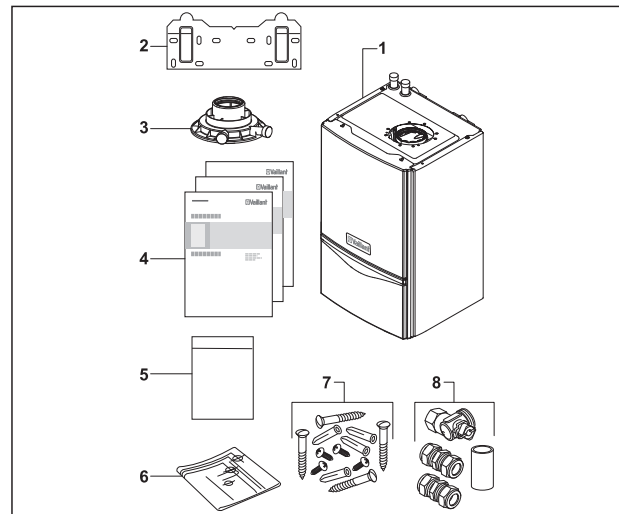

Fig. 4.2 Contents included with delivery

Item	Quantity	Description
1	1	Boiler
2	1	Hanging bracket
3	1	Flue connection adaptor
4	1	Instruction booklets
5	2	Guarantee card and envelope
6	1	Template
7	1	Screws/wallplugs
8	1	Gas service valve, compression couplers and condense drain pipe coupler

Table 4.1 Contents included with delivery

Note!
Care should be taken not to scratch the white surface of the boiler casing.

4.2 Flue exit

Refer to flue system installation instructions for full details.

Danger!
Vaillant appliances are certified only for use with genuine Vaillant flue pipes. Only use genuine Vaillant flue pipes. Malfunctions can occur if you use other accessories. These may result in damage and injury. You will find a list of genuine flue pipes in the Vaillant installation manual for flue pipes. The CE mark is valid only if the appliance is operated with Vaillant flue pipes.

4.2.1 Other flue options

Flue instructions for other flue systems such as vertical RSF flues, flues run to the side of the boiler and the use of additional bends etc. are detailed in the flue installation instructions.

4.3 Fitting the boiler hanging bracket

Reposition the wall template over the flue hole ensuring the template is vertical and mark the position of the fixing holes for the hanging bracket, see fig 4.3. Mark and drill the fixing holes and secure the hanging bracket. Fix the hanging bracket to the wall using the screws supplied. Ensure the uppermost set of screw positions are used (it may be necessary to use additional or alternative fixings to ensure adequate support).

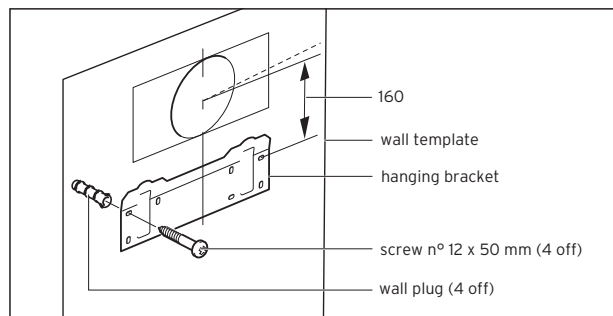

Fig. 4.3 Boiler hanging bracket

Note!
If the boiler is to be fitted in a timber framed building ensure that the bracket is secured to a substantial part of the timber frame capable of taking the weight of the boiler.

4.3.1 Boiler fixing

Lift the boiler into position in the following manner: Lean the top of the boiler slightly to the wall and position just above the hanging bracket. Allow the boiler to

slowly move downwards until engaged in the hanging bracket.

4.3.2 Removing the front casing

Remove the front casing securing screws then lift the case upwards off the two top retaining dowels, see fig 4.4.

Note!
Take care not to damage the front casing.

4.3.3 Gas connection

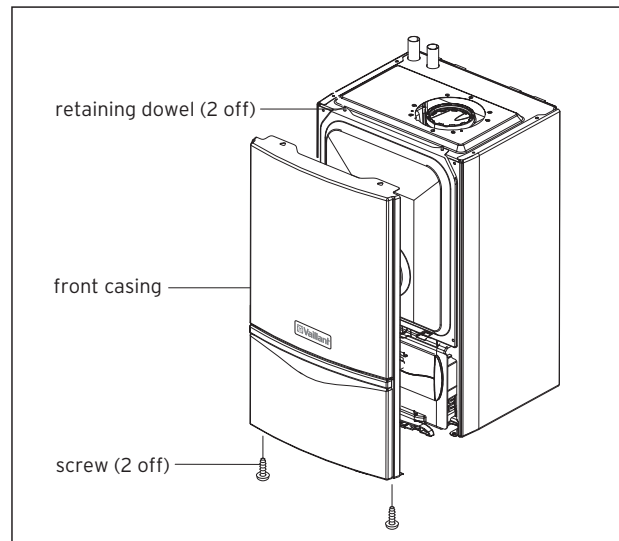

Fig. 4.4 Removing front casing

Danger!
The gas connection may only be made by a competent person approved at the time by the Health and Safety Executive. The legal directives and the local regulations for gas supply companies must be observed.

Caution!
Ensure a stress-relief assembly of the gas pipes to avoid leakages!

Caution!
The gas regulating block may be tested for leakage only with a maximum pressure of 150 mbar! Higher testing pressures can damage the gas fitting.

Caution!
When making final connection to the boiler, if using soldered fittings, extra care should be taken to avoid damage to isolation valves through heat transfer. Before connection check the supply of local gas.

4 Boiler installation sequence

- Note!**
Ensure the gas supply pipe work is adequately sized so that a 20 mbar gas pressure is available at the boiler inlet at full flow rate.
- Tighten all connections.
 - Check the gas connection with leak indicator spray for leakage.

The gas supply can be connected from below, or through the wall at the rear of the boiler. See fig 4.5. and refer to section 3.4. The whole of the gas installation, including the meter, should be inspected, tested for soundness and purged in accordance with the current issue of BS6891 and in IE the current edition of I.S.813 "Domestic Gas Installations".

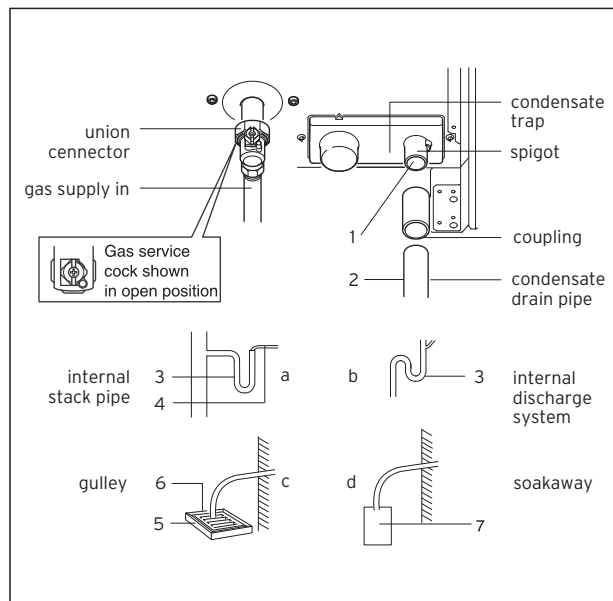

Fig. 4.5 Gas and condensate connections

4.3.4 Water connections

- Caution!**
When making final connection to the boiler use the compression fittings supplied to avoid damage through heat transfer.

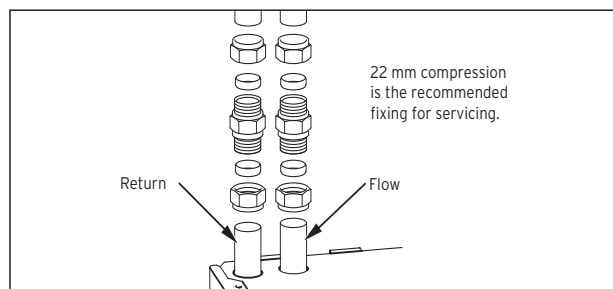

Fig. 4.6 Water connections

Provision is made for the water connections to be made from above the boiler, see fig 4.6 (using the two 22 mm compression couplers supplied). The position is shown on the wall template. Flush out the domestic hot water and the heating systems before connecting to the boiler.

4.3.5 Condensate trap and siphonic drain connection

The condensate drain pipework must have a continuous-fall (45 mm per metre) and should whenever possible terminate at a suitable drain point within the heated envelope of the building that will remain frost free under long periods of low external temperatures.

- During installation remove all burrs from inside of cut pipe work and avoid excessive adhesive which may trap small pockets of water close to the pipe wall which can freeze and build into a larger ice plug.
- As with other pipe work insulate the condensate discharge pipe to minimise any risk of freezing and beware when crossing cavities that the fall is maintained and the pipe sleeved.

Refer to fig 4.5. The condensate drain connection is at the underside rear of the boiler. The condensate drain is suitable for use with standard overflow pipe and couplings do not use adhesive when connecting to the spigot (1) The condensate drain pipe (2) should be plastic. The condensate is discharged periodically in 'slugs' by siphonic action. It is not necessary to provide air breaks or extra traps in the discharge pipe as there is already a 75 mm high trap inside the boiler. Fitting an extra trap may cause the boiler siphon to work incorrectly. Refer to BS5546 or BS6798 for advice on disposal of boiler condensate.

- Preferably the drain pipe should run and terminate internally to the house soil and vent stack at least 450mm above the invert of the stack.
- Connecting into the internal discharge branch (e.g. sink waste or washing machine) with an external termination, the condensate drain pipe should have a minimum diameter of 22 mm with no length restriction and preferably made down stream of the sink waste trap, if the connection is only possible up stream, then an air break is needed between the two traps. This is normally provided by the sink waste.
- Termination in a gully (5) below grid level (6) and above the water level. The external pipe length should be kept as short as possible to minimise the risk of freezing and should not be more than 3 metres.
- At a condensate absorption point (soak away) (7). The external pipe length should not be more than 3 metres.

Refer to the latest issue of BS 6798 Specification for installation of gas fired boilers of rate input not exceeding 70kW net for further information. Before operating the boiler the condensate trap must be filled with water.

4.3.6 Installing the flue system

- Install the flue system (refer to the separate air/flue duct installation instructions).

4.4 Electrical connections



Danger!

This appliance must be earthed. Electrocutation caused by touching live parts can be fatal. Before working on the appliance, turn off the power supply and secure against restart.

- The boiler must be earthed.
- All system components shall be of an approved type and all wiring to current I.E.E. wiring regulations.
- External wiring must be correctly earthed, polarised and in accordance with the relevant standards.
 - In GB this is BS 7671.
 - In IE this is the current edition of I.S.813 "Domestic Gas Installations".
- The boiler must be connected to a permanent 230V ac, 50Hz supply.
- Connection of the whole electrical system of the boiler, including any heating controls, to the electrical supply must be through one common isolator and must be fused 3 Amp maximum.
- Isolation should be by a double pole switched fused spur box, with a minimum gap of 3 mm for both poles. The fused spur box should be readily accessible and preferably adjacent to the appliance. It should be identified as to its use.
- Alternatively connection can be made through an unswitched shuttered socket and 3A fused 3-pin plug both to the current issue of BS 1363 may be used, provided they are not used in a room containing a bath or shower.
- A 3 core flexible cord according to BS6500 tables 6, 8 or 16 (3 x 0.75 to 3 x 1.5mm²) should be used.



Caution!

This appliance must be wired in accordance with these instructions. Any fault arising from incorrect wiring cannot be put right under the terms of the Vaillant guarantee.



Danger!

Mains connection terminals L and N remain live "unless isolated at the fused spur or electrical outlet supplying the boiler".



Caution!

Do not connect any mains 230V power to the connections 7-8-9 or BUS (+,-).



Note!

Ensure that all cables pass through grommets in the outer casing and are securely fixed by the cable clamps in the rear of the electronics box. Ensure that the power supply is connected such that the current carrying conductors become taut before the earth conductor should the supply cable slip from the cable clamp.

4.4.1 Connection to the main supply

- Lower the electronics box, see fig. 4.7.

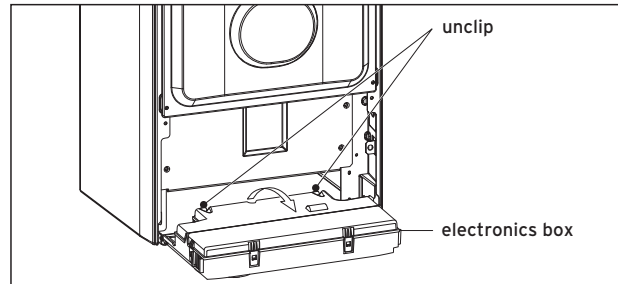

Fig. 4.7 Mains Supply Connection

Opening the electronics box

- Unclip the bottom of the electronics box cover and hinge back to reveal the connection plugs.
- Feed the power supply flex into the appliance and the electronics box through the cable clamps provided.

4 Boiler installation sequence

4.4.2 Wiring system

- Connect the mains supply to the terminal block, see fig 4.8.1 the pump can be connected directly to the terminal block or alternatively as shown in diagram 4.8.2 .

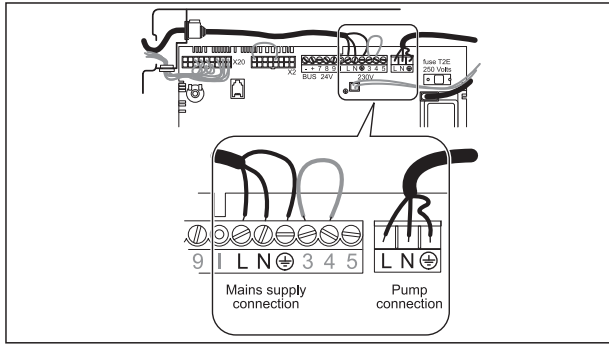

Fig 4.8.1 Mains Supply Connection

Note!

- Ensure that the wires are securely fixed in the terminal block.
 - Refit the electronics box cover by pushing into place until it clips back into position.
 - Raise the electronics box.
- Check the electrical installation by carrying out short circuit, earth continuity and resistance to earth tests and a check for correct polarity.

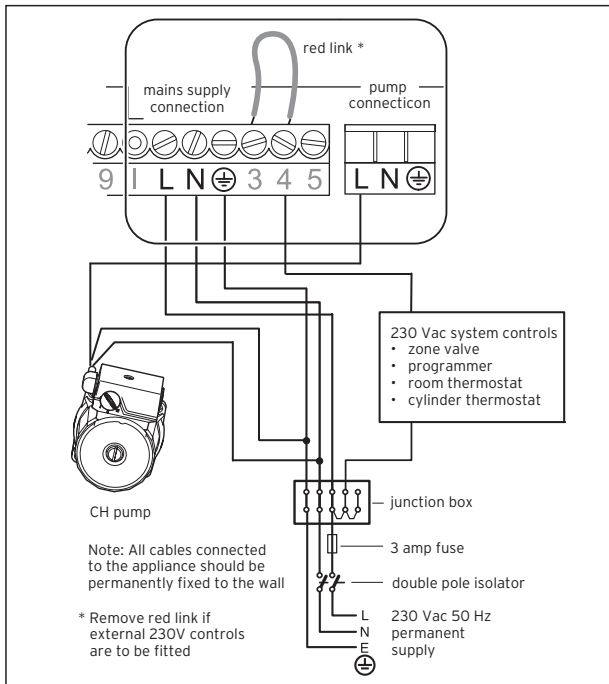

Fig. 4.8.2 Mains supply and alternative pump switch live connection

Green/yellow (earth) wire - boiler terminal Earth sign
 Blue (neutral) wire - boiler terminal N
 Brown (live) wire - boiler terminal L



Caution!

Do not connect any mains 230V power to the connections 7-8-9 or BUS (+,-).

4.4.3 Electrical board layout

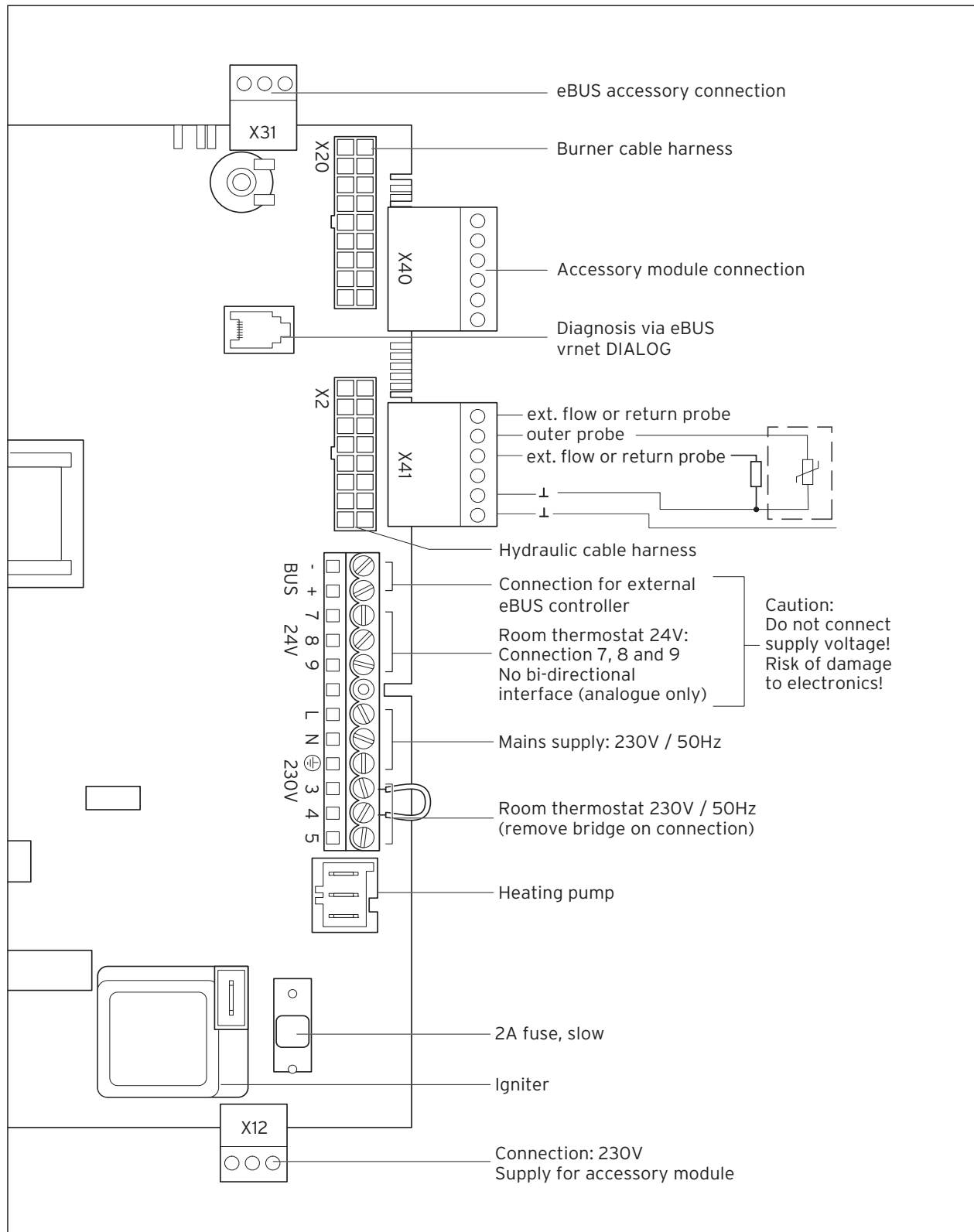

Fig. 4.9 Connection wiring

4 Boiler installation sequence

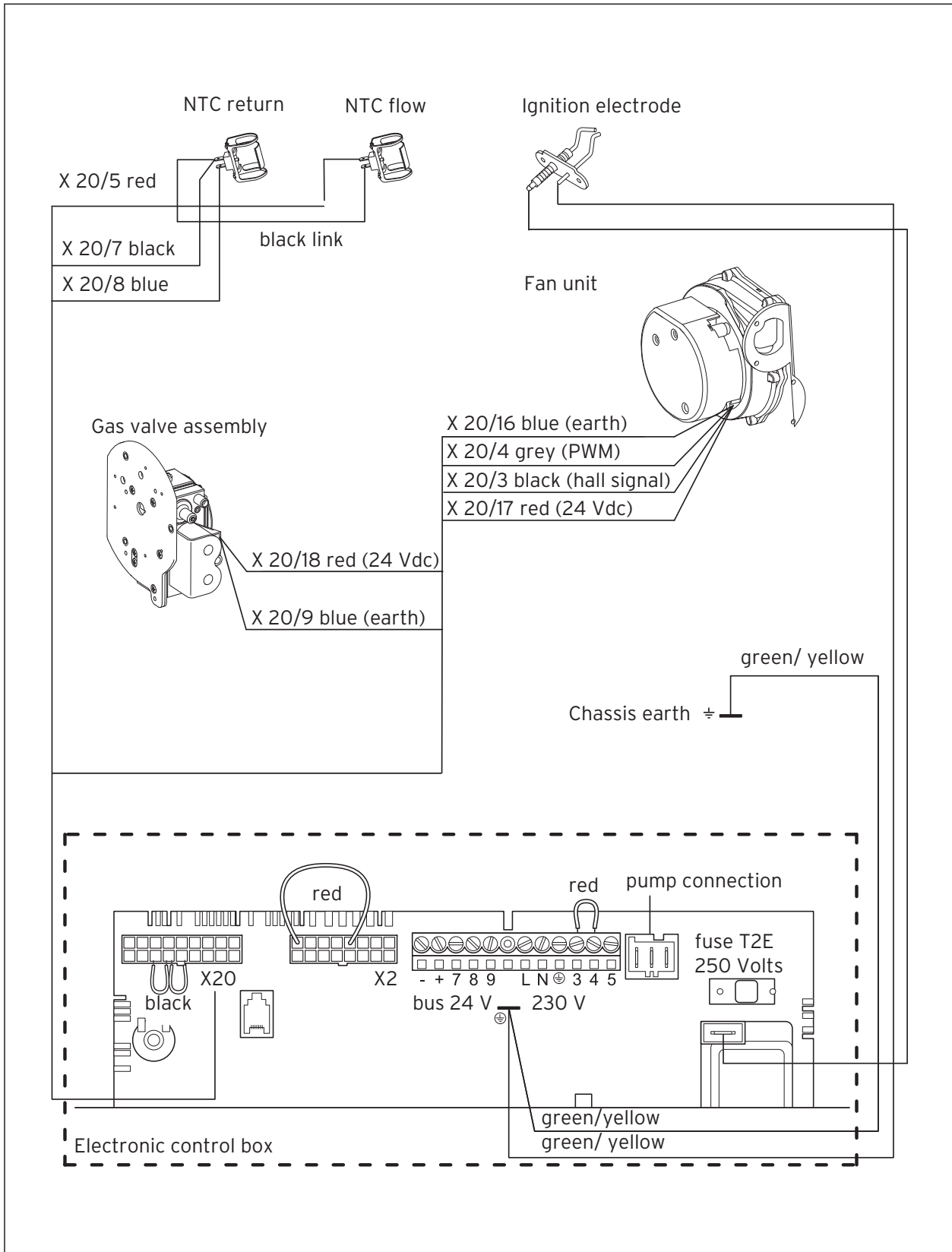

Fig. 4.10 Mains Supply Connection

4.4.4 Controls

Controls	Article no.	Installation
VRT 392 Programmable Room Control	0020028509	Wall mounted
VRT 392f RF Programmable Room Control	0020028514	Wall mounted
VRC 470 Weather Compensator	0020108130	Wall mounted or plug in
VRC 470f Weather Compensator (From Q3 2011)	0020108137	Wall mounted
Accessories	Article no.	Installation
VR 65 control centre	307215	Allows ebus connection of 1 x hot water and 1 x heating zone
VR 61/2 Mixer Module	002019330	Allows two zone heating systems to wire to ebus system Note: Wiring harness plug x2 may be required. Contact our technical dept for details.
VR 81/2 Remote Control Unit	0020129323	Allows remote control of 1 zone or Temperature control of a second zone
VR 68/2 Solar Module	0020129873	Allows Weather compensator to add solar control functionality

Table 4.2 Vaillant controls
(used in conjunction with the VR 65 accessory)

4.4.5 External electrical controls

The boiler terminals 3, 4 and 5 are for connecting external electrical controls. Terminals 3 and 4 are linked together when the boiler is supplied. If external controls are used, this link must be removed, and the controls connected to terminal 4. Terminal 5 is an additional neutral connection for external neutrals such as from the anticipator of a room thermostat.

4 Boiler installation sequence

4.4.6 Connection details for external switches and boiler terminal strip.

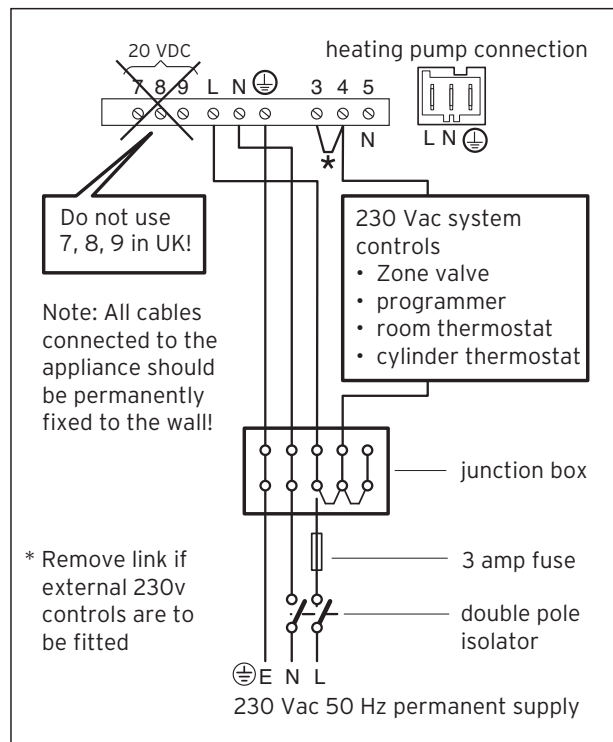

Fig.4.11 Mains Supply and External Controls

4.4.7 Vaillant optional plug in timer accessories

Refer to the instructions supplied with the optional accessories for connection details. Upon completion of all electrical connections refit the terminal box cover by pushing into place. The cover is secured by two locking clips.

4.4.8 Connection details using the VR 65 and VR 61 control centre

The Control Centre VR 65 and VR 61 are eBUS system components. In a storage unit cylinder installation, they are responsible for the communication between the ecoTEC plus boiler and external 2- or 3-way-valves. Connect the VR 65 or VR61 Control Centre as described in its enclosed manual.



Note!

When using a VR61 an optional wiring harness plug is available from Vaillant technical (Telephone 01634 292 392) to allow easy connection of the domestic hot water demand direct to the boiler. If using in conjunction with Solar and a VR68 this plug is not required.

5 Commissioning (Part I)

Please ensure the “Benchmark” commissioning check list is completed and left with the user.

5.1 Preliminaries - all systems

A competent person approved at the time by the Health and Safety Executive should carry out commissioning, in accordance with the current issue of BS 6798.

- Remove the two screws on the inner case then lift the case upwards off the two top retaining dowels.
- Drop down the electronics box into the service position.
- Remove the four screws from the chassis panel.
- Remove the chassis panel by pulling it out at the top from its retaining slots, see fig 5.1.

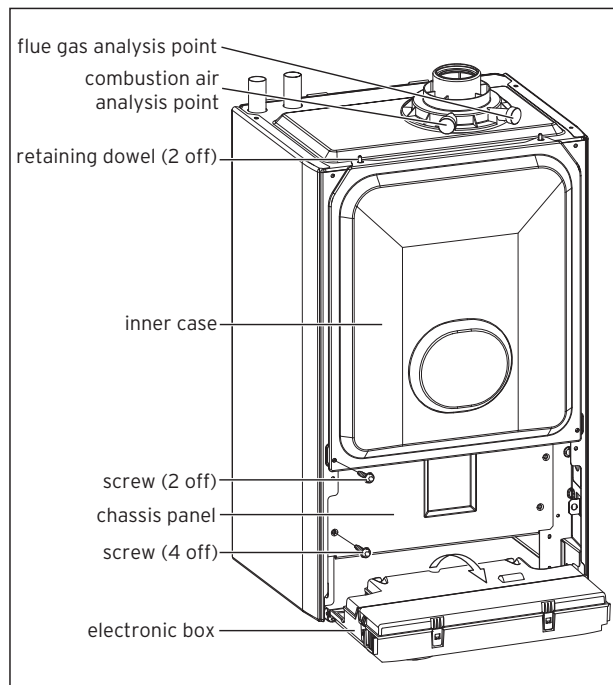

Fig. 5.1 Inner case and chassis removal



Note!

When replacing chassis panel ensure the bottom fits behind lip.

- Make sure that the system has been thoroughly flushed out with cold water, prior to filling the system refer to section 3.16 inhibitor cleaning.
- Refill the system with water, making sure that all the air is properly vented from the system and pump.

5.1.1 Gas supply

- Isolate the boiler from the mains electrical supply. The complete gas installation including the gas meter must be isolated, tested for soundness and purged in accordance with BS 6891, in IE the current edition of IS 813.

The gas supply to the boiler can be purged by slackening the union connection on the gas service valve beneath the boiler, see fig 5.2. Ensure that there is adequate ventilation, extinguish all naked flames and do not smoke whilst purging.

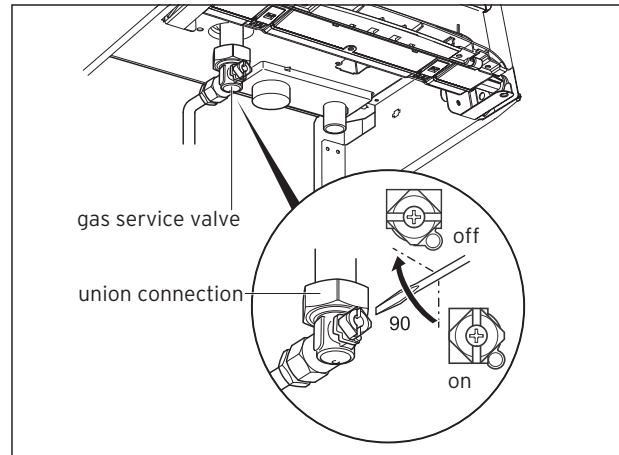

Fig. 5.2 Gas service valve

After purging, the gas service union connection must be re tightened and tested for soundness. (The boiler itself does not require purging as this will be done by the automatic burner sequence control). The gas valve is factory set for natural gas (G20) and should need no adjustment. The supply pressure should be checked when the boiler is firing at full rate. Check the inlet pressure at the pressure test point on the gas valve shown in fig 5.3 the values should be between those shown below.

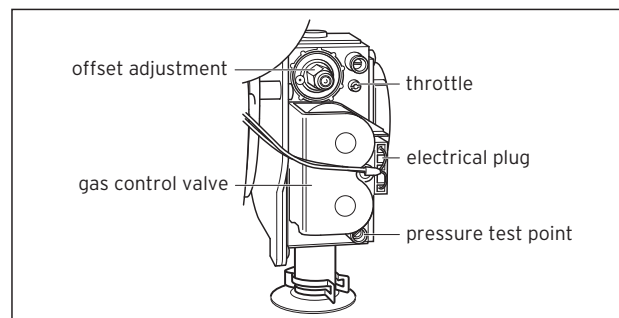

Fig. 5.3 Gas control valve



LPG:

Do not proceed with the adjustment or attempt to put the unit into service if the inlet working pressure is lower than 34 mbar.



Caution!

Before operating the boiler check the type plate and ensure that the correct gas type appliance has been installed.

5 Commissioning (Part I)

5.1.2 Gas pressure statement - Natural gas



Natural gas:

Do not proceed with the adjustment or attempt to put the unit into service if the inlet working pressure lies outside the range shown in table 5.1

The nominal operating pressure at the gas meter outlet should be between 19 and 23 mbar. The gas valve within the appliance is factory set for Natural Gas G20 and should need no adjustment. The appliance is designed to operate with an inlet pressure to the appliance of 20 mbar when the appliance is operating at the maximum heat input. The inlet working pressure to the appliance is measured at the appliance multi-functional gas valve on the valves inlet pressure test point, see fig. 5.3. Due to internal appliance pressure losses the reading at the inlet of the appliance gas valve may be lower than the design pressure of 20 mbar.

The acceptable pressure measured at the appliance gas valve inlet is:

Natural Gas (G20)	Meter outlet pressure	Minimum pressure at gas valve inlet
ecoTEC plus 415/418/428	Maximum	23 mbar
	Design (nominal)	21 mbar
	Minimum	19 mbar
ecoTEC plus 438	Maximum	23 mbar
	Design (nominal)	21 mbar
	Minimum	19 mbar

Table 5.1 Acceptable pressure measured at the appliance gas valve inlet



Note!

In all instances the gas rate to the appliance shall be measured.



Caution!

Should the pressure recorded at the gas meter not be between 19 mbar and 23 mbar then the Emergency Service Provider should be contacted.



Caution!

Should the pressure at the gas meter be correct but lower pressure at the gas valve than indicated in the above table, it may indicate blockage in the internal pipework or that the pipework is undersized. Rectification work must be undertaken before the appliance is commissioned.

5.1.3 Initial Lighting

The combustion for this appliance has been checked, adjusted and preset at the factory for operation on natural gas (G20) as defined on the appliance data label.

Do not adjust the Gas/Air ratio valve. No measurement of the combustion is necessary, having checked:

- the appliance has been installed in accordance with the instructions.
- the integrity of the flue system and flue seals.
- the integrity of the appliance combustion circuit and relevant seals.
- the gas service isolation valve, diagram 10.1, is open.

The lighting procedure of the boiler is fully automated.

- To prepare the boiler for initial lighting first ensure that all external controls are calling for heat.
 - For access open the front flap by pulling at the centre of the case strip.
 - Turn on the power to the appliance whilst holding the + button - keep held until the PO appears.
 - release and press the + button until P1 is displayed on the screen.
 - With ALL other gas appliances operational.
 - Press the I button to commence operation at FULL gas rate to carry out the gas pressure test.
 - Ensure that the heat generated can be dissipated into the heating system.
 - Measure the gas pressure at the test point.
 - When completed turn off all gas appliances and remove the pressure gauge, ensure all gas test points are safely tightened.
 - Repeat procedure - starting the boiler in P1 mode. This time checking the appliance gas rate at the gas meter.
 - Ensure the test results are in line with tables 5.1 and 5.2
 - Once completed press I and +
- The appliance operating status appears on the screen see Fig 5.4 (2).

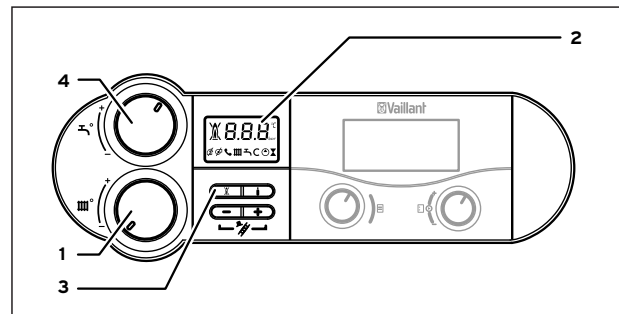

Fig. 5.4 Switching on the appliance



Note!

Allow the boiler to run on minimum until commissioning is complete.

In the unlikely event that a problem occurs with the operation of the ecoTEC boiler, the following points should be checked:

Boiler fails to operate:

- Is the gas supply turned on?
- Is there enough water in the heating system?
- Is the electrical supply switched on?
- Is the control knob (1, fig 5.4) in the operating position?
- Is there an ignition problem?

 **Caution!**
Inappropriate modifications can cause damage. If your boiler still does not operate then please consult the trouble shooting section of this literature.



5.1.4 Ignition problems

If the burner fails to ignite after five attempts, the device does not start up and switches to "Fault". This is indicated by the fault code "F.28" or "F.29" in the display. The display also shows the flame symbol with a cross through it (2), see fig 5.4. Automatic ignition can only take place after you manually reset the fault.

- To reset the fault, press the reset button (3), see fig 5.4. and hold it down for one second.

 **Caution!**
If the boiler still shuts off after three attempts of resetting, please consult the trouble shooting section of this literature.

5.1.5 Flue problems

This appliance is fitted with a fan. If the fan does not work properly, the appliance will switch itself off. The display shows the symbols  and  and the fault message "F.32".

 **Note!**
If contacting Vaillant Service Solutions please remember to quote the fault code, as this will help to pinpoint the fault.

5.1.6 Testing - gas

The boiler is supplied ready adjusted and no further gas adjustments are necessary.

 **Note!**
The burner pressure cannot be measured at the gas valve due to the fan/burner design. Replace the inner and front casing panels. Record appliance working gas inlet pressure (mbar) in Benchmark Installation, Commissioning and Service log.

 **Caution!**
If the measured gas flow volume lies outside the tolerance limits specified in Table 5.2, *do not operate the appliance and inform the Vaillant Customer Service.

Model	Nominal net heat input as per BS EN 483 (kW)	Gas Rate					
		Natural gas (m ³ /h)			Propane (kg/h)		
		nom.	+5%	-5%	nom.	+5%	-5%
415	15.26	1.62	1.70	1.54	1.19	1.25	1.13
418	18.90	2.00	2.10	1.90	1.47	1.54	1.40
428	28.60	3.03	3.18	2.88	2.22	2.33	2.11
438	38.35	4.06	4.26	3.86	2.98	3.13	2.83

Table 5.2 Gas Rate

6 Natural gas to LPG conversion

6 Natural gas to LPG conversion

The ecoTEC plus is able to be field adjusted for use on LPG - propane G31 gas. To enable conversion the use of a **flue gas analyser** is necessary.

Caution!
After converting from natural gas to LPG, commission and check boiler function as described in commissioning section of the servicing and installation instructions.

Caution!
This conversion must only be carried out by a competent person approved at the time by the Health and Safety executive and in accordance with the gas safety (installation and use) regulations 1998.

Before starting any work:

- Isolate the electrical supply to the boiler.
- Turn off the gas supply at the gas service cock fitted to the appliance.
- Turn the gas valve "A" throttle screw (Ref fig.6.1) fully clockwise.
- Turn the "A" throttle screw back anti-clockwise the required number of turns as stated in Table 9.1 for the boiler installed.
- Ensure the gas analyser is set to the correct fuel setting propane.

To obtain conversion follow the procedure as listed below.

- Ensure that the gas supply pressure is in the range 34 - 37 mbar. The gas inlet working pressure can be checked at the pressure test point on the gas valve (fig 5.3.).
- Turn gas supply on.
- Ensure there is an external heat demand.
- Enter the test programs by holding the "+" key, see fig 6.2. and turning power on.
- Press "+" until "P.1" is displayed for max rate.
- Press "i" to operate appliance in this mode.
- Allow appliance to stabilise.
- Measure the CO₂ at the flue gas analysis point, see fig 9.1.
- Check CO₂ value (for case off) as stated in table 6.1 for the boiler installed.

- If required, using a screwdriver, adjust the "A" throttle to obtain correct value. (rotating anti-clockwise to increase). Appliance will remain in this mode for 15 minutes or exit by pressing "i" and "+" simultaneously.
- Repeat the process above and select "P.2" for min rate.
- Press "i" to operate appliance in this mode.
- Allow appliance to stabilise.
- Check CO₂ value (for case off) as stated in table 6.1 for the boiler installed.
- If required, using a 2mm allen key, adjust the "B" offset to obtain correct value. (rotating clockwise to increase)
- After checking the combustion, exit by pressing "i" and "+" simultaneously
- Refit the chassis panel and the inner case. (Note the CO₂ will increase slightly).
- Fit the LPG conversion label to the type plate.
- Lift the control box into place and fit the front casing.
- Commission the boiler as described in the Installation and Servicing Instructions supplied with the boiler.

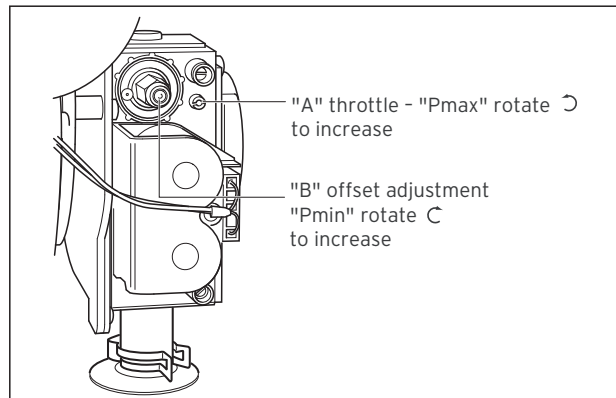

Fig. 6.1 Gas control valve

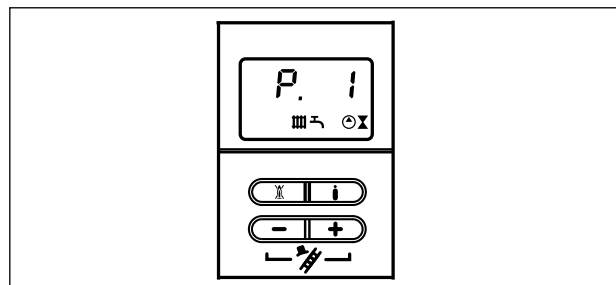

Fig. 6.2 ecoTEC plus controls

Model	LPG			
	G31 % CO ₂ after 5mins at full load		Throttle	Maximum
	Case off	Case on	Adjustment	CO/CO ₂ ratio
ecoTEC plus 415	10.1 + 0.5 - 0.5	10.3 + 0.5 - 0.5	5 turns	<0.0026
ecoTEC plus 418	10.1 + 0.0 - 1.0	10.3 + 0.0 - 1.0	5 turns	<0.0026
ecoTEC plus 428	10.5 + 0.3 - 0.8	10.7 + 0.3 - 0.8	5 turns	<0.0026
ecoTEC plus 438	9.8 + 0.2 - 0.8	10.0 + 0.2 - 0.8	8 turns	<0.0026

Table 6.1 LPG settings

7 Functional checks commissioning (part II)

7.1 Functional checks

After installing and checking the gas supply pressure, perform a function check before commissioning the appliance and handing over to the user.

- Commission the appliance according to the relevant operating manual.
- Check the gas supply pipe, flue system, heating system and the hot water pipes for leaks.
- Check that the flue system has been installed properly according to the flue system installation manual.

Checking for tightness of the flue gas installation and flue gas recirculation

- Check the integrity of the flue gas installation according to TB 200.

Should the flue gas installation be longer than 2 m we strongly recommend to check the system for flue gas recirculation as described below.

- For checking the system for flue gas recirculation use the combustion air analysis point shown at 8.1 (page 34).
- Use the flue gas analyser.
- If you detect any CO or CO₂ in the fresh air, search for the flue gas leakage or recirculation.
- Correct the defects.
- Check again as described before, if there is any CO or CO₂ in the fresh air.
- If you cannot correct the defects you must not start up the boiler.
- Check for ignition and an even flame on the burner.
- Perform a function check on the heating system (see Section 7.1).
- Perform a function check on the domestic hot water system (if applicable optional accessories are fitted) (see Section 7.1.1).

7.2 Heating

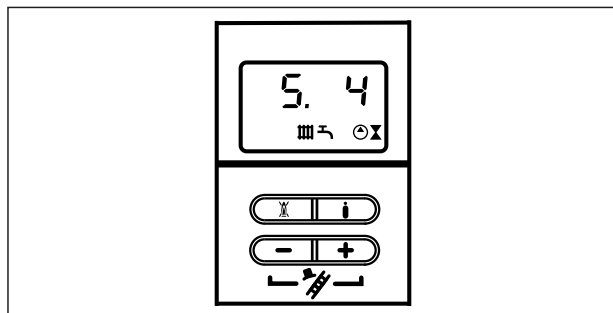

Fig. 7.1 Display indicator during heating mode

- Switch on the appliance.
- Make sure that there is a heating demand.
- Press “i” to activate the status indicator.

As soon as a heat demand is received, the appliance runs through the status indicators “S. 1” to “S. 3”, until the appliance is running correctly in normal mode and the display shows “S. 4”.

7.3 Domestic hot water (If optional VR65, uniSTOR cylinder and Vaillant control are installed)

- Switch on the appliance.
- Fully open the hot water tap.
- Press “i” to activate the status indicator. If the water heating is working correctly, the display shows the following: “S.24”.

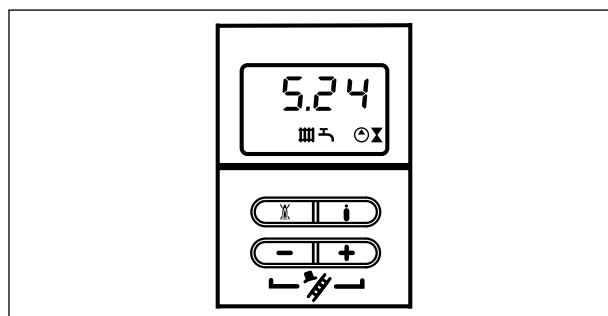

Fig. 7.2 Display indicator during water heating

7.4 Pump exercise programme

After a power cut or every 23 hour in frost protection mode the pump will run for one minute to prevent it from sticking. This will also occur during normal operation if there is no demand for more than 24 hours.

7.5 Final flush of the heating system (hot)

- Operate the appliance until the heating system is up to temperature.
- Check the heating system for leaks.
- Connect a hose to the drain valve located at the lowest position of the heating system.
- Shut off the appliance, open the drain valve and all bleed valves on the radiators and allow the water to flow out of the heating system and the boiler quickly and fully.
- Close the drain valve.
- Fill the heating system again with water.
- If fitted to a sealed system. Release water from the system until the system design pressure is attained. (The actual reading on the digital pressure gauge should ideally be 0.5 bar plus an additional pressure corresponding to the highest point of the system above the base of the boiler 10 m head equals an additional 1 bar reading on the pressure gauge. The minimum pressure should not be less than 1 bar in any installation.) If the system is to be treated with an inhibitor it should be applied at this stage in accordance with the manufacturer’s instructions (see section 3.16)
- Refit the boiler casing (see section 5.10)

7 Functional checks commissioning (Part II)

8 Inspection and maintenance

7.6 Handing over to the user

**Note!**

When you have finished the installation, attach the sticker supplied (835593) to the front case of the appliance in the user's language.

**Note!**

If fitted to a sealed system.

- Set the maximum radiator temperature control to the desired setting.
- Set the maximum hot water temperature control to the desired setting (If optional Vaillant accessories are fitted).
- Instruct the user in the safe and efficient operation of the boiler.
- Go through the operating manual with the user and answer any questions.
- Show the user how to operate any external controls.
- Explain to the user the importance of having the boiler regularly serviced by a competent servicing company. To ensure regular servicing, it is strongly recommended that arrangements are made for a maintenance agreement. Please contact Vaillant Service Solutions (0870 6060 777) for further details.
- If applicable record central heating operating pressure in the Benchmark gas boiler commissioning checklist along with the heat input (kW) and temperature difference between flow and return.
- Leave the user instructions and the installation instructions with the user.
- Inform the user that the instruction manuals should be kept near the appliance.

8 Inspection and maintenance

8.1 Inspection and maintenance intervals

**Danger!**

Risk of injury and risk of damage to property due to neglected inspection and maintenance! Neglected inspection and maintenance works or not observing the stated inspection and maintenance intervals can interfere with the operational safety of the boiler and can result in damage to property and to persons.

- Point out to the operator that he must observe the demanded inspection and maintenance intervals as a minimum.
- Carry out proper regular inspections once a year.
- Carry out regular maintenance as dictated by findings during the inspection process. The frequency of maintenance must not be longer than every 5 years.

**Danger!**

Danger to life and limb due to improper inspection/maintenance!

Inspections/Maintenance work carried out improperly can result in leakages and explosion.

- The boiler may only be inspected/maintained by a competent person.

All service work must be carried out by a competent person in accordance with the Gas safety, installation and use regulations. In the UK this is considered to be a person approved at the time by the Health and Safety Executive.

In addition BS 6798: 2009 "Specification for installation and maintenance of gas-fired boilers of rated input not exceeding 70 kW net" advises that:

- The person carrying out a combustion measurement must be assessed as competent in the use of a flue gas analyser and the interpretation of the results.
- The flue gas analyser used must be one meeting the requirements of BS7927 or BS-EN50379-3 and be calibrated in accordance with the analyser manufacturers' requirements.
- Competence can be demonstrated by satisfactory completion of the relevant ACS standard assessment, which covers the use of electronic portable flue gas analysers' in accordance with BS 7967, parts 1 to 4.
- The flue gas analyser is set to the correct fuel setting.

**Note!**

Safe combustion can only be verified by measuring CO/CO₂ ratio. This must not exceed the value shown in table 9.1.

We recommend the conclusion of an inspection and maintenance contract with an approved company or installer. The inspection serves to determine the actual condition of the respective boiler and compare it with the specified condition. This is done by measuring, checking and observing.

Maintenance is required in order to eliminate any deviations of the actual condition from the specified condition. This normally is done by cleaning, adjustment and, if necessary, replacing individual components that are subject to wear. You must carry out an annual inspection of the Vaillant ecoTEC.

It is possible to perform a quick, accurate inspection without removing components by carrying out the simple visual checks indicated in Table 8.2 and performing a flue gas measurement.

The maintenance intervals (at least once every 5 years) and their scope are determined by the heating engineer based on the condition of the boiler found during the inspection.

All inspection and maintenance work should be performed in the order specified in Table 8.2.



Danger!

Possible poisoning and burning by escaping hot flue gases!

It is possible that hot flue gases escape and could result in poisoning or burning, if the boiler is operated

- without a completely installed air/flue gas duct,
- with an open air/flue gas duct,
- with internal leakages and an opened front casing.
- Operate the boiler with care
 - for commissioning,
 - for testing purposes.
- Operate the boiler in continuous mode only with closed front casing and completely mounted and closed air/flue gas duct.

8.1.1 General inspection and maintenance instructions

To ensure the faultless operation, long term availability of all functions and long working life of your Vaillant boiler and to prevent modifications to the approved series status only genuine Vaillant spare parts must be used when carrying out inspection, maintenance and repair work. For an overview of the available original Vaillant spare parts, contact the Vaillant sales office on 01634 292310.

During any inspection and maintenance or after change of parts of the combustion circuit, the following must be checked:

- The appliance has been installed in accordance with the relevant installation instructions.

- The integrity of the flue gas installation and flue seals is in accordance with the relevant flue installation instructions enclosed.
- Visual, the integrity of the boiler combustion circuit and relevant seals.
- The gas inlet working pressure at maximum rate as described in section 5.1.2.
- The gas flow rates as described in section 5.1.6.
- Correctness of electrical, water and gas connections.
- Correctness of the water pressure.
- The condition of the whole system, in particular the condition of radiator valves, evidence of leakage from the heating system and dripping taps.



Note!

If it is necessary to keep the main switch on for certain inspection and maintenance, this is indicated in the description of the maintenance task.



Note!

The boiler is fitted with a flue gas analysis point. A suitable flue gas analyser can be connected to this point to establish the combustion performance of the boiler. Checking/adjustment of this value is required in the following instances; replacement of gas valve, conversion to or from Natural Gas/LPG as part of the service schedule or if incorrect combustion is suspected (see section 9).

8.1.2 Maintenance

Before commencing any servicing or maintenance work, carry out an initial inspection of the system as follows:

- Inspect the flue, pipe work and electrical connections for indications of damage or deterioration.
- Inspect the air supply and ventilation arrangements of the installation.
- Check the heating and water system, in particular the condition of radiator valves, evidence of leakage from the heating system and dripping hot water taps.
- Carry out inspection or maintenance in accordance with table 8.1 below.

8.1.3 Checking the CO/CO₂ ratio



Note!

Checking/adjustment of the CO/CO₂ ratio is required in the following instances:

- replacement of gas valve,
- conversion to or from Natural Gas/LPG,
- or if an incorrect combustion is suspected.



Note!

The boiler is fitted with a flue gas analysis point. A suitable flue gas analyser can be connected to this point to establish the combustion performance of the boiler.

8 Inspection and maintenance

Overview of the inspection and maintenance tasks

No.	Activity	Inspection must be carried out each year	Maintenance must be carried out at regular intervals - but no longer than 5 years
1	Check the air flue gas installation for leaks and for proper fixation and ensure it is not blocked or damaged and is fitted correctly, complying with the relevant installation instructions.	x	x
2	Carry out a general inspection of the boiler for dirt and dust and clean as necessary.	x	x
3	Visually inspect the complete heat engine for its general condition and for signs of corrosion, sooting or other forms of damage. If damage is evident proceed to column 2.	x	x
4	Measure the gas flow rate during operation with maximum load. If the gas flow rate complies to the Table 5.2 continue with column 1, if not proceed to column 2.	x	x
5	Check the gas inlet working pressure operation with maximum load. If the gas inlet working pressure complies to the Table 5.1 continue with column 1, if not proceed to column 2.	x	x
6	Check combustion by measuring CO, CO ₂ and CO/CO ₂ . If the values are outside the tolerances of Table 9.1 proceed to maintenance column 2. You must not proceed with the maintenance if a new burner door seal kit is not available (Article No. 0020038679).	x	
7	Isolate the boiler from the power mains. Check whether the electrical plug connections and the other electrical connections are fitted tightly and correct them if necessary.	x	x
8	Close the gas isolator cock.		x
9	Remove the compact thermal module.		x
10	Check the integrity of all combustion circuit seals, especially the burner door seal. If there are any damages repair them before proceeding.		x
11	Clean the heat exchanger.		x
12	Check whether the burner is dirty and clean it if necessary.		x
13	Check the condensate siphon in the boiler, clean and fill if necessary.	x	x
14	Check the condensate ducts in the boiler and clean if necessary.	x	x
15	Install the compact thermal module. Caution: Use new seals and nuts!		x
16	Open the gas isolator cock, reconnect the boiler with the power mains and switch on the boiler.	x	x
17	Perform a test operation of the boiler and heating installation, including water heating and bleed again if necessary.	x	x
18	Check visually the ignition and burner performance.	x	x
19	Check the boiler for leaks of any kind (gas, flue gas, water, condensate) and rectify as necessary.	x	x
20	If you had problems with the CO, CO ₂ , CO/CO ₂ -values in Step 6 before the maintenance, check them again now (see Table 9.1). If they are outside of the tolerances of Table 9.1 make an adjustment, see section 9.1.		x
21	Complete the gas commission checklist (benchmark book).	x	x

Table 8.1 Inspection and maintenance steps

8.1.4 General

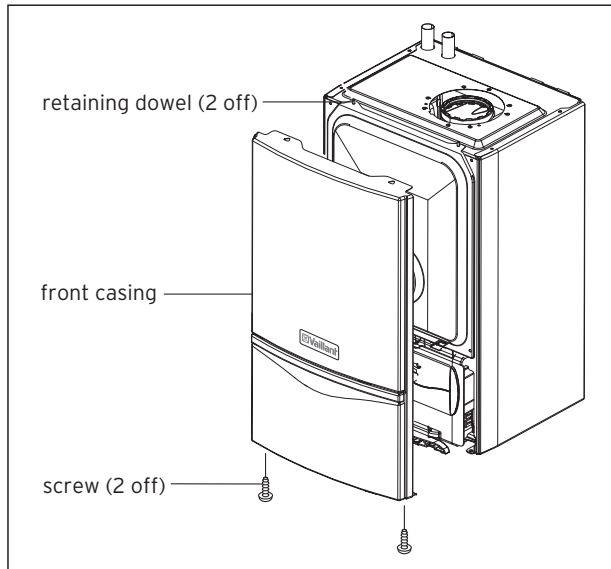

Fig. 8.1 Panels

All routine servicing requirements can be achieved by the removal of the front casing, inner case and chassis panel only.

- Remove the two screws on the underside of the front casing and lift off.
- Remove the two screws on the front of inner case and lift off, see fig 8.1.
- Drop down the electronics box into the service position.
- Remove the four screws from the chassis panel, see fig 8.2. Remove the chassis panel by pulling it out at the top from its retaining slots.

Note!
When replacing chassis front panel ensure the bottom fits behind lip.

Unless stated otherwise any part removed during servicing should be replaced in the reverse order to removal. With the appliance operational carry out the following functional checks:

1. Check the combustion, with a flue gas analyser, see section 9.
2. Should the combustion measurement or flame and gas valve be correct, then it is not necessary to remove the burner assembly for a service.
3. Check the operational performance of the central heating agrees with the technical specification.

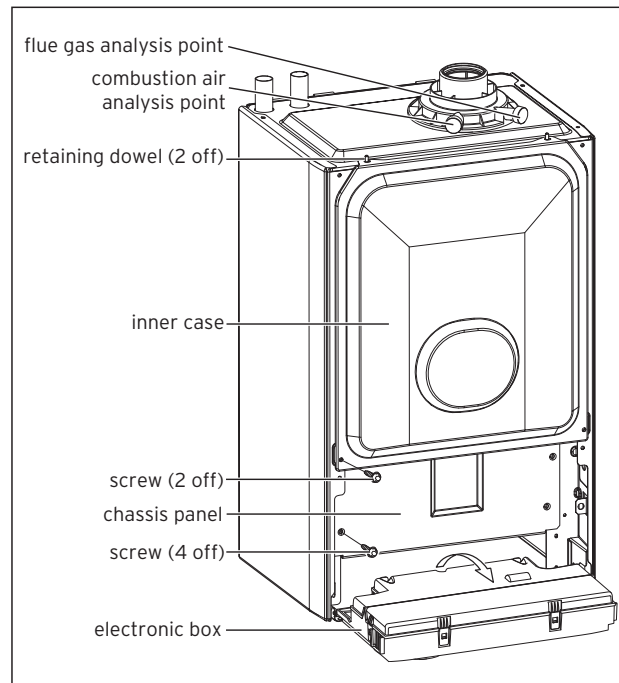

Fig. 8.2 Control panel

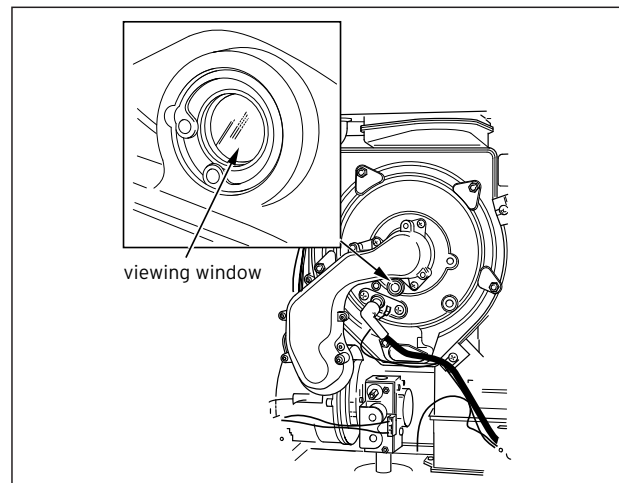

Fig. 8.3 Flame picture

8 Inspection and maintenance

8.1.5 Spark electrode

- Disconnect the ignition lead and earth lead from the igniter unit and two securing screws at the spark electrode.
- Withdraw the spark electrode carefully from the combustion chamber, see fig 8.4.
- Inspect the tips for damage.
- Clean away any debris and check the spark gap is 3.5 -4.5 mm.
- Check the electrode gasket for signs of damage and replace if necessary.

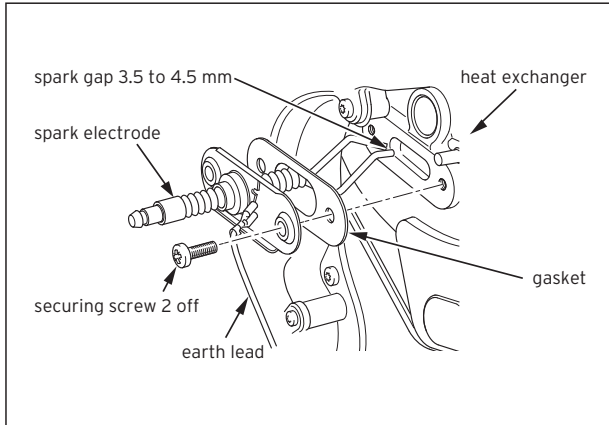

Fig. 8.4 Withdrawing the spark electrode

8.1.6 Removing the burner

Note!
If the functional checks did not indicate poor combustion then it is not necessary to service the burner.

Caution!
The burner door seal and combustion chamber burner door securing nuts on the burner module, see figs 8.6 and 8.7 must be replaced each time the module is removed for example during maintenance if the burner flange insulation shows any signs of damage or small cracks it must also be replaced. Isolate the gas supply at the gas service cock. Disconnect the gas supply at the gas service cock.

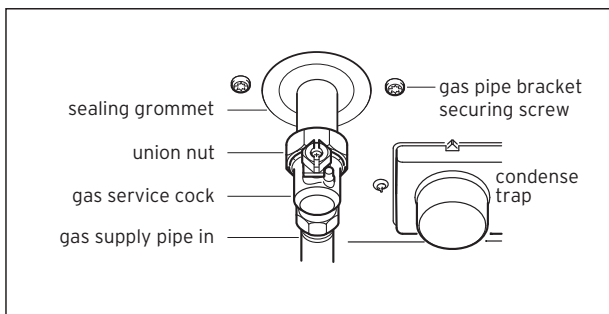

Fig. 8.5 Gas service cock

- Note!**
- Do not disconnect at the gas valve.
 - Remove the two gas pipe bracket securing screws from underside of inner case, see fig 8.5.
 - Drop down the electronics box into the service position.
 - Remove the four screws from the chassis front, see fig 8.2.
 - Remove the chassis front by pulling it out at the top from its retaining slots.

Note!
When replacing chassis front panel ensure the bottom fits behind lip.

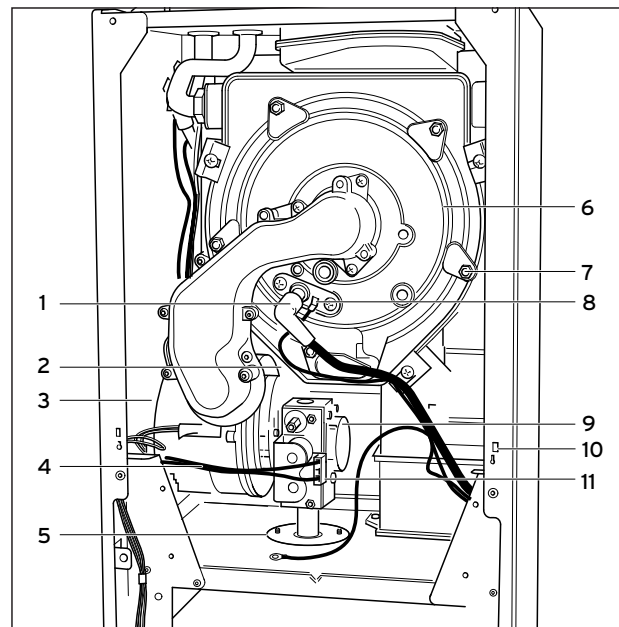

Fig. 8.6 Fan, gas valve and burner

- 1 Electrode connector
- 2 Ignition lead
- 3 Fan
- 4 Electrical lead
- 5 Gas pipe bracket
- 6 Burner door
- 7 Combustion chamber burner door securing nuts (5 off)
- 8 Earth spade connector
- 9 Gas valve
- 10 Chassis front retaining slots
- 11 Gas valve electrical plug

- Disconnect the gas valve electrical plug at the gas valve.
- Disconnect the electrical leads from the fan.
- Remove the five combustion chamber burner door securing nuts, these should be discarded and replaced with the new nyloc nuts supplied in the burner door seal kit.
- Gently remove the fan, gas valve and burner assembly from the combustion chamber complete with the gas pipe bracket and seal, see fig 8.6.

- Clean the burner with a soft brush taking great care not to damage the front insulation. DO NOT use wire or sharp instruments to clean the holes of the burner.
- Inspect the burner for any signs of damage.
- Remove and discard the burner door seal and replace with new, see fig 8.7.

Removal of the burner is not necessary during a normal service.

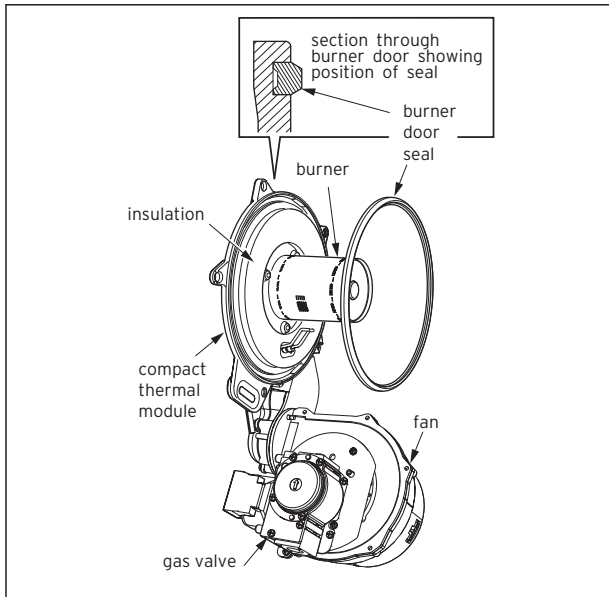

Fig. 8.7 Compact thermal module

Note!
If the burner has to be removed it will require a new gasket and nuts when refitted (Article No. 0020038670).

Note!
When replacing ensure that the sealing grommet, situated below the gas valve is correctly re-seated.

8.1.7 Combustion chamber and heat exchanger

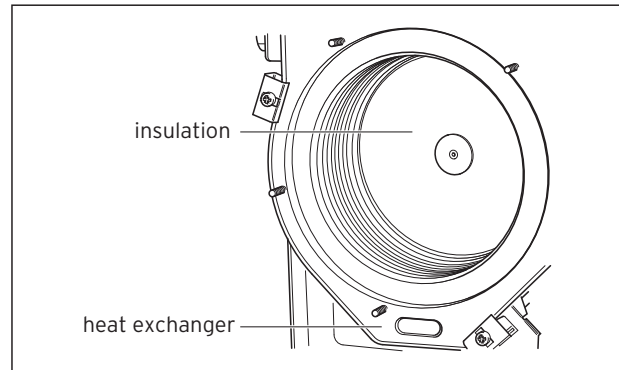

Fig. 8.8 Insulation

Remove loose debris from combustion chamber using a soft brush and vacuum cleaner. Carefully flush any remaining debris through the condensate trap (ensure the water is kept away from electrical components).

8.1.8 Condensate drain

The condensate drain does not normally need removing during servicing. To flush the condensate drain carefully pour water into the heat exchanger and check that water flows freely to drain. If the condensate drain is blocked, refer to parts replacement section 11 for removal.

8.1.9 Inner casing panel seal check

Check the condition of the seal, replace as required. To replace remove the old seal, thoroughly clean the casing surfaces. Fit the new seal, it is supplied to the correct length.

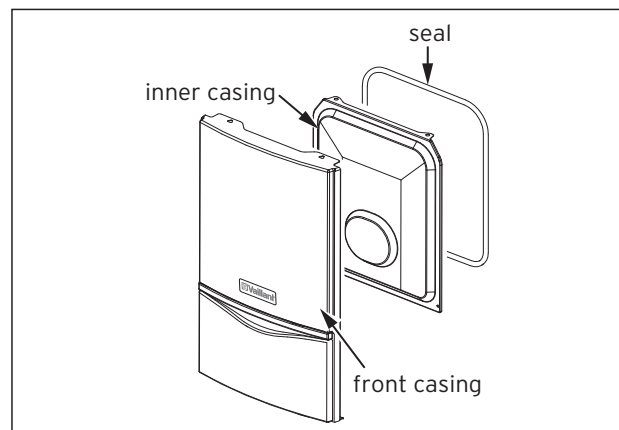

Fig. 8.9 Panels

8.1.10 Checking the expansion vessel (If fitted).

Note!
It is not necessary to perform this check every year a check every three years is sufficient.

- Release the pressure from the boiler.

8 Inspection and maintenance

9 Combustion analysis

- Remove valve cap from expansion vessel charge point.
- Check that the internal charge pressure of the expansion vessel is to the correct design pressure. If the pressure is lower than this the vessel should be repressurised using an air pump.
- Refit the valve cap.
- Re pressurise boiler and heating system.

8.1.11 Re commissioning the boiler

- Carry out electrical safety checks.
- Turn on the electrical supply.
- Open the boiler CH service valves.
- Carry out function checks of boiler operation as previously detailed.
- Check gas rate as previously detailed.
- Check for water leaks.
- Refit case, ensuring that a good seal is obtained.

8.1.12 Test operation

Always perform the following checks after completing any maintenance task:

- Commission the appliance according to the relevant operating manual.
- Check the appliance for gas and water leaks.
- Check the air/flue gas system for leaks, check its fastening
- Check for ignition and an even flame on the burner.
- Check that the heating system is working.
- Fill out the Benchmark gas boiler commissioning checklist at the rear of this guide.

9 Combustion analysis

 **Note!**

The boiler is fitted with a flue gas analysis point. A suitable flue gas analyser can be connected to this point to establish the combustion performance of the boiler.

9.1 Check CO₂ content

Refer to table 9.1 and if necessary set (air-ratio adjustment).

 **Note!**

Combustion analysis must be carried out at annual service if a flue gas analyser is available, if no analyser is available then visual checks should be carried out as per service schedule. Checking/adjustment of this value is also required in the following instances: replacement of gas valve, conversion to or from natural gas/LPG or if incorrect combustion is suspected!

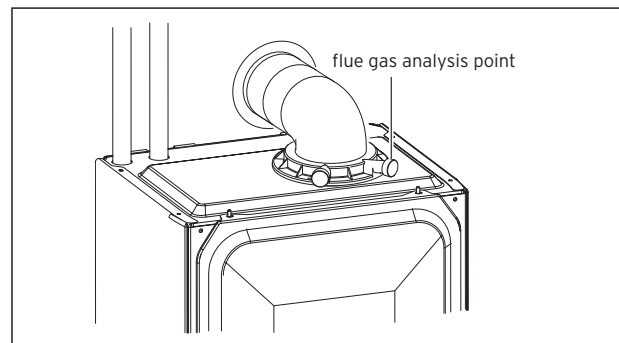

Fig. 9.1 Analysis point

- Remove the front and inner cover.
- To correct combustion follow the procedure as listed below.
- Ensure that the gas supply pressure is correct (see table 5.1)
- The gas inlet working pressure can be checked at the pressure test point on the gas valve (fig 5.3.).
- Turn gas supply on.
- Ensure there is an external heat demand.
- Enter the test programs by holding the "+" key, see fig 6.2. and turning power on.
- Press "+" until "P.1" is displayed for max rate.
- Press "i" to operate appliance in this mode.
- Allow appliance to stabilise.
- Measure the CO₂ at the combustion analysis point point, see fig 9.1.
- Check CO₂ value (for case off) as stated in table 9.1 for the boiler installed.

Model	Nat. Gas			LPG			
	G20 % CO ₂ after 5 mins at full load		Maximum CO/CO ₂ ratio	G31 % CO ₂ after 5 mins at full load		Throttle Adjustment	Maximum CO/CO ₂ ratio
	Case off	Case on		Case off	Case on		
ecoTEC plus 415	9.1 + 0.2 - 0.5	9.3 + 0.2 - 0.5	<0.0026	10.1 + 0.5 - 0.5	10.3 + 0.5 - 0.5	5 turns	<0.0026
ecoTEC plus 418	9.1 + 0.2 - 0.5	9.3 + 0.2 - 0.5	<0.0026	10.1 + 0.0 - 1.0	10.3 + 0.0 - 1.0	5 turns	<0.0026
ecoTEC plus 428	9.1 + 0.2 - 0.5	9.3 + 0.2 - 0.5	<0.0026	10.5 + 0.3 - 0.8	10.7 + 0.3 - 0.8	5 turns	<0.0026
ecoTEC plus 438	8.8 + 0.2 - 0.5	9.0 + 0.2 - 0.5	<0.0026	9.8 + 0.2 - 0.8	10.0 + 0.2 - 0.8	8 turns	<0.0026

Table 9.1 CO/CO₂ ratio

- If required, using a screwdriver, adjust the "A" throttle to obtain correct value. (rotating anti-clockwise to increase). Appliance will remain in this mode for 15 minutes or exit by pressing "i" and "+" simultaneously.
- Repeat the process above and select "P.2" for min rate.
- Press "i" to operate appliance in this mode.
- Allow appliance to stabilise.
- Check CO₂ value (for case off) as stated in table 9.1 for the boiler installed.
- If required, using a 2mm Allen key, adjust the "B" offset to obtain correct value (rotating clockwise to increase). When complete repeat the P1 Max rate setting to ensure it is correct following this.
- After checking the combustion, exit by pressing "i" and "+" simultaneously
- Refit the chassis panel and the inner case. (Note the CO₂ will increase slightly).



Note!

Only for natural gas:

Adjust only in increments of 1/8 turn and wait approx. 1 minute after each adjustment until the value stabilises.

Only for liquid gas:

Adjust only in very small increments (approx. 1/16 turn), and wait approx. 1 minute after each adjustment until the value stabilises.

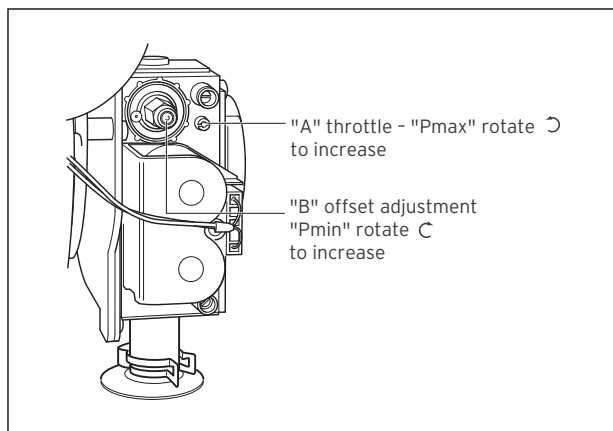

Fig. 9.2 Gas control valve

10 Troubleshooting

10.1 Logical fault finding procedure

These checks must be carried out before attempting to use the fault finding guide.

1. Carry out electrical safety checks (see section 4 'Wiring system').
2. Check that the external electricity supply to the boiler is on, and a supply of 230 V~ is present between boiler terminals 'L' and 'N'.
3. Check that the gas supply to the boiler is on, that it has been correctly purged and that an inlet pressure of 20 mbar is available at the gas valve. (See section 5 'Gas Supply').
4. Ensure the heating system is full of water and the system design pressure is attained. (sealed systems only). If not, refill and vent the system. Ensure any flow and return isolating valves (if fitted) are fully open.
5. Set the central heating temperature to maximum.
6. Set the domestic hot water temperature to maximum (Only if additional Vaillant accessories are fitted).
7. Check that all external controls are on and calling for heat (if no external controls are fitted, boiler terminals 3 and 4 must be linked). Check that the boiler anti cycling economiser is not engaged.

10.1.1 Status codes

The status codes that you can see on the display provides information about the current operating condition of the appliance.

The display of the status codes can be called as follows:

- Press the "i" key.
The display shows the status code, e.g. S.4 for "Burner mode - Heating". The display of the status codes can be cancelled as follows:
- Press the "i" key.
- Do not press any key for approx. 4 minutes. The current heating flow temperature appears in the display again.

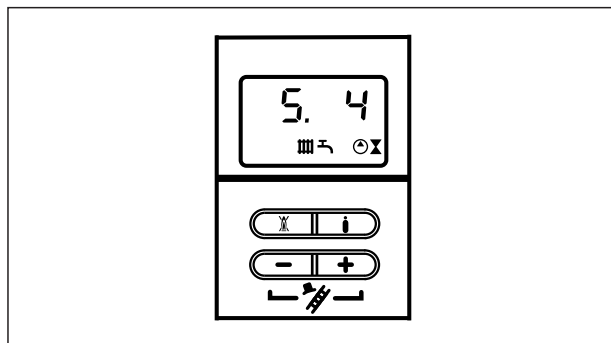



Fig. 10.1 Display of status codes

10.1.2 Diagnostic codes

In the diagnostic mode, you can change certain parameters or display more information. The diagnostic information is divided into two diagnostic levels. The second diagnostic level can be reached only after entering a password.

Display	Meaning
Heating mode (all models)	
S. 0	No heat demand
S. 1	Fan running
S. 2	Water pump running
S. 3	Ignition sequence
S. 4	Burner ignited
S. 5	Fan and pump running
S. 6	Fan over run
S. 7	Pump over run
S. 8	Anti cycling mode
Domestic hot water mode (when accessories are fitted)	
S.20	Warmstart demand
S.21	Fan running
S.22	Pump running
S.23	Ignition sequence
S.24	Burner ignited
S.25	Fan and water pump running
S.26	Fan over run
S.27	Pump over run
S.28	Anti cycling mode
Charge hot water cylinder (when accessories are fitted)	
S.20	Warmstart demand
S.21	Fan running
S.22	Pump running
S.23	Ignition sequence
S.24	Burner ignited
S.25	Fan and water pump running
S.26	Fan over run
S.27	Pump over run
S.28	Anti cycling mode
All boilers:	
S.30	No heating demand from external controls (clamp 3-4 open)
S.31	Central heating thermostat knob turned off or no heat demand by the eBUS control unit
S.32	Heat exchanger antifreeze active, as fan speed variation is too high. Appliance is within the waiting time of the operation block function
S.34	Anti frost mode active
S.36	No heating demand from low voltage controls (clamp 7-8-9)
S.41	Water pressure > 2,9 bar
S.42	Response from accessory module or defective condensate pump is blocking burner operation
S.53	Appliance is within the waiting period of the operation block function due to water shortage (VL-RL spread too big)
S.54	Appliance is within the waiting period of the operation block function due to water shortage (temperature gradient)
S.96	Return-sensor check is running, demand (DHW or heating) is blocked
S.98	Flow-/Return-sensor check is running, demand (DHW or heating) is blocked

Table 10.1 Status codes

 **Caution!**
Access to the second diagnostic level must be used exclusively by a qualified technician.

First Diagnostic level

- Press the "i" and "+" keys simultaneously. The display shows "d.0".
- Use the "+" or "-" keys to scroll through the desired diagnostic numbers of the first diagnostic level (see table 10.2).
- Press the "i" key. The display shows the relevant diagnostic information.
- If necessary, use the "+" or "-" keys to change the value (display flashes).
- Save the new value by holding down the "i" key for approx. 5 seconds until the display no longer flashes. You can end the diagnostic mode as follows:• Press the "i" and "+" keys simultaneously.

- Do not press any key for approx. 4 minutes. The current heating flow temperature appears in the display again.

Second diagnostic level

- As described above in the first diagnostic level, scroll through the diagnostic number d.97.
- Change the displayed value to 17 (password) and press the "i" button. You are now in the second diagnostic level where all information from the first diagnostic level (see table 10.2) and the second diagnostic level (see table 10.3) is displayed. Scrolling and changing values and exiting the diagnostic mode is done as described in the first diagnostic level.

 **Note!**
After exiting the second diagnostic level, if you press "i" and "+" within 4 minutes, you will directly reach the second diagnostic level without having to enter the password again.

Display	Meaning	Display value/adjustable value
d. 0	Heating part load	Adjustable heating part load in kW (factory setting: max. output)
d. 1	Water pump over run time for heating mode	2 - 60 min (factory setting: 5 min)
d. 2	Max. burner anti cycling period at 20 °C Flow temperature	2 - 60 min (factory setting: 20 min)
d. 3	Hot water flow temperature reading (when accessories are fitted)	in °C
d. 4	Current temperature for warm start sensor (when accessories are fitted) Current storage tank sensor	in °C
d. 5	Flow temperature target value or return target value when return regulation is set.	in °C, max. the value set in d.71 Limited by the eBUS controller (if an eBUS controller is connected)
d. 6	Hot water temperature target value	in °C, 35 to 65 °C
d. 7	Warm start temperature target value (when accessories are fitted) Storage temperature target value (system boiler only)	in °C, 40 to 65 °C in °C, 15 °C for left stop, then 40 to 70 °C
d. 8	External controls heat demand (terminals 3-4)	0 = open (no heat request) 1 = closed (heat request)
d. 9	Flow target temperature from external analogue regulator to terminal 7-8-9/eBUS	in °C, minimum from ext. eBUS target value and target value terminal 7
d.10	Status internal heating pump	1 = on, 0 = off
d.11	Status external heating pump	1 to 100 = on, 0 = off
d.12	Cylinder charging pump (via accessory module)	1 to 100 = on, 0 = off
d.13	Hot water circulation pump (via accessory module)	1 to 100 = on, 0 = off
d.22	Hot water demand	1 = on, 0 = off
d.23	Summer/Winter function	1 = Winter, 0 = Summer
d.25	Hot water activation via eBUS Control	1 = yes, 0 = no
d.30	Control signal for both gas valves	1 = on, 0 = off
d.33	Fan speed target value	in rpm/10
d.34	Fan speed actual value	in rpm/10
d.35	Position of diverter valve (when accessories are fitted)	0 = Heating; 100 = Hot water; 40 = Centre position
d.36	Hot water flow sensor	in l/min
d.40	Flow temperature Actual value	in °C
d.41	Return temperature Actual value	in °C
d.44	Digitised ionisation potential	Display range of 0 to 102, > 80 no flame, < 40 even flame
d.47	Outside temperature (with weather compensating Vaillant controller only)	Actual value in °C
d.67	Remaining burner anti cycling time	in min
d.76	Appliance variant (device specific number)	00 to 99
d.90	Digital regulator status	1 = identified, 0 = unidentified (eBUS Address <=10)
d.91	DCF status with connected external probe with DCF77 receiver	0 = no reception, 1 = reception, 2 = synchronised, 3 = valid
d.97	Activation of the second diagnostic level	Password: 17

Table 10.2 Diagnostics codes of the first diagnostic level

10 Troubleshooting

Display	Meaning	Display value/adjustable value
d.17	Heating flow/return regulation change over	0 = flow, 1 = return (factory setting: 0)
d.18	Pump mode (return)	0 = return, 1 = nonstop, 2 = winter (factory setting: 0)
d.19	Operating modes of the two-speed heating pump	0 = pre ignition speed 1, hot water or heating speed 2, overrun speed 1 1 = pre ignition speed 1, hot water speed 2, heating speed 1 overrun speed 1 2 = like 1, but speed in heating mode dependent on heating part load d. 0 (if d.0 is below 60% of full load, then pump speed 1, other-wise speed 2) 3 = always speed 2 (factory setting: 2)
d.20	Maximum set value for target cylinder temperature (system boilers only)	Setting range: 50 to 70 °C (factory setting: 65 °C)
d.27	Switching accessory relay 1 in the accessory module	1 = Circulation pump (default) - 2 = Ext. pump 3 = Storage charging pump - 4 = Flue gas flap/extractor hood 5 = External gas valve - 6 = External error message
d.28	Switching accessory relay 2 in the accessory module	1 = Circulation pump - 2 = Ext. pump (default) 3 = Storage charging pump - 4 = Flue gas flap/extractor hood 5 = External gas valve - 6 = External error message
d.50	Offset for minimum speed	in rpm/10, adjustment range: 0 to 300
d.51	Offset for maximum speed	in rpm/10, adjustment range: -99 to 0
d.58	From the third quarter of 2006: Activation of solar reheating	Setting range: 0 to 30 = solar reheating disabled (factory setting) 3 = activation of min. hot water target value = 60 °C for solar reheating
d.60	Number of safety temperature limiter cut offs	Quantity
d.61	Number of lock outs	Number of unsuccessful ignitions in the last attempt
d.64	Average ignition time	in seconds
d.65	Maximum ignition time	in seconds
d.68	Unsuccessful ignitions in the first attempt	Quantity
d.69	Unsuccessful ignitions in the second attempt	Quantity
d.70	Set diverter valve position	0 = Normal mode (factory setting) 1 = Centre position 2 = permanent heating position
d.71	Maximum setting of heater control knob	Adjustment range in °C: 40 to 85 (Factory setting: 75)
d.72	Pump overrun time after warm start (combination boilers only) or charging an electronically controlled hot water storage through C1-C2 (system boilers only)	Adjustment range in sec: 0, 10, 20 to 600 Factory setting (when accessories are fitted): 80 Factory setting for system boilers: 300
d.73	Offset for warm start target value (when accessories are fitted)	Adjustment range: -15 K to +5 K (Factory setting: OK)
d.75	Maximum charging time for a storage without own controller (system boilers only)	Adjustment range in min: 20, 21, 22 to 90 (Factory setting: 45)
d.77	Storage partial load (storage charging capacity limit, system boilers only)	Adjustment range in kW: appliance specific Factory setting: max output
d.78	Storage charging temperature limit (target flow temperature in storage mode, system boilers only)	Adjustment range in °C 55 to 90 (Factory setting: 80)
d.80	Heating operating hours	in h1)
d.81	Water heating operating hours (when accessories are fitted)	in h1)
d.82	Cycles in heating mode	Quantity/1001) (3 corresponds 300)
d.83	Cycles in hot water operation	Quantity/1001) (3 corresponds 300)
d.84	Maintenance indicator: Number of hours until the next maintenance	Adjustment range: 0 to 3000 h and "-" for disabled Factory setting: "-" (300 corresponds to 3000 h)
d.93	DSN appliance variant setting	Adjustment range: 0 to 99
d.96	Factory setting	1 = Resetting adjustable parameters to factory setting

Table 10.3 Diagnostics codes of the second diagnostic level

1) Five-digit numbers are saved with the diagnostics codes 80 to 83. If d.80, for example, is selected, only the first two digits of the number are displayed (e. g. 10). The display switches to the last three digits (e. g. 947) by pressing "i". In this example the number of operating hours of the heating is 10947 h. The display returns to the selected diagnostics item by pressing "i" again.

10.1.3 Fault codes

Fault codes take priority over all other display functions in the event of a system fault occurring. If multiple faults occur, the corresponding fault codes are displayed alternately for about two seconds each.

- Press the "i" and "-" buttons simultaneously.
- Use the "+" button to scroll back through the list of memorised errors. To cancel fault error memory display mode, proceed as follows:
- Press the "i" button below the display or
- Do not touch any key for about four minutes. The display will now revert back to showing the current flow temperature.

10.1.4 Fault memory

The fault memory stores details of the ten most recent faults.

Code	Meaning	Cause
F. 0	Flow-NTC open circuit	NTC broken, NTC cable broken, Defective connection at NTC, Defective connection at electronics
F. 1	Return-NTC open circuit	NTC broken, NTC cable broken, Defective connection at NTC, Defective connection at electronics
F.10	Flow NTC short circuit	NTC defective, short circuit in cable harness, cable/casing short cut
F.11	Return NTC short circuit	NTC defective, short circuit in cable harness, cable/casing short cut
F.13	Tank NTC short circuit	NTC defective, short circuit in cable harness, cable/casing short cut
F.20	Safety temperature limiter by NTC activated	Flow-NTC not correctly thermal-connected or defective; appliance does not shut down
F.22	Dry fire	Too little water in the appliance, water pressure sensor defective, cable to pump or water sensor defective, pump blocked or defective, pump output too low
F.23	Water shortage, temperature difference between flow and return NTC too large	Pump blocked or defective, pump output too low, flow and return NTC interchanged
F.24	Water shortage, temperature rise too quick	Pump blocked, insufficient pump output, air in appliance, water pressure too low
F.27	Incorrect sensing of flame	Flame detector defective
F.28	Appliance does not start: Attempts to ignite during start failed	Faults in the gas supply such as:- - Gas meter or gas pressure detector defective - Air in gas- Gas flow pressure too low - Fire protection tap has disengaged Faults in the gas valve, wrong gas setting, igniter (ignition transformer, ignition cable, ignition plug) defective, ionisation current stopped (cable, electrode), faulty earthing in appliance, electronics defective
F.29	Flame goes off during operation and subsequent	ignition attempts failed Gas supply temporarily stopped, faulty earthing of appliance
F.32	Fan speed variation	Fan blocked, plug not inserted correctly on fan, hall sensor defective, fault in cable harness, electronics defective
F.49	eBUS under voltage	Short circuit on eBUS, overload on eBUS or two power sources on eBUS with different polarity
F.61	Gas-valve control defective	Short circuit/earth (ground) leak in cable harness to gas valves, gas valve assembly defective (earth/ground leak from coils), electronic control system defective
F.62	Gas valve shut off delay	Gas valve leaking, electronics defective
F.63	EEPROM error	Electronics defective
F.64	Electronics/NTC fault	Short-circuit in flow or return NTC or electronics defective
F.65	Electronics temperature too high	Electronics too hot due to external effect, electronics defective
F.67	Flame detector input signal is outside the limits (0 or 5 V)	Electronics defective
F.70	No valid DSN in display and/or main board	Spare part failure display and main board interchanged at same time and device specific number not adjusted
F.71	Flow NTC reports constant value (stuck at)	Flow NTC is defective
F.72	Flow and/or return NTC fault	Flow and/or return NTC is defective (tolerances too big)
F.73	Water pressure sensor signal out of range (too low)	Spare part failure display and main board interchanged at same time and device specific number not adjusted
F.75	No pressure rise was detected on turning on the pump	Water pressure sensor or/and pump defective Air in the heating system, quick bleeder defective Too little water in appliance; check adjustable by-pass; connect external expansion vessel to return
F.76	Overheating protection on primary heat exchanger triggered	Cable or cable connection of fuse in the primary heat exchanger defective, or primary heat exchanger defective
F.77	Condensate pump or feedback of accessories blocks heating	Condensate pump defective or flume flap feedback triggered
F.78	Wrong configuration with accessory	link box VR65 connected to combination boiler
con	No communication to main board	Connection error display main board

Table 10.4 Error codes

10 Troubleshooting

10.2 Test programs

Special functions can be triggered on the appliances by activating various test programs.

These programs are given in detail in the Table 10.5.

- The test programs P.0 to P.6 will be started when "Power ON" is turned on and the "+" key is pressed for 5 s. The display shows "P.0".



Note!

If the power switch is out of reach, alternatively press the reset button  then hold the "+" key until "PO" is displayed.

- Press the "+" key to start counting the test number upwards.
- Press the "i" to operate the appliance now and to start the test program.
- Press "j" and "+" simultaneously to exit the test programs. You can also exit the test programs by not pressing any key for 15 minutes.

Display	Meaning
P.0	Bleeding test program. The heating circuit and hot water circuit (when accessories are fitted) is bled via the automatic air vent (the cap on the automatic air vent must be loosened).
P.1	Test program where the appliance is operated in full load after successful ignition
P.2	Test program where the appliance is operated with minimum gas volume (ignition gas volume) after successful ignition
P.3	Not available
P.4	Not available
P.5	Test program for the safety temperature limit check; appliance heats up by by-passing a regulating shut down through the flow regulator until the shut off temperature of 97 °C is achieved.
P.6	Filling test program. The diverter valve moves to the centre position

Table 10.5 Test programs

10.3 Resetting parameter to factory settings

Besides the option to reset individual parameters manually to the factory settings specified in tables 10.2 and 10.3, you can also reset all parameters simultaneously.

- In the second diagnostic level, under the diagnostic number "d.96" change the value to 1 (see section 10.1.2). The parameters of all adjustable diagnostic numbers now correspond to the factory settings.

11 Parts replacement

The tasks listed below in this section may be carried out only by a competent person approved at the time by the Health and Safety Executive as stated in the Gas Safety (Installation and Use) Regulations 1998..

- Only use genuine spare parts for repairs.
- Make sure the parts are correctly fitted and that their original position and alignment are retained.

11.1 Safety instructions



Danger!

Each time the components are replaced, comply with the safety instructions below for your own safety and to avoid damage to the appliance!

- Put the appliance out of operation.



Note!

Before starting any maintenance work: Isolate the mains electricity supply by disconnecting the plug at the socket outlet (if there is only an isolating switch remove the fuse from the switch).

- Close the service valve in the gas supply.
- Isolate the boiler flow and return if possible.
- Empty the appliance if you want to replace water bearing components of the appliance!
- Make sure that no water drops on live components (e.g. switch box etc.)!
- Use only new seals and O-rings!
- After completing the work, check for gas leaks and perform a function check (see section 7)!
- Always check earth continuity, polarity and resistance to earth with a multimeter after any service work and after exchanging any electrical component.

11.2 Replacing the burner.

For access refer to section 8.1.4.

Remove the burner refer to section 8.1.6

11.3 Replacing the gas valve

For access refer to section 8.1.4.

- Remove the gas valve, fan and burner refer to the relevant parts of section 8.1.6.
- Before removing the gas valve note its position on the fan.
- Remove the three securing screws, which fix the gas valve, plastic swirl plate to the venturi on the fan.
- Remove the gas valve.
- Remove the gas supply pipe from the gas valve.
- When refitting the gas valve take care as it can be fitted more than one way.

After assembly test for gas soundness and purge in accordance with the current issue of BS6891 or in IE, the current edition of I.S.813 "Domestic Gas Installations".

11.4 Replacing the fan

- Remove the gas valve refer to section 11.3.
- Remove the venturi plate secured with three screws
- Remove the two screws securing the fan to the gas manifold, see fig 11.1.

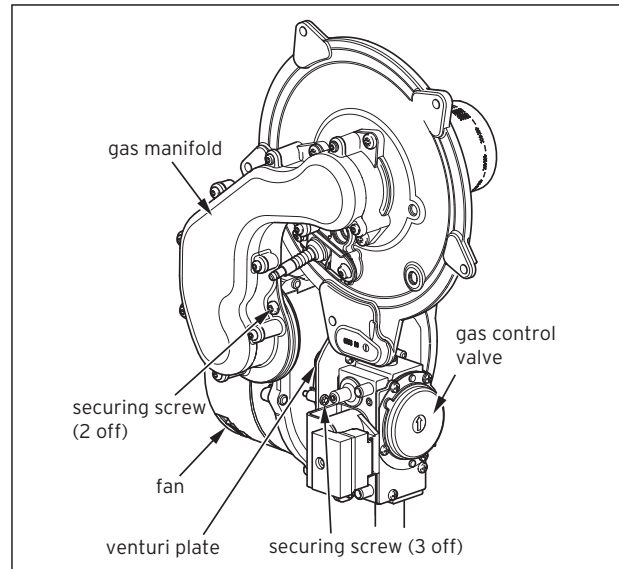

Fig. 11.1 Fan removal

Check the gasket and replace if necessary.



Note!

The ecoTEC plus 428 and 438 fan is secured through an extension piece with two securing screws, check and replace any seals or gaskets if necessary.

11.5 Replacing the heat exchanger

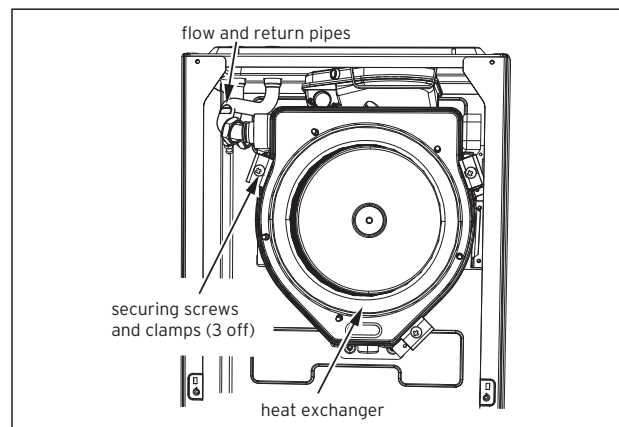

Fig. 11.2 Heat exchanger removal

For access refer to section 8.1.4.

- Remove the gas valve, fan and burner refer to the relevant parts of section 8.1.6.
- Drain the boiler.

11 Parts replacement

- Remove the clip securing the clear condense pipe to heat exchanger.
- Pull to remove clamps (two at the top and one at the bottom) to remove the heat exchanger, see fig 11.2.

 **Note!**
There will be water in the heat exchanger.

- Remove clear condense pipe connector from bottom of heat exchanger.

11.6 Replacing the condense trap and siphonic drain

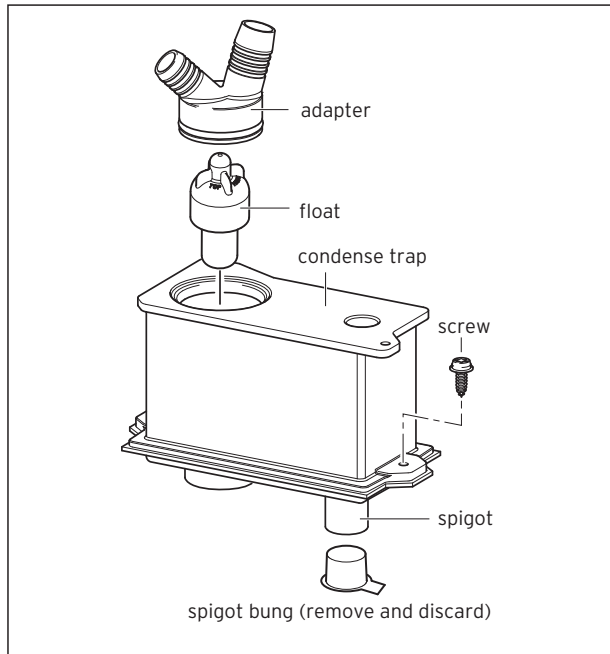

Fig. 11.3 Condense trap

- Remove the clips securing the flexible tubes to the adapter by twisting the clips slightly to disengage the clip jaws from each other.
- Remove flexible tubes from adapter.
- Lift off the adapter.
- Remove the drain connection downstream of the condense trap.
- Remove the two condense trap securing screws.
- Lift up and carefully remove the condense trap taking care not to spill any water which may be left in the unit. As the unit is lifted remove the flexible pipe on the outlet.
- Remove any solids found.

Before removing the float note it's orientation.

- Remove the float to clean it.
- Flush water through the trap to remove any remaining solids.
- Check for any debris in the outlet pipe of the condensate drain and clean as necessary.
- Reassemble and refit the condense trap.

 **Note!**
If a replacement trap is required remove spigot bung before fitting condensate drain connection.

Using a suitable container, flush the heat exchanger until the water appears clear in the container. Reassemble adapter.

11.7 Replacing electronics and display

 **Danger!**
Before replacing the component, comply with the safety instructions in Section 11.1.

- Comply with the assembly and installation manuals provided with the spare parts.

Replacing display or electronics

If you are replacing only one of the two components, the parameter adjustment functions automatically. On turning on the appliance, the new component takes over the previously set parameters from the components that are not replaced.

Replacing display and electronics

When replacing both components, after being turned on, the appliance goes to fault and displays the error message "F70".

- In the second diagnostic level, under the diagnostic number "d.93" enter the number of appliance variant according to Table 11.1 (see section 10.1.2).

Appliance	Device specific number
ecoTEC plus 415	11
ecoTEC plus 418	12
ecoTEC plus 428	13
ecoTEC plus 438	14

Table 11.1 Device specific numbers

The electronics is now set to the appliance type and the parameters of all adjustable diagnostics numbers correspond to the factory settings.

12 Recycling and disposal

The design of all Vaillant products takes into account the subsequent recycling and/or eventual safe scrapping of each component used. Vaillant's in-house rules set strict standards in this respect. The selection process used for choosing raw materials includes full consideration of their recycling characteristics, and of the breakdown and separation properties of sub assemblies. We also take fully into account the environmental and health hazards involved in recycling and in the disposal of non-reusable waste items.

12.1 Appliance

The Vaillant ecoTEC plus consists largely (92 %) of metal components designed for eventual recycling by incorporation into the smelting process of a steelworks. This gives these parts virtually unlimited scope for subsequent re-use. All plastic materials are duly identified to facilitate sorting and separation when the time comes to recycle the unit.

12.2 Packaging

Vaillant endeavours to keep the amount of transport packaging used for its equipment to the bare minimum necessary. Subsequent re-use is taken into account when selecting packaging materials. High-quality cardboard has long been a valuable secondary raw material for the card and paper industry. The sections of EPS (Styropor®) are required in order to protect equipment in transit. EPS is 100 % recyclable and CFC-free. The foil-wrapping and securing straps are likewise made of recyclable plastic.

13 Factory guarantee and Vaillant service

13.1 Factory guarantee

Two year guarantee for ecoTEC plus appliances

Vaillant provides this appliance with a parts and labour guarantee against defects that may occur within twenty-four months of the installation date.

For the 2nd year of the guarantee to be valid an annual service must be carried out by a competent person approved at the time by the Health and Safety Executive one year after installation.

The cost of this annual service is not included in the guarantee.

Registering with us

Registration is simple. Just complete the Guarantee Registration Card and return to Vaillant within 30 days of installation. Your details will then be automatically registered within the Vaillant scheme.

Immediate help

If your Vaillant boiler develops a fault your first action should be to contact your installer, as his professional assessment is needed under the terms of our Guarantee. If you are unable to contact your installer, phone Vaillant Service Solutions: 0870 6060 777

13.2 Vaillant service

To ensure regular servicing, it is strongly recommended that arrangements are made for a Maintenance Agreement. Please contact Vaillant Service Solutions (0870 6060 777) for further details.

14 Appendix



EC declaration of conformity

Name and Address of the manufacturer: **Vaillant GmbH
Berghauser Str. 40
42859 Remscheid**

Identification of product: Vaillant ecoTEC plus
Condensing - Open Vented Boilers

Appliance type: ecoTEC plus 415
ecoTEC plus 418
ecoTEC plus 428
ecoTEC plus 438

The appliance types satisfy the essential requirements of the relevant directives and Standards:

90/396/EEC including amendments "Directive on the approximation of the law of the member states relating to appliances burning gaseous fuels"	Designed and built to CE-type examination certificate: PIN no: 87B042
92/42/EEC including amendments "Directive of efficiency relating to boiler burning gaseous fuels"	Designed and built according to European Standards:
73/23/EEC including amendments "Directive on the harmonization of the laws of Member States relating to electrical equipment designed for use within certain voltage limits"	EN 483 EN 677 EN 625 EN 60335-1 EN 60529 EN 50165
89/336/EEC including amendments "Directive on the approximation of the law of the member states relating to electromagnetic compatibility "	EN 55014 EN 61000-3-2 EN 61000-3-3

Any change to the appliance and/or any use not according to the instructions will lead to the invalidation of this Declaration of Conformity

Beiper, July 2006
(place, date)

Program Manager
S. Keeton

Certification Manager
A. Beardsley

Vaillant GmbH
Berghauser Str. 40 ■ D-42859 Remscheid ■ main phone no. +49 21 91/18-0 ■ Telefax +49 21 91/18-28 10
Ltd. company ■ Registered office: Remscheid ■ Registry court: Amtsgericht Wuppertal HRB 11775
Directors: Dr. Michel Brosset, Claes Göransson ■ Chairman of the Supervisory Board: Gert Krüger
Commerzbank Remscheid (code 340 400 49) account no. 621 833 300 ■ USt.-Ident-Nr. DE 811142240
HiWork Data/CE Data/ecoTEC plus Dec of Conf.doc/10.12.2001/ahr

Vaillant05

Installation, Commissioning and Service Record



Please affix the label from the rear cover of the control box over this area.

PEEL OFF

COMMISSIONING CHECKLIST GAS BOILER SYSTEM

This Commissioning Checklist is to be completed in full by the competent person who commissioned the boiler as a means of demonstrating compliance with the appropriate Building Regulations and then handed to the customer to keep for future reference.

Failure to install and commission this equipment to the manufacturer's instructions will invalidate the warranty but does not affect statutory rights.

Customer Name _____ Telephone Number _____
 Address _____
 Commissioned by (print name) _____ Engineer ID Number _____
 Company Name _____ Telephone Number _____
 Company Address _____
 Commissioning Date _____

To be completed by the customer on receipt of a Building Regulations Compliance Certificate*:

Building Regulations Notification Number (if applicable) _____

CONTROLS Tick the appropriate boxes

Time and Temperature Control to Heating	Room Thermostat and Programmer/Timer <input type="checkbox"/>	Programmable Room Thermostat <input type="checkbox"/>	Load/Weather Compensation <input type="checkbox"/>	Optimum Start Control <input type="checkbox"/>
Time and Temperature Control to Hot Water	Cylinder Thermostat and Programmer/Timer <input type="checkbox"/>		Combination Boiler <input type="checkbox"/>	
Heating Zone Valves	Fitted <input type="checkbox"/>		Not Required <input type="checkbox"/>	
Hot Water Zone Valves	Fitted <input type="checkbox"/>		Not Required <input type="checkbox"/>	
Thermostatic Radiator Valves	Fitted <input type="checkbox"/>		Not Required <input type="checkbox"/>	
Automatic Bypass to System	Fitted <input type="checkbox"/>		Not Required <input type="checkbox"/>	
Boiler Interlock				Provided <input type="checkbox"/>

ALL SYSTEMS

The system has been flushed and cleaned in accordance with BS7593 and boiler manufacturer's instructions Yes

What system cleaner was used? _____

What inhibitor was used? _____ Quantity litres

CENTRAL HEATING MODE Measure and Record:

Gas Rate m³/hr OR ft³/hr

Burner Operating Pressure (if applicable) mbar OR Gas Inlet Pressure mbar

Central Heating Flow Temperature °C

Central Heating Return Temperature °C

COMBINATION BOILERS ONLY

Is the installation in a hard water area (above 200ppm)? Yes No

If yes, has a water scale reducer been fitted? Yes No

What type of scale reducer has been fitted? _____

DOMESTIC HOT WATER MODE Measure and Record:

Gas Rate m³/hr OR ft³/hr

Burner Operating Pressure (at maximum rate) mbar OR Gas Inlet Pressure (at maximum rate) mbar

Cold Water Inlet Temperature °C

Hot water has been checked at all outlets Yes Temperature °C

Water Flow Rate l/min

CONDENSING BOILERS ONLY

The condensate drain has been installed in accordance with the manufacturer's instructions and/or BS5546/BS6798 Yes

ALL INSTALLATIONS

If required by the manufacturer, record the following CO₂ % OR CO ppm OR CO/CO₂ Ratio

The heating and hot water system complies with the appropriate Building Regulations Yes

The boiler and associated products have been installed and commissioned in accordance with the manufacturer's instructions Yes

The operation of the boiler and system controls have been demonstrated to and understood by the customer Yes

The manufacturer's literature, including Benchmark Checklist and Service Record, has been explained and left with the customer Yes

Commissioning Engineer's Signature _____

Customer's Signature _____

(To confirm satisfactory demonstration and receipt of manufacturer's literature)

*All installations in England and Wales must be notified to Local Authority Building Control (LABC) either directly or through a Competent Persons Scheme. A Building Regulations Compliance Certificate will then be issued to the customer.



SERVICE INTERVAL RECORD

It is recommended that your heating system is serviced regularly
and that you complete the appropriate Service Interval Record Below .

Service Provider. Before completing the appropriate Service Interval Record below, please ensure you have carried out the service as described in the boiler manufacturer's instructions. Always use the manufacturer's specified spare part when replacing all controls.

SERVICE 1 Date _____

Energy Efficiency Checklist completed? Yes No

Engineer Name _____

Company Name _____

Telephone Number _____

Engineer ID Number _____

Comments _____

Signature _____

SERVICE 2 Date _____

Energy Efficiency Checklist completed? Yes No

Engineer Name _____

Company Name _____

Telephone Number _____

Engineer ID Number _____

Comments _____

Signature _____

SERVICE 3 Date _____

Energy Efficiency Checklist completed? Yes No

Engineer Name _____

Company Name _____

Telephone Number _____

Engineer ID Number _____

Comments _____

Signature _____

SERVICE 4 Date _____

Energy Efficiency Checklist completed? Yes No

Engineer Name _____

Company Name _____

Telephone Number _____

Engineer ID Number _____

Comments _____

Signature _____

SERVICE 5 Date _____

Energy Efficiency Checklist completed? Yes No

Engineer Name _____

Company Name _____

Telephone Number _____

Engineer ID Number _____

Comments _____

Signature _____

SERVICE 6 Date _____

Energy Efficiency Checklist completed? Yes No

Engineer Name _____

Company Name _____

Telephone Number _____

Engineer ID Number _____

Comments _____

Signature _____

SERVICE 7 Date _____

Energy Efficiency Checklist completed? Yes No

Engineer Name _____

Company Name _____

Telephone Number _____

Engineer ID Number _____

Comments _____

Signature _____

SERVICE 8 Date _____

Energy Efficiency Checklist completed? Yes No

Engineer Name _____

Company Name _____

Telephone Number _____

Engineer ID Number _____

Comments _____

Signature _____

SERVICE 9 Date _____

Energy Efficiency Checklist completed? Yes No

Engineer Name _____

Company Name _____

Telephone Number _____

Engineer ID Number _____

Comments _____

Signature _____

SERVICE 10 Date _____

Energy Efficiency Checklist completed? Yes No

Engineer Name _____

Company Name _____

Telephone Number _____

Engineer ID Number _____

Comments _____

Signature _____

Vaillant Ltd
Nottingham Road ■ Belper ■ Derbyshire ■ DE56 1JT
Telephone 0845 602 2922 ■ www.vaillant.co.uk ■ info@vaillant.co.uk

0020020828_07 GBIE 042012 – Subject to alterations