

INSTRUCTIONS FOR INSTALLATION AND SERVICING

TURBOmax Plus 824/2 E, 828/2 E

Wall hung room sealed fan assisted combination boilers

THERMOcompact 615/2 E, 620/2 E, 624/2 E, 628/2 E

Wall hung room sealed fan assisted system boilers

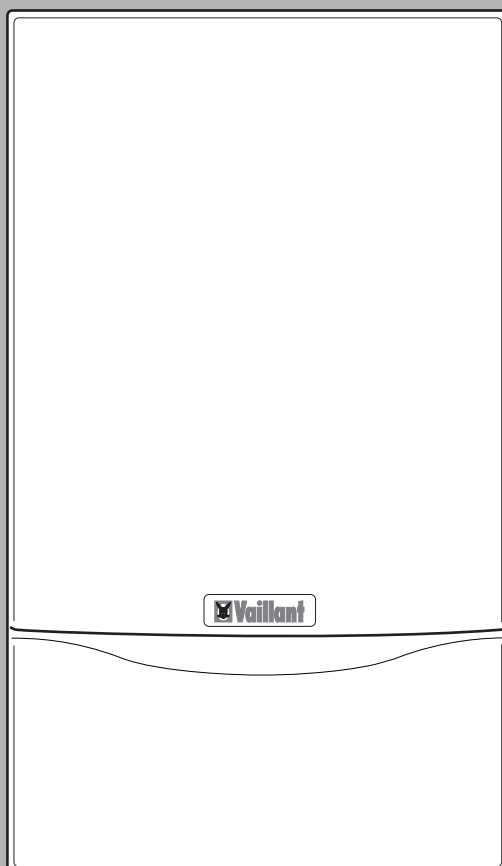

*benchmark*TM

The code of practice for the installation,
commissioning & servicing of central heating systems





TABLE OF CONTENTS



List of Contents

Contents included with boiler (TURBOmax Plus)	4
Contents included with boiler (THERMOcompact)	5



Introduction

General Information	6
General notes	6
EC designation	6



Boiler Specification

Technical data	7
Boiler connections (TURBOmax Plus)	8
Boiler connections (THERMOcompact)	8
Functional diagram (TURBOmax Plus)	9
Functional diagram (THERMOcompact)	10



General Requirements

Related documents	11
Boiler location	12
Gas supply	12
Flue system	13
Top outlet flue system	13
Rear outlet flue system	13
Extended top outlet flue system	13
Flue termination	14
Air supply	15
Cupboard or compartment ventilation	15
Electrical supply	15
Guide to system requirements	16
Water circulation system	16
Filling and make up	16
Pressure relief valve	16
Pressure gauge	16
Expansion vessel	17
Circulating pump	18
System by-pass	18
Venting	18
DHW expansion vessel accessory	18

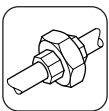

Boiler Installation Sequence

General	19
Preparation of boiler location	19
Selecting position of boiler	19
Using boiler template	20
Fitting the boiler hanging bracket	21
Install the flue system	21
Fitting the boiler	21
Removing boiler casing	22
Gas supply (TURBOmax Plus)	23
Cold water mains inlet and hot water outlet (TURBOmax Plus)	24
Central heating flow and return pipework (TURBOmax Plus)	25
Gas supply (THERMOcompact)	26
Central heating flow and return pipework (THERMOcompact)	27
Connection to a Vantage unvented cylinder (THERMOcompact)	28
Connect the flue system to the boiler	28
Electrical installation general requirements	30
Connection to the main supply	31
Controls	33
Fit boiler casing	38

TURBO
max

THERMO
compact



Commissioning Part I



Gas supply adjustments (Commissioning Part II)



Functional checks (Commissioning Part III)



Servicing

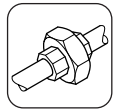

Parts replacement



Fault Finding

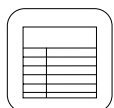

Diagrams



Short parts list

Preliminary electrical checks	39
Gas supply	39
Cold water supply (TURBOmax Plus only)	39
Filling the heating system (TURBOmax Plus)	40
Filling the heating system (THERMOcompact)	42
Initial system flush ('cold')	41/43
Gas inlet working pressure	44
Main burner pressure	45
Adjusting the central heating output (range rating)	46
Adjusting the ignition rate	48
Adjusting to the maximum heat load (nominal load)	49
Burner pressure and gas rate	50/51
Functional checks	52
Functional check of operation	53/54
Adjusting pump speed	55
Final system flush (hot)	55
Handing over to the user	56
Initial inspection	57
Cleaning the burner and primary heat exchanger	58
Safety instructions	59
Initial preparation	59
Burner	60
Electrodes	60
Fan	61
Gas valve	62
Temperature sensors (NTCs)	63
Main heat exchanger	63
Expansion vessel	64
Electronic control board	65
Main transformer	65
Pump	66
Air pressure switch	66
Automatic bypass	67
Pressure gauge	67
Diverter valve (TURBOmax Plus only)	68
Aqua sensor (TURBOmax Plus only)	68
DHW heat exchanger (TURBOmax Plus only)	69
Pressure relief valve	69
Checking functions	70
Introduction	71
Indicator lights	72
Logical fault finding procedure	73
Status mode	74
Diagnostic modes	75
Fault codes	77
Fault memory	77
Fault finding charts	78
Functional flow diagrams	85
Wiring diagrams	87
Short parts list	89

TURBO
max



LIST OF CONTENTS

TURBOmax Plus

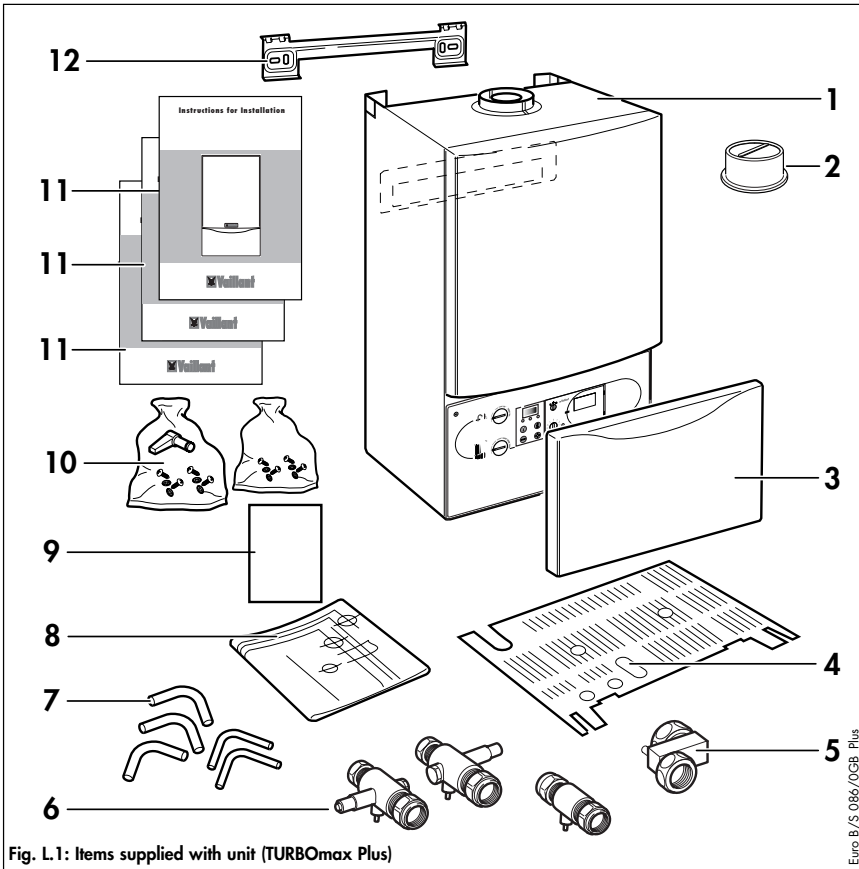

Fig. L.1: Items supplied with unit (TURBOmax Plus)

Euro B/S 086/0GB_Plus

Contents included with boiler (TURBOmax Plus)

Ensure that all contents are included before commencing installation.

DO NOT remove the boiler from the polystyrene base at this stage.

Item	Quantity	Description
1	1	Boiler
2	1	Flue restriction ring
3	1	Controls cover door
4	1	Lower cover plate (packed in bottom packaging)
5	1	Cold water inlet valve
6	3	Flow and return service valve, gas service valve
7	5	Copper tails for gas and water pipework
8	1	Template
9	2	Guarantee Card and Benchmark log book
10	1	Installation and connection accessories and PRV packages incl. DHW outlet union nut
11	3	Installation and Servicing, Users and Flue Installation Instructions
12	1	Hanging bracket

Table L.1: Items supplied with unit (TURBOmax Plus)



Contents included with boiler (THERMOcompact)

Ensure that all contents are included before commencing installation.

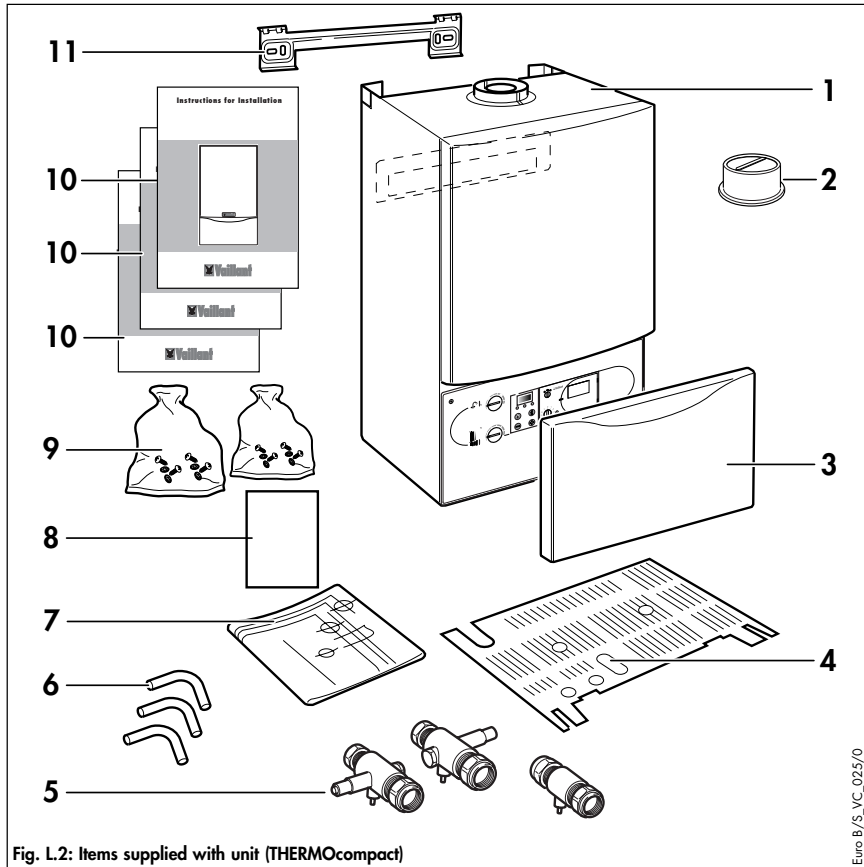

Fig. L.2: Items supplied with unit (THERMOcompact)

Euro B/S_VC_0025/0

DO NOT remove the boiler from the polystyrene base at this stage.

THERMOcompact

Item	Quantity	Description
1	1	Boiler
2	1	Flue restriction ring
3	1	Controls cover door
4	1	Lower cover plate (packed in bottom packaging)
5	3	Flow and return service valve, gas service valve
6	3	Copper tails for gas and water pipework
7	1	Template
8	2	Guarantee Card and Benchmark log book
9	1	Installation and connection accessories and PRV packages
10	3	Installation and Servicing, Users and Flue Installation Instructions
11	1	Hanging bracket

Table L.2: Items supplied with unit (THERMOcompact)



INTRODUCTION

General Information

Note: This boiler must be installed and serviced by a competent person in accordance with the Gas Safety (Installation and Use) Regulations 1998. In the UK „CORGI“ registered installers undertake the work to a safe and satisfactory standard.

TURBOmax Plus boiler

The TURBOmax Plus is a fully automatic, wall mounted, room sealed combination boiler for central heating and domestic hot water. Domestic hot water is supplied directly from the boiler, without requiring a copper cylinder, cold water tank, feed and expansion tank and associated pipework. Domestic hot water has priority over central heating. The TURBOmax Plus range consists of models with outputs for domestic hot water of 24 kW and 28 kW. Both versions are available in natural gas and LPG.

TURBOmax Plus combination boilers incorporate a warmstart facility that keeps the domestic hot water heat exchanger hot, providing an instantaneous delivery of domestic hot water.

The temperature in the domestic hot water heat exchanger is limited by the boiler control system and it is not necessary to install a scale reducer on the cold mains to the boiler. However, in exceptionally hard water areas to prevent scale formation in the property hot water system pipework, a scale reducer may be fitted.

The heating system can be filled using the built-in filling loop contained within the boiler.

THERMOcompact boiler

The THERMOcompact is a fully automatic, wall mounted, room sealed system boiler for central heating and domestic hot water (where a separate indirect hot water storage cylinder is also incorporated in the system).

The THERMOcompact range consists of models with outputs of 15, 20, 24 kW and 28 kW.

All THERMOcompact boilers are available in Natural Gas. The 20 and 28 kW versions are also available in LPG.

General Notes

The boilers have been designed for use with a sealed central heating system, and come fully tested and assembled with a built in circulating pump, expansion vessel and diverter valve (TURBOmax Plus only). The boilers are not suitable for use on open vented systems.

The boilers are easily sited on any internal wall and can be installed with either a horizontal or vertical RSF (room sealed fan assisted) flue. Two types of flue systems are available, the standard concentric flue system (100 mm outside diameter) and a larger diameter concentric flue system (125 mm outside diameter) which allows longer flue lengths to be achieved. Flue extensions and additional bends and elbows are available for both flue systems to increase the siting flexibility. There is also a 100 mm diameter concentric flue accessory which connects to the alternative rear flue outlet on the boiler for direct through the wall installations. The boilers are not suitable for external installation. If desired, an inhibitor may be used in the system. Guidance on the use of inhibitors is contained in these instructions.

All boilers have a built in diagnostic system which indicates the

This feature provides key information to aid commissioning and fault finding.

The data badge is fitted on the rear of the control panel.

See text of General Requirements for installation requirements or notes.

Vaillant Ltd. support the Benchmark initiative.

Within the information pack, you will find a Benchmark Log Book. It is very important that this is completed correctly at the time of installation, commissioning and handover to the user.

EC designation



TURBOmax Plus (824/828) and THERMOcompact boilers (615/620/624/628) carry the "CE" Mark. This demonstrates that the boilers fulfil the essential requirements of the Gas Appliance Directive (90/396/EEC) and the Gas Appliance (Safety) Regulations 1992.

The "CE" Mark also demonstrates that the boilers comply with the requirements of the Electromagnetic Compatibility Directive (89/336/EEC), the Low Voltage Directive (72/23/EEC), the Boiler Efficiency Directive (92/42/EEC) and the Boiler (Efficiency) Regulations 1993.



Technical data

	THERMOcompact 615/2 E (VU GB 152/2-5)	THERMOcompact 620/2 E (VU GB 202/2-5)	THERMOcompact 624/2 E (VU GB 242/2-5) TURBOmax Plus 824/2 E (VUW GB 242/2-5)	THERMOcompact 628/2 E (VU GB 282/2-5) TURBOmax Plus 828/2 E (VUW GB 282/2-5)	Units
Maximum CH heat input (net)	16.5 (56.100)	22.0 (74.800)	26.7 (91200)	31.1 (106200)	kW (Btu/h)
CH heat output range (80/60 °C)	6.5 - 15 (22300 - 51200)	7.7 - 20 (26300 - 68300)	8.9 - 24 (30400 - 81900)	10.4 - 28 (35500 - 95500)	kW (Btu/h)
Maximum DHW heat input (net)	–	–	26.7 (91200)	31.1 (106200)	kW (Btu/h)
DHW heat output	–	–	24	28	kW
DHW flow rate $\Delta T = 35\text{ °C}$ rise	–	–	9.8	11.5	l/min
DHW flow rate at factory set temperature rise ($\Delta T 42\text{ °C}$)	–	–	8.2	9.5	l/min
Mains water pressure required for max. flow rate	–	–	0.5	0.5	bar
Minimum water flow rate	–	–	1.5	1.5	l/min
Mains water pressure required for min. flow rate	–	–	0.15	0.15	bar
Maximum inlet water pressure	–	–	10	10	bar
Inlet gas working pressure required (natural gas)	20	20	20	20	mbar
Gas supply (G20) Gross CV (s.t.)	37.8	37.8	37.8	37.8	MJ/m ³
Gas burner pressure max. rate	10.5	9.6	9.8	10.8	mbar
Gas burner pressure ignition rate	2.3	1.8	1.9	1.8	mbar
Gas rate max. (DHW)	–	–	2.8	3.3	m ³ /h
CH temperature flow range	35 - 82	35 - 82	35 - 82	35 - 82	°C
Minimum CH water flow (for 20 °C rise)	650	860	1032	1203	l/h
Pump pressure available	0.25 (25)	0.25 (25)	0.25 (25)	0.25 (25)	bar (KPa)
Expansion vessel pre-charge pressure	0.75	0.75	0.75	0.75	bar
Maximum CH system pressure	3	3	3	3	bar
Weight	38	39	41/43	43/45	kg
Primary water content	2.0	2.0	2.0	2.0	l
Electrical supply	230/50	230/50	230/50	230/50	V~/Hz
External fuse	3	3	3	3	A
Power input	150	150	150	150	W
Case height	800	800	800	800	mm
Case width	440	440	440	440	mm
Case depth	338	338	338	338	mm



BOILER SPECIFICATION

TURBOmax Plus

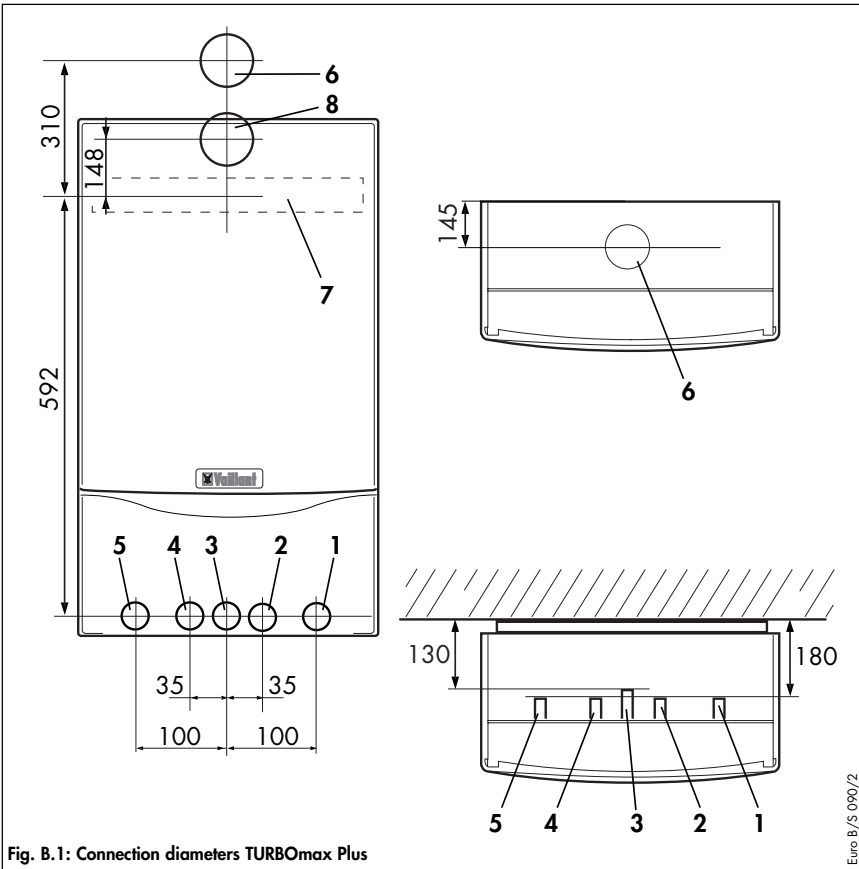

Fig. B.1: Connection diameters TURBOmax Plus

Euro B/S_090/2

Boiler connections (TURBOmax Plus)

Key:

- 1 Heating system return (22 mm tail)
- 2 Cold water connection with shut off valve (15 mm tail)
- 3 Gas connection (15 mm tail)
- 4 Hot water connection (15 mm tail)
- 5 Heating system flow (22 mm tail)
- 6 Flue outlet (100 mm flue with turret)
- 7 Hanging bracket
- 8 Rear flue outlet

THERMOcompact

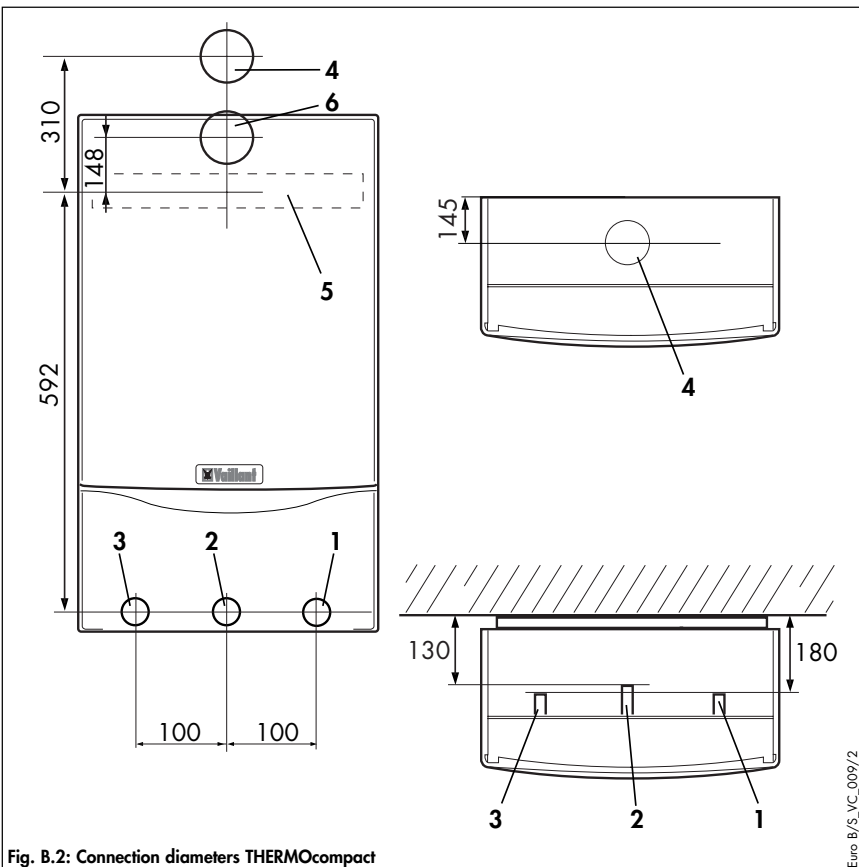

Fig. B.2: Connection diameters THERMOcompact

Euro B/S_VC_009/2

Boiler connections (THERMOcompact)

Key:

- 1 Heating system return (22 mm tail)
- 2 Gas connection (15 mm tail)
- 3 Heating system flow (22 mm tail)
- 4 Flue outlet (100 mm flue with turret)
- 5 Hanging bracket
- 6 Rear flue outlet

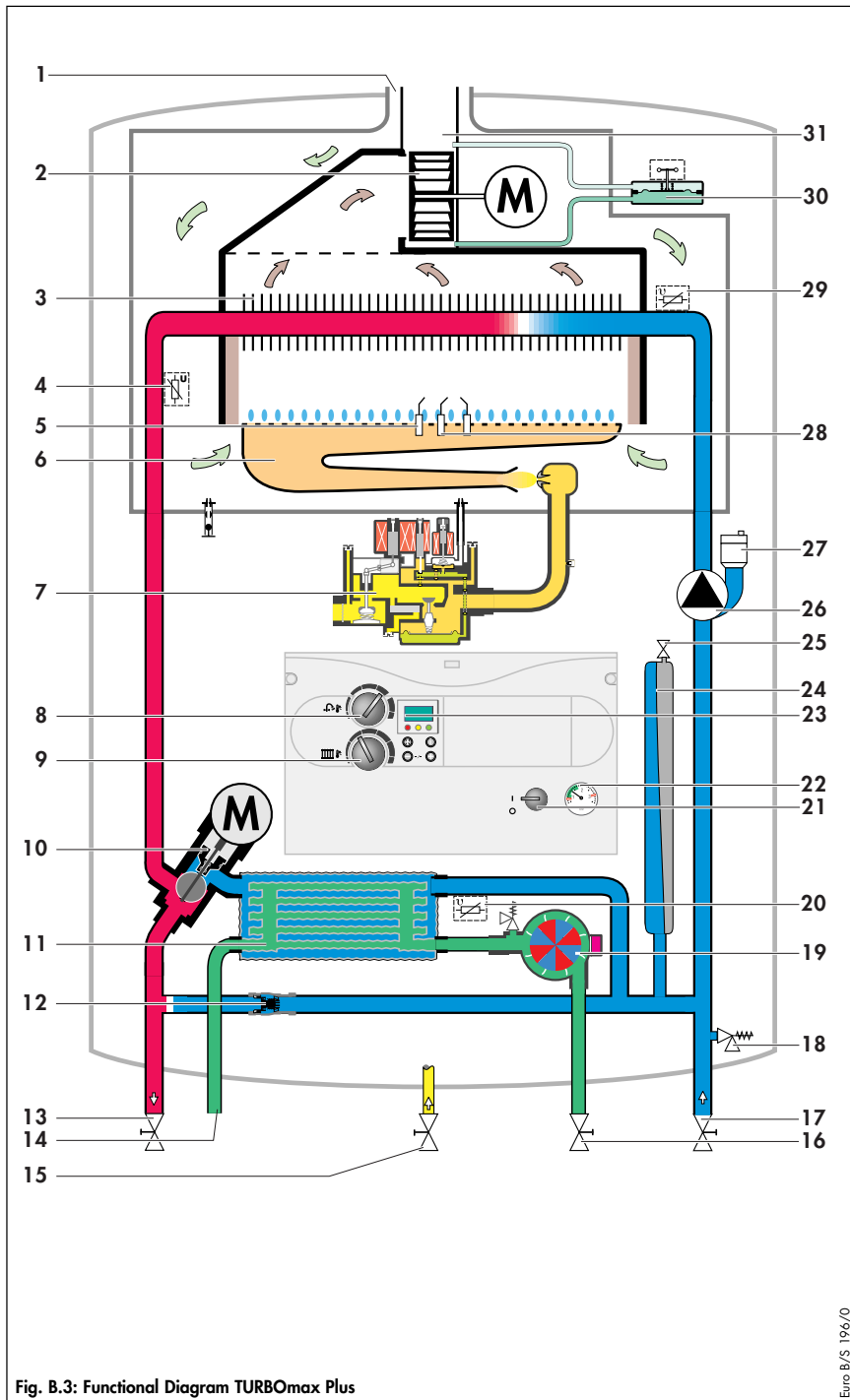

Functional Diagram (TURBOmax Plus)

- 1 Air duct
- 2 Fan
- 3 Main heat exchanger
- 4 Temperature sensor (NTC I)
- 5 Flame sensing electrodes
- 6 Modulating burner
- 7 Fully modulating automatic gas valve
- 8 Maximum hot water temperature control
- 9 Maximum radiator temperature control
- 10 Diverter valve
- 11 DHW heat exchanger
- 12 Automatic bypass valve
- 13 CH flow service valve
- 14 Hot water outlet
- 15 Gas service valve
- 16 Cold water service valve
- 17 CH return service valve
- 18 Pressure relief valve
- 19 Aqua sensor (DHW flow switch)
- 20 Temperature sensor (NTC III)
- 21 Main on/off control
- 22 Pressure gauge
- 23 Display
- 24 Expansion vessel
- 25 Expansion vessel charging valve
- 26 Circulating pump
- 27 Automatic air vent
- 28 Ignition electrode
- 29 Temperature sensor (NTC II)
- 30 Air pressure switch
- 31 Flue gas duct

Fig. B.3: Functional Diagram TURBOmax Plus

Euro B/S 19%/0



BOILER SPECIFICATION

THERMOcompact

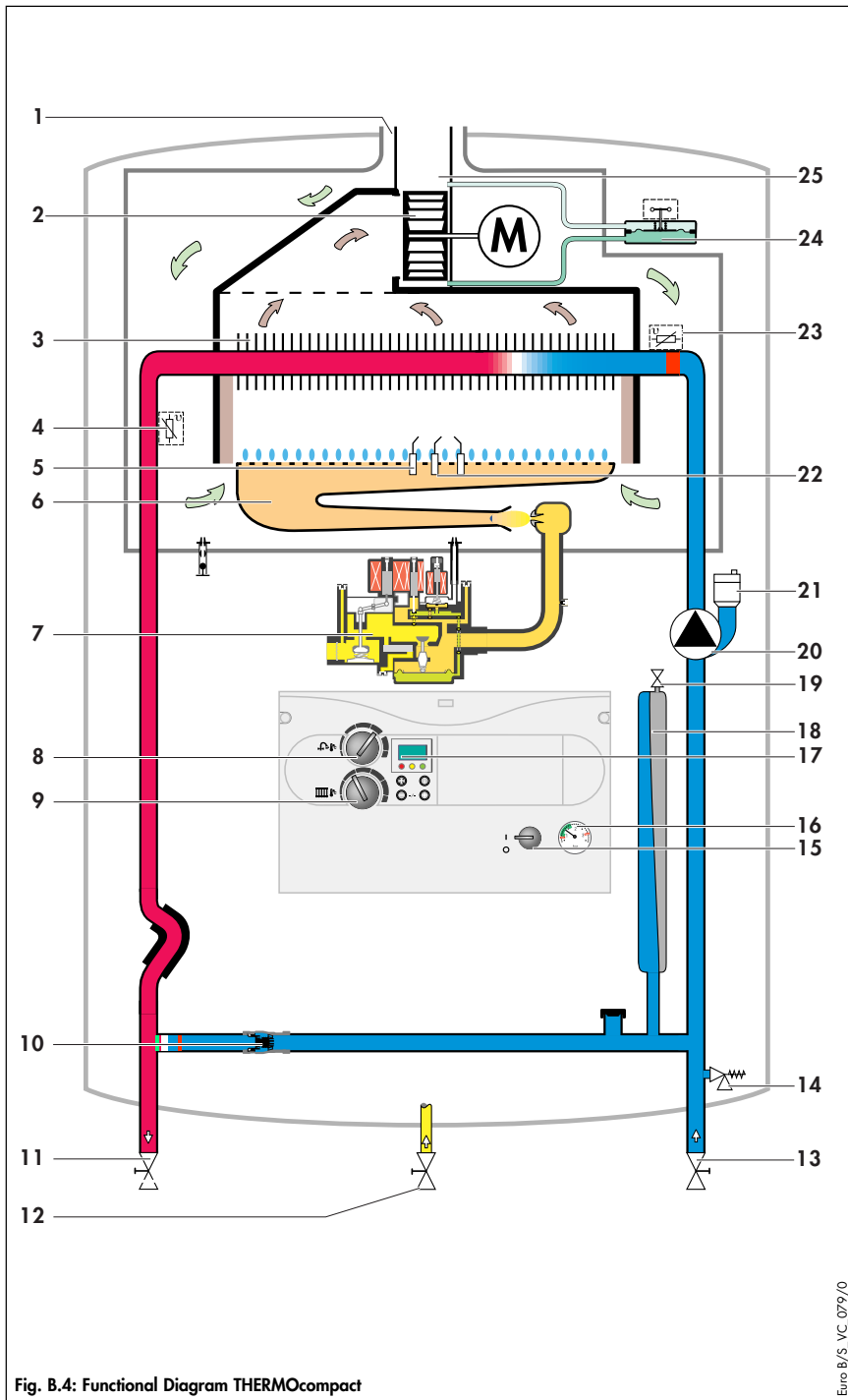

Functional Diagram (THERMOcompact)

- 1 Air duct
- 2 Fan
- 3 Main heat exchanger
- 4 Temperature sensor (NTC I)
- 5 Flame sensing electrodes
- 6 Modulating burner
- 7 Fully modulating automatic gas valve
- 8 This control has no function on this boiler
- 9 Maximum radiator temperature control
- 10 Automatic bypass valve
- 11 CH flow service valve
- 12 Gas service valve
- 13 CH return service valve
- 14 Pressure relief valve
- 15 Main on/off control
- 16 Pressure gauge
- 17 Display
- 18 Expansion vessel
- 19 Expansion vessel charging valve
- 20 Circulating pump
- 21 Automatic air vent
- 22 Ignition electrode
- 23 Temperature sensor (NTC II)
- 24 Air pressure switch
- 25 Flue gas duct

Fig. B.4: Functional Diagram THERMOcompact

Euro B/S_VC_079/0

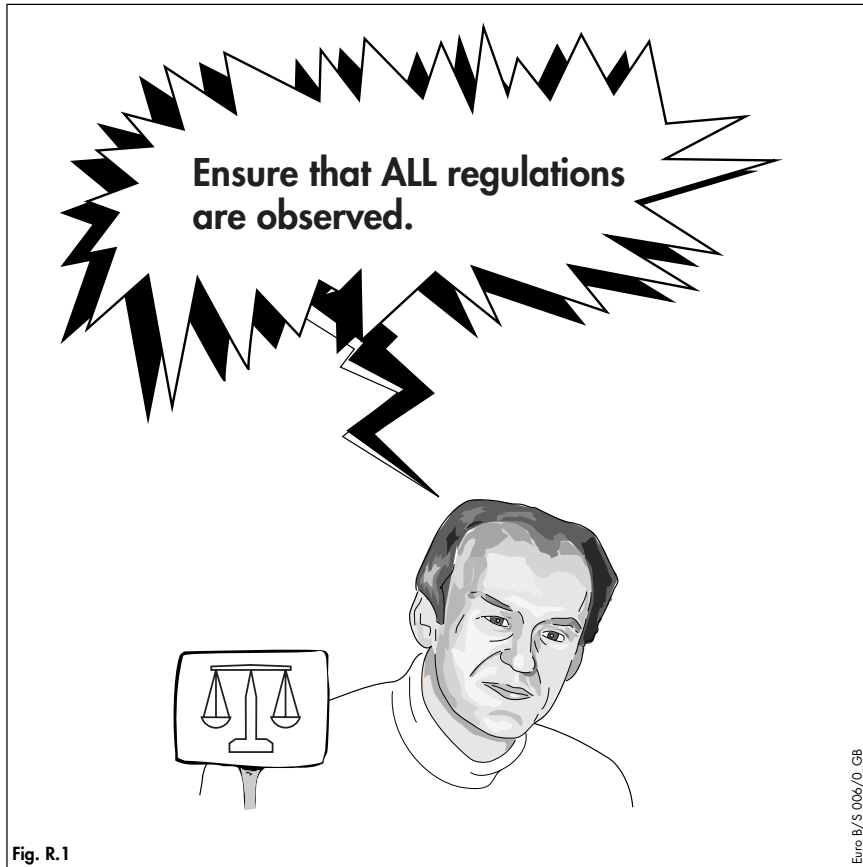

Fig. R.1

Related Documents

The installation of the boiler must be in accordance with the relevant requirements of Gas Safety (Installation and Use) Regulations 1998, Health and Safety Document No. 635 (The Electricity at Work Regulations 1989), BS7671 (IEE Wiring Regulations) and the Water Supply (Water Fittings) Regulations. It should also be in accordance with the relevant requirements of the Local Authority, Building Regulations, Building Standards (Scotland) Regulations and the relevant recommendations of the following British Standards:

BS 5440: Flues and ventilation of gas fired boilers not exceeding 70 kW net:

- Part 1: Flues
- Part 2: Ventilation

BS 5449: Specification for forced circulation hot water for domestic premises.

BS 5546: Specification for gas hot water supplies for domestic premises.

BS 6700: Services supplying water for domestic use within buildings and their curtilages.

BS 6798: Specification for installation of gas fired boilers not exceeding 60 kW input.

BS 6891: Specification for installation of low pressure gas pipework up to 28 mm (R1) in domestic premises (2nd family gas).

BS 7593: Treatment of water in domestic hot water central heating systems.
Institute of Gas Engineers Publication IGE/UP/7/1998: Guide for Installation in Timber Framed Housing.

Important: The appliance must be installed and serviced by a competent person as stated in the Gas Safety (Installation and Use) Regulations 1998.

Preliminary remarks

This appliance should only be installed in conjunction with a Vaillant flue system.

Install the flue system as detailed in the separate flue installation instructions supplied with this boiler.



GENERAL REQUIREMENTS

Boiler location

The location chosen for the boiler must permit the provision of a satisfactory flue termination. The location must also provide adequate space for servicing and air circulation around the boiler. The boiler may be installed in any room, although particular attention is drawn to the requirements of BS7671 (IEE Regulations) and, in Scotland, the electrical provisions of the Building Standards (Scotland) Regulations, in respect of the installation of a boiler in a room containing a bath or shower.

Note: Where a room sealed boiler is installed in a room containing a bath or shower, any electrical switch or boiler control utilising mains electricity should be so situated that it cannot be touched by a person using the bath or shower.

Where the installation of the boiler will be in an unusual location, special procedures may be necessary and BS 5546 and BS 6798 give detailed guidance on this aspect. The boiler must be mounted on a flat, vertical wall, which must be sufficiently robust to take the weight of the boiler. The boiler may be installed on a combustible wall, subject to the requirements of the Local Authorities and Building Regulations.

A compartment used to enclose the boiler must be designed and constructed specifically for this purpose. (An existing cupboard or compartment may be used provided that it is modified for the purpose). Details of essential features of cupboard/compartment design including airing cupboard installations are given in BS 6798. If the boiler is to be fitted in a timber framed building, it should be fitted in accordance with Institute of Gas Engineers Publication IGE/UP/7/1998 „Guide for Gas Installation in Timber Framed Housing“.

Gas Supply

The gas supplier should ensure the availability of an adequate supply of gas.

A gas meter may only be connected to the service pipe by the supplier of gas or their contractor.

An existing meter should be checked to ensure that it is capable of passing the rate of gas supply required.

Installation pipes should be fitted in accordance with BS 6891.

Pipework from the meter to the boiler must be of an adequate size. Do not use pipes of a smaller size than the boiler gas connection (15 mm).

The complete installation must be tested for soundness and purged as described in BS 6891.

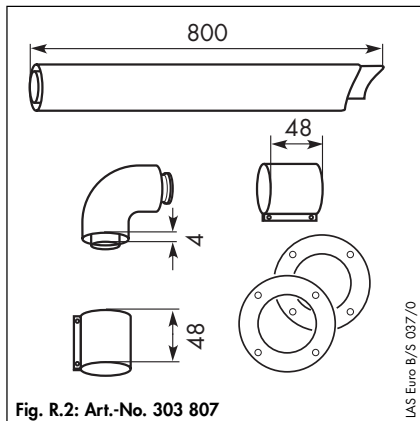

Fig. R.2: Art.-No. 303 807

IAS Euro B/S 037/0

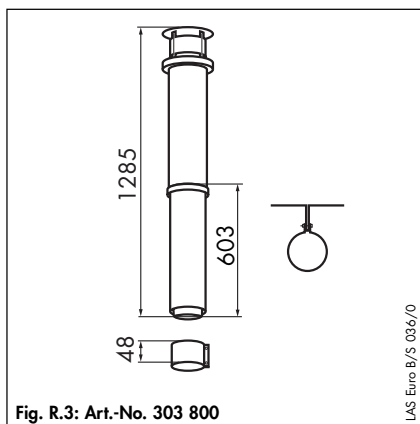

Fig. R.3: Art.-No. 303 800

IAS Euro B/S 036/0

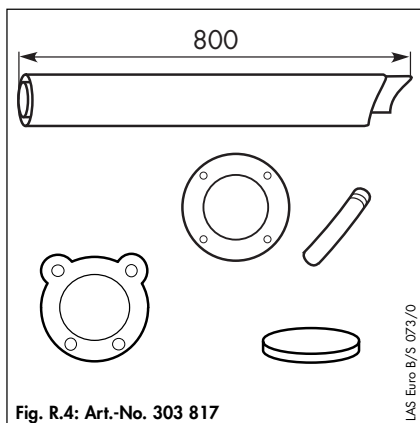

Fig. R.4: Art.-No. 303 817

IAS Euro B/S 073/0

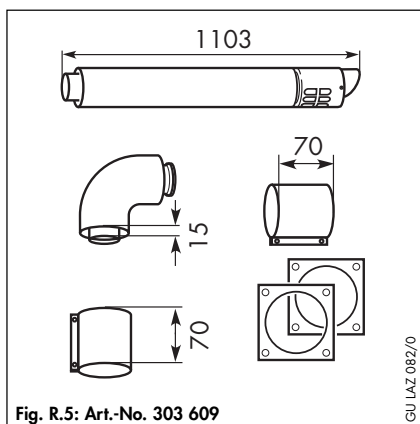

Fig. R.5: Art.-No. 303 609

GU LAZ 082/0

Flue system

Note: The boilers are delivered ready for installation utilising a top outlet flue assembly. For installation with a rear outlet flue assembly refer to the boiler flue outlet adaptation instructions supplied with the rear flue accessory.

Top outlet flue system (100 mm outside diameter)

The top outlet horizontal flue system (Art. No. 303 807) is suitable for installations up to 720 mm measured from the centre of the boiler flue outlet to the outside face of the wall. Flue extensions are available to extend this length up to 5.3 m for 15/20 kW; 4.5 m for 24 kW and 3.2 m for 28 kW. Both 90° bends and 45° elbows are also available to increase siting flexibility.

A vertical flue system is also available (Art. No. 303 800).

Refer to flue system installation instructions for full details.

Rear outlet flue system (100 mm outside diameter)

The rear outlet horizontal flue system (Art. No. 303 817) is suitable for installations up to 600 mm wall thickness.

Extended top outlet flue system (125 mm outside diameter)

A top outlet horizontal flue system of 125 mm outside diameter is also available (Art. No. 303 609) and can be used to achieve flue lengths of up to 12.9 m for 15/20/24 kW; 10 m for 28 kW. Both 45° and 90° bends and elbows are also available to increase siting flexibility.

A vertical 125 mm concentric flue system is also available (Art. No. 303 600).

Refer to flue system installation instructions for full details.



GENERAL REQUIREMENTS

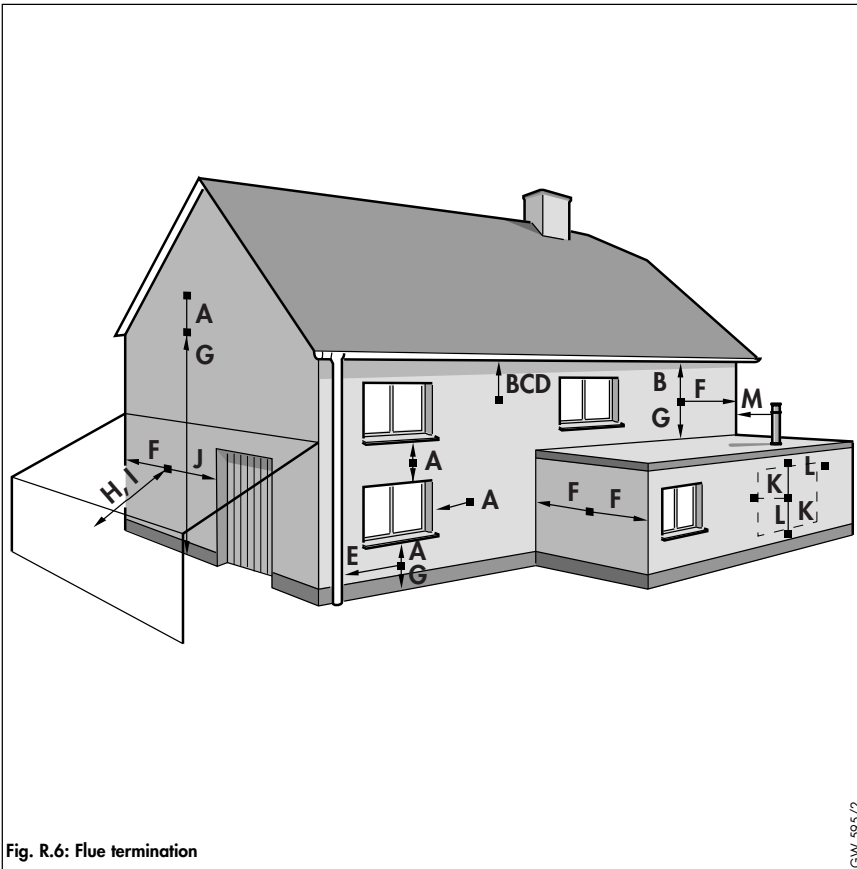

Fig. R.6: Flue termination

GW 993/2

Flue termination

The following details refer to both flue systems.

- a. The terminal must be positioned such that the products of combustion can disperse freely at all times.
- b. In certain weather conditions a plume of water vapour may be visible from the flue terminal. Positions where this could be a nuisance should be avoided.
- c. If the terminal is fitted less than 2 m above a balcony, above ground or above a flat roof to which people have access then a suitable terminal guard; 280 mm x 280 mm x 270 mm deep, must be provided and fitted (made by Tower Flue Components, Tonbridge, TN9 1TB).

Note: Vertical flues must not terminate within 600 mm of an openable window, air vent or any other ventilation opening.

Where a terminal is fitted less than 1 m below a plastic gutter or less than 0.5 m below painted eaves or any other painted surface then a suitable shield at least 1 m long should be fitted to protect the surface.

	Terminal position for fan-assisted flue (minimum distance)	mm
A ¹⁾	Directly below an openable, above an opening or horizontal to an opening i.e. air brick, opening window or other, etc	300
B	Below gutters, soil pipes or drain pipes	25
C	Below eaves	25
D	Below balconies (below car port roof)	25
E	From vertical drain pipes and soil pipes	25
F	From internal or external corners	25
G	Above ground or balcony level	300
H	From a surface or boundary facing a terminal	600*
I	From a terminal facing a terminal	1200
J	From an opening in a car port (e.g. door, window) into a dwelling	1200
K	Vertically from a terminal on the same wall	1500
L	Horizontally from a terminal on the same wall	300
M	Distance from adjacent wall for vertical Flue	500

¹⁾ In addition, the terminal should not be nearer than 150 mm to an opening in the building fabric formed for the purpose of accommodating a built-in element such as a window.

* BS 5440-1 It is recommended that a fanned flue terminal should be positioned as follows: a) at least 2 m from an opening in a building directly opposite, and b) so that the products of combustion are not directly directed to discharge across a boundary.



Air supply

Detailed recommendations for air supply are given in BS 5440: Part 2.

It is not necessary to have an air vent in the room or internal space in which the boiler is installed.

Cupboard or compartment ventilation

The boilers are very high efficiency appliances. As a consequence the heat loss from the appliance casing during operation is very low. For cupboard or compartment installations it is therefore not necessary to provide any high or low level permanent air vents for cooling purposes.

Electrical supply

A 230 V, ~ 50 Hz single phase electricity supply fused to 3 Amp. must be provided in accordance with the latest edition of BS7671 (IEE Wiring Regulations) and any other local regulations that may apply.

The method of connection to the mains electricity supply must provide a means of completely isolating the boiler and its ancillary controls. Isolation is preferably by the use of a fused three pin plug and unswitched shuttered socket outlet, both complying with the requirements of BS 1363. Alternatively, a 3 Amp. fused doublepole switch with a 3 mm contact separation on both poles may be used.

This appliance must be earthed.



GENERAL REQUIREMENTS

Guide to system requirements

Water circulation system

Detailed recommendations for the water circulation system are given in BS 6798 and BS 5449: Part 1 (for small bore and micro bore central heating systems).

Pipework not forming part of the useful heating surface should be insulated to help prevent heat loss and possible freezing, particularly where pipes are run through roof spaces and ventilated underfloor spaces.

Draining taps must be located in accessible positions which permit the draining of the whole system including the boiler and the hot water system. Draining taps should be at least 1/2 in. BSP nominal size and be in accordance with BS 2879.

The boiler is suitable for use with minibore or microbore systems. Copper tubing to BS 2871: Part 1 should be used for water carrying pipework. All capillary joints in all DHW pipework must be made with lead free solder.

Particularly where a new boiler is to be fitted to an existing system, it is good practice that the system is thoroughly cleansed. This cleansing should take place prior to the fitting of the new boiler and be in accordance with BS 7593.

For advice on the application of system cleansers contact either Sentinel, Betz Dearborn Ltd. Widnes, Cheshire, WA8 8UD.
Tel: 0151 495 1861
or:
Fernox
Alpha-Fry Technologies
Tandem House
Marlow Way, Beddington Farm Road
Croydon CR0 4xS
Tel. 0870 601 5000
Fernox technical
help line 01799 550811

Filling and make up

The system can be filled using the built in filling loop (TURBOmax Plus only) or via a separate filling point fitted at a convenient position on the heating circuit (THERMOcompact). The connection must be removed when filling is completed. Where local Water Authority regulation does not allow temporary connection, a sealed system filler pump with break tank must be used. The heating system will not be filled automatically from the domestic hot water side.

(Alternative methods of filling sealed systems are given in BS 5449).

Pressure relief valve

A pressure relief valve is provided with the boiler. This safety device is required on all sealed C.H. systems and is preset at 3 bar and provided with a 15 mm compression connection for a discharge pipe, which must be of no less than 15 mm in diameter. The Pressure Relief Valve must not be used for draining purposes.

Pressure gauge

This is factory fitted to the boiler and indicates the primary circuit pressure to facilitate filling and testing.



	Vessel Volume [L]	
Initial system pressure (bar)	1.0	1.5
Pressure relief valve setting (bar)	3.0	
Total water content of system litres		
25	2.7	3.9
50	5.4	7.8
100	10.9	15.6
125	13.6	19.5
150	16.3	23.4
175	19.1	27.3
200	21.8	31.2
225	24.5	35.1
250	27.2	39.0
275	30.0	42.9
300	32.7	46.8
325	35.7	50.7
350	38.1	54.6
375	40.9	58.5
400	43.6	62.4
425	46.3	66.3
450	49.0	70.2
475	51.8	74.1
500	54.5	78.0
For system volumes other than those given above, multiply the system volume by the factor across	0.109	0.156

Table R.2: Sizing of additional expansion vessel

Expansion vessel

The 15 and 20 kW THERMOcompact boilers as well as the 24 kW TURBOmax Plus boiler incorporate a 6 litre expansion vessel which is suitable for a sealed heating system with a maximum water content of 60 litres. A 10 litre expansion vessel kit is available as an optional accessory for for the TURBOmax Plus 24 kW boiler and the 15 and 20 kW THERMOcompact boilers.

The 28 kW TURBOmax Plus and 24, 28 kW THERMOcompact boilers incorporate a 10 litre expansion vessel which is suitable for a sealed heating system with a maximum water content of 100 litres.

If the nominal capacity of the built in expansion vessel is not sufficient for the heating system (for instance in case of modernization of old open systems) an additional expansion vessel can be installed external to the boiler. It should be fitted in the return pipe as close as possible to the boiler in accordance with BS 5449: Part 1.

Guidance on the sizing of an additional expansion vessel is given in Table R.2.



GENERAL REQUIREMENTS

Pump specifications

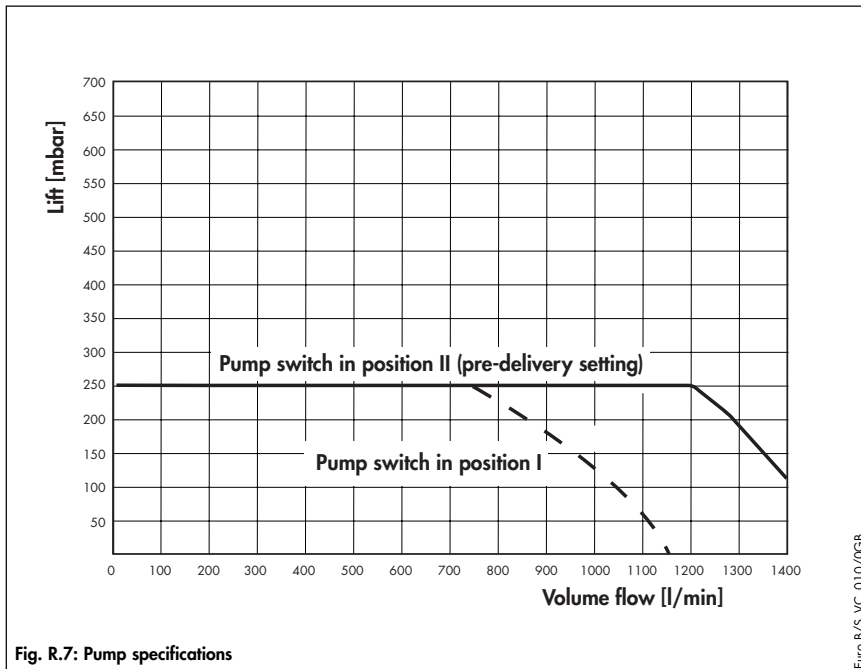

Circulating pump

The circulating pump is included in the boiler. The pump head available for the heating system is shown in fig. R.7.

System by-pass

An automatic system by-pass is included within the boiler. The boiler is suitable for use in systems with thermostatic radiator valves and no additional by-pass is required.

Venting

The boiler is fitted with an automatic air vent. Additional provision should be made to enable the heating system to be vented during filling and commissioning either by automatic air vents or manually.

DHW expansion vessel accessory (TURBOmax Plus only)

A DHW expansion vessel kit (Art. No. 306 237) is available as an optional extra from Vaillant Ltd. This expansion vessel kit should be fitted to the boiler whenever, either a stop valve of the loose jumper type or a non return valve are present in the cold water mains supply to the boiler.

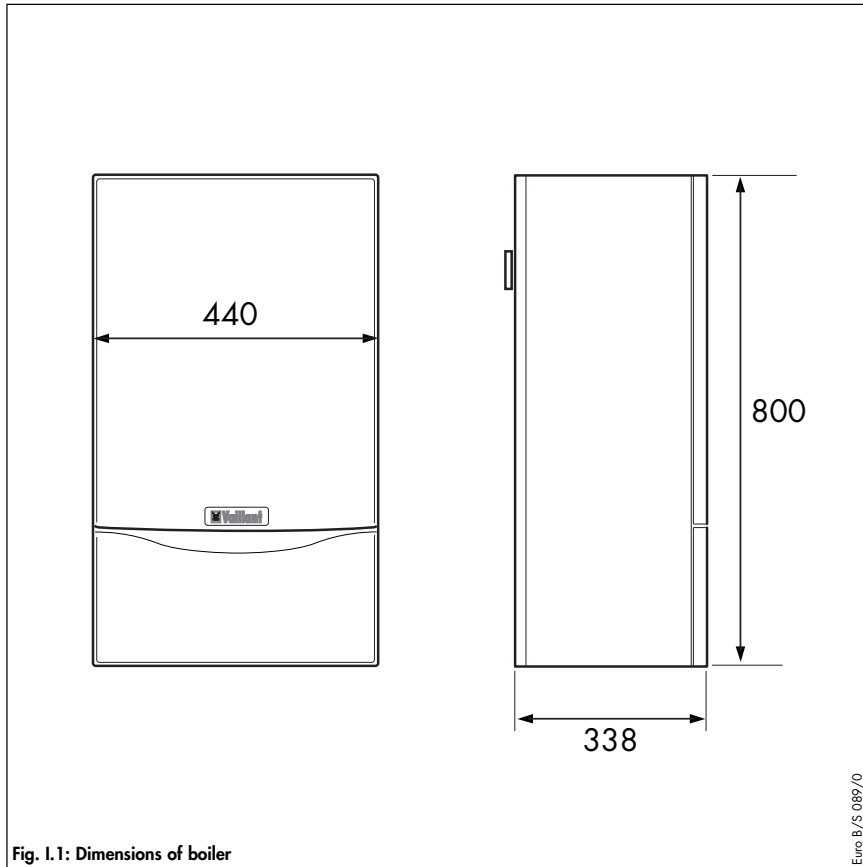
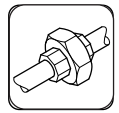

Fig. I.1: Dimensions of boiler

Euro B/S 0897/0

General

Preparation of boiler location

Clearances required

Mount the boiler on a flat and vertical area of wall of sufficient area for the boiler plus the required clearances for installation and servicing.

The clearances are as detailed below and are shown on the installation template supplied with the boiler:

- 150 mm below the boiler
- 5 mm on either side of the boiler
- 210 mm on top of the boiler
- 500 mm in front of the boiler*

* Clearance is only required to enable easier access to the boiler for servicing and may be provided by an openable door, etc.

Note: If the boiler is to be fitted in a timber framed building, it should be fitted in accordance with Institute of Gas Engineers Publication IGE/UP/7/1998 „Guide for Gas Installations in Timber Framed Dwellings“.

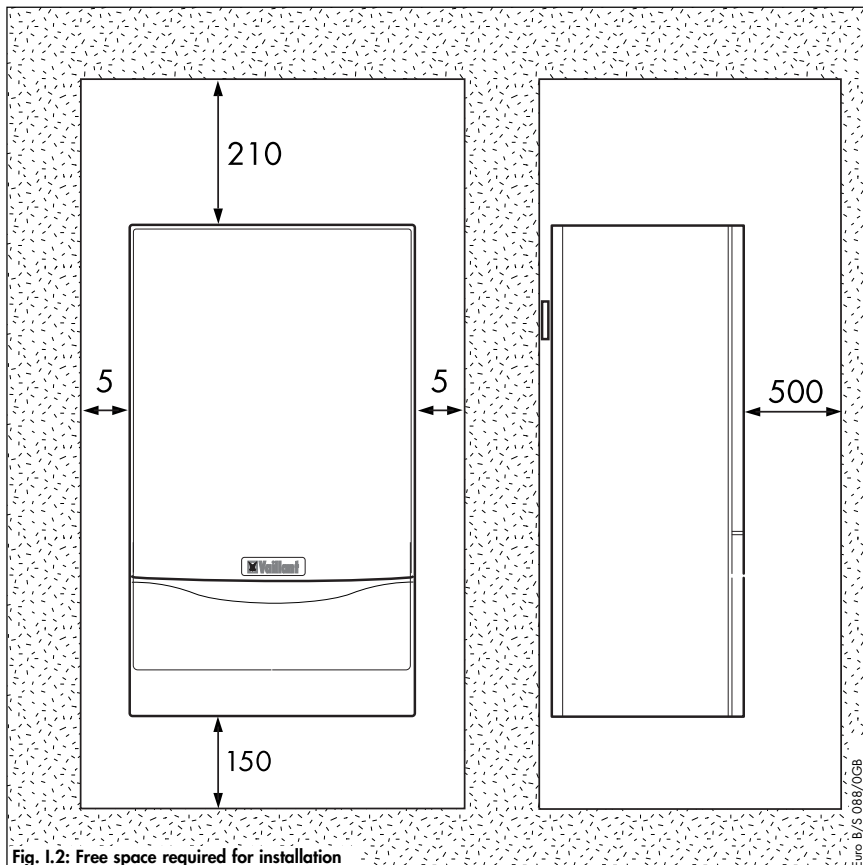

Fig. I.2: Free space required for installation

Euro B/S 0887/0GB

Selecting position of boiler

Refer to „Boiler location“ for information regarding siting the appliance. In general the boiler must be positioned such that:

- There is adequate space around the boiler for service and maintenance.
- The boiler can be correctly flued, i.e. the flue terminal position is sited in accordance with the flue termination section (see page 14) and the air/flue duct can be installed in accordance with the flue installation instructions supplied.
- All necessary pipework can be connected, including the pressure relief valve.

Note: Should it be necessary to run system pipework to above the boiler within the width of the casing, use the optional top connection accessory (Art.No. 306 251).

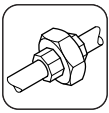

BOILER INSTALLATION SEQUENCE

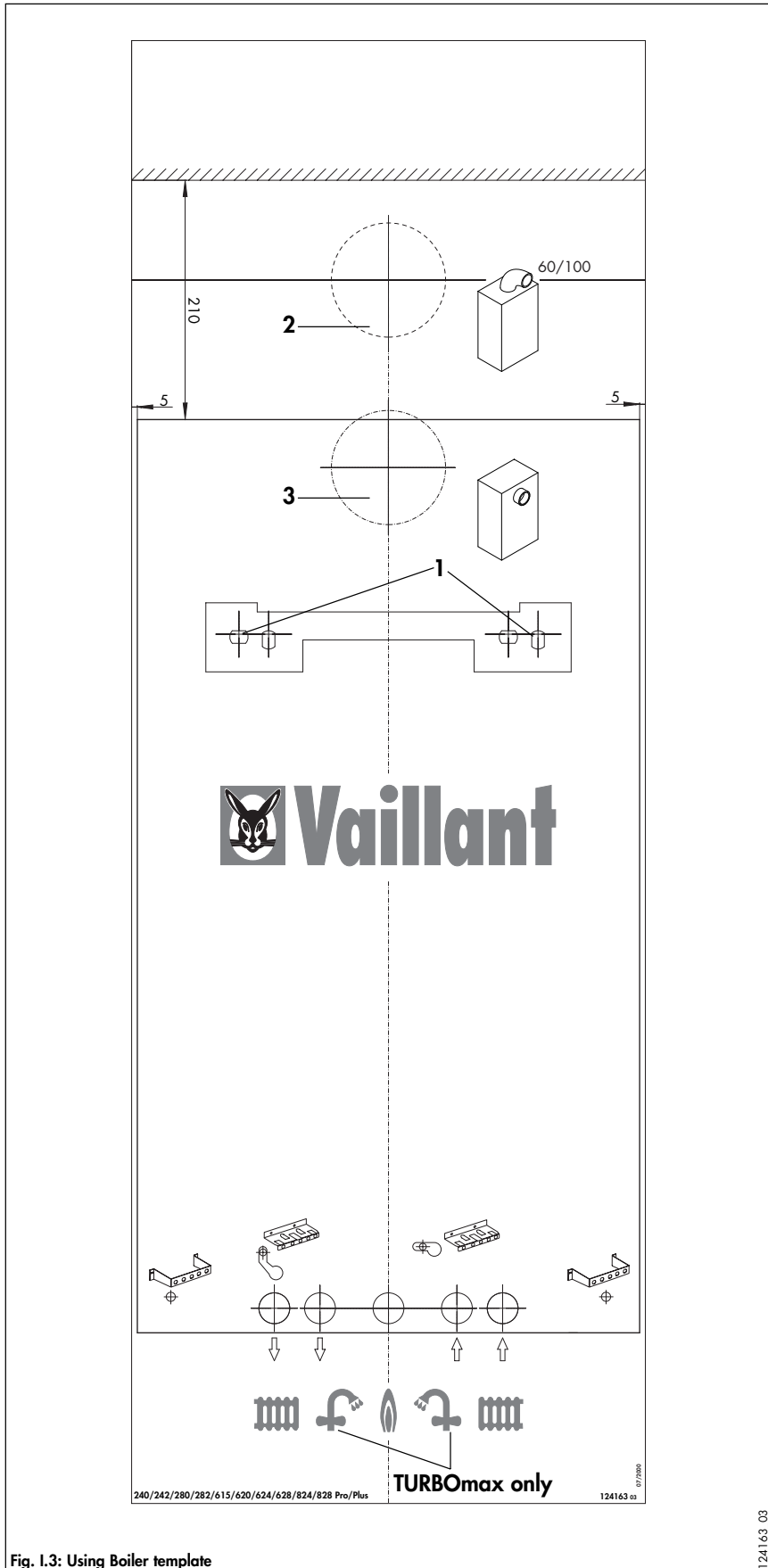

Fig. I.3: Using Boiler template

Using boiler template

Fix the paper template to the wall ensuring that the correct flue exit point has been identified, ensure that the template is vertical.

The template shows

- The position of the fixing holes for the boiler mounting bracket (1).
- The position of the connections.
- The position of the flue exit hole.
- Upper hole (2) indicates top outlet flue with flue turret facing rearward.
- Lower hole (3) indicates rear outlet flue exiting directly through wall.

Mark the position of the hanging bracket fixing holes (1).

Drill 2 holes \varnothing 8 mm for the hanging bracket.

Note: Use alternative fixing holes where necessary.

Identify correct flue exit.

Mark the centre of the selected air/flue duct and its circumference, e.g. by drilling through the template. For installation of a rear exit outlet please refer to the installation instructions of the rear exit outlet kit (Art. No. 303 817).

Other flue options

Flue instructions for other flue systems such as vertical RSF flues, flues run to the side of the boiler and the use of additional bends etc. are detailed in the flue installation instructions provided with the boiler.

Remove the template from the wall and plug the drilled holes using the wallplugs supplied.

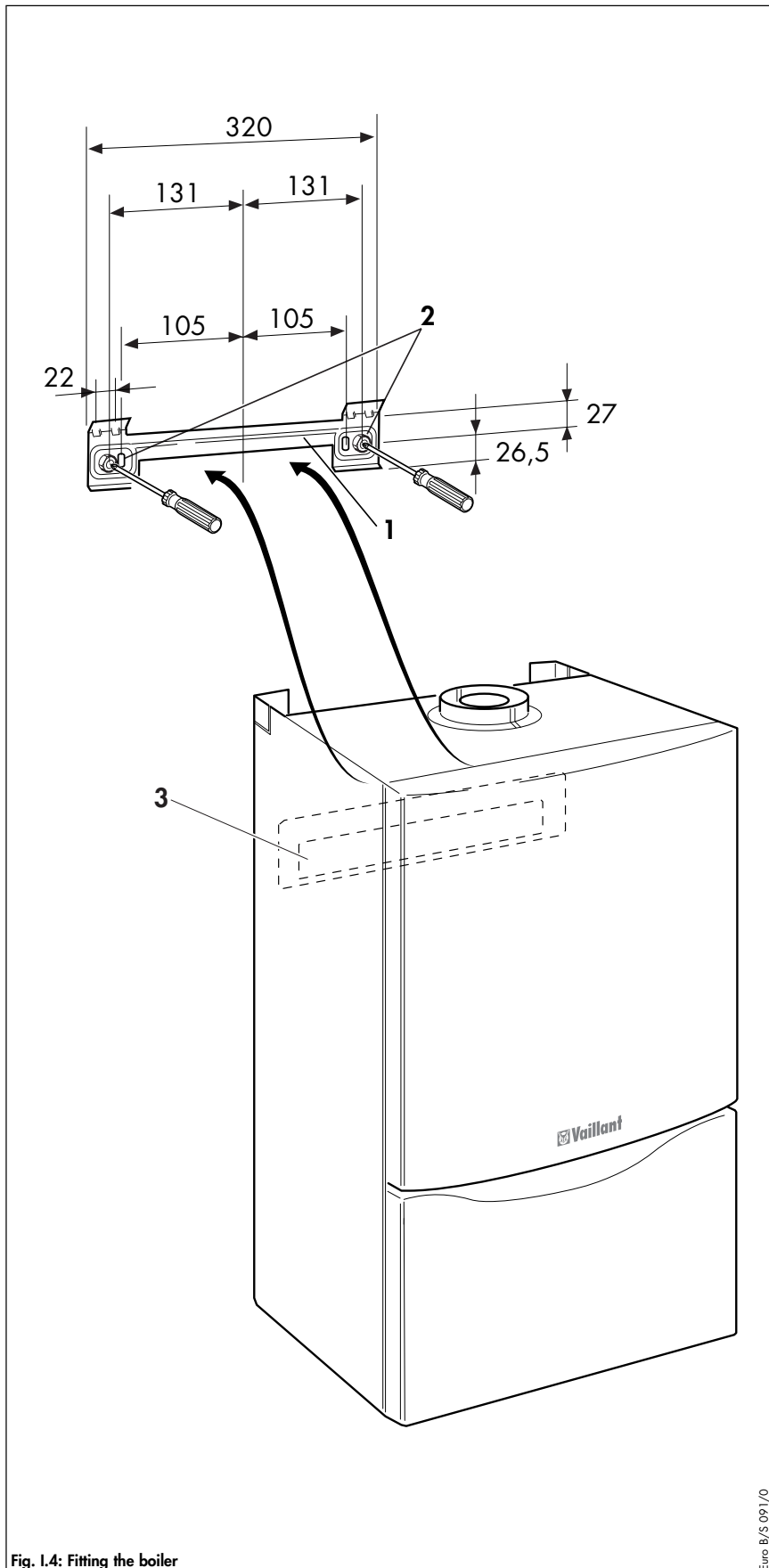
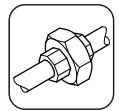

Fig. I.4: Fitting the boiler

Fitting the boiler hanging bracket

Fix the hanging bracket (2) to the wall using the screws supplied. (it may be necessary to use additional or alternative fixings to ensure adequate support).

Note: If the boiler is to be fitted in a timber framed building ensure that the bracket is secured to a substantial part of the timber frame capable of taking the weight of the boiler.

Install the flue system

Install the flue system (refer to separate air/flue duct installation instructions).

Fitting the boiler

- Lift the boiler (3) up to the wall so that it is slightly above the hanging bracket (1).

Note: Lift the boiler from either side at the bottom edge.

- Lower the boiler slowly onto the hanging bracket so that the cross member at the rear of the boiler fully engages onto the hanging bracket.

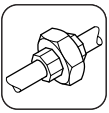

BOILER INSTALLATION SEQUENCE

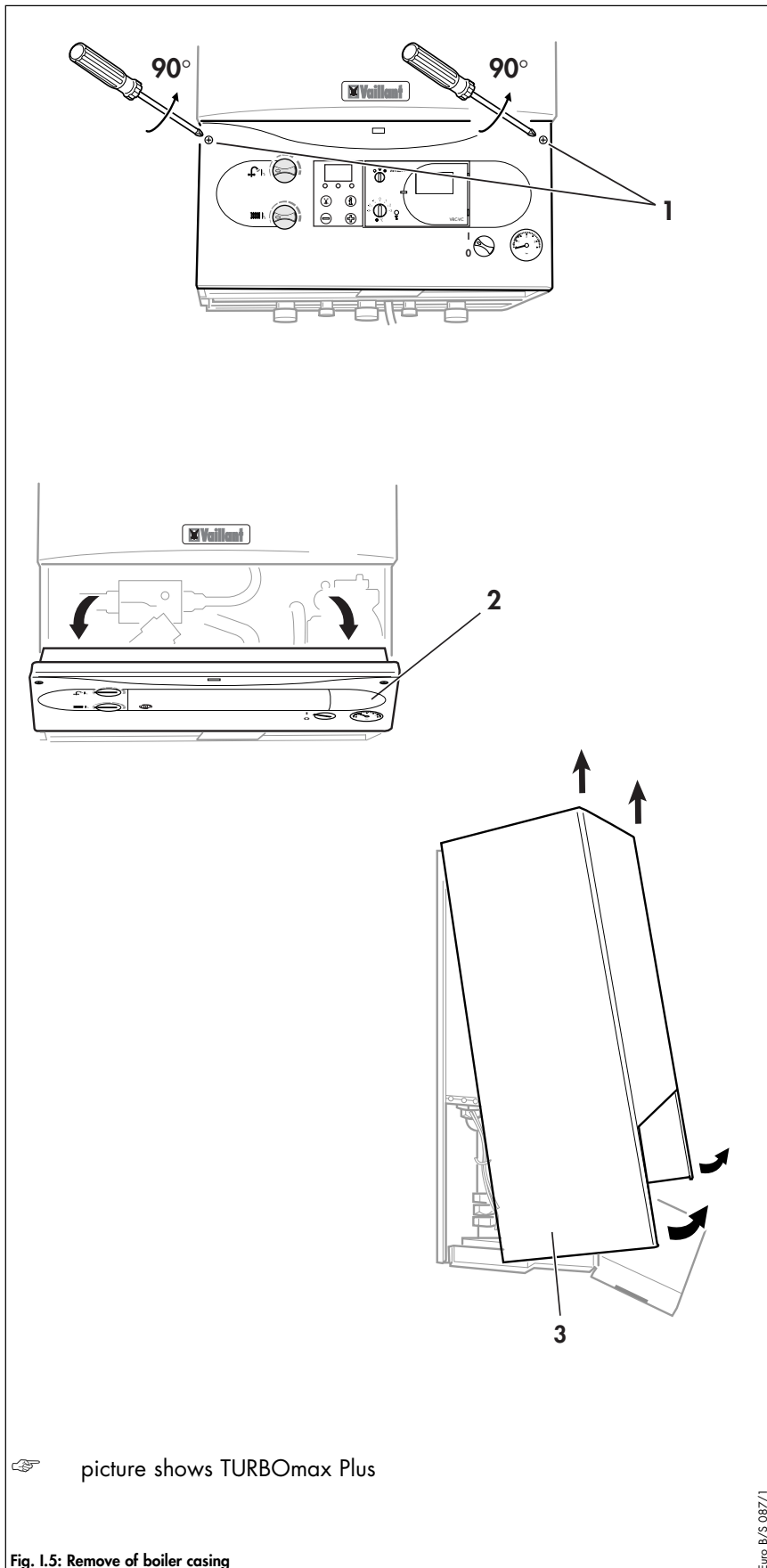

Removing boiler casing

- Turn both securing fasteners (1) anti-clockwise by 90° to release control panel (2).
- Pull the case (3) forward at the bottom to disengage from the securing clips.
- Lift the case slightly to clear the top locations and pull forward to remove.

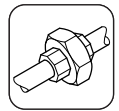

Gas supply (TURBOmax Plus)

- Connect the 15 mm compression gas service cock (1) and 15 mm copper outlet tail (3) as supplied with the appliance (2) and tighten.
- Connect a gas supply pipe of not less than 15 mm diameter to the copper tail.
- Tighten all connections.
(Ensure the gas supply pipework is adequately sized such that a 20 mbar gas pressure is available at the boiler inlet at full flow rate).

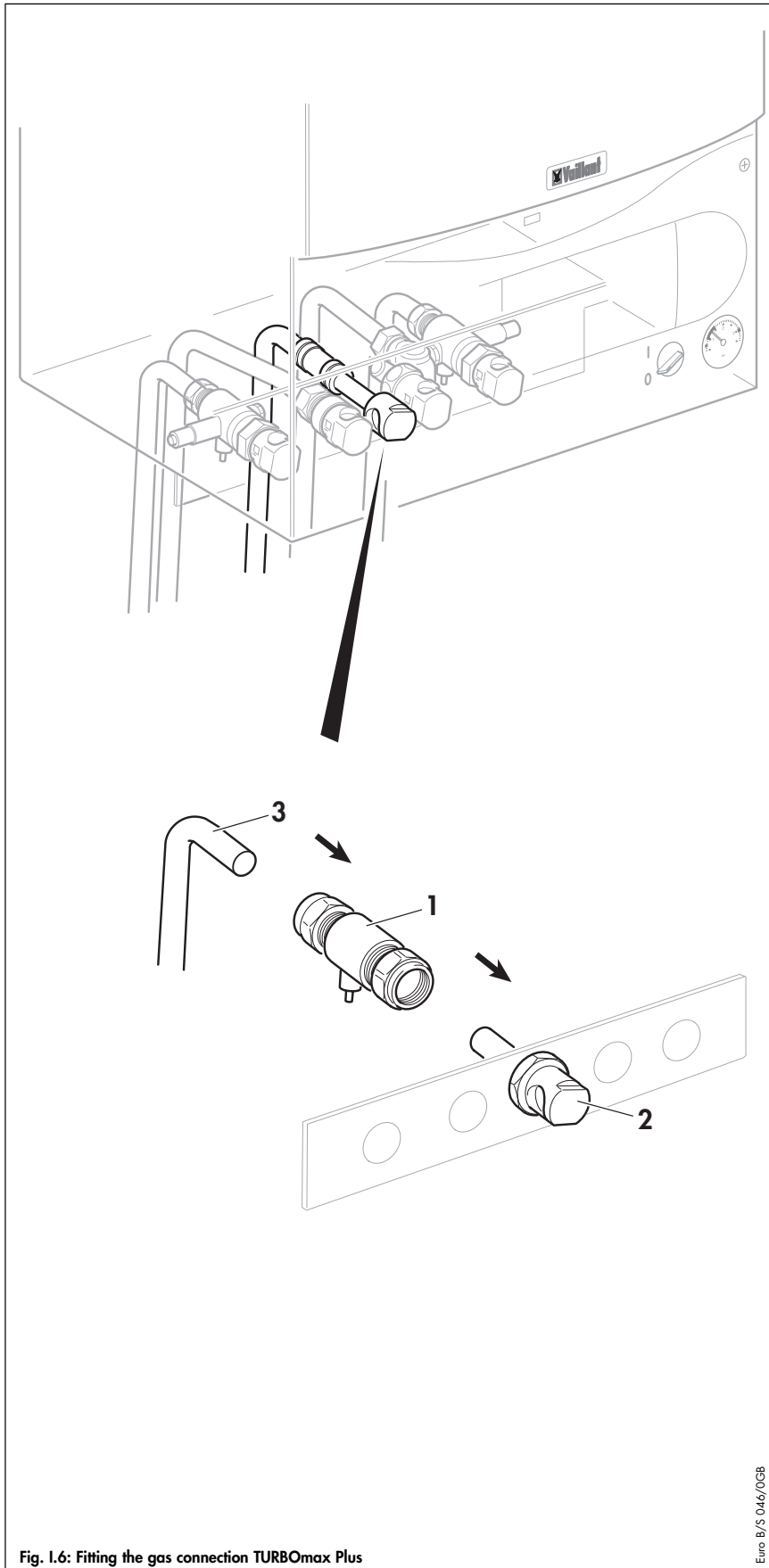
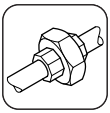

Fig. I.6: Fitting the gas connection TURBOmax Plus

Euro B/S 046/0CB



BOILER INSTALLATION SEQUENCE

TURBOmax Plus

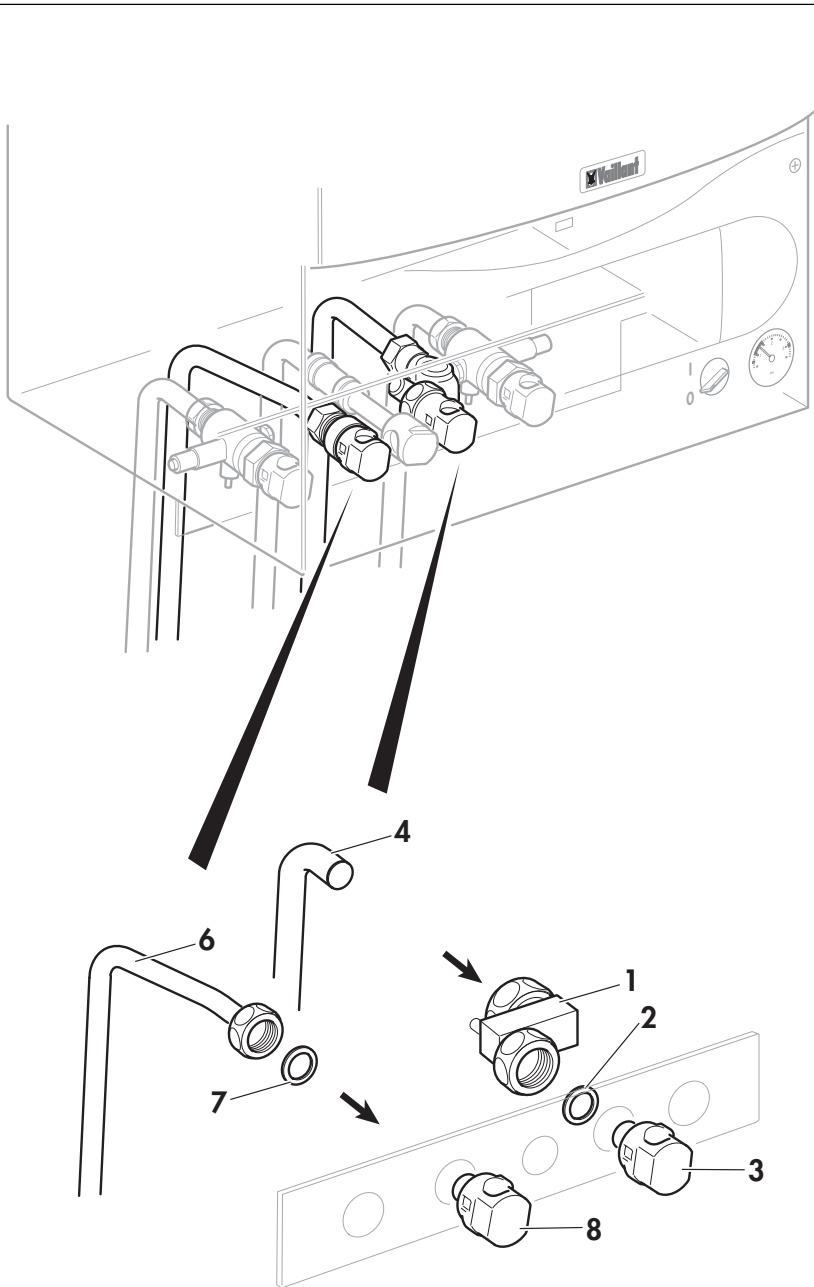

Cold water mains inlet and hot water outlet (TURBOmax Plus)

Flush all foreign matter from the mains supply before connecting to the boiler.

- Connect the cold water service valve (1) to the cold inlet water connection (3) of the appliance with the washer (2) provided and tighten.
- Connect the 15 mm cold water inlet pipe copper tail (4) to the cold water service valve (1) and tighten.
- Connect the 15 mm hot water outlet copper tail (6) to the hot water outlet connection of the appliance (8) with the washer (7) provided and tighten.

Note: The hot water outlet union nut is packed in with the PRV fitting pack.

- Connect the cold water service pipe and hot water outlet pipework to the copper tails.

Fig. I.7: Fitting the hot and cold water connections TURBOmax Plus

Euro B/S 045/0GB_Plus

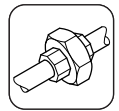

Central heating flow and return pipework (TURBOmax Plus)

Before connecting the heating circuit to the boiler appliance, all pipework and radiators must be thoroughly flushed to remove any installation debris.

- Connect the central heating flow (6) and return (1) service valves to the appliance (8 and 3) with the washers provided (2 and 7) and tighten the nuts. Ensure that the valve spindles face downwards and the drain points face to either side of the boiler.
- Connect the 22 mm copper pipe tails to the service valves as shown in the illustration and tighten the nuts.
- Connect the central heating pipework to the flow (9) and return (4) tails.

Pressure Relief Valve

Connect a discharge pipe not less than 15 mm diameter to the outlet of this valve.

The discharge pipework should be as short as possible and installed with a continuous fall away from the boiler.

The pipe should terminate in a position which ensures that any discharge of water or steam from the valve cannot create a hazard to persons in or about the premises, or cause damage to any electrical components or external wiring, and the point of discharge should be clearly visible (see diagram in plastic bag).

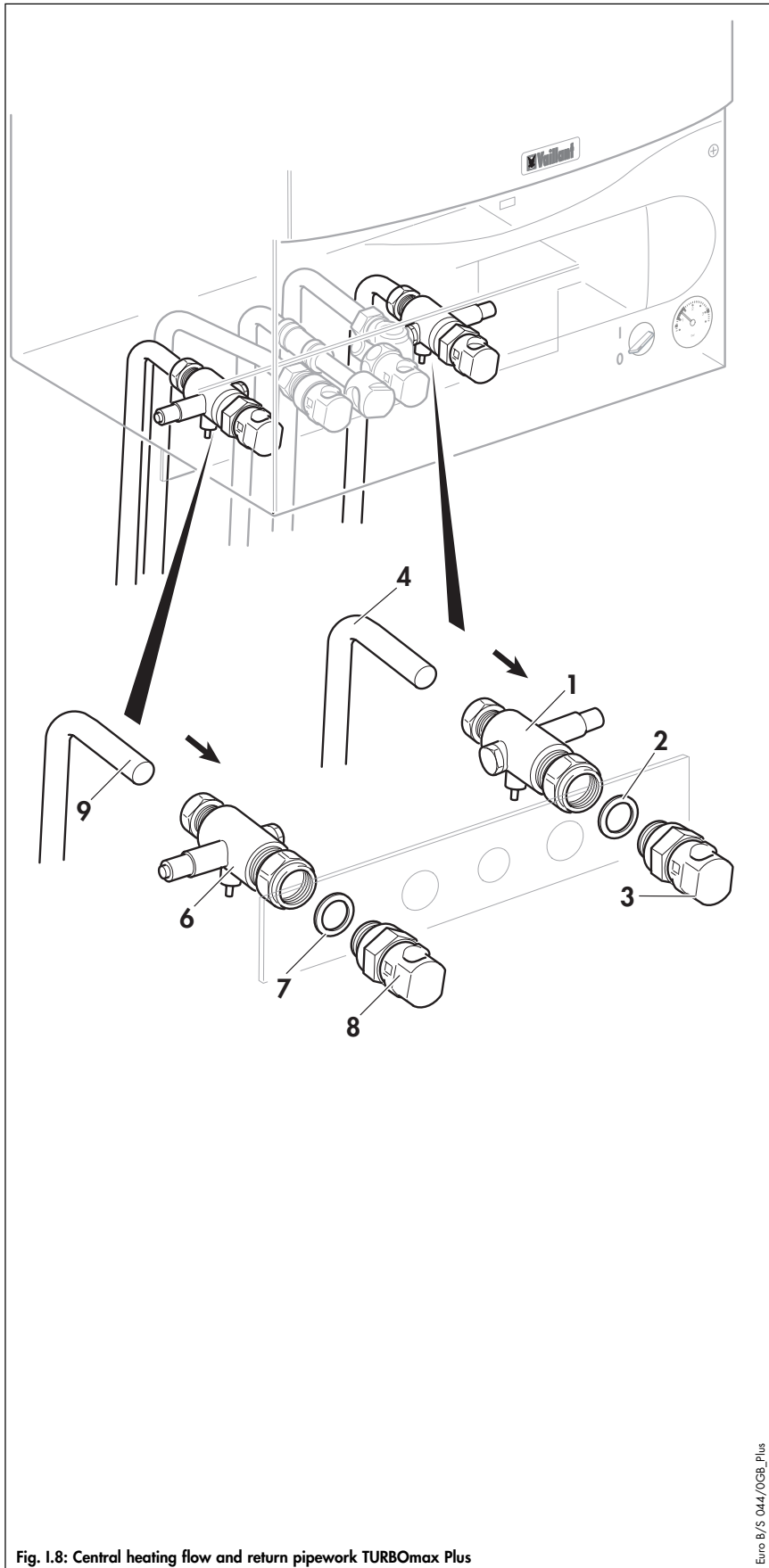
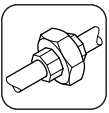
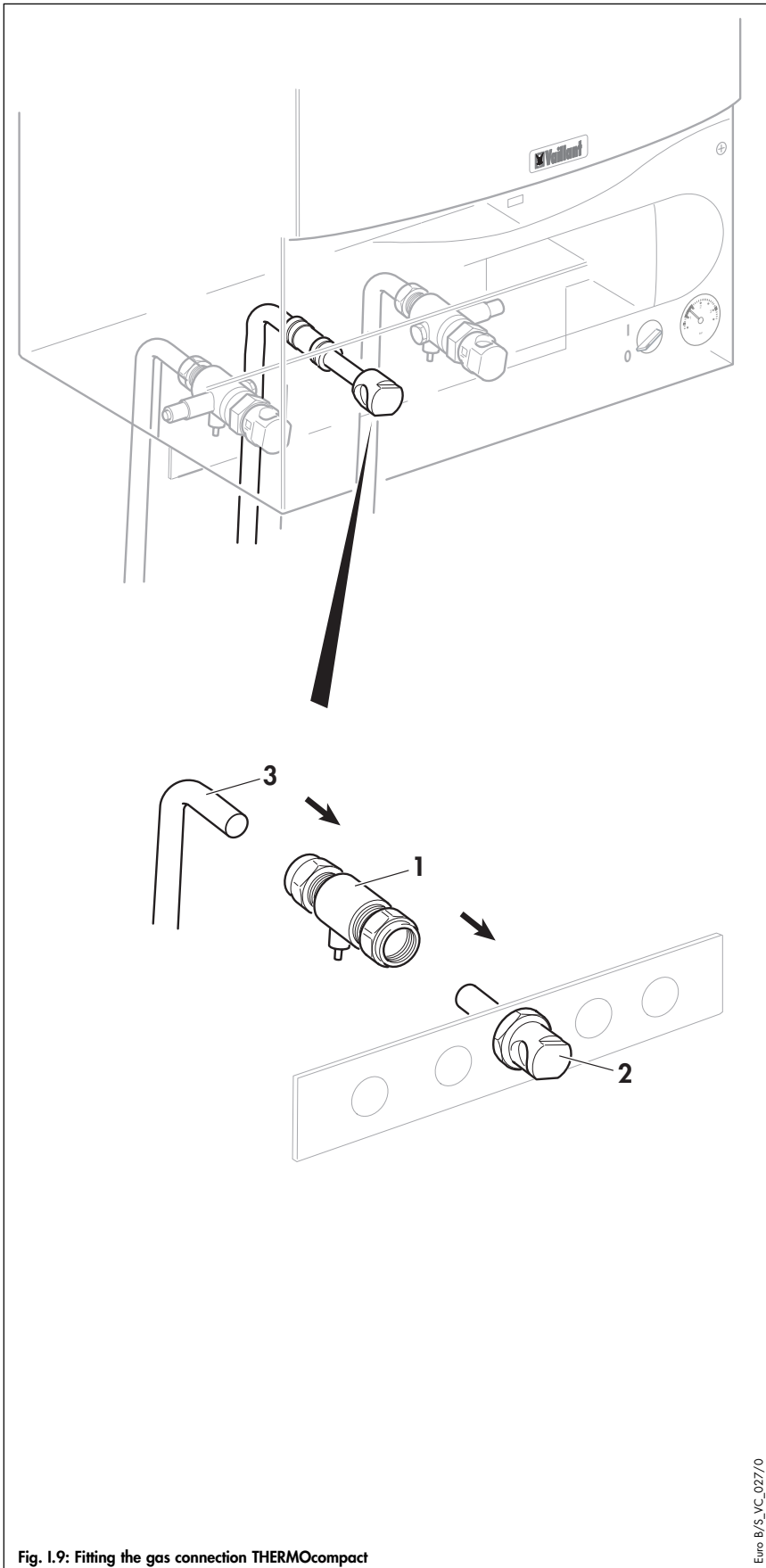

Fig. 1.8: Central heating flow and return pipework TURBOmax Plus



BOILER INSTALLATION SEQUENCE

THERMOcompact



Gas supply (THERMOcompact)

- Connect the 15 mm compression gas service cock (1) and 15 mm copper outlet tail (3) as supplied with the appliance and tighten.
- Connect a gas supply pipe of not less than 15 mm diameter to the copper tail.
- Tighten all connections.
(Ensure the gas supply pipework is adequately sized such that a 20 mbar gas pressure is available at the boiler inlet at full flow rate).

Fig. I.9: Fitting the gas connection THERMOcompact

Euro B/S_VC_027/0

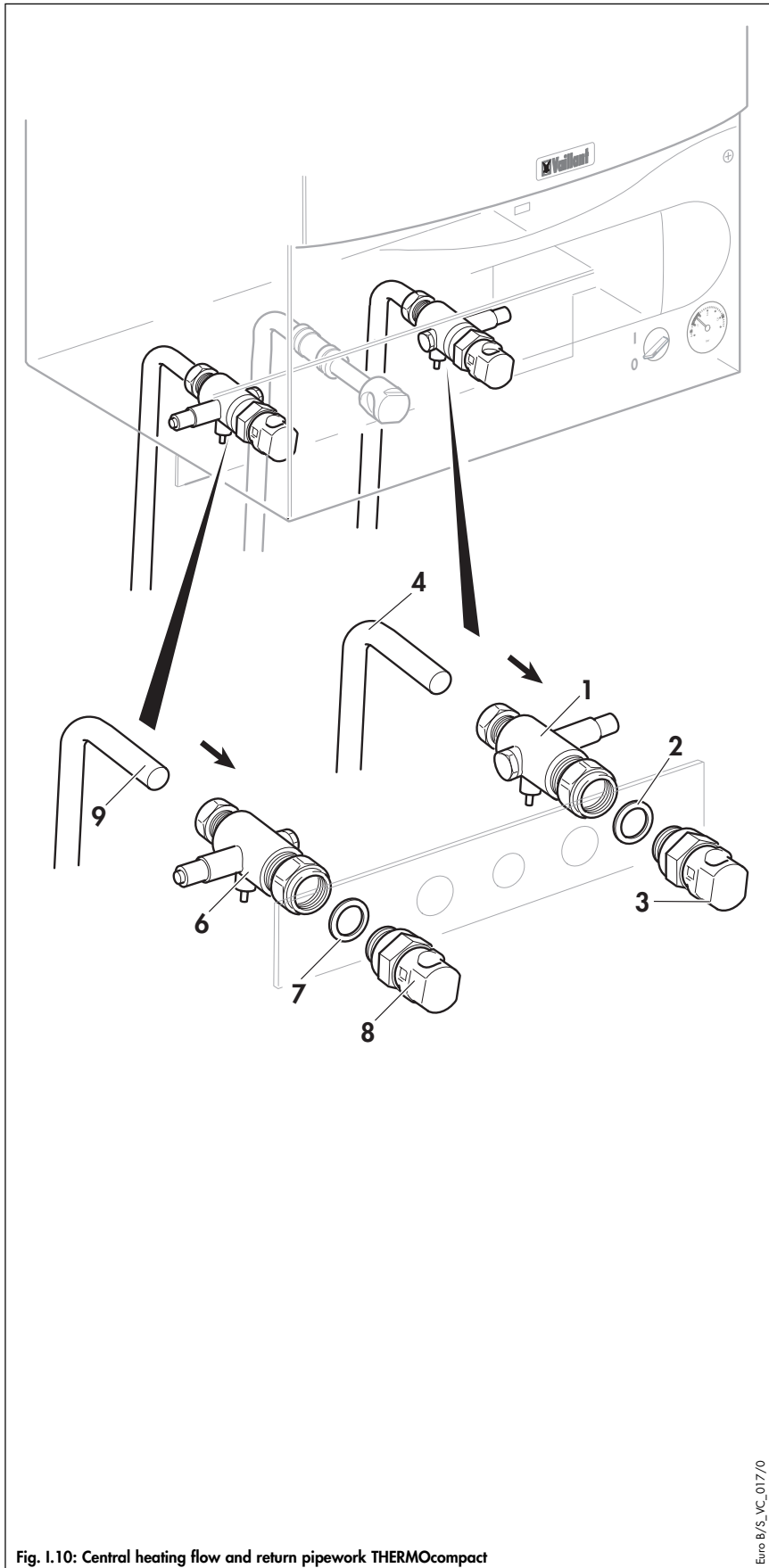
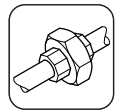

Fig. I.10: Central heating flow and return pipework THERMOcompact

Central heating flow and return pipework (THERMOcompact)

Before connecting the heating circuit to the boiler appliance, all pipework and radiators must be thoroughly flushed to remove any installation debris.

- Connect the central heating flow (6) and return (1) service valves to the appliance (8 and 3), with the washers (2 and 7) provided and tighten the nuts. Ensure that the valve spindles face downwards and the drain points face to either side of the boiler.
- Connect the 22 mm copper pipe tails to the service valves as shown in the illustration and tighten the nuts.
- Connect the central heating pipework to the flow (9) and return (4) tails.

Pressure Relief Valve

Connect a discharge pipe not less than 15 mm diameter to the outlet of this valve.

The discharge pipework should be as short as possible and installed with a continuous fall away from the boiler.

The pipe should terminate in a position which ensures that any discharge of water or steam from the valve cannot create a hazard to persons in or about the premises, or cause damage to any electrical components or external wiring, and the point of discharge should be clearly visible (see diagram in plastic bag).

THERMOcompact

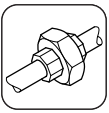

BOILER INSTALLATION SEQUENCE

Connection to a Vantage unvented cylinder (THERMOcompact)

- For connecting a Vaillant Vantage unvented cylinder please refer to the Vantage installation instructions provided with the cylinder.

Connect the flue system to the boiler

- Refer to separate air/flue duct installation instructions included with the boiler.

BOILER INSTALLATION SEQUENCE

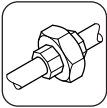

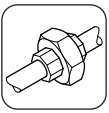

BOILER INSTALLATION SEQUENCE

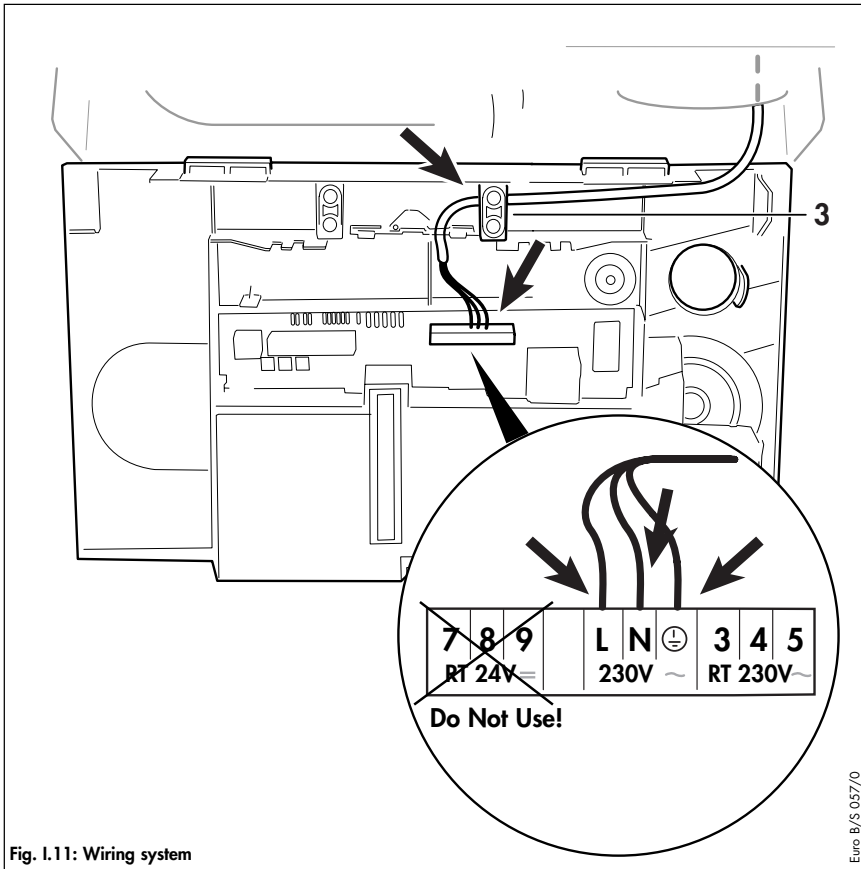

Fig. I.11: Wiring system

Euro B/S 037/0

Electrical installation General requirements

All electrical work shall be carried out by a competent person and shall comply with BS7671 (IEE Regulations).

The boiler is supplied for connection to 230 V, ~ 50 Hz supply fused at 3 A rating.

Connection to the mains supply shall be made via a fused 3 pin plug to an unswitched shuttered socket, both complying to the requirements of BS1363.

(Alternatively, connection may be made via a 3 A fused double pole isolator having a contact separation of at least 3 mm in all poles and supplying the boiler and controls only).

The point of connection to the mains supply must allow complete electrical isolation of the boiler and its ancillary controls. It should be readily accessible and adjacent to the boiler. A 3 core flexible cord according to BS6500 tables 6, 8 or 16 (3 x 0.75 to 3 x 1.5 mm²) should be used.

Warning: This appliance must be earthed.

Note: DO NOT use boiler terminal connections 7-8-9.

Important: Ensure that all cords pass through the cable clamps in the rear of the control box and are securely fixed. Ensure that the power supply is connected such that the current carrying conductors become taut before the earth conductor should the supply cord slip from the cable clamp.

picture shows
TURBOmax appliance

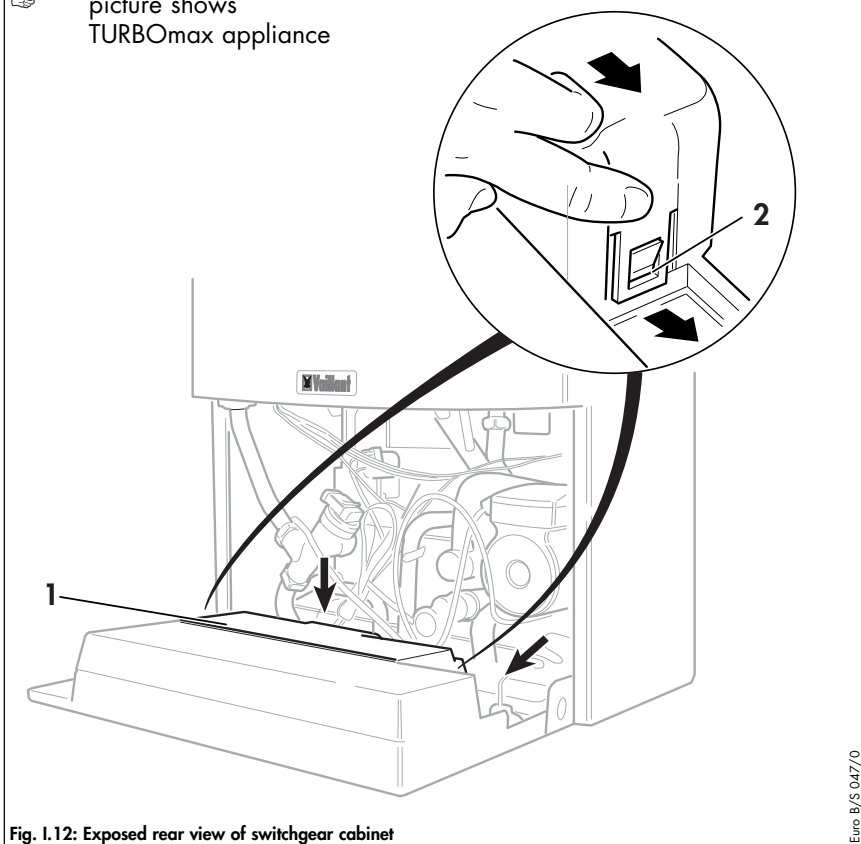
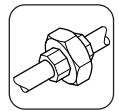

Fig. I.12: Exposed rear view of switchgear cabinet

Euro B/S 047/0



Caution

Mains connection terminals L and N remain live even when the boiler on/off control is switched off.

Connection to the main supply

- Lower the control panel.
- Unclip the terminal box cover (1) from the control panel (2).
- Feed the power supply cord in to the appliance as shown (fig I.11).
- Use cable clamps.
- Connect the power supply cord as follows (Fig. I.13, on page 32).
- Refit the terminal box cover by pushing into place until it clips back into position.
- Raise the control panel and secure in place.

Green/yellow (earth) wire
boiler terminal Earth sign
Blue (neutral) wire
boiler terminal N
Brown (live) wire
boiler terminal L

Note: DO NOT use boiler terminal connections 7-8-9.

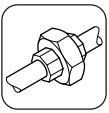

BOILER INSTALLATION SEQUENCE

Electronic board layout

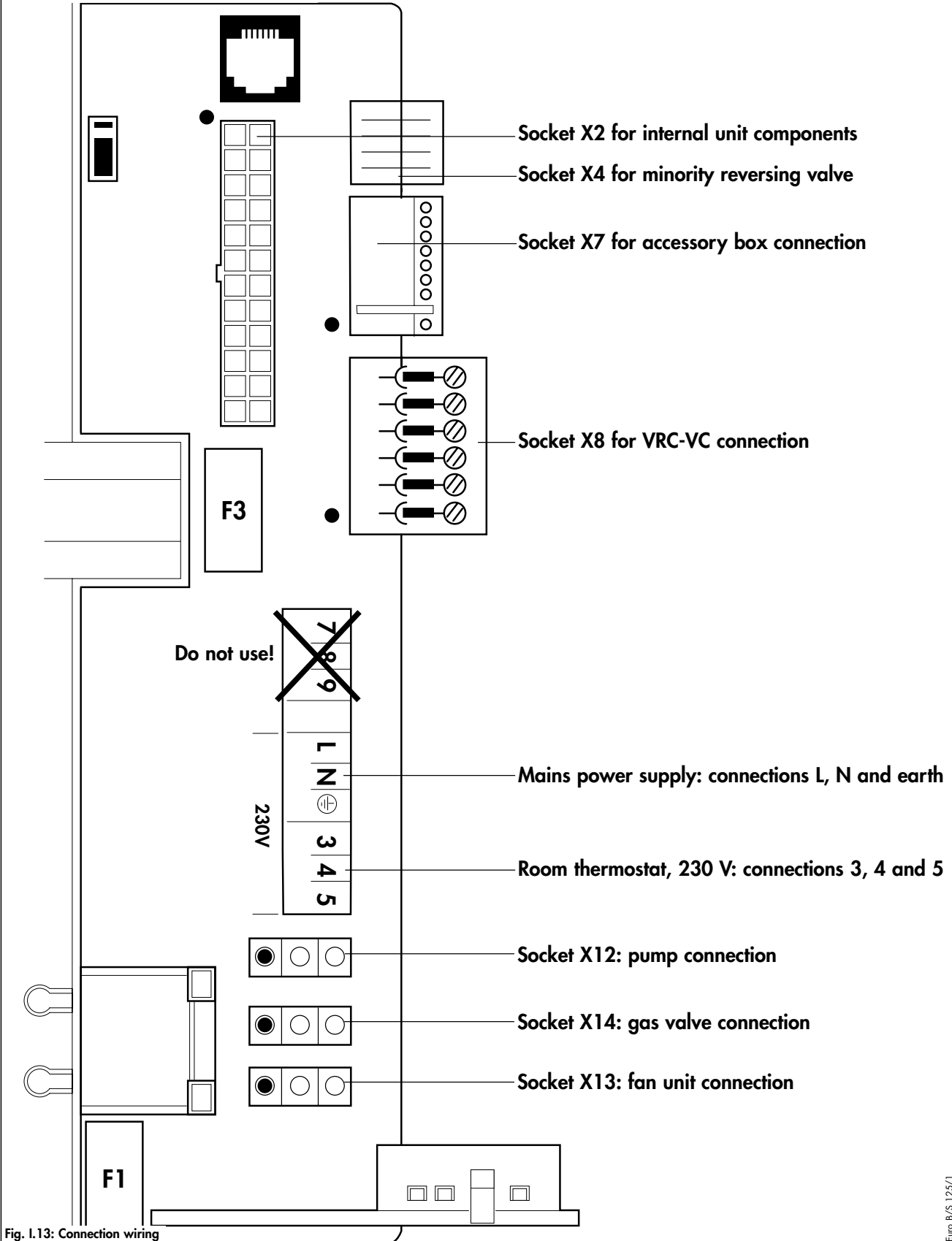
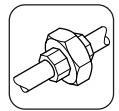

Fig. I.13: Connection wiring



Connection details for programmable thermostats																												
ACL Drayton Lifestyle PT271, PT371	<table border="1"> <tr><td>L</td><td>N</td><td>1</td><td>2</td><td>3</td><td>4</td></tr> <tr><td>↓</td><td>↓</td><td>↓</td><td>↓</td><td>↓</td><td>↓</td></tr> <tr><td>L</td><td>N</td><td>3</td><td></td><td>4</td><td></td></tr> </table>	L	N	1	2	3	4	↓	↓	↓	↓	↓	↓	L	N	3		4										
L	N	1	2	3	4																							
↓	↓	↓	↓	↓	↓																							
L	N	3		4																								
ACL Drayton Digistat 2, 3, 4	<table border="1"> <tr><td>1</td><td>2</td><td>3</td></tr> <tr><td>↓</td><td>↓</td><td>↓</td></tr> <tr><td>3</td><td></td><td>4</td></tr> </table>	1	2	3	↓	↓	↓	3		4																		
1	2	3																										
↓	↓	↓																										
3		4																										
ACL Drayton Digistat RF - SCR Receiver	<table border="1"> <tr><td>L</td><td>N</td><td>1</td><td>2</td><td>3</td></tr> <tr><td>↓</td><td>↓</td><td>↓</td><td>↓</td><td>↓</td></tr> <tr><td>L</td><td>N</td><td>3</td><td></td><td>4</td></tr> </table>	L	N	1	2	3	↓	↓	↓	↓	↓	L	N	3		4												
L	N	1	2	3																								
↓	↓	↓	↓	↓																								
L	N	3		4																								
Danfoss Randall TP4, TP5, TP5E	<table border="1"> <tr><td>3</td><td>2</td><td>1</td></tr> <tr><td>↓</td><td>↓</td><td>↓</td></tr> <tr><td>4</td><td></td><td>3</td></tr> </table>	3	2	1	↓	↓	↓	4		3																		
3	2	1																										
↓	↓	↓																										
4		3																										
Danfoss Randall TP5E RF with receiver RX1	<table border="1"> <tr><td>L</td><td>N</td><td>1</td><td>2</td><td>3</td><td>4</td></tr> <tr><td>↓</td><td>↓</td><td>↓</td><td>↓</td><td>↓</td><td>↓</td></tr> <tr><td>L</td><td>N</td><td></td><td>3</td><td>4</td><td></td></tr> </table>	L	N	1	2	3	4	↓	↓	↓	↓	↓	↓	L	N		3	4										
L	N	1	2	3	4																							
↓	↓	↓	↓	↓	↓																							
L	N		3	4																								
Danfoss Randall TP75	<table border="1"> <tr><td>A</td><td>B</td><td>C</td><td>1</td><td>2</td><td>3</td><td>4</td><td>5</td><td>6</td></tr> <tr><td>↓</td><td>↓</td><td>↓</td><td>↓</td><td>↓</td><td>↓</td><td>↓</td><td>↓</td><td>↓</td></tr> <tr><td></td><td></td><td></td><td></td><td></td><td>3</td><td></td><td>4</td><td></td></tr> </table>	A	B	C	1	2	3	4	5	6	↓	↓	↓	↓	↓	↓	↓	↓	↓						3		4	
A	B	C	1	2	3	4	5	6																				
↓	↓	↓	↓	↓	↓	↓	↓	↓																				
					3		4																					
Grässlin Towerchron RTC7	<table border="1"> <tr><td>1</td><td>2</td><td>3</td></tr> <tr><td>↓</td><td>↓</td><td>↓</td></tr> <tr><td>3</td><td></td><td>4</td></tr> </table>	1	2	3	↓	↓	↓	3		4																		
1	2	3																										
↓	↓	↓																										
3		4																										
Honeywell CM61, CM67, CM31, CM37	<table border="1"> <tr><td>A</td><td>B</td><td>C</td></tr> <tr><td>↓</td><td>↓</td><td>↓</td></tr> <tr><td>3</td><td></td><td>4</td></tr> </table>	A	B	C	↓	↓	↓	3		4																		
A	B	C																										
↓	↓	↓																										
3		4																										
Horstmann Centaurstat 1, 7	<table border="1"> <tr><td>1</td><td>2</td><td>3</td><td>4</td></tr> <tr><td>↓</td><td>↓</td><td>↓</td><td>↓</td></tr> <tr><td>3</td><td></td><td>4</td><td></td></tr> </table>	1	2	3	4	↓	↓	↓	↓	3		4																
1	2	3	4																									
↓	↓	↓	↓																									
3		4																										
Landis & Staefa REV 11, REV 15, REV 22	<table border="1"> <tr><td>L</td><td>L1</td></tr> <tr><td>↓</td><td>↓</td></tr> <tr><td>3</td><td>4</td></tr> </table>	L	L1	↓	↓	3	4																					
L	L1																											
↓	↓																											
3	4																											
Smiths Timeguard ProgramaSTAT PRT11, PRT17	<table border="1"> <tr><td>L</td><td>N</td><td>3</td><td>4</td></tr> <tr><td>↓</td><td>↓</td><td>↓</td><td>↓</td></tr> <tr><td>L</td><td>N</td><td>3</td><td>4</td></tr> </table>	L	N	3	4	↓	↓	↓	↓	L	N	3	4															
L	N	3	4																									
↓	↓	↓	↓																									
L	N	3	4																									
Sunvic TLX 6501	<table border="1"> <tr><td>1</td><td>2</td><td>3</td></tr> <tr><td>↓</td><td>↓</td><td>↓</td></tr> <tr><td>3</td><td></td><td>4</td></tr> </table>	1	2	3	↓	↓	↓	3		4																		
1	2	3																										
↓	↓	↓																										
3		4																										
Sunvic TLX RFP, TLX RFD	<table border="1"> <tr><td>L</td><td>N</td><td>1</td><td>2</td><td>3</td><td>4</td></tr> <tr><td>↓</td><td>↓</td><td>↓</td><td>↓</td><td>↓</td><td>↓</td></tr> <tr><td>L</td><td>N</td><td></td><td>3</td><td>4</td><td></td></tr> </table>	L	N	1	2	3	4	↓	↓	↓	↓	↓	↓	L	N		3	4										
L	N	1	2	3	4																							
↓	↓	↓	↓	↓	↓																							
L	N		3	4																								
Vaillant VRT 9083QT, VRT 9084QW	<table border="1"> <tr><td>F</td><td>9</td><td>7</td><td>8</td></tr> <tr><td>↓</td><td>↓</td><td>↓</td><td>↓</td></tr> <tr><td>L</td><td>N</td><td>3</td><td>4</td></tr> </table>	F	9	7	8	↓	↓	↓	↓	L	N	3	4															
F	9	7	8																									
↓	↓	↓	↓																									
L	N	3	4																									

Fig. I.14

Controls (TURBOmax Plus boiler)

External electrical controls

The boiler terminals 3, 4 and 5 are for connecting external electrical controls such as a time switch and/or room thermostat.

Terminals 3 and 4 are linked together when the boiler is supplied. If external controls are used, this link must be removed, and the controls connected across terminals 3 and 4.

Terminal 5 is an additional neutral connection for external neutrals such as from the anticipator of a room thermostat.

Connection of external controls

Connection details for programmable room thermostats.

Fig. I.14 shows the connection details where a programmable room thermostat (time switch with built in room thermostat) is used to control the boiler.

Important: The arrowed numbers indicate connection into the relevant terminal in the boiler terminal strip.

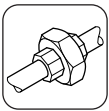

BOILER INSTALLATION SEQUENCE

TURBOMAX PLUS

Connection details for time switch																																								
ACL Drayton Tempus 1, Tempus 2 Lystyle LP111, LP711	<table border="1"> <tr><td>L</td><td>N</td><td>1</td><td>2</td><td>3</td><td>4</td></tr> <tr><td>↓</td><td>↓</td><td>↓</td><td>↓</td><td>↓</td><td>↓</td></tr> <tr><td>L</td><td>N</td><td>3</td><td></td><td>4</td><td></td></tr> </table>	L	N	1	2	3	4	↓	↓	↓	↓	↓	↓	L	N	3		4																						
L	N	1	2	3	4																																			
↓	↓	↓	↓	↓	↓																																			
L	N	3		4																																				
ACL Drayton Switchmaster SM300	<table border="1"> <tr><td>L</td><td>N</td><td>1</td><td>2</td><td>3</td><td>4</td></tr> <tr><td>↓</td><td>↓</td><td>↓</td><td>↓</td><td>↓</td><td>↓</td></tr> <tr><td>L</td><td>N</td><td>4</td><td></td><td>3</td><td></td></tr> </table>	L	N	1	2	3	4	↓	↓	↓	↓	↓	↓	L	N	4		3																						
L	N	1	2	3	4																																			
↓	↓	↓	↓	↓	↓																																			
L	N	4		3																																				
ACL Drayton Switchmaster 980	<table border="1"> <tr><td>L</td><td>N</td><td>1</td><td>2</td><td>A</td><td>B</td><td>C</td><td>3</td><td>4</td></tr> <tr><td>↓</td><td>↓</td><td>↓</td><td>↓</td><td>↓</td><td>↓</td><td>↓</td><td>↓</td><td>↓</td></tr> <tr><td>L</td><td>N</td><td>4</td><td></td><td></td><td></td><td></td><td>3</td><td></td></tr> </table>	L	N	1	2	A	B	C	3	4	↓	↓	↓	↓	↓	↓	↓	↓	↓	L	N	4					3													
L	N	1	2	A	B	C	3	4																																
↓	↓	↓	↓	↓	↓	↓	↓	↓																																
L	N	4					3																																	
Danfoss Randall 103 Series	<table border="1"> <tr><td>1</td><td>2</td><td>3</td><td>6</td><td>5</td><td>E</td></tr> <tr><td>↓</td><td>↓</td><td>↓</td><td>↓</td><td>↓</td><td>↓</td></tr> <tr><td>4</td><td></td><td>3</td><td>L</td><td>N</td><td>E</td></tr> </table>	1	2	3	6	5	E	↓	↓	↓	↓	↓	↓	4		3	L	N	E																					
1	2	3	6	5	E																																			
↓	↓	↓	↓	↓	↓																																			
4		3	L	N	E																																			
Danfoss Randall Set 1E, TS975	<table border="1"> <tr><td>L</td><td>N</td><td>E</td><td>1</td><td>2</td><td>3</td><td>4</td><td>5</td><td>6</td></tr> <tr><td>↓</td><td>↓</td><td>↓</td><td>↓</td><td>↓</td><td>↓</td><td>↓</td><td>↓</td><td>↓</td></tr> <tr><td>L</td><td>N</td><td>E</td><td></td><td></td><td></td><td>4</td><td>3</td><td></td></tr> </table>	L	N	E	1	2	3	4	5	6	↓	↓	↓	↓	↓	↓	↓	↓	↓	L	N	E				4	3													
L	N	E	1	2	3	4	5	6																																
↓	↓	↓	↓	↓	↓	↓	↓	↓																																
L	N	E				4	3																																	
Danfoss Randall TS715	<table border="1"> <tr><td>L</td><td>N</td><td>1</td><td>2</td><td>3</td><td>4</td></tr> <tr><td>↓</td><td>↓</td><td>↓</td><td>↓</td><td>↓</td><td>↓</td></tr> <tr><td>L</td><td>N</td><td>3</td><td></td><td></td><td>4</td></tr> </table>	L	N	1	2	3	4	↓	↓	↓	↓	↓	↓	L	N	3			4																					
L	N	1	2	3	4																																			
↓	↓	↓	↓	↓	↓																																			
L	N	3			4																																			
Grässlin Towerchron QE1, GM1	<table border="1"> <tr><td>L</td><td>N</td><td>1</td><td>2</td><td>3</td><td>4</td></tr> <tr><td>↓</td><td>↓</td><td>↓</td><td>↓</td><td>↓</td><td>↓</td></tr> <tr><td>L</td><td>N</td><td></td><td>3</td><td>4</td><td></td></tr> </table>	L	N	1	2	3	4	↓	↓	↓	↓	↓	↓	L	N		3	4																						
L	N	1	2	3	4																																			
↓	↓	↓	↓	↓	↓																																			
L	N		3	4																																				
Honeywell ST610A, ST6100C	<table border="1"> <tr><td>L</td><td>N</td><td>1</td><td>2</td><td>3</td><td>4</td></tr> <tr><td>↓</td><td>↓</td><td>↓</td><td>↓</td><td>↓</td><td>↓</td></tr> <tr><td>L</td><td>N</td><td>3</td><td></td><td></td><td>4</td></tr> </table>	L	N	1	2	3	4	↓	↓	↓	↓	↓	↓	L	N	3			4																					
L	N	1	2	3	4																																			
↓	↓	↓	↓	↓	↓																																			
L	N	3			4																																			
Horsmann Channel Plus H11, H17, 425 Coronet	<table border="1"> <tr><td>L</td><td>N</td><td>E</td><td>1</td><td>2</td><td>3</td><td>4</td><td>5</td><td>6</td></tr> <tr><td>↓</td><td>↓</td><td>↓</td><td>↓</td><td>↓</td><td>↓</td><td>↓</td><td>↓</td><td>↓</td></tr> <tr><td>L</td><td>N</td><td>E</td><td></td><td></td><td></td><td>4</td><td>3</td><td></td></tr> </table>	L	N	E	1	2	3	4	5	6	↓	↓	↓	↓	↓	↓	↓	↓	↓	L	N	E				4	3													
L	N	E	1	2	3	4	5	6																																
↓	↓	↓	↓	↓	↓	↓	↓	↓																																
L	N	E				4	3																																	
Horsmann Centaur Plus C11, C17	<table border="1"> <tr><td>L</td><td>N</td><td>E</td><td>1</td><td>2</td><td>3</td><td>4</td></tr> <tr><td>↓</td><td>↓</td><td>↓</td><td>↓</td><td>↓</td><td>↓</td><td>↓</td></tr> <tr><td>L</td><td>N</td><td>E</td><td></td><td>3</td><td></td><td>4</td></tr> </table>	L	N	E	1	2	3	4	↓	↓	↓	↓	↓	↓	↓	L	N	E		3		4																		
L	N	E	1	2	3	4																																		
↓	↓	↓	↓	↓	↓	↓																																		
L	N	E		3		4																																		
Landis & Staefa RWB7, RWB30	<table border="1"> <tr><td>L</td><td>N</td><td>1</td><td>2</td><td>3</td><td>4</td></tr> <tr><td>↓</td><td>↓</td><td>↓</td><td>↓</td><td>↓</td><td>↓</td></tr> <tr><td>L</td><td>N</td><td></td><td>3</td><td></td><td>4</td></tr> </table>	L	N	1	2	3	4	↓	↓	↓	↓	↓	↓	L	N		3		4																					
L	N	1	2	3	4																																			
↓	↓	↓	↓	↓	↓																																			
L	N		3		4																																			
Potterton Myson EP 4002, EP 5002	<table border="1"> <tr><td>N</td><td>A</td><td>B</td><td>C</td><td>D</td><td>L</td><td>N</td><td>1</td><td>2</td><td>3</td><td>4</td><td>5</td><td>E</td></tr> <tr><td></td><td></td><td></td><td></td><td></td><td>↓</td><td>↓</td><td>↓</td><td>↓</td><td>↓</td><td>↓</td><td>↓</td><td>↓</td></tr> <tr><td></td><td></td><td></td><td></td><td></td><td>L</td><td>N</td><td></td><td></td><td></td><td>4</td><td>3</td><td>E</td></tr> </table>	N	A	B	C	D	L	N	1	2	3	4	5	E						↓	↓	↓	↓	↓	↓	↓	↓						L	N				4	3	E
N	A	B	C	D	L	N	1	2	3	4	5	E																												
					↓	↓	↓	↓	↓	↓	↓	↓																												
					L	N				4	3	E																												
Smiths Timeguard SupplyMASTER FST11, FST17	<table border="1"> <tr><td>1</td><td>2</td><td>3</td><td>4</td><td>6</td><td>5</td><td>E</td><td>mains supply</td></tr> <tr><td>↓</td><td>↓</td><td>↓</td><td>↓</td><td>↓</td><td>↓</td><td>↓</td><td></td></tr> <tr><td>4</td><td>3</td><td>2/L</td><td>1/N</td><td>L</td><td>N</td><td>E</td><td></td></tr> </table>	1	2	3	4	6	5	E	mains supply	↓	↓	↓	↓	↓	↓	↓		4	3	2/L	1/N	L	N	E																
1	2	3	4	6	5	E	mains supply																																	
↓	↓	↓	↓	↓	↓	↓																																		
4	3	2/L	1/N	L	N	E																																		
Sunvic Select 107	<table border="1"> <tr><td>L</td><td>N</td><td>1</td><td>2</td><td>3</td><td>4</td></tr> <tr><td>↓</td><td>↓</td><td>↓</td><td>↓</td><td>↓</td><td>↓</td></tr> <tr><td>L</td><td>N</td><td>3</td><td></td><td></td><td>4</td></tr> </table>	L	N	1	2	3	4	↓	↓	↓	↓	↓	↓	L	N	3			4																					
L	N	1	2	3	4																																			
↓	↓	↓	↓	↓	↓																																			
L	N	3			4																																			

Fig. I.15

Connection details for external time switches and boiler terminal strip.

Fig. I.15 shows the connection details where a time switch is used without a room thermostat to control the boiler.

Important: The arrowed numbers indicate connection into the relevant terminal in the boiler terminal strip.

If a room thermostat is to be connected in addition to a time switch the wire between the time switch „ON“ terminal and boiler terminal 4 should be broken by the contacts of the room thermostat (see schematic layout, Fig. I.16).

Vaillant optional plug in timer accessories

Refer to the instructions supplied with the optional accessories for connection details.

Upon completion of all electrical connections refit the terminal box cover by pushing into place. The cover is secured by two locking clips.

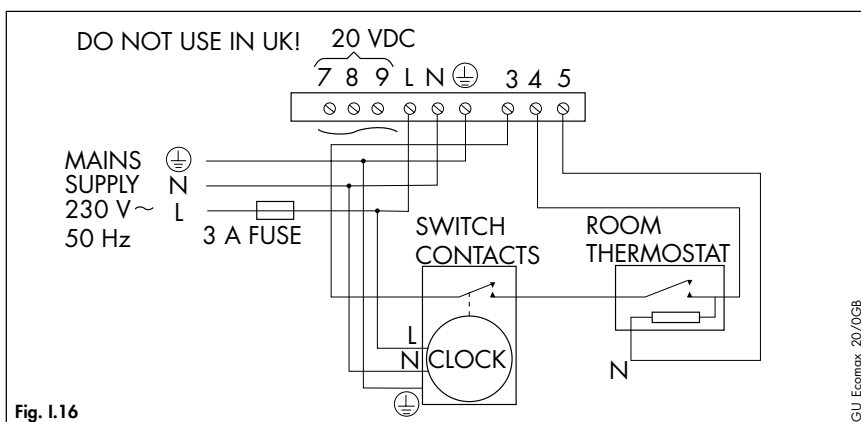

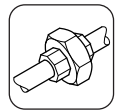

Connection details for control systems utilising 3 port motorised valve via external wiring centre/junction box

Diagram only applies to the specific controls mentioned

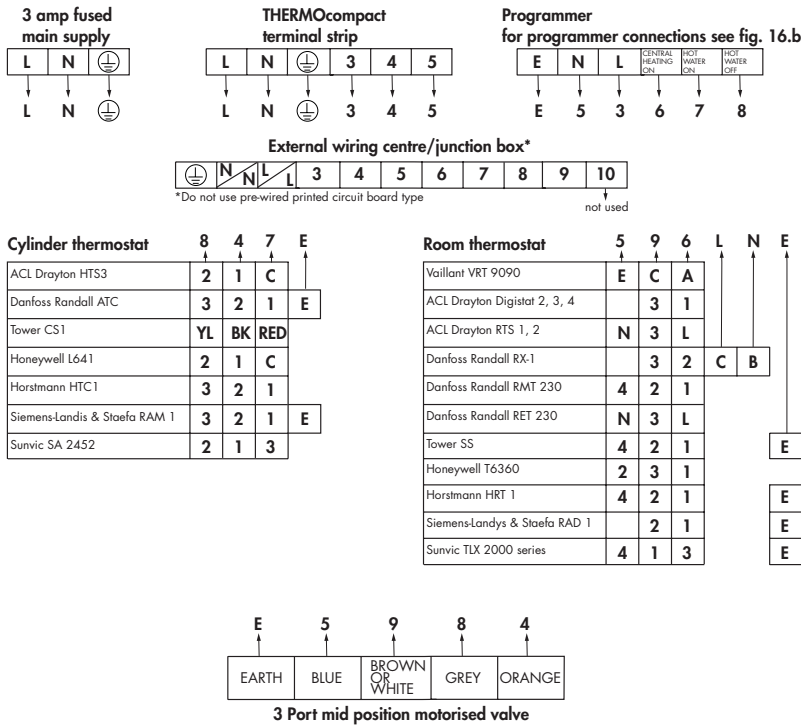

Fig. I.17

Controls (THERMOcompact boiler)

External electrical controls

The boiler terminals 3, 4 and 5 are for connecting external electrical controls such as a programmer, room thermostat, etc.

Terminals 3 and 4 are linked together when the boiler is supplied. If external controls are used, this link must be removed, and the controls connected across terminals 3 and 4.

Terminal 5 is an additional neutral connection for external controls.

Connection of external electrical controls

Connection details using an external wiring centre

The boiler should be connected to the system controls using an external wiring centre. Fig. 17, 18 shows connection details for a system utilising a 3 port mid position motorised valve, figure 19, 20 shows the connection details for a system utilising two 2 port motorised valves connected via an external wiring centre (Important: the arrowed numbers indicate connection into the relevant terminal of three external wiring centre).

Lifestyle LP241, LP 522, LP 722	N L 1 2 3 4 5 3 8 not used 7 6
Tempus 6, Tempus 7	E N L 1 2 3 4 5 3 8 not used 7 6
Danfoss Randall CP 715, FP715 Note: *Earth not required	E N L 1 2 3 4 * 5 3 8 not used 7 6
Danfoss Randall Set 2E, Set 3E Note: *Earth not required, Link L - 2 - 5	E N L 1 2 3 4 5 6 * 5 3 7 8 6 not used
Grässlin Towerchron QE2	N L 1 2 3 4 5 3 8 not used 7 6
Honeywell ST699B, ST799A Note: Link L - 5 - 8	L N 3 4 5 6 7 8 3 5 6 not used 7 8
Honeywell ST6200, ST6300, ST6400	N L 1 2 3 4 5 3 8 not used 7 6
Horstmann Channel Plus H21, H27 Note: *Earth not required, Link L - 2 - 5	E N L 1 2 3 4 5 6 * 5 3 7 8 6 not used
Siemens-Landis & Staefa RWB2, RWB9	N L 1 2 3 4 5 3 8 not used 7 6
Potterton Myson EP 2002, EP 3002, EP 6002 Note: Link L - 5	E N L 1 2 3 4 5 5 3 8 not used 7 6
Sunvic Select 207	N L 1 2 3 4 5 3 8 not used 7 6

Fig. I.18

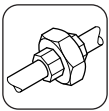

BOILER INSTALLATION SEQUENCE

THERMOcompact

Connection details for control systems utilising 2 x 2 port motorised valves via external wiring centre/junction box

Diagram only applies to the specific controls mentioned

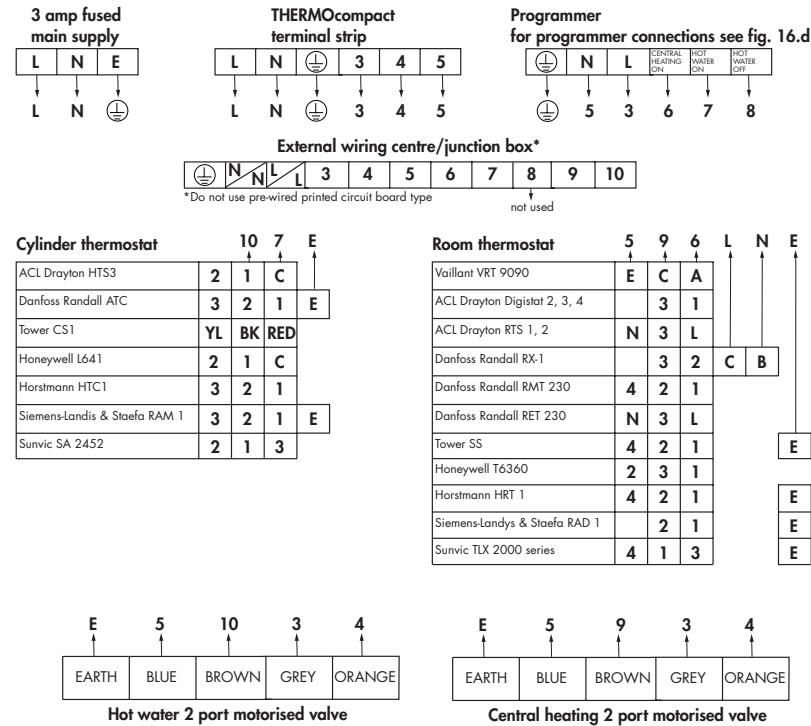
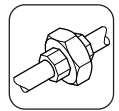

Fig. I.19

Lifestyle LP241, LP 522, LP 722	<table border="1"> <tr><td>N</td><td>L</td><td>1</td><td>2</td><td>3</td><td>4</td></tr> <tr><td>5</td><td>3</td><td>not used</td><td>7</td><td>6</td><td></td></tr> </table>	N	L	1	2	3	4	5	3	not used	7	6							
N	L	1	2	3	4														
5	3	not used	7	6															
Tempus 6, Tempus 7	<table border="1"> <tr><td>E</td><td>N</td><td>L</td><td>1</td><td>2</td><td>3</td><td>4</td></tr> <tr><td>⊕</td><td>5</td><td>3</td><td>not used</td><td>7</td><td>6</td><td></td></tr> </table>	E	N	L	1	2	3	4	⊕	5	3	not used	7	6					
E	N	L	1	2	3	4													
⊕	5	3	not used	7	6														
Danfoss Randall CP 715, FP715	<table border="1"> <tr><td>E</td><td>N</td><td>L</td><td>1</td><td>2</td><td>3</td><td>4</td></tr> <tr><td>*</td><td>5</td><td>3</td><td>not used</td><td>7</td><td>6</td><td></td></tr> </table>	E	N	L	1	2	3	4	*	5	3	not used	7	6					
E	N	L	1	2	3	4													
*	5	3	not used	7	6														
Danfoss Randall Set 2E, Set 3E Note: *Earth not required, Link L - 2 - 5	<table border="1"> <tr><td>E</td><td>N</td><td>L</td><td>1</td><td>2</td><td>3</td><td>4</td><td>5</td><td>6</td></tr> <tr><td>*</td><td>5</td><td>3</td><td>7</td><td>not used</td><td>6</td><td>not used</td><td></td><td></td></tr> </table>	E	N	L	1	2	3	4	5	6	*	5	3	7	not used	6	not used		
E	N	L	1	2	3	4	5	6											
*	5	3	7	not used	6	not used													
Grässlin Towerchron QE2	<table border="1"> <tr><td>N</td><td>L</td><td>1</td><td>2</td><td>3</td><td>4</td></tr> <tr><td>5</td><td>3</td><td>not used</td><td>7</td><td>6</td><td></td></tr> </table>	N	L	1	2	3	4	5	3	not used	7	6							
N	L	1	2	3	4														
5	3	not used	7	6															
Honeywell ST699B, ST799A Note: Link L - 5 - 8	<table border="1"> <tr><td>L</td><td>N</td><td>3</td><td>4</td><td>5</td><td>6</td><td>7</td><td>8</td></tr> <tr><td>3</td><td>5</td><td>6</td><td>not used</td><td>7</td><td>not used</td><td></td><td></td></tr> </table>	L	N	3	4	5	6	7	8	3	5	6	not used	7	not used				
L	N	3	4	5	6	7	8												
3	5	6	not used	7	not used														
Honeywell ST6200, ST6300, ST6400	<table border="1"> <tr><td>N</td><td>L</td><td>1</td><td>2</td><td>3</td><td>4</td></tr> <tr><td>5</td><td>3</td><td>not used</td><td>7</td><td>6</td><td></td></tr> </table>	N	L	1	2	3	4	5	3	not used	7	6							
N	L	1	2	3	4														
5	3	not used	7	6															
Horstmann Channel Plus H21, H27 Note: *Earth not required, Link L - 2 - 5	<table border="1"> <tr><td>E</td><td>N</td><td>L</td><td>1</td><td>2</td><td>3</td><td>4</td><td>5</td><td>6</td></tr> <tr><td>*</td><td>5</td><td>3</td><td>7</td><td>not used</td><td>6</td><td>not used</td><td></td><td></td></tr> </table>	E	N	L	1	2	3	4	5	6	*	5	3	7	not used	6	not used		
E	N	L	1	2	3	4	5	6											
*	5	3	7	not used	6	not used													
Siemens-Landis & Staefa RWB2, RWB9	<table border="1"> <tr><td>N</td><td>L</td><td>1</td><td>2</td><td>3</td><td>4</td></tr> <tr><td>5</td><td>3</td><td>not used</td><td>7</td><td>6</td><td></td></tr> </table>	N	L	1	2	3	4	5	3	not used	7	6							
N	L	1	2	3	4														
5	3	not used	7	6															
Potterton Myson EP 2002, EP 3002, EP 6002 Note: Link L - 5	<table border="1"> <tr><td>E</td><td>N</td><td>L</td><td>1</td><td>2</td><td>3</td><td>4</td><td>5</td></tr> <tr><td>⊕</td><td>5</td><td>3</td><td>not used</td><td>7</td><td>6</td><td></td><td></td></tr> </table>	E	N	L	1	2	3	4	5	⊕	5	3	not used	7	6				
E	N	L	1	2	3	4	5												
⊕	5	3	not used	7	6														
Sunvic Select 207	<table border="1"> <tr><td>N</td><td>L</td><td>1</td><td>2</td><td>3</td><td>4</td></tr> <tr><td>5</td><td>3</td><td>not used</td><td>7</td><td>6</td><td></td></tr> </table>	N	L	1	2	3	4	5	3	not used	7	6							
N	L	1	2	3	4														
5	3	not used	7	6															

Fig. I.20



Thermostatic radiator valves

The boiler has a built in automatic bypass valve making it ideal for use in systems with thermostatic radiator valves (no separate system bypass is required).

For optimum fuel economy it is recommended that where TRV's are used they are used in conjunction with a programmable room thermostat or separate timer and room thermostat to ensure complete boiler shut down when the heating demand is satisfied. (The radiator in the room containing the room thermostat should not be fitted with a TRV).

Frost protection

The boiler has an integral frost thermostat which is designed for protection of the boiler.

To protect remote or exposed parts of the heating system or property additional frost protection measures must be taken such as the installation of an external frost thermostat. This frost thermostat should be connected across the boiler terminals 3 and 4, in parallel with any external heating controls.

Circulating pump

The boiler incorporates a built in circulating pump that is fully prewired (no additional wiring is necessary). The pump incorporates an automatic overrun period after the boiler switches off.

Anti-cycling 'economiser' control

The boiler incorporates a built in anti-cycling control to ensure that energy wasteful short cycling of the boiler cannot occur. This control prevents the boiler from re-igniting for a preset period of 5 minutes after central heating operation (the hot water operation is unaffected by this control and hot water can be drawn at any time).

Note: To temporarily override the anti-cycling control turn the main boiler on/off switch to the off position „0“ and then back to the on position „1“ after a few seconds.

Automatic pump spin control (APS)

The boiler incorporates a built in control which will spin the built in circulating pump and operate the diverter valve (TURBOmax only) once in a 24 hour period. This control helps to prevent seizure when the boiler is not operated for a period of time. This control is not active when the power supply to the appliance is turned off.

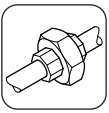

BOILER INSTALLATION SEQUENCE

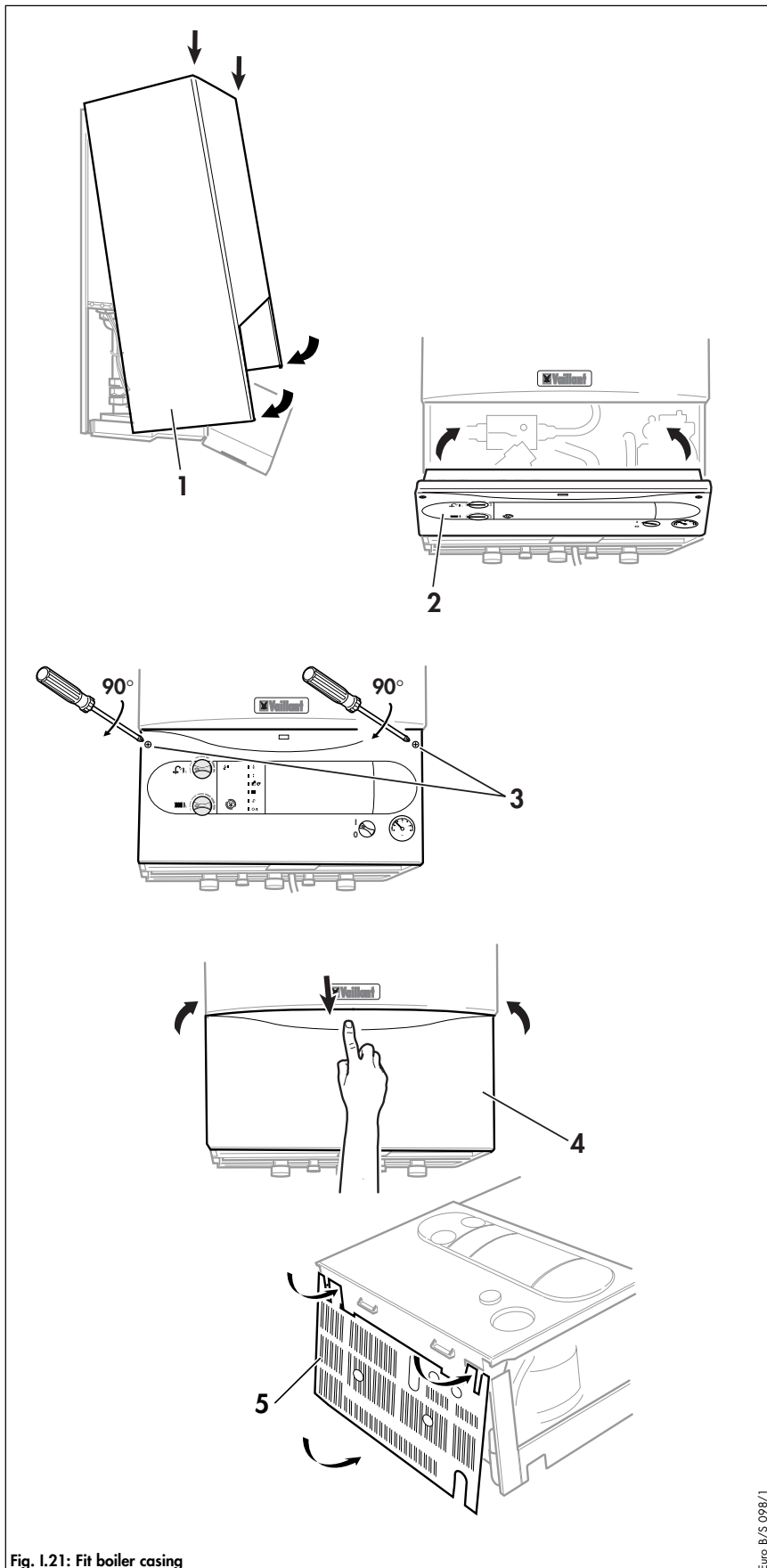

Fig. I.21: Fit boiler casing

Euro B/S.098/1

Fit boiler casing

- Carefully push case (1) onto the boiler such that the locating points either side at the top of the boiler engage. Push the casing onto the securing clips at the bottom of the boiler.
- Close control panel (2).
- Secure control panel by turning both securing fasteners (3) clockwise by 90°.
- Fit and close front door (4).
- Fit lower cover plate (5) using the screws supplied.



Preliminary electrical checks

Check the electrical installation by carrying out short circuit, earth continuity and resistance to earth tests and a check for correct polarity.

Gas supply

The complete gas installation including the gas meter must be inspected, tested for soundness and purged in accordance with BS 6891.

The gas supply to the boiler can be purged by slackening the gas service valve beneath the boiler. Ensure that there is adequate ventilation, extinguish all naked flames and do not smoke whilst purging.

After purging, the gas service valve connection must be retightened and tested for soundness. (The boiler itself does not require purging as this will be done by the automatic burner sequence control).

Cold water supply (TURBOmax Plus only)

Open all domestic hot water taps supplied by the boiler, turn on the mains water supply to the boiler and open the mains water isolating valve below the boiler.

Water will now flow through the boiler to the hot taps. Starting with the lowest tap supplied, turn the hot taps off one at a time until the hot water pipework is purged of air.

Check all hot and cold water pipework for leaks.



COMMISSIONING PART I

TURBOmax Plus

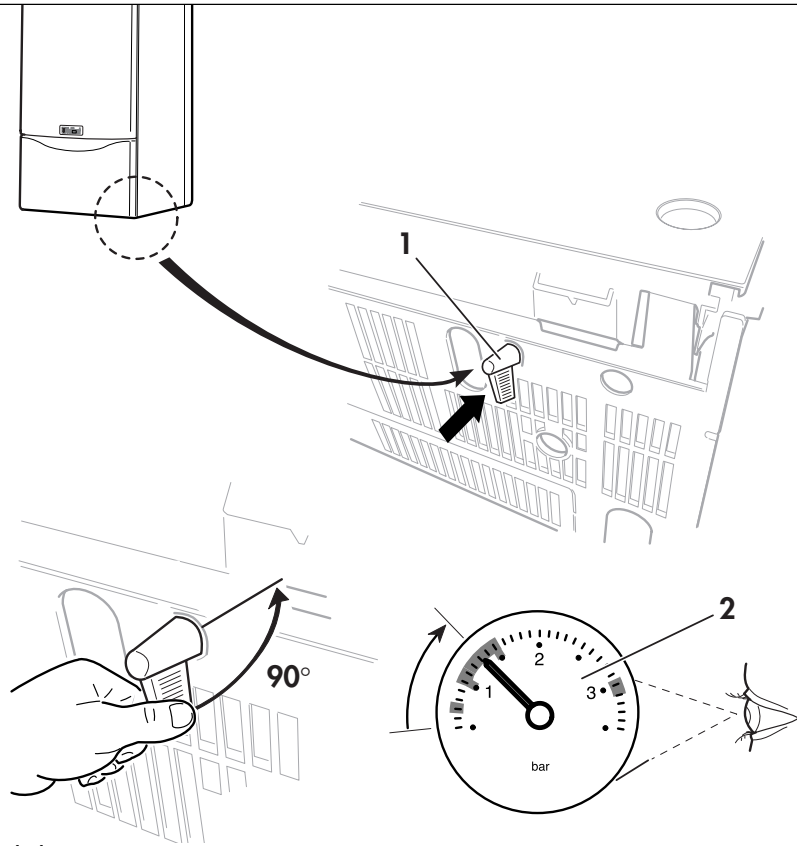

Fig. Com. 1: Filling TURBOmax Plus boiler

Eco-B/S 054/0



Filling the heating system (TURBOmax Plus)

Proceed as follows to fill the system:

- Open all radiator valves on the system.
- Check flexible filling loop is connected.
- Locate the filling valve handle (1) on the valve as shown.
- Open the valve slowly and fill the unit with water until the required amount has been added (2).
- Bleed the air from the radiators.
- The boiler is equipped with an automatic air release valve. To allow this to vent the boiler, the cap top must be slackened by 1 - 2 turns. (This cap must be left slackened during operation to ensure any residual air or system gases are released)

Initial system flush ("cold")

The whole of the heating system must be flushed out at least twice: once cold, and once hot as instructed later on page 53.

Open all radiator and heating valves and the boiler CH service valves and drain the heating system and boiler completely from the lowest points of the system via 1/2" BSP drain taps (opened full bore to remove any installation debris prior to lighting the boiler).

Refill the heating system.

Check the operation of the pressure relief valve by rotating the knob on the valve.

Now check the water pressure in the unit again (and add more water if necessary).

Close the filling valve (1) and disconnect the temporary connection.



COMMISSIONING PART I

Filling the heating system (THERMOcompact)

The boiler and the heating system should be filled using a filling method as described on page 16.

- Ensure that the boiler CH service valves are open.
- Partially open the filling valve and allow water to enter the system. Starting with the lowest radiator, open the radiator air release until water (clear of bubbles) is emitted.
- Repeat this at all radiators until the complete system is full, all air locks have been cleared and the boiler pressure gauge reads 1.5 bar. Release any air from the pump by slackening the centre screw.
- The boiler is equipped with an automatic air release valve. To allow this to vent the boiler, the cap on the top must be slackened by 1 - 2 turns. (This cap must be left slackened during boiler operation to ensure any residual air or system gases are released).
- Check the heating system and boiler connections are sound.

Initial system flush ("cold")

The whole of the heating system must be flushed out at least twice: once cold, and once hot as instructed later on page 53.

Open all radiator and heating valves and the boiler CH service valves and drain the heating system and boiler completely from the lowest points of the system via 1/2" BSP drain taps (opened full bore to remove any installation debris prior to lighting the boiler).

Refill the heating system.

Check the operation of the pressure relief valve by rotating the knob on the valve.

Now check the water pressure in the unit again (and add more water if necessary).





GAS SUPPLY ADJUSTMENTS (COMMISSIONING PART II)

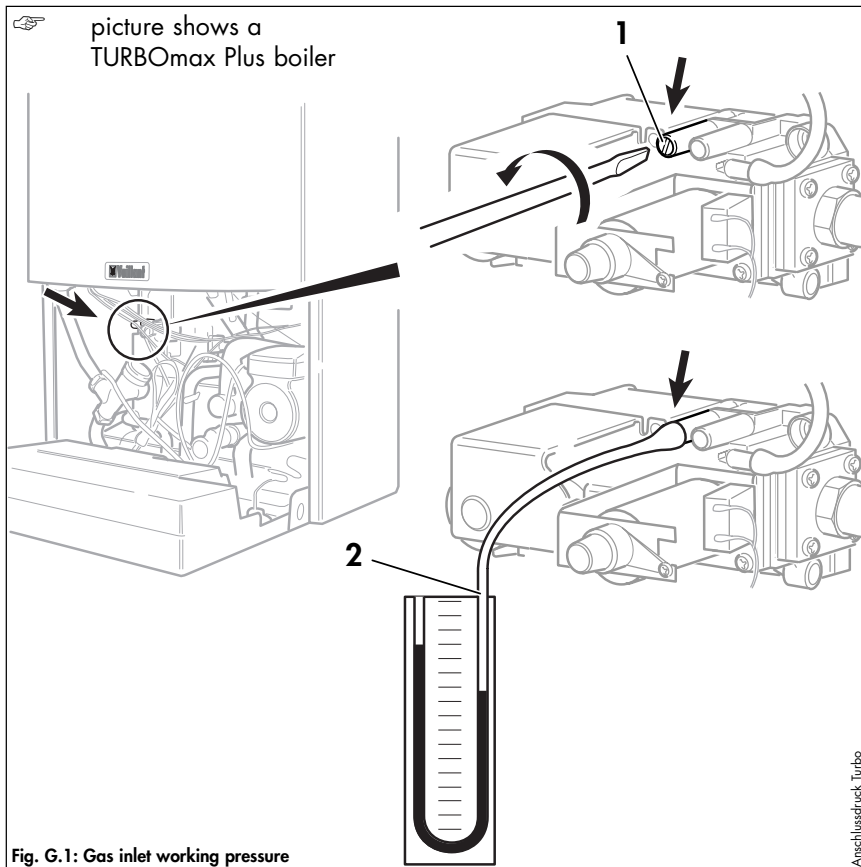

Gas inlet working pressure

To check the gas inlet working pressure:

- Lower the front panel of the boiler.
- Lower the control panel.
- Slacken the sealing screw (1) located at measuring point „P.IN“.
- Attach U-gauge to the inlet test point on the gas valve (2).
- Ensure that the gas service valve is open.
- Turn off the boiler at the main ON/OFF control.
- Press and hold the „+“ button, while pressing the button turn the main ON/OFF control to the „1“ ON position.
- Continue holding „+“ button until display alternates between „P1“ and „P2“. Release „+“ button.
- Press „+“ button until „P1“ (full gas rate) is shown in display.
- Press „i“ button to operate boiler at full gas rate.
- Check that the U-gauge is reading in the range between 18 and 20 mbar. If the pressure is not within this range this should be investigated before continuing with the commissioning procedure. Lower pressures than this range are indicative of an incorrectly sized or partially blocked gas supply.
- Switch off the boiler at the main ON/OFF control.
- Remove U-gauge, tighten test point sealing screw (1).
- Test for soundness.
- Record appliance working gas inlet pressure (mbar) in the Benchmark Installation, Commissioning and Service Log Book.

GAS SUPPLY ADJUSTMENTS (COMMISSIONING PART II)



U-Gauge connection points for Natural gas

picture shows a TURBOmax Plus boiler

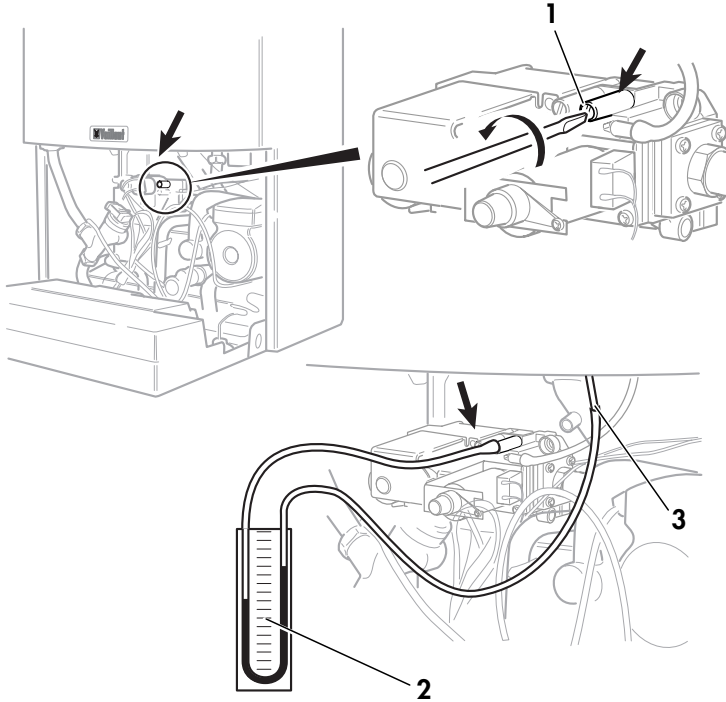

Connection for LPG

picture shows a TURBOmax Plus boiler

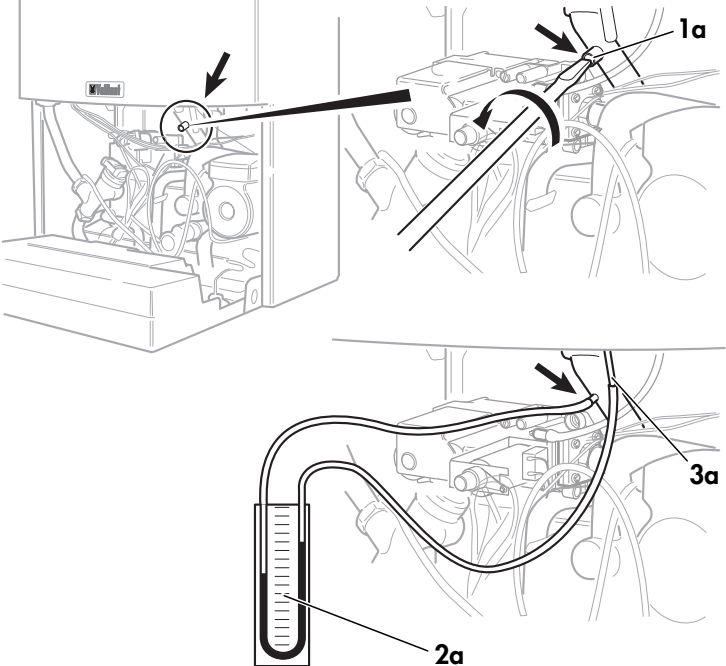

Main burner pressure

- The burner pressure on this appliance has been factory set and does not require adjustment. To check the main burner pressure connect the U-Gauge as follows depending on the gas type.

For natural gas appliances:

Slacken the sealing screw (1) at test point on the gas valve and attach one arm of a U-gauge (2) to the test point. Remove plastic sealing plug and connect the other arm to the combustion chamber sensing tube (3).

For LPG appliances:

Slacken the sealing screw (1a) at test point on the burner inlet gas pipe and attach one arm of a U-gauge (2a) to the test point.

Remove plastic sealing plug and connect the other arm to the combustion chamber sensing tube (3a).

- Turn off the boiler at the main ON/OFF control.
- Press and hold the „+“ button, while pressing the button turn the main ON/OFF control to the „1“ ON position.
- Continue holding „+“ button until display alternates between „P1“ and „P2“. Release „+“ button.
- Press „+“ button until „P1“ is shown in the display. „P1“ indicates the maximum gas rate and „P2“ indicates the ignition rate.
- Press „i“ button to operate boiler at maximum gas rate.

Check that the burner pressure is correct as shown in table G3 for the appropriate boiler.

To cancel selected „P1“ or „P2“ mode press the „i“ and „+“ buttons simultaneously.

TURBOmax Plus only

Measure the domestic hot water burner operating pressure (mbar), the heat input (kW), the inlet/outlet domestic hot water temperatures (°C) and flow rate (l/min) by fully opening a hot water tap and record details in the boiler logbook.

THERMOcompact only

Record the heat input in the boiler logbook.

After completion of all tests tighten sealing screw, replace the sealing plug and check all test points for soundness (1/1a).

Fig. G.2: Connection of U-gauge



GAS SUPPLY ADJUSTMENTS (COMMISSIONING PART II)



This illustration shows the U-tube pressure gauge connected to a system configured to run on natural gas. When connecting the U-tube pressure gauge to a system running on LPG, please refer to Fig. G.2 on page 45.

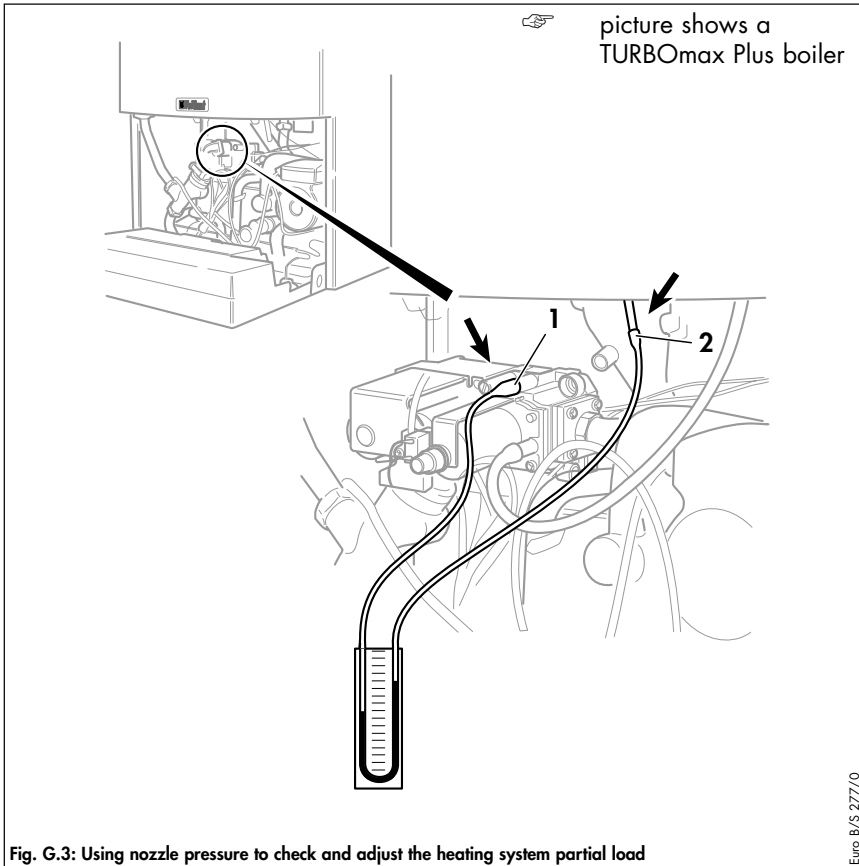

Adjusting the central heating output (range rating)

The boilers are fully modulating for central heating, and it is therefore not necessary to range rate the boiler. However, if desired, it is possible to range rate the boiler, as follows:

- Connect the U-gauge to check burner pressure.
- Use Table G.3 on page 48 to determine the central heating output required.
- Note the burner pressure setting.
- Turn on the central heating.
- Ensure that any thermostatic radiator valves are open and set to high.
- Simultaneously press and release the „+“ and „-“ buttons to activate burner pressure mode.
- The boiler will light at the factory set nominal gas rate.

DO NOT open any hot water tap while carrying out this procedure (TURBOmax Plus only).

- Check that the U-gauge reading corresponds to the maximum burner pressure as detailed on the table on page 48.
- Identify required range rating setting and note main burner pressure in mbar for that output.
- Adjust central heating output range as shown on page 47.

Note: Following adjustment of the central heating output, the new output can be checked using the gas rate table as detailed on page 49.

- Record central heating operating pressure in the Benchmark Log Book along with the heat input (kW) and temperature difference between flow and return.

GAS SUPPLY ADJUSTMENTS (COMMISSIONING PART II)

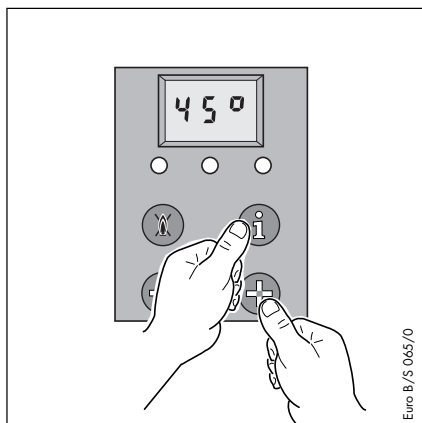
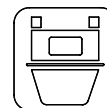

- 1** Simultaneously press the „i” and „+” buttons keys.

Euro B/S 0665/0

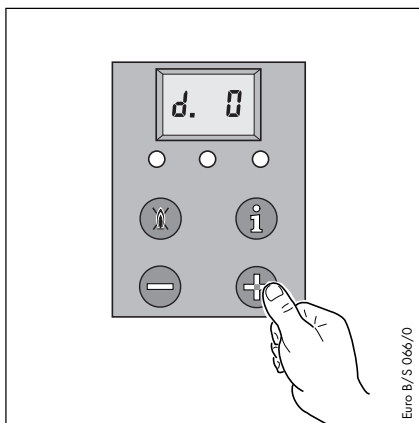

- 2** Keep the „+” button pressed until „d.0” is displayed.

(The display runs from „d.0” to „d.99” before restarting again at „d.0”.)

Euro B/S 0666/0

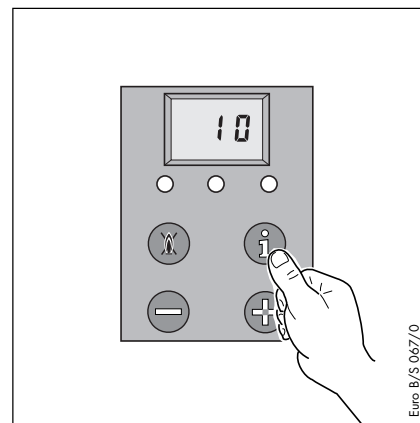

- 3** Press the „i” button and a value between 1 and 15 will be displayed.

Euro B/S 0667/0

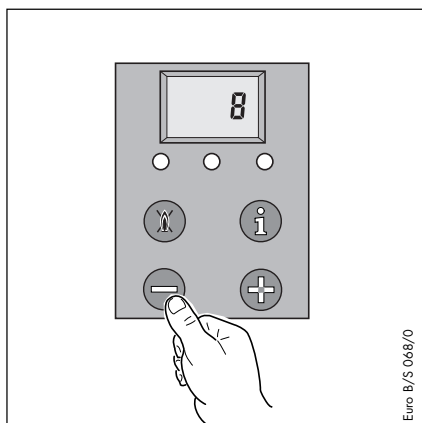

- 4** Use the „+” or „-” buttons to increase or decrease the value. Observe the U-gauge as the button is pushed and stop pushing when the required main burner pressure has been achieved.

Euro B/S 0668/0

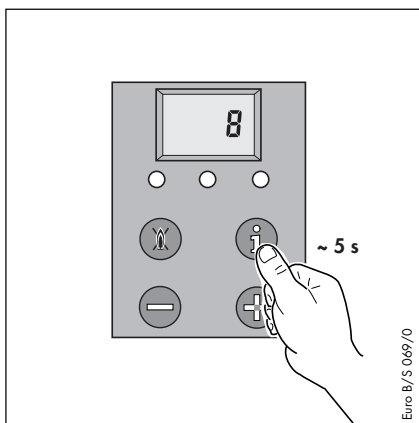

- 5** After setting, press and hold the „i” button for five seconds - or until the display stops flashing. The new setting value is now memorised. The new main burner pressure can now be checked.

If the new output is not correct repeat steps 3 to 5.

Euro B/S 0669/0

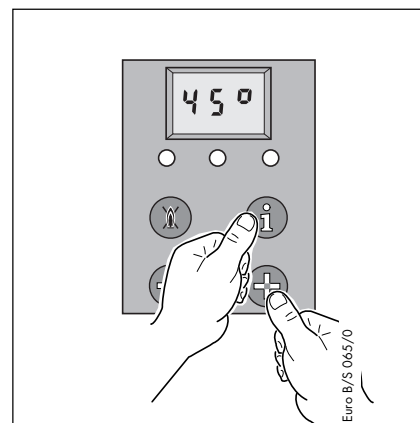

- 6** To return to normal mode, press the „i” and „+” buttons simultaneously. The adjustment mode is also cancelled if no button is pushed for a period of four minutes.

Euro B/S 0665/0



GAS SUPPLY ADJUSTMENTS (COMMISSIONING PART II)

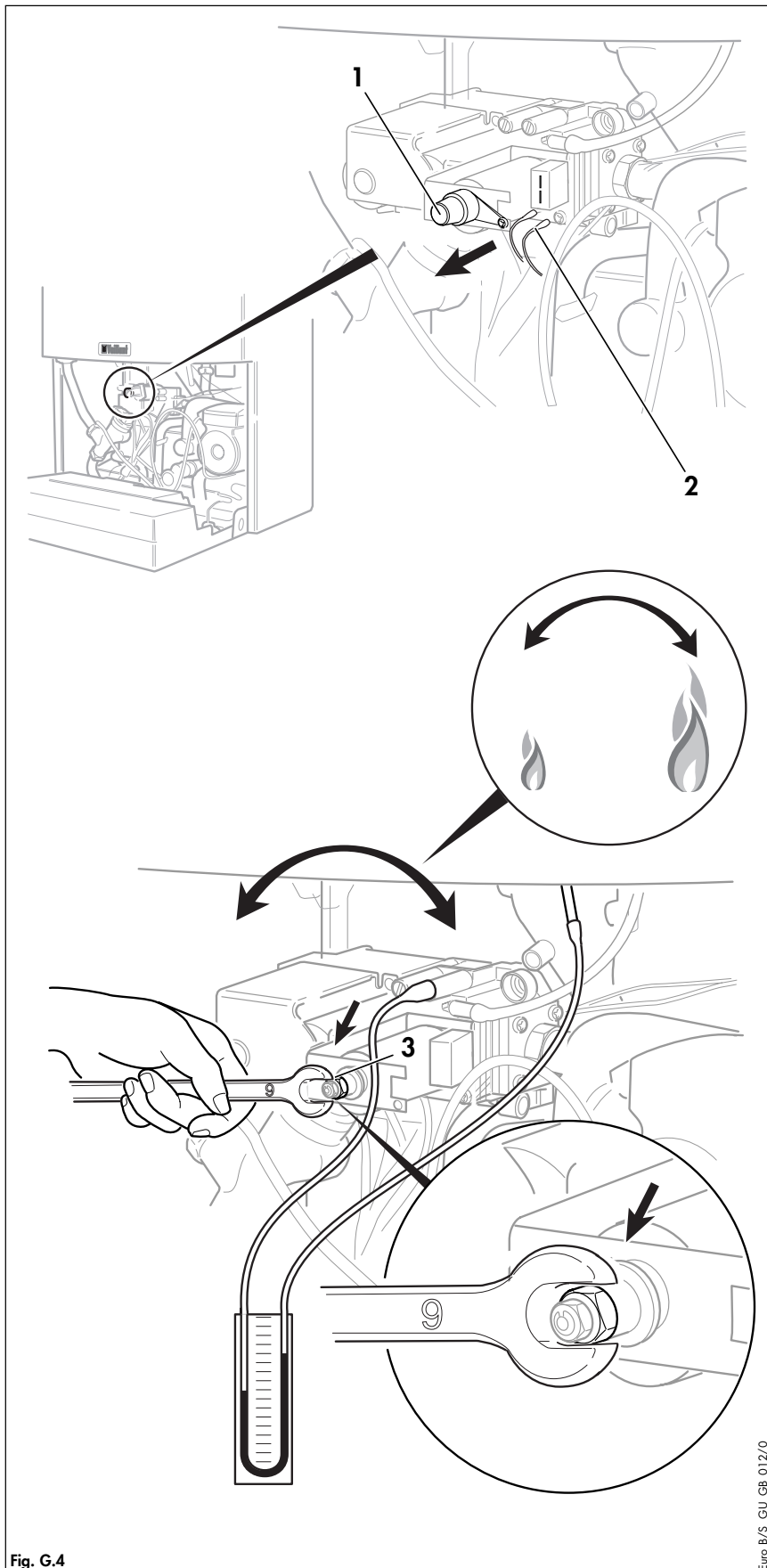

Fig. G.4

Euro B/S CU_GB_012/0

Adjusting the ignition rate

- Undo screw and remove the cap (1).
- **TURBOmax only:** Disconnect the modulating coil wires (2) from the gas valve, set the DHW temperature control to maximum and fire the boiler at full rate by fully opening a hot water tap.
- **THERMOcompact only:**
 - Turn off the boiler at the main ON/OFF control.
 - Press and hold the „+“ button, while pressing the button turn the main ON/OFF control to the „1“ ON position.
 - Continue holding „+“ button until display alternates between „P1“ and „P2“. Release „+“ button.
 - Press „+“ button until „P2“ (ignition rate) is shown in display.
 - Press „i“ button to operate boiler at full gas rate.
- Using a 9 mm spanner turn the outer hexagonal nut (3) to adjust the ignition rate.
 - Turn the nut (3) clockwise to increase the ignition rate
 - Turn the nut (3) anticlockwise to decrease the ignition rate
- Adjust the burner pressure until it matches the ignition rate as detailed on page 22.
- **TURBOmax only:** Turn off the hot water tap and reconnect the wires to the modulating regulator.
- **THERMOcompact only:** To cancel selected „P1“ or „P2“ mode press the „i“ and „+“ buttons simultaneously.

GAS SUPPLY ADJUSTMENTS (COMMISSIONING PART II)

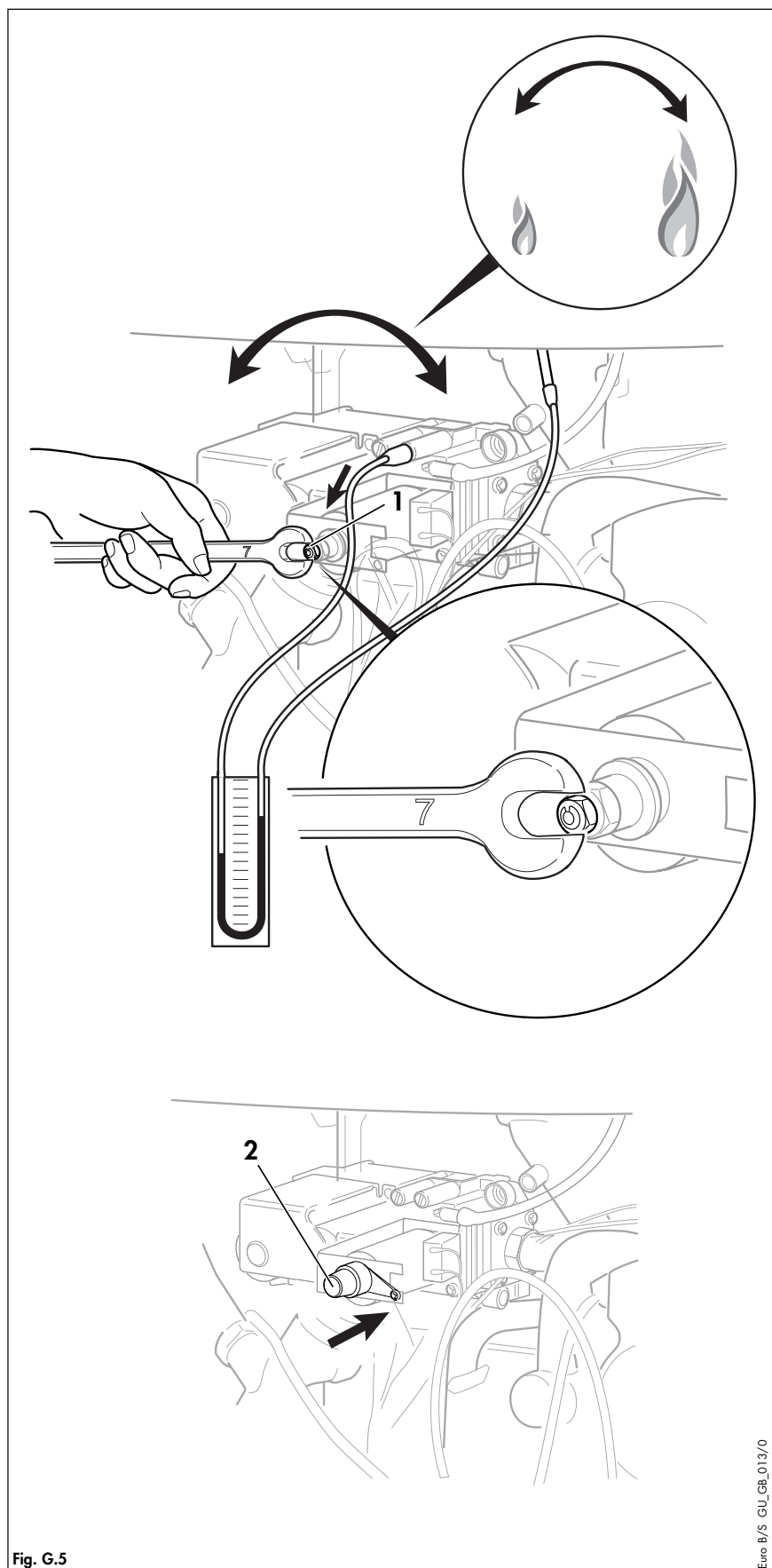
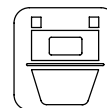

Adjusting to the maximum heat load (nominal load)

- **TURBOmax only:** Set the DHW temperature control to maximum and fire the boiler at full rate by fully opening a hot water tap.
- **THERMOcompact only:**
 - Turn off the boiler at the main ON/OFF control.
 - Press and hold the „+“ button, while pressing the button turn the main ON/OFF control to the „I“ ON position.
 - Continue holding „+“ button until display alternates between „P1“ and „P2“. Release „+“ button.
 - Press „+“ button until „P1“ (full gas rate) is shown in display.
 - Press „i“ button to operate boiler at full gas rate.
- Using a 7 mm spanner turn the inner hexagonal nut (1) to adjust the burner operating pressure.
 - Turn the nut (1) clockwise to increase the nominal load
 - Turn the nut (1) anticlockwise to decrease the nominal load
- Adjust the burner pressure until it matches the maximum output as detailed on page 22.
- Now turn the 7 mm hexagonal nut (1) anticlockwise until the burner pressure drops by approx. 0.3 - 0.4 mbar.

Nominal load is now correctly adjusted.

- Refit the plastic cap (2).



The plastic cap (2) must be fitted for the gas valve assembly to function correctly.

- **TURBOmax only:** Turn off the hot water tap.
- **THERMOcompact only:** To cancel selected „P1“ or „P2“ mode press the „i“ and „+“ buttons simultaneously.

Fig. G.5

Euro B/S GULGB_01/3/0



GAS SUPPLY ADJUSTMENTS (COMMISSIONING PART II)

Burner pressure and gas rate

Burner Pressure THERMOcompact 615/2 E									
Delivered gas	Output [kW]	Ignition rate	6.5	8.0	10.0	12.0	14.0	15.0	
Natural gas 2H Main burner jet mark ²⁾ 7/120	Burner pressure ¹⁾ [mbar]								
	for G20	2.3	2.3	3.3	5.0	7.0	9.3	10.5	
LPG 3+ Main burner jet mark ²⁾ 7/072	Burner pressure ¹⁾ [mbar]								
	for G30	5.8	5.8	8.1	11.9	16.3	21.5	24.3	
	for G31	7.5	7.5	10.5	15.4	21.2	27.9	31.6	

Burner Pressure THERMOcompact 620/2 E										
Delivered gas	Output [kW]	Ignition rate	7.7	8.0	10.0	12.0	14.0	16.0	18.0	20.0
Natural gas 2H Main burner jet mark ²⁾ 7/120	Burner pressure ¹⁾ [mbar]									
	for G20	1.8	1.8	1.9	2.8	3.8	5.1	6.4	7.9	9.6
LPG 3+ Main burner jet mark ²⁾ 7/072	Burner pressure ¹⁾ [mbar]									
	for G30	4.1	4.1	4.3	6.2	8.5	11.3	14.3	17.7	21.4
	for G31	5.4	5.4	5.6	8.1	11.1	14.7	18.6	22.9	27.6

Burner Pressure THERMOcompact 624/2 E, TURBOmax Plus 824/2 E											
Delivered gas	Output [kW]	Ignition rate	8.9	10.0	12.0	14.0	16.0	18.0	20.0	22.0	24.0
Natural gas 2H Main burner jet mark ²⁾ 7/120	Burner pressure ¹⁾ [mbar]										
	for G20	1.9	1.9	2.1	2.9	3.7	4.7	5.8	6.7	8.4	9.8
LPG 3+ Main burner jet mark ²⁾ 7/072	Burner pressure ¹⁾ [mbar]										
	for G30	4.1	4.1	4.7	6.4	8.4	10.8	13.4	16.5	20.3	24.0
	for G31	5.4	5.4	6.1	8.3	10.9	14.0	17.4	21.4	26.4	31.7

Burner Pressure THERMOcompact 628/2 E, TURBOmax Plus 828/2 E												
Delivered gas	Output [kW]	Ignition rate	10.4	12.0	14.0	16.0	18.0	20.0	22.0	24.0	26.0	28.0
Natural gas 2H Main burner jet mark ²⁾ 7/120	Burner pressure ¹⁾ [mbar]											
	for G20	1.8	1.8	2.2	2.9	3.7	4.7	5.6	6.8	8.0	9.4	10.8
LPG 3+ Main burner jet mark ²⁾ 7/072	Burner pressure ¹⁾ [mbar]											
	for G30	4.2	4.2	5.1	6.6	8.2	10.4	12.8	17.4	18.2	21.3	24.6
	for G31	5.5	5.5	6.7	8.7	11.1	13.7	16.8	22.8	23.8	27.8	32.0

Table G.3: Burner pressure

¹⁾ 15 °C, 1013 mbar, dry
²⁾ The nozzles are stamped with the mark shown in this table. The marking corresponds to the nozzle hole diameter multiplied by 100.
³⁾ Ignition rate

GAS SUPPLY ADJUSTMENTS (COMMISSIONING PART II)



Gas Rate THERMOcompact 615/2 E							
Delivered gas	Output [kW]	6.5	8.0	10.0	12.0	14.0	15.0
Natural gas 2H Main burner jet mark ²⁾ 7/120	Gas Rate ¹⁾ [m ³ /h]						
	for G20	0.8	1.0	1.3	1.4	1.7	1.7

Gas Rate THERMOcompact 620/2 E											
Delivered gas	Output [kW]			7.7	8.0	10.0	12.0	14.0	16.0	18.0	20.0
Natural gas 2H Main burner jet mark ²⁾ 7/120	Gas Rate ¹⁾ [m ³ /h]										
	per G20			0.9	1.0	1.2	1.4	1.7	1.9	2.1	2.3

Gas Rate THERMOcompact 624/2 E, TURBOmax Plus 824/2 E											
Delivered gas	Output [kW]	8.9	10.0	12.0	14.0	16.0	18.0	20.0	22.0	24.0	
Natural gas 2H Main burner jet mark ²⁾ 7/120	Gas Rate ¹⁾ [m ³ /h]										
	for G20	1.1	1.2	1.4	1.7	1.9	2.1	2.4	2.6	2.8	

Gas Rate THERMOcompact 628/2 E, TURBOmax Plus 828/2 E											
Delivered gas	Output [kW]	10.4	12.0	14.0	16.0	18.0	20.0	22.0	24.0	26.0	28.0
Natural gas 2H Main burner jet mark ²⁾ 7/120	Gas Rate ¹⁾ [m ³ /h]										
	per G20	1.3	1.5	1.7	1.9	2.1	2.4	2.6	2.8	3.1	3.3

Table G.4: Gas flow rate

¹⁾ 15 °C, 1013 mbar, dry

²⁾ The nozzles are stamped with the mark shown in this table. The marking corresponds to the nozzle hole diameter multiplied by 100.

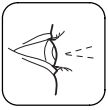

FUNCTIONAL CHECKS (COMMISSIONING PART III)

I
O

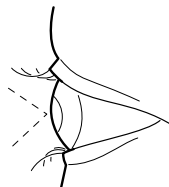
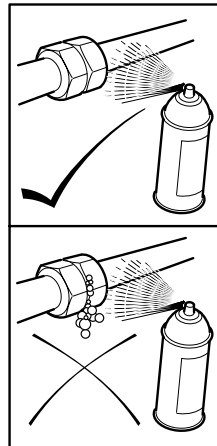
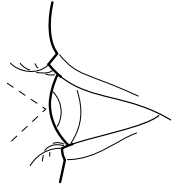
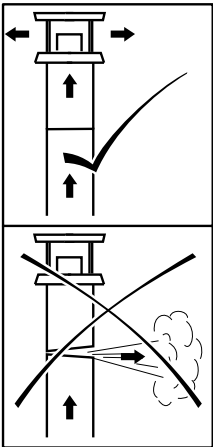
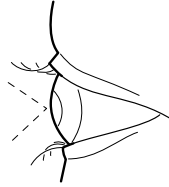
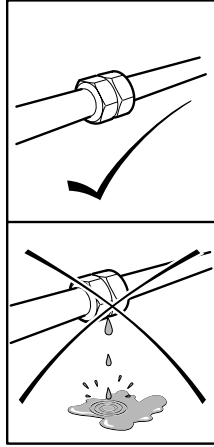
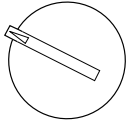

Functional checks

Procedure

Once the unit has been installed and the gas supply has been checked, operate the system to ensure that it is working correctly.

- Operate the system, following the operating instructions supplied with the boiler.
- Check the system for water leaks and escaping gas.
- Check that the flue has been correctly installed, according to the fitting instructions supplied with the flue assembly.
- Check the burner for correct ignition and flame picture.
- **TURBOmax Plus only:** Check the hot water system for correct operation.
- Check the heating system for correct operation.

Fig. F.1: Test for correct functioning

Euro B/S 058/O

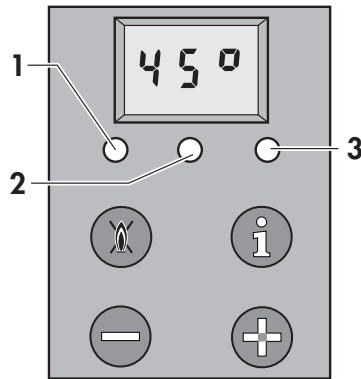
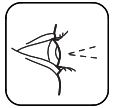

Fig. F.2: Functional check TURBOmax Plus

Euro B/S 071/0

Functional check of operation (TURBOmax Plus only)

This boiler is fitted with indicator lights to display the operating status of the boiler. The status of the indicators in normal operation will be as follows.

Boiler in stand by mode

- Red lock out indicator (1) OFF.
- Yellow flame indicator (2) OFF.
- Green warmstart indicator (3).
 - ON – Warmstart ON
 - OFF – Warmstart OFF

Hot water operation

- Fully open hot water tap.

If boiler is operating correctly, the status of the indicators will be as follows:

- Red lock out indicator (1) OFF.
- Yellow flame indicator (2) ON (Flame indicator).
- Green warmstart indicator (3) FLASHING (hot water is being drawn from the system).

Central Heating operation

- Operate the heating system.

If boiler is operating correctly, the status of the indicators will be as follows:

- Red lock out indicator (1) OFF.
- Yellow flame indicator (2) ON (burner active).
- Green warmstart indicator (3) ON, OFF or FLASHING (see above).

The LCD display indicates the flow temperature (in °C) of the boiler in normal operation.

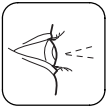

FUNCTIONAL CHECKS (COMMISSIONING PART III)

THERMOcompact

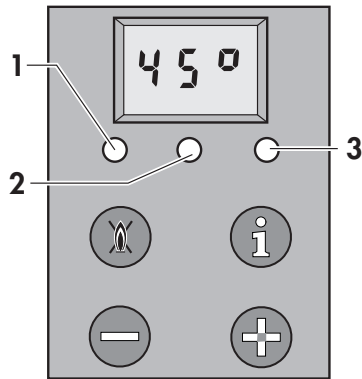

Fig. F.3: Functional check THERMOcompact

Euro B/S.071/0

Functional check of operation (THERMOcompact only)

This boiler is fitted with indicator lights to display the operating status of the boiler. The status of the indicators in normal operation will be as follows.

Boiler in stand by mode

- Red lock out indicator (1) OFF.
- Yellow flame indicator (2) OFF.
- Green indicator (3) has no function.

Central Heating/hot water operation

- Operate the heating/hot water system.

If boiler is operating correctly, the status of the indicators will be as follows:

- Red lock out indicator (1) OFF.
- Yellow flame indicator (2) ON (burner active).
- Green indicator (3) OFF.

The LCD display indicates the flow temperature (in °C) of the boiler in normal operation.

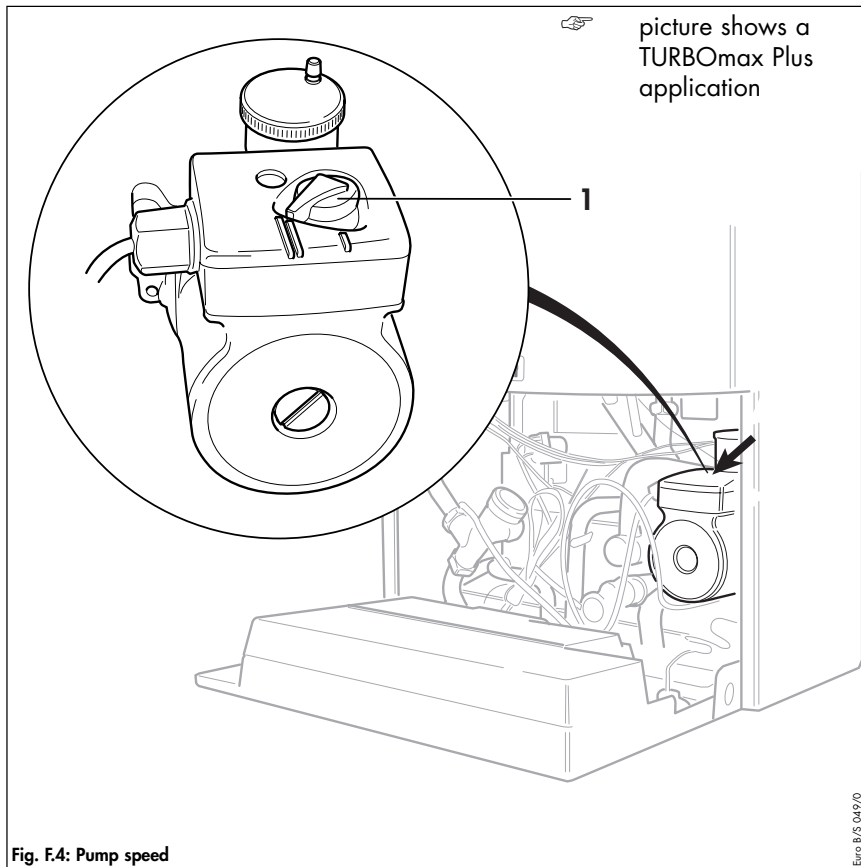

Adjusting pump speed

The unit is fitted with a two-speed pump.
The pump is delivered with the switch (1) set to position II.

Important note:

The boiler should only be operated at pump setting II because the heating capacity for hot water is reduced when operated at pump setting I!

It is possible, however, to change the pump setting from Level II to Level I manually when there is noise coming from the heating system.

Final system flush („HOT“)

Turn on the boiler for central heating and allow the boiler and system to reach operating temperature. Check that the heating system is watertight. Turn the boiler off and rapidly drain both boiler and system while still hot:

Refill the system and release all air. Release water from the system until the system design pressure of 1.0 bar is attained.

(The actual reading on the pressure gauge should ideally be 0.5 bar plus an additional pressure corresponding to the highest point of the system above the base of the boiler - 10 m head equals an additional 1 bar reading on the pressure gauge. The minimum pressure should not be less than 1 bar in any installation.)

If the system is to be treated with an inhibitor it should be applied at this stage. Sentinel X100 is suitable for this purpose and it should be applied in accordance with the manufacturers instructions.

Further information can be obtained from Sentinel, Betz Dearborn Ltd., Tel: 0151 4951861.

Disconnect the temporary filling connection.

Refit the boiler casing.

Attach the bottom cover to the boiler by securing with the four screws provided. It may be necessary to apapt the bottom cover by removing the easy break sections.

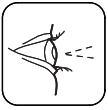

FUNCTIONAL CHECKS (COMMISSIONING PART III)

Handing over to the user

Set the maximum radiator temperature control to the desired setting.

Set the maximum hot water temperature control to the desired setting.

Instruct the user in the safe and efficient operation of the boiler, in particular the function of

- The boiler on/off control
- The maximum radiator temperature control
- The maximum hot water temperature control (TURBOmax Plus only)
- The pressure gauge

Show the user how to operate any external controls.

Explain to the user the importance of having the boiler regularly serviced by a competent servicing company. To ensure regular servicing, it is strongly recommended that arrangements are made for a Maintenance Agreement. Please contact Vaillant Service Solutions (0870 6060 777) for further details.

Ensure the boiler log book is fully completed and leave with the end user. Failure to install and commission this appliance to the manufacturers instructions may invalidate the warranty (Note: This does not affect your statutory rights).

Leave the user instructions and the boiler log book in the clips provided in the front panel of the boiler.

Leave the installation and servicing instructions with the user.

Note: Fit the Benchmark Log Book under the users instructions.



Initial Inspection

To ensure the continued safe and efficient operation of the boiler it is recommended that it is checked and serviced as necessary at regular intervals. The frequency of servicing will depend upon the particular installation conditions and usage, but in general once per year should be adequate. It is the law that all servicing work is carried out by a competent person (Corgi registered).

Important: Before starting any maintenance work:

- Isolate the mains electricity supply by disconnecting the plug at the socket outlet (if there is only an isolating switch remove the fuse from the switch).
- Turn OFF the gas supply at the gas service valve fitted to the boiler.
- Always test for gas soundness and always carry out functional checks after any service work and after exchanging any gas carrying component.
- Always check earth continuity, polarity and resistance to earth with a multimeter after any service work and after exchanging any electrical component.

Note: The boiler is fitted with a combustion analysis test point. A suitable combustion analyser can be connected to this point to establish the combustion performance of the boiler.

Before commencing any servicing or maintenance work, carry out an initial inspection of the system as follows:

- Inspect the flue, pipework and electrical connections for indications of damage or deterioration.
- Inspect the air supply and ventilation arrangements of the installation.
- Check the heating and water system, in particular the condition of radiator valves, evidence of leakage from the heating system and dripping hot water taps.

Functional check of boiler operation

- Carry out a functional check of the boiler operation as previously detailed.
- Remove the appliance casing as detailed on page 22 and operate the boiler by fully opening a hot water tap. Inspect the burner operation through the viewing window. Check that the flames are evenly covering the surface of the burner. Inspect for signs of excessive flame lift or sooting.

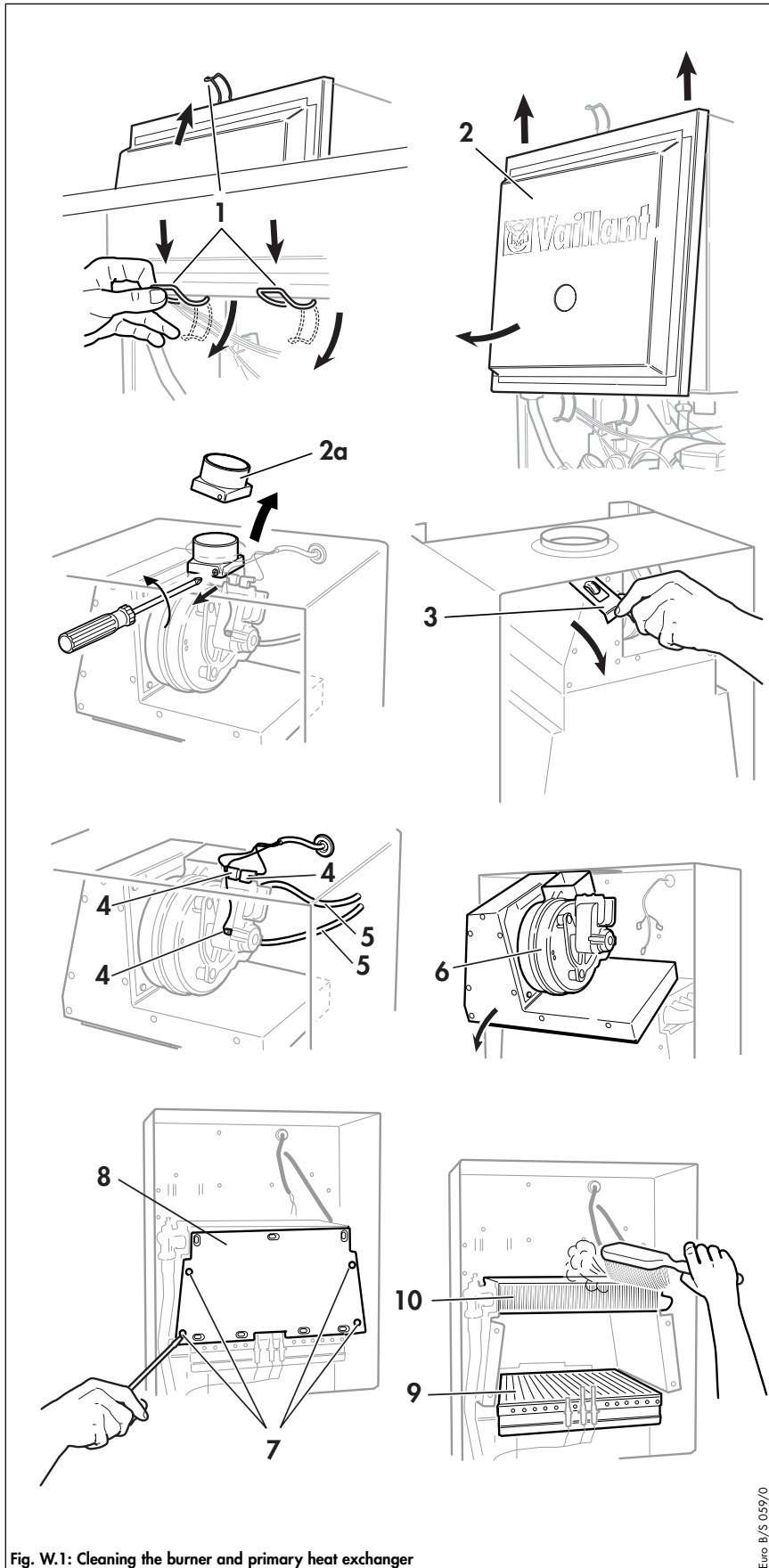

Fig. W.1: Cleaning the burner and primary heat exchanger

Eric B/S 03970

Cleaning the burner and primary heat exchanger

- Turn off the boiler.
- Isolate the electrical supply to the boiler.
- Remove the boiler case as described on page 22.
- Turn off the gas service valve.
- Turn off the boiler CH service valves.
- Turn off the cold water inlet service valve.
- Release the three clamps (1), remove the combustion chamber cover (2) and then remove the flue gas connector (2a) on the fan.
- Remove the retaining spring (3).
- Pull the three cables (4) and two tubes (5) from the fan assembly.
- Remove the fan assembly (6).
- Remove the four screws (7) and detach the front cover panel from the combustion chamber (8).
- Check the burner (9) and heat exchanger fins (10) and remove any loose deposits with a soft brush.
- Reassemble in reverse order.

Check central heating expansion vessel.

Note: It is not necessary to carry out this check every year – a check every three years should be sufficient.

- Release the system water pressure from the boiler.
- Remove valve cap from expansion vessel charge point.
- Check that the internal charge pressure of expansion vessel is between 0.7 - 0.9 bar. If pressure is lower than this the vessel should be re-pressurised using an air pump.
- Refit valve cap.
- Open central heating service valves and re-pressurise the boiler and heating system if necessary.
- Open the gas service valve.
- Turn on the mains power supply.
- Operate the boiler and carry out soundness, safety and function checks.
- Complete the service interval record section in the log book and leave with the user.

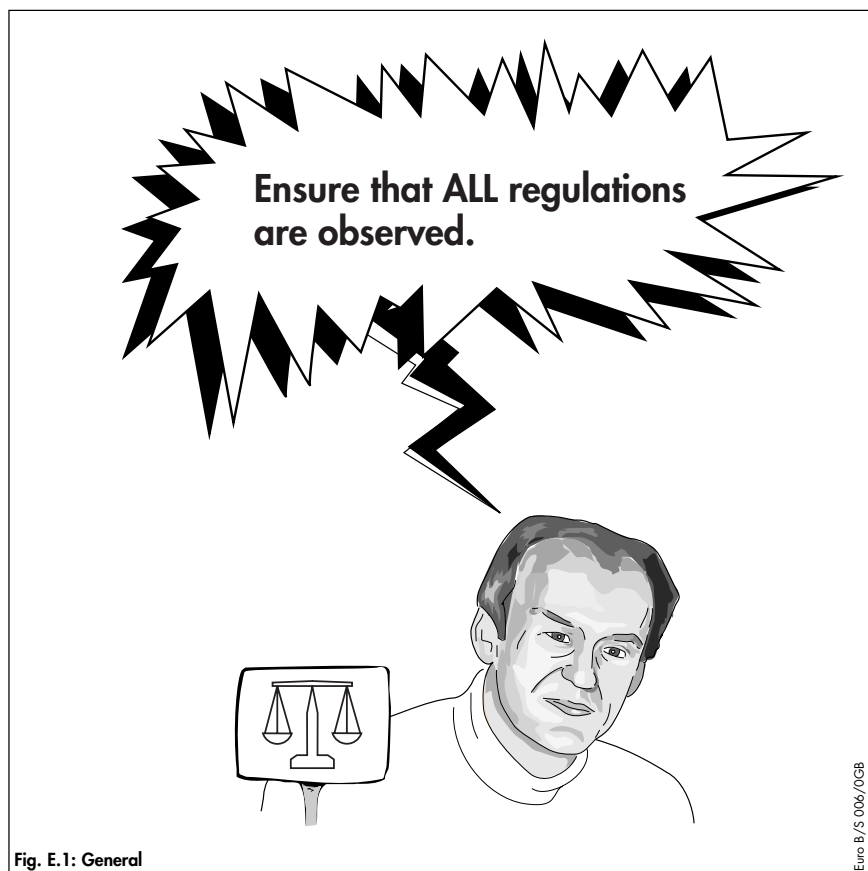
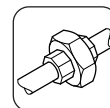

Fig. E.1: General

Euro B/S 006/0GB



After installing replacement parts, recommission and check boiler function as described in commissioning section.

Safety instructions



The following safety instructions are to be followed when installing replacement parts!

Important:

Before starting any maintenance work:

- Isolate the mains electricity supply by disconnecting the plug at the socket outlet (if there is only an isolating switch remove the fuse from the switch).
- Turn off the gas supply at the gas service valve fitted to the boiler.
- When removing any water carrying components ensure that water is kept away from all electrical components.
- Always use new seals and O-rings when replacing parts.
- Always test for gas soundness and always carry out functional checks after any service work and after exchanging any gas carrying component.
- Always check earth continuity, polarity and resistance to earth with a multimeter after any service work and after exchanging any electrical component.

Initial preparation

- Turn off the boiler.
- Isolate the electrical supply to the boiler.
- Remove boiler bottom cover by undoing the four retaining screws.
- Turn off the gas service valve.
- Turn off the boiler CH service valves.
- Turn off the cold water inlet service valve (TURBOmax Plus only).
- Open control panel cover.
- Lower electronic control box by turning securing screws 90° and lowering fascia panel.
- Remove front case by easing forward at bottom front edge and gently lifting off.
- Release central heating water pressure by draining the boiler from the drain points provided. (This needs only to be carried out when detailed in these instructions).

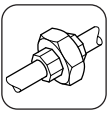

PARTS REPLACEMENT

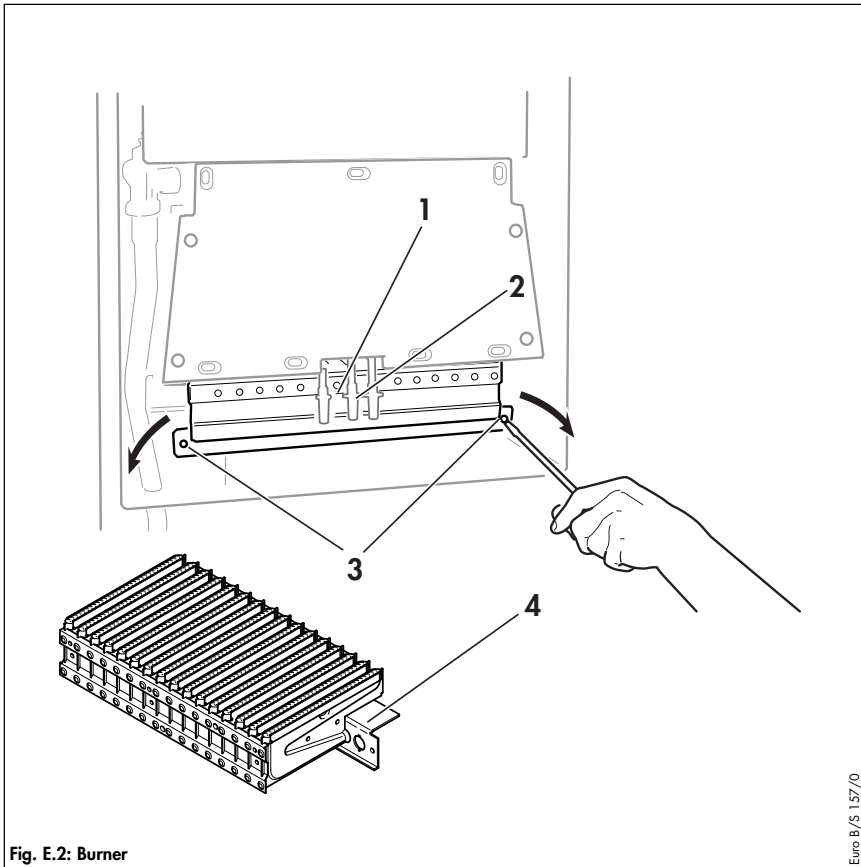

Burner

- Refer to the important information and initial preparation on page 59.
- Remove combustion chamber cover by unclipping the three clamps.
- Disconnect the ignition and flame sensing leads.
- Remove electrode bracket supporting screw (1) and then remove the electrodes (2).
- Remove two screws (3) and pull burner (4) forwards to remove.
- Reassemble in reverse order.

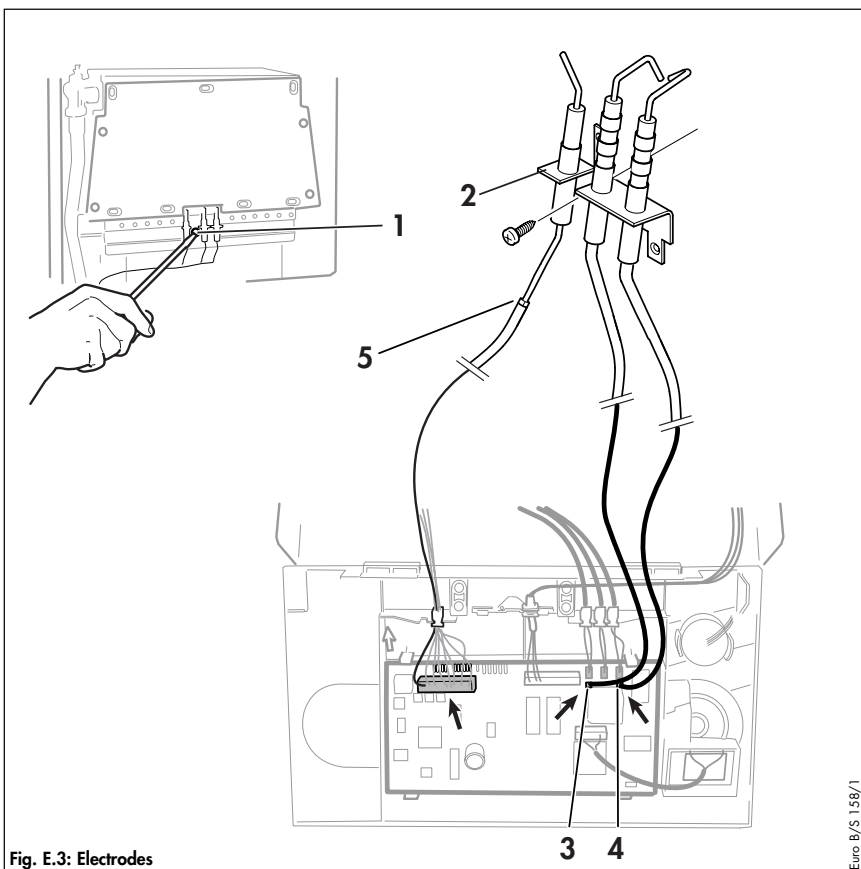

Electrodes

- Refer to the important information and initial preparation on page 59.
- Remove combustion chamber cover by unclipping the three clamps.
- Unclip the terminal box cover.
- Disconnect both HT leads (3, 4) from the electronic board.
- Pull off flame sensor HT lead (5).
- Remove electrodes (2) by removing support screw (1).
- Reassemble by following these instructions in reverse order.

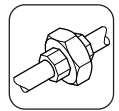

Fan

- Refer to the important information and initial preparation on page 59.
- Remove combustion chamber cover by unclipping the three clamps (1).
- Remove the screw (3) and push the flue connector (4) upwards until it clears the fan outlet (when the boiler is installed with a rear outlet flue system push the flue connector (4) towards the rear of the boiler until it clears the fan outlet).
- Disconnect the electrical connections (5) and the air tubes (6 and 7) from the fan. Note the respective connection points for each tube.
- Remove two screws (8) and remove the fan (9).
- Reassemble in reverse order, ensuring that the air tubes are reconnected to the correct nipple.
- Re-fit combustion chamber cover and front casing.

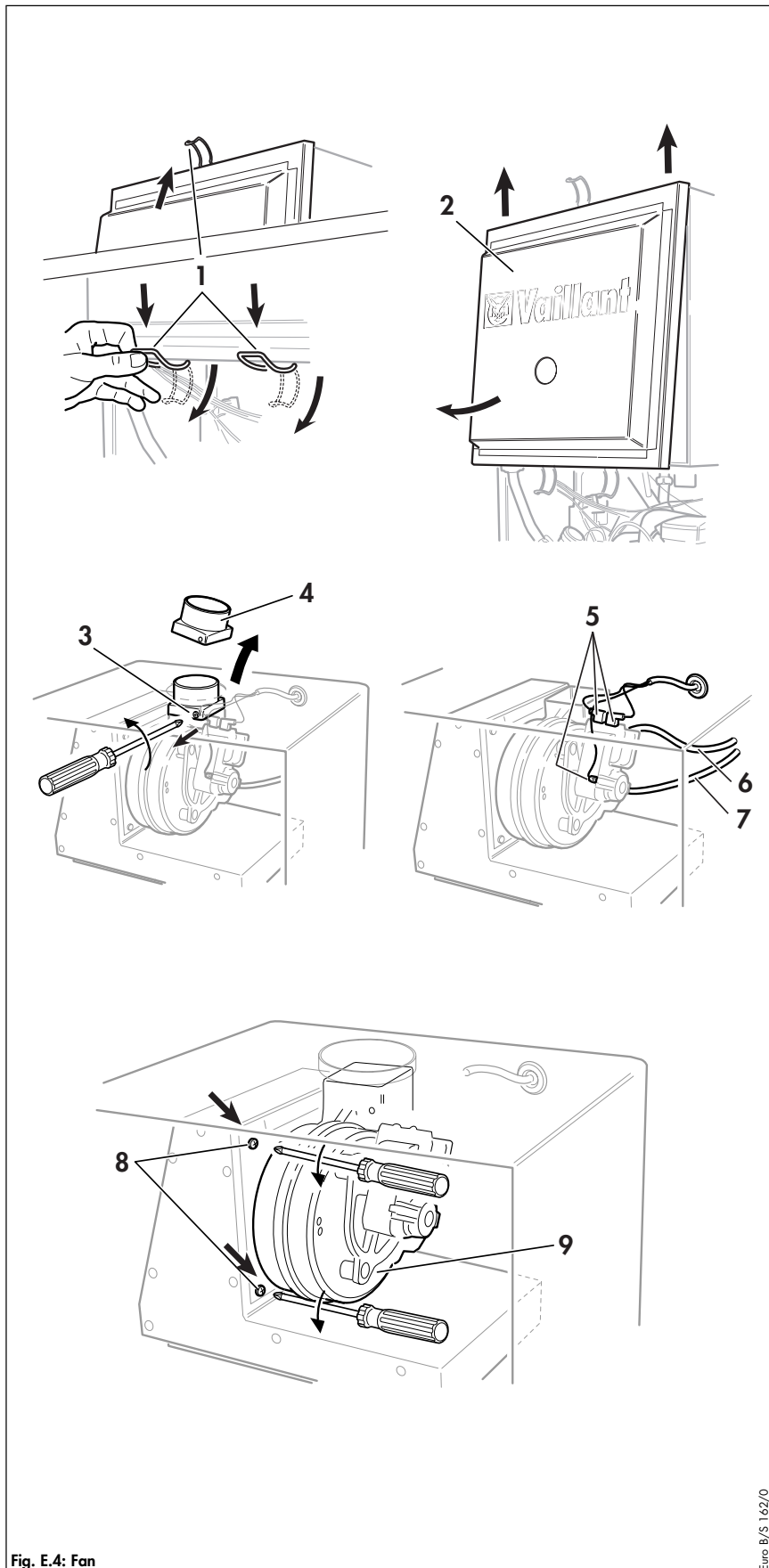
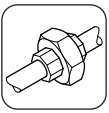
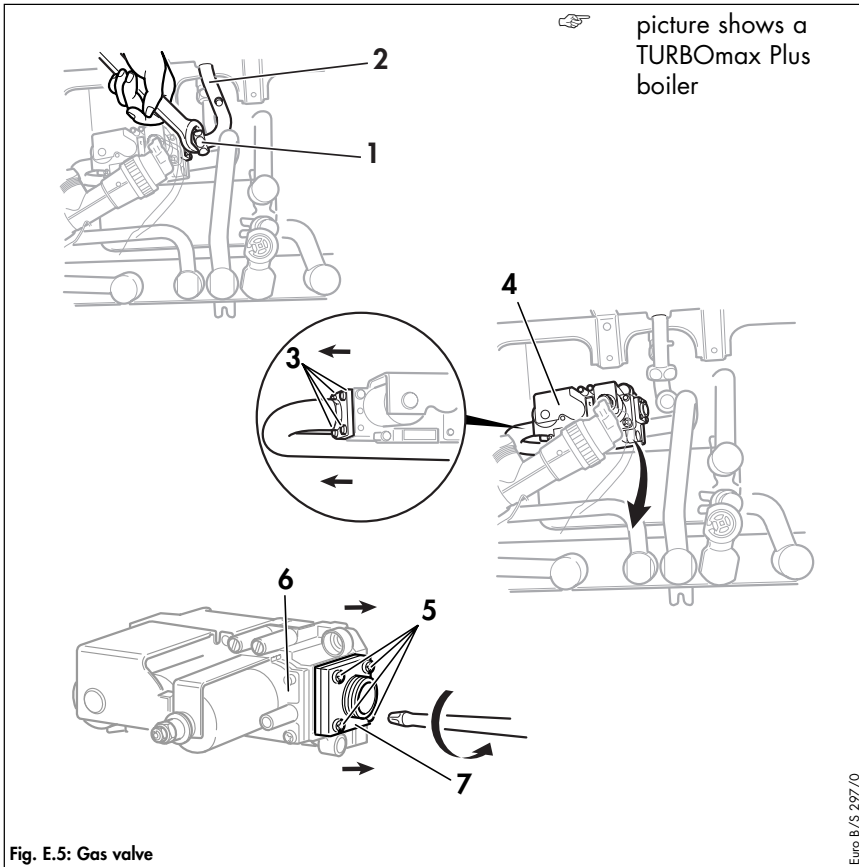

Fig. E.4: Fan



PARTS REPLACEMENT



Gas valve

- Refer to the important information and initial preparation on page 59.
- Loosen screw and pull electrical plug off the gas valve.
- Pull off the two modulating coil wires.
- Disconnect air tube from gas valve.
- Undo nut (1) on the gas valve outlet connection.
- Undo compression nut on the outlet of the gas service valve.
- Pull off the locating spring (8)
- Remove complete gas valve assembly and inlet pipe from the boiler.
- Remove both inlet pipe (12) and outlet (14) connection from the gas valve by removing the eight securing screws (11 and 13) and refit to new gas valve using new seals provided.
- Reassemble in reverse order and test all joints for soundness.
- Set ignition and main burner pressure as detailed in these instructions.

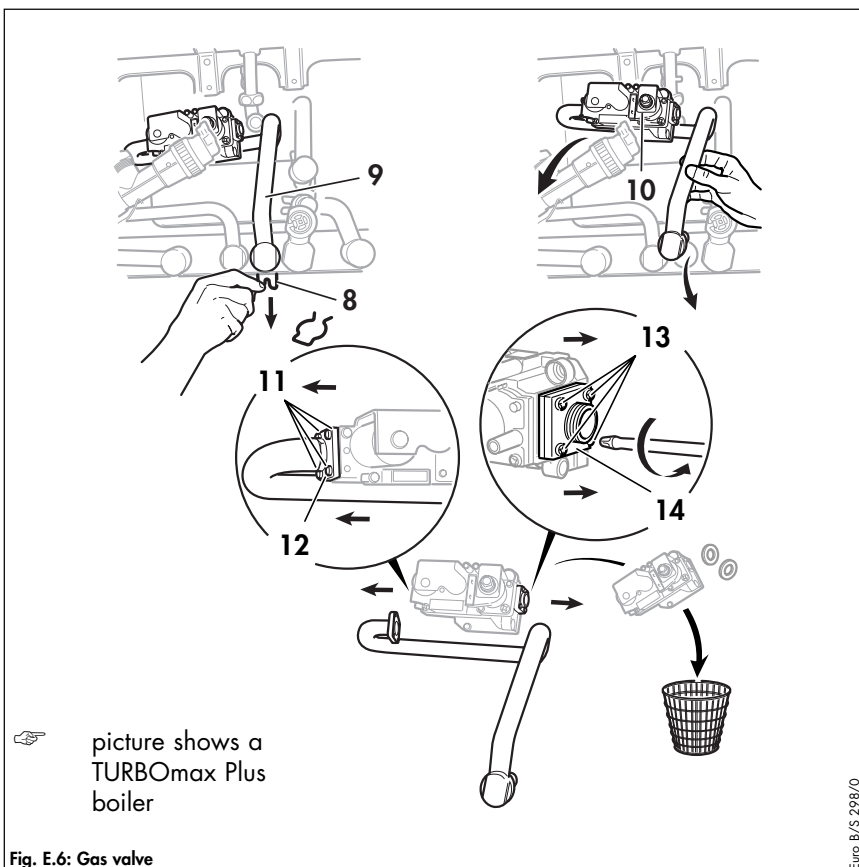

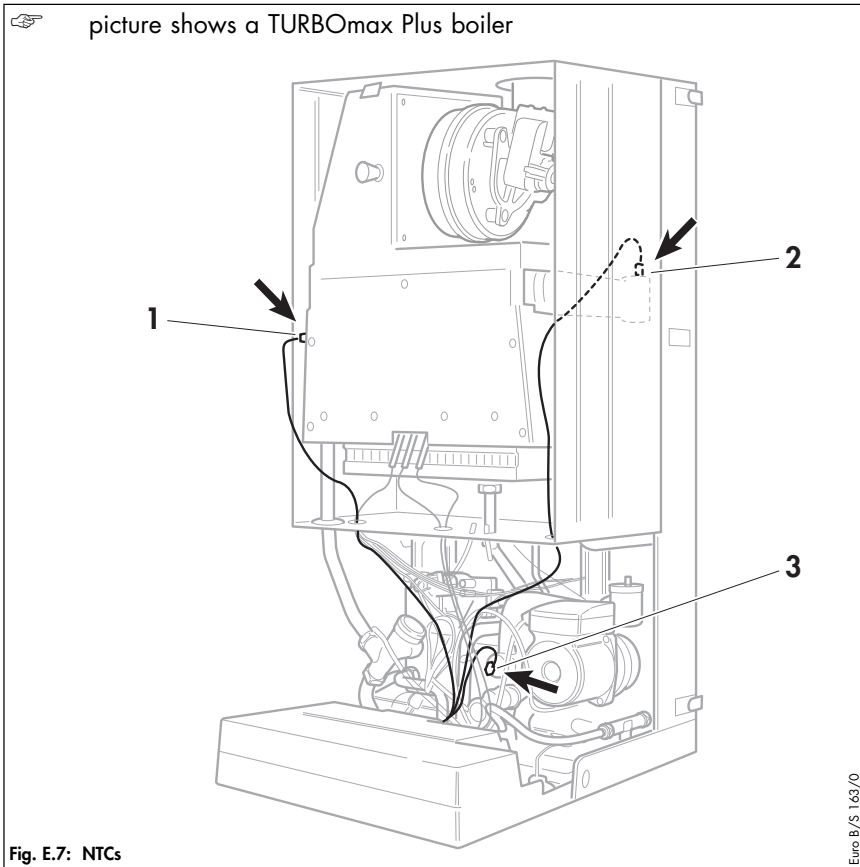
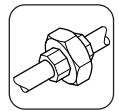

Temperature sensors (NTC'S)

- Refer to the important information and initial preparation on page 59.
- Identify which sensor(s) is to be replaced.
- If required remove combustion chamber cover by unclipping the three clamps.
- Pull off connecting wire from sensor.
- Unscrew NTC sensor (1,2 or 3).
- Replace NTC sensor.
- Reassemble in reverse order.

☞ **NTC sensor 3 for TURBOmax Plus only.**

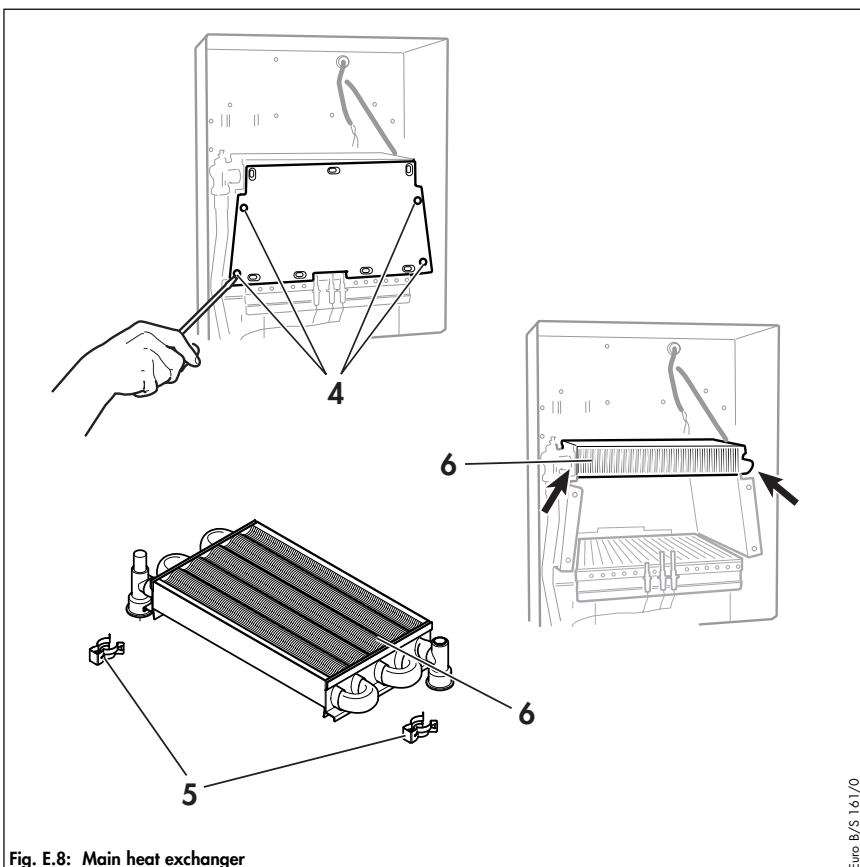

Main heat exchanger

- Refer to the important information and initial preparation on page 59.
- Release central heating water pressure.
- Remove combustion chamber cover by unclipping the three clamps.
- Remove four screws (4) and pull off combustion chamber front panel.
- Remove the fan, the locating spring and the fan hood.
- Pull off the flow clamp (5) and disconnect the return connection.
- Remove the main heat exchanger (6), disconnect the return connection by removing the clamp (5) and pulling the pipe away from the heat exchanger.
- Reassemble in reverse order.

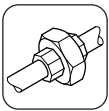

PARTS REPLACEMENT

picture shows a TURBOmax Plus boiler

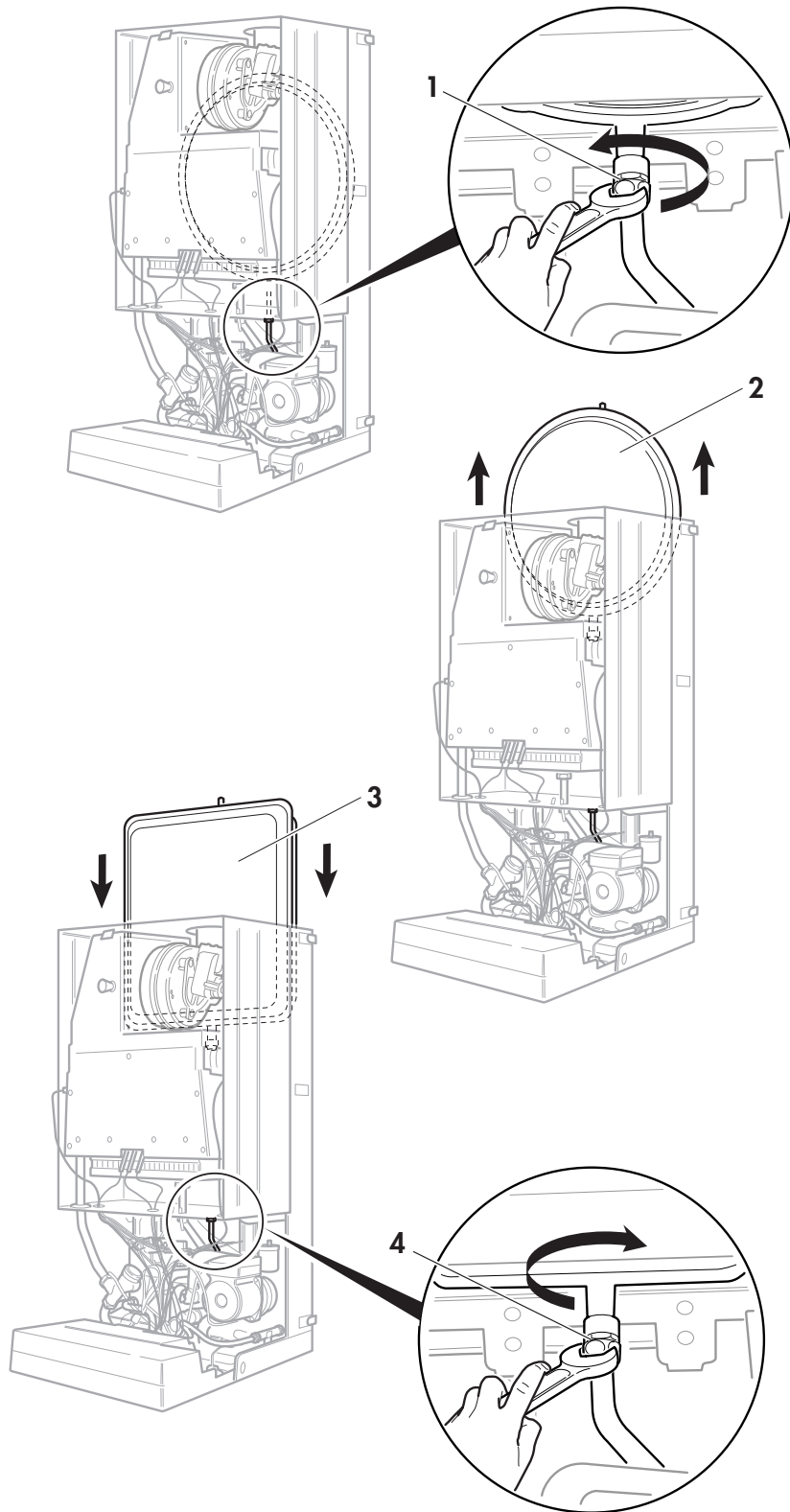

Fig. E.9: Expansion vessel

Expansion vessel

Please note: In the unlikely event of a failure of the CH expansion vessel follow procedure depending upon the installation circumstances.

Boiler installed with top connection air/flue duct to left/right hand side, or vertical flue installation (where 500 mm clearance exists about the boiler).

- Refer to the important information and initial preparation on page 59.
- Release central heating water pressure.
- Disconnect union (1) from expansion vessel.
- Slide the expansion vessel (2) upwards to remove from the boiler.
- Replace in reverse order.

Boiler installed with top connection air/flue duct to the rear, rear flue system or vertical flue installation (where less than 200 mm clearance exists about the boiler).

EITHER

Remove the boiler from the wall as follows:

- Refer to important information and initial preparation on page 57.
- Release central heating water pressure.
- Disconnect external wiring from boiler wiring terminal box.
- Disconnect flow and return connections at union nuts between service valves and boiler.
- Disconnect gas connection at compression joint on gas valve outlet.
- Disconnect domestic hot and cold water connections at union nuts.
- Disconnect the flue from the top of the boiler.
- Remove the boiler from the wall.
- Disconnect union (1) from expansion vessel.
- Slide the expansion vessel (2) upwards to remove from the boiler.
- Replace in reverse order.
- Re-mount the boiler.

OR

A suitable replacement expansion vessel can be fitted externally to the boiler as previously described (if possible on the central heating return in an accessible position). In these circumstances, the replacement vessel must be correctly sized ignoring the original expansion vessel, which can be left in position on the boiler.

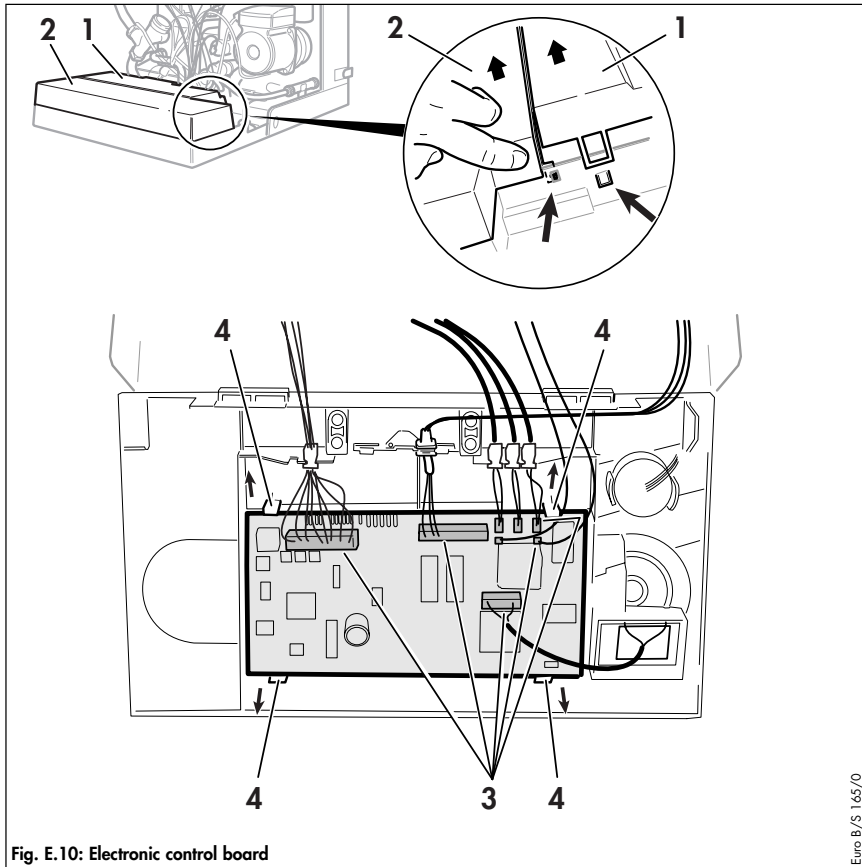
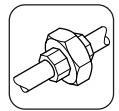

Fig. E.10: Electronic control board

Euro B/S 165/0

Electronic control board

- Refer to the important information and initial preparation on page 59.
- Lower control box.
- Unclip the terminal box cover by releasing the cover retaining clips and lift to remove.
- Unclip the electronic board cover by releasing the clips (2) and lift to remove.
- Disconnect both HT leads from electronic board.
- Unplug all leads from the board.
- Disconnect main power supply and any external controls.
- Push four retaining spring clips (4) out, carefully lift out electronic board.
- Remove the electronic display by releasing the retaining clips.
- Carefully insert the new electronic board into the control box.
- Insert the electronic display by carefully lining up the pins and push until the display locks in to position.
- Re-assemble in reverse order.

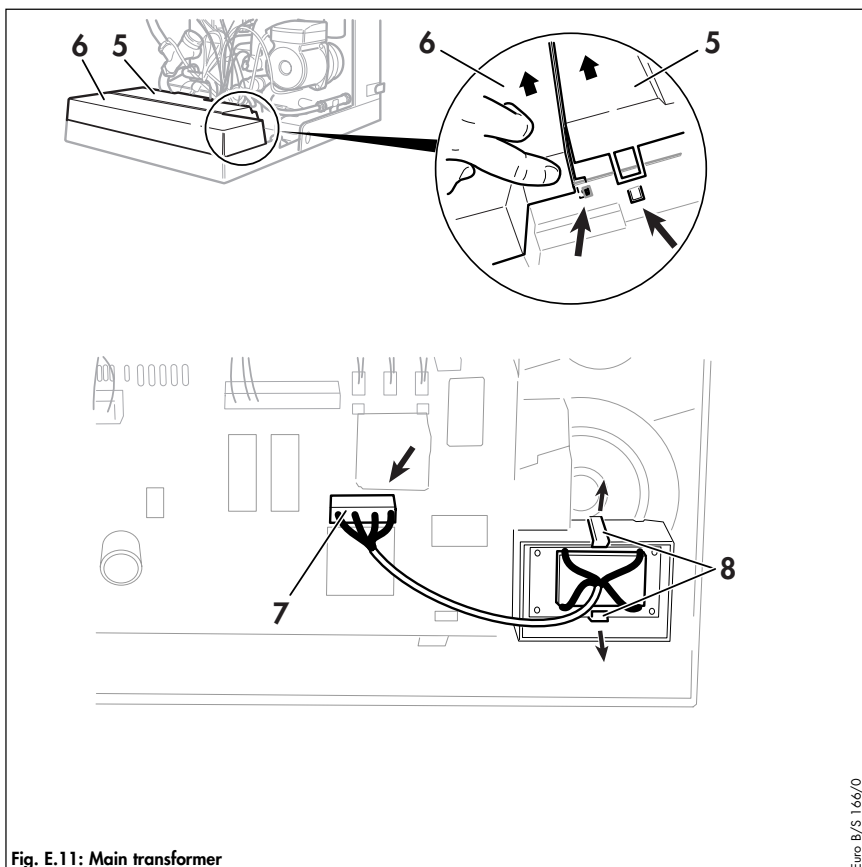
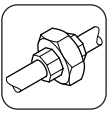

Fig. E.11: Main transformer

Euro B/S 166/0

Main transformer

- Refer to the important information and initial preparation on page 59.
- Lower control box.
- Unclip the terminal box cover by releasing the cover retaining clips and lift to remove.
- Unclip the electronic board cover by releasing the clips and lift to remove.
- Unplug the transformer connecting lead.
- Move clips outwards and remove transformer.
- Re-assemble in reverse order.



PARTS REPLACEMENT

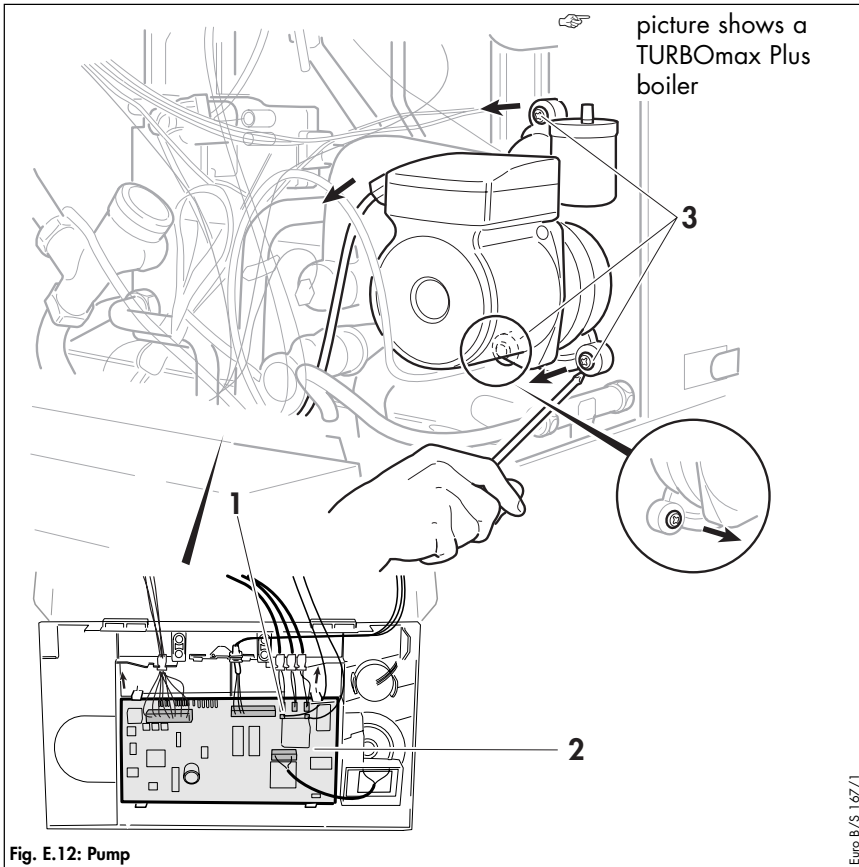

Pump

- Refer to the important information and initial preparation on page 59.
- Release central heating water pressure.
- Unclip the terminal box cover by releasing the cover retaining clips and lift to remove.
- Unplug the pump wire (2) from the electronic board.
- Undo the three pump screws (3).
- Pull pump forward to remove.
- Fit new 'O' rings supplied to pump connections.
- Re-assemble in reverse order.

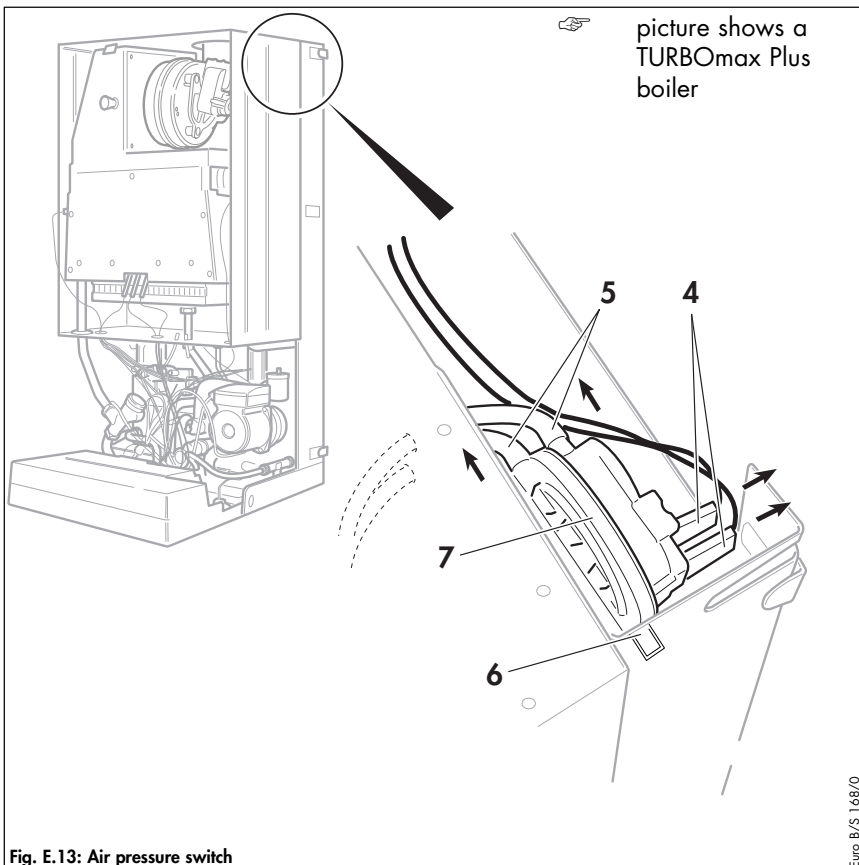

Air pressure switch

- Refer to the important information and initial preparation on page 59.
- Remove clips (6) and lift out pressure switch (7).
- Disconnect electrical connections (4).
- Disconnect air tubes (5).
- Re-assemble in reverse order.

Note: Air tubes should be reconnected:
P1 (marked on air pressure switch) to white tube.
P2 (marked on air pressure switch) to blue tube.

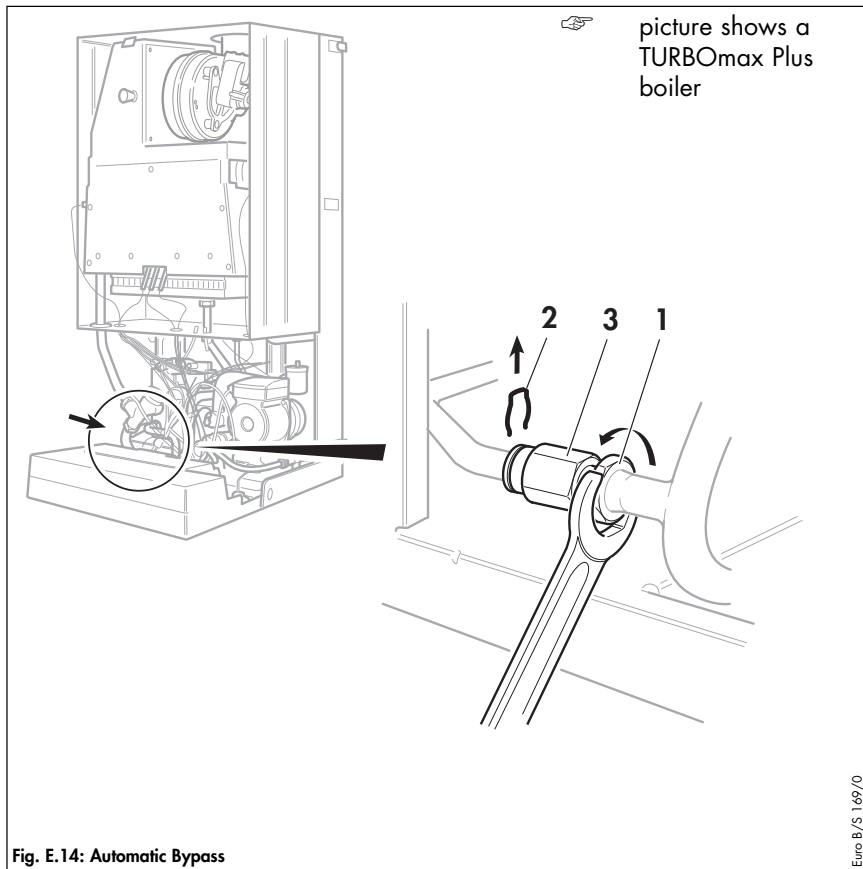
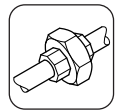

Fig. E.14: Automatic Bypass

Automatic bypass

- Refer to the important information and initial preparation on page 59.
- Release central heating water pressure.
- Remove spring clip (2)
- Undo union (1), remove bypass/connecting pipe.
- Pull apart bypass and connecting pipe.
- Re-assemble in reverse order.

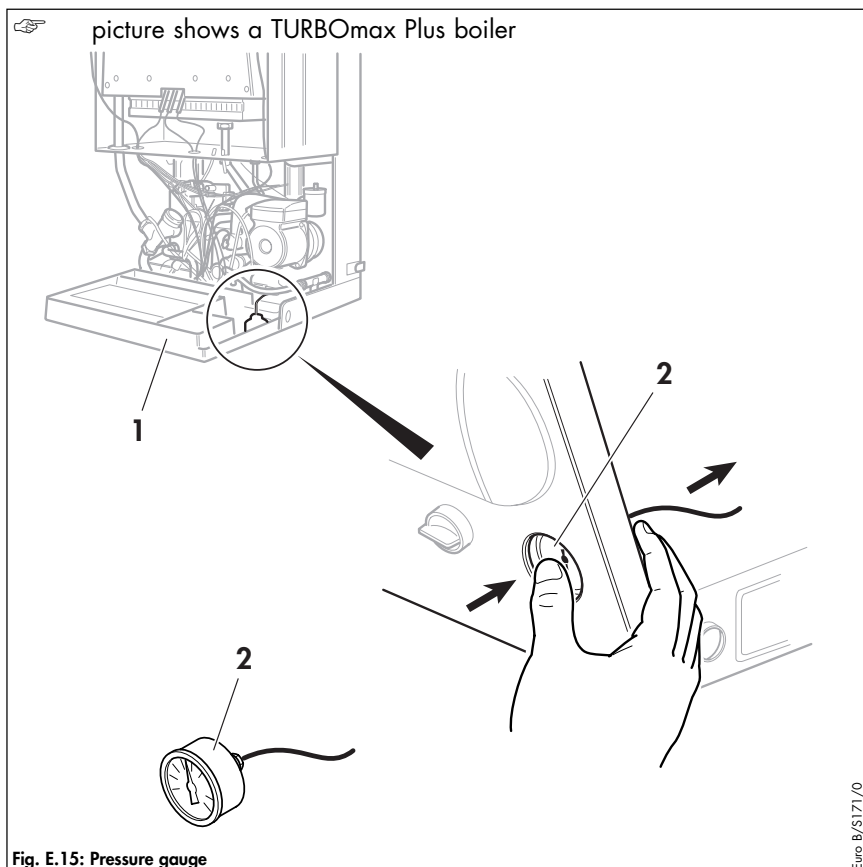
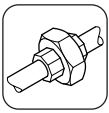

Fig. E.15: Pressure gauge

Pressure gauge

- Refer to the important information and initial preparation on page 59.
- Release central heating water pressure.
- Pull out the four retaining clips and remove the pressure gauge from fascia.
- Remove retaining clip and disconnect pressure gauge capillary tube.
- Re-assemble in reverse order.



PARTS REPLACEMENT

TURBOmax Plus

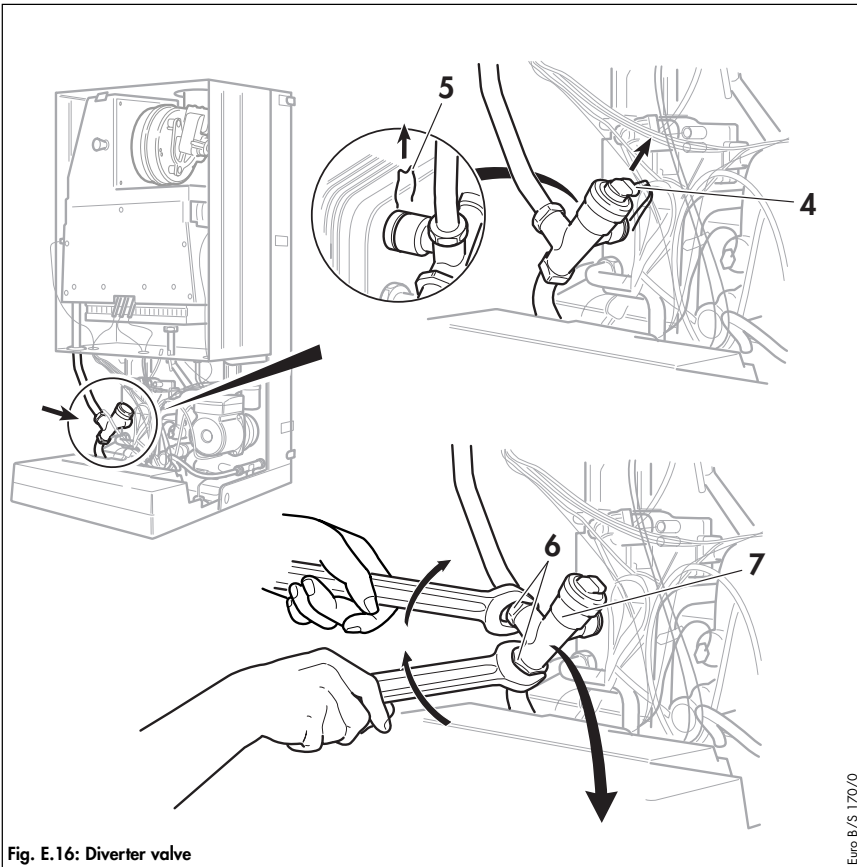

Fig. E.16: Diverter valve

Euro B/S 172/0

Diverter valve (TURBOmax Plus only)

- Refer to the important information and initial preparation on page 59.
- Release central heating water pressure.
- Disconnect the plug (4) from the diverter valve.
- Remove the spring clip (5).
- Undo the unions (6) and remove the diverter valve.
- Re-assemble in reverse order.

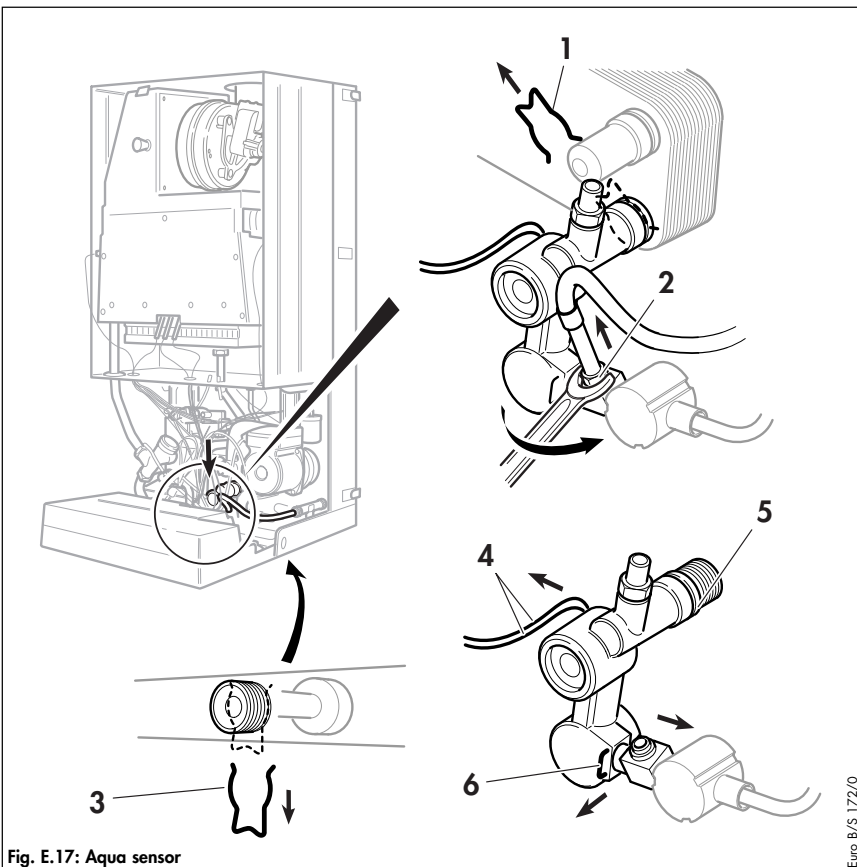
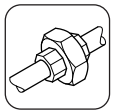

Fig. E.17: Aqua sensor

Euro B/S 172/0

Aqua sensor (TURBOmax Plus only)

- Refer to the important information and initial preparation on page 59.
- Release central heating water pressure.
- Remove the spring clip (1).
- Ensure filling loop hose is disconnected.
- Undo union nut between the cold water inlet service valve and aqua sensor.
- Remove the spring clip (3).
- Pull the aqua sensor forward and release cable.
- Remove aqua sensor.
- Remove the spring clip (6) and disconnect filling loop valve.
- Re-assemble in reverse order.



DHW heat exchanger (TURBOMax Plus only)

- Refer to the important information and initial preparation on page 59.
- Release central heating water pressure.
- Remove the diverter valve and pump as previously described.
- Disconnect wire from the NTC.
- Remove the spring clips (3 and 4).
- Undo the bottom left hand union (2).
- Push the heat exchanger (5) backwards to disconnect.
- Re-assemble in reverse order.

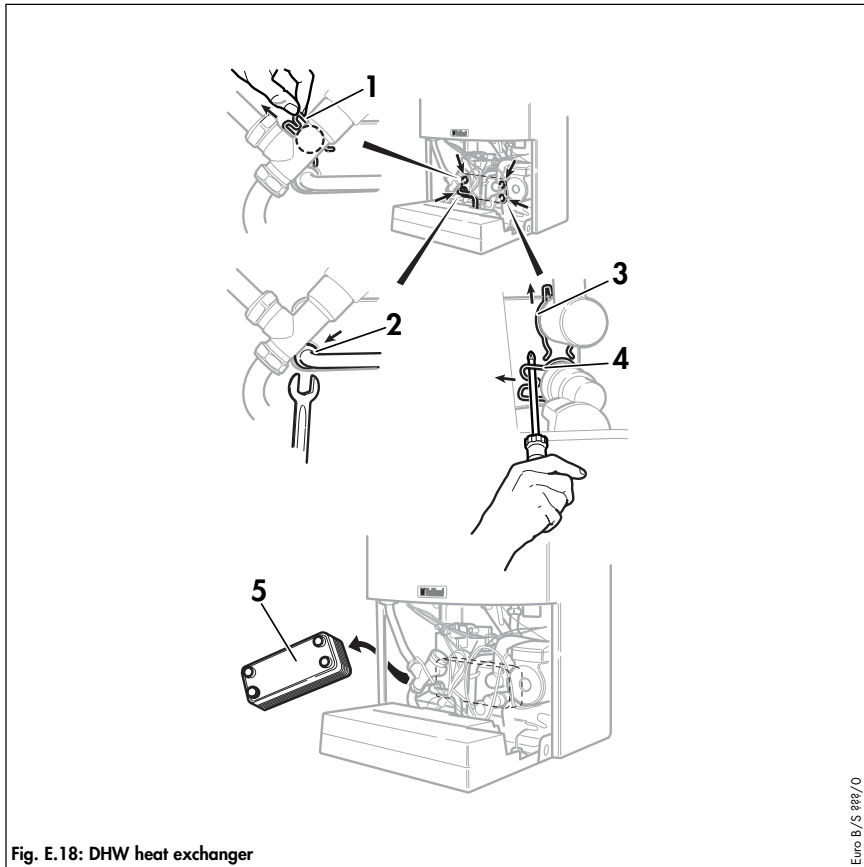

Fig. E.18: DHW heat exchanger

Euro B/S 888/0

Pressure relief valve

- Refer to the important information and initial preparation on page 59.
- Release central heating water pressure.
- Remove the spring clip (5).
- Disconnect the discharge pipe from the pressure relief valve.
- Remove pressure relief valve.
- Re-assemble in reverse order.

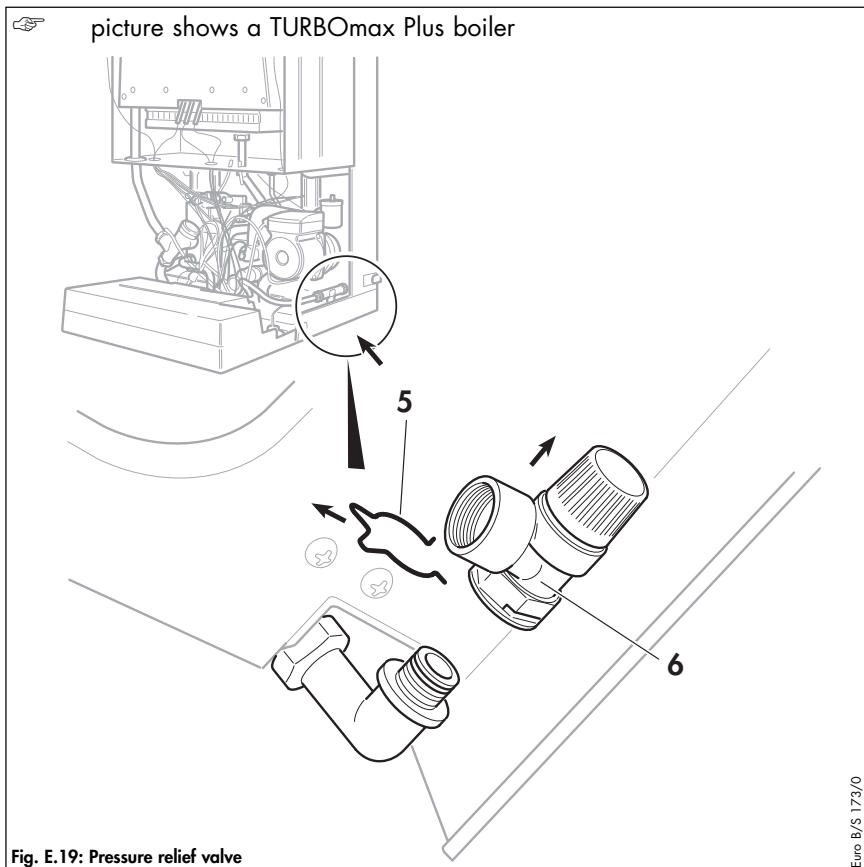
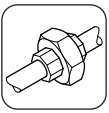

Fig. E.19: Pressure relief valve

Euro B/S 173/0



PARTS REPLACEMENT

I
O

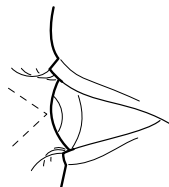
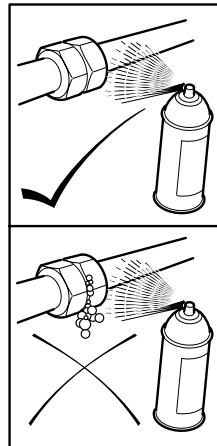
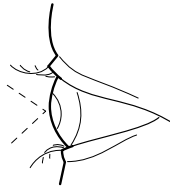
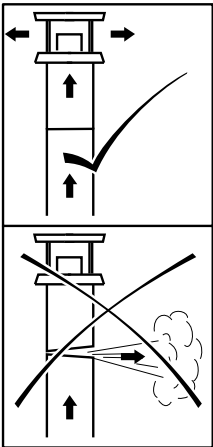
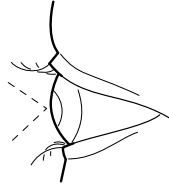
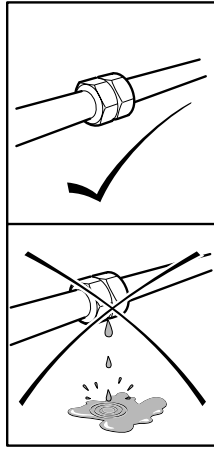
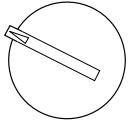

Checking functions

Procedure

On completion operate the system run to ensure that the boiler is working correctly.

- Operate the system, following the operating instructions supplied with the boiler.
- Check the system for water leaks and escaping gas.
- Check that the flue has been correctly installed, according to the separate flue instructions.
- Check the burner for correct ignition and flame picture.
- TURBOmax Plus only: Check the hot water system for correct operation.
- Check the heating system for correct operation.

Fig. E.20: Functional check

Euro B/S 058/O



INTRODUCTION

The TURBOmax Plus and THERMOcompact boilers have an inbuilt advanced multifunction diagnostic display to assist with fault finding in the unlikely event of a boiler malfunction. The display features the following four modes:

Normal Mode

Under normal conditions the boiler display will show the boiler flow temperature, this indicates that the boiler is operating correctly after an internal self check.

Status Mode

The status display is helpful in diagnosing faults where a fault code is not displayed.

Diagnostic Mode

In order to assist with the pinpointing of a particular fault it is possible to use the boiler display in a diagnostic mode to interrogate the boiler about the status of certain components.

Fault Mode

Should a fault develop in the boiler the display will show a fault code indicating what the problem may be.

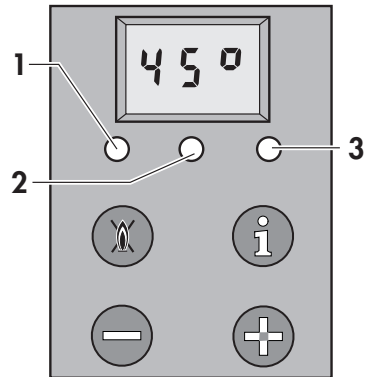

Fig. St. 1: LED indicators

Eno B/S.071/0

Indicator lights (TURBOmax Plus only)

The boiler control panel also contains three indicator lights whose function is as follows:

- Red lock out indicator (1), when illuminated boiler is at lock out.
- Yellow flame indicator (2), when illuminated main burner is ignited.
- Green warmstart indicator (3)
Illuminated = Warmstart switched ON
Not illuminated = Warmstart is switched OFF and there is no demand for hot water
Flashing = There is either a demand for hot water or warmstart

Indicator lights (THERMOcompact only)

The boiler control panel also contains three indicator lights whose function is as follows:

- Red lock out indicator (1), when illuminated boiler is at lock out.
- Yellow flame indicator (2), when illuminated main burner is ignited.
- Green indicator (3) is illuminated but has no function.



Logical fault finding procedure

These checks must be carried out before attempting to use the fault finding guide.

1. Carry out electrical safety checks (See Section 'Preliminary Electrical Checks').
2. Check that the external electricity supply to the boiler is on, and a supply of 230 V~ is present between boiler terminals 'L' and 'N'.
3. Check that the gas supply to the boiler is on, that it has been correctly purged and that an inlet pressure of 20 mbar is available at the gas valve. (See Section 'Gas Supply').
4. Ensure the heating system is full of water and charged to between 1 and 1.5 bar. If not, refill and vent the system. (See Section 'Filling the heating system').
Ensure boiler flow and return service valves are open.
5. Check that the main ON/OFF control is set to the 'ON' position.
6. Set the central heating temperature to maximum.
7. Set the domestic hot water temperature to maximum (TURBOmax only).
8. Check that all external controls are on and calling for heat (if, no external controls are fitted, boiler terminals 3 and 4 must be linked). Check that the boiler anti-cycling economiser is not engaged.

Procedure

Note: Always check the operation of the boiler for central heating first before checking hot water operation. Do not open a hot water tap unless instructed to do so by the fault finding guide (TURBOmax only).

1. If a fault code is showing in the boiler display follow the fault finding charts referring also to the fault code and diagnostic mode tables.
2. If the boiler is not functioning correctly and a fault code is not showing in the boiler display follow the fault finding charts referring also to the status mode table.
3. **Note:** If the boiler display is completely blank initially check the two fuses (Isolate the electrical supply before checking the fuses, spare fuses are located on the inside of the control box rear cover).

To access the various modes press the buttons on the control panel as follows:

Mode	To display the required mode	To return to Normal mode
Status mode	Press „i“ button	Press „i“ button
Diagnostic mode	Press the „i“ and „+“ button simultaneously	Press the „i“ and „+“ button simultaneously

Please note: If no key is pressed for approx. 4 minutes the display will automatically change back to Normal mode.



FAULT FINDING

Status Mode

The status mode provides information about the current operating status of the boiler.

To display status mode proceed as follows:

- Press the „i” button below the display, and a status code will appear in the display indicating the current operational status of the boiler (see table below).

To cancel the status code mode proceed as follows:

- Press the „i” button below the display
- or
- Do not press any key for approximately four minutes. The display will now revert back to showing the current flow temperature.

Display	Indication	TURBOmax Plus	THERMOcompact
S.00	No heat demand (heating operation)	x	x
S.01	Fan running (heating operation)	x	x
S.02	Pump running – pre ignition (heating operation)	x	x
S.03	Ignition sequence (heating operation)	x	x
S.04	Burner ignited (heating operation)	x	x
S.07	Pump over run (heating operation)	x	x
S.08	Anti cycling mode (heating operation)	x	x
S.10	Hot water demand (hot water operation)	x	
S.11	Fan running (hot water operation)	x	
S.13	Ignition sequence (hot water operation)	x	
S.14	Burner ignited (hot water operation)	x	
S.16	Fan over run (hot water operation)	x	
S.17	Pump over run (hot water operation)	x	
S.20	Warmstart demand (warm start)	x	
S.21	Fan running (warm start)	x	
S.23	Ignition sequence (warm start)	x	
S.24	Burner ignited (warm start)	x	
S.27	Pump over run (warm start)	x	
S.28	Anti cycling mode (warm start)	x	
S.30	No heating demand from external controls	x	x
S.31	Summer mode (heating control knob in off position)	x	x
S.33	Check air/flue system	x	x
S.34	Frost protection mode	x	x
S.36	No heating demand from low voltage controls	x	x
S.39	Contact thermostat has been activated (under floor systems)	x	x
S.53	Delay mode due to lack of water in system (~20 mins.)	x	x

Table St. 1: Status modes



Diagnostic Modes

In order to assist with the pinpointing of a particular fault it is possible to use the boiler display in a diagnostic mode to interrogate the boiler about the status of certain components.

- Press the „i“ and „+“ buttons below the display simultaneously. The display will now show „d.00“.

- Use „+“ or „-“ buttons to scroll up or down to the desired diagnostic number.
- Press „i“ button to display the corresponding diagnostic information.
- If necessary, you can now alter the value by pressing „+“ or „-“ buttons. (When altering values display will flash). Press and hold the „i“ button to save the value to memory, when the value is saved the display will stop flashing.

Diagnostic mode is cancelled as follows:

- Press the „i“ and „+“ buttons simultaneously
- or
- Do not press any key for approximately four minutes. The display will now revert back to showing the current flow temperature.

Display	Indication	Displayed values/adjustment values
d.00	Part load setting	0, 1, 2 ...15 (factory-adjusted to 15 = max. rating)
d.01	Water pump over run	1, 2, 3, ...60 min (factory adjusted setting: 5 min)
d.02	Maximum burner anti cycling period at 20 °C flow temperature	8 - 60 min (predelivery setting: 15 min)
d.03	Not applicable	
d.04	Not applicable	
d.05	Flow temperature setting	°C
d.06	Not applicable	
d.07*	1. Vantage hot water temperature (not applicable) 2. Warmstart temperature setting (applies to TURBOmax Plus only)	1. 15 - 75 °C 2. 40 - 65 °C
d.08	External controls heat demand	0 = open, no demand 1 = closed, demand
d.09	Not applicable	
d.10	Pump status	1 = ON 0 = OFF
d.11	External pump status	1 = ON 0 = OFF
d.21	Flame rectification	1 = ON 0 = OFF
d.22*	Domestic hot water demand	1 = ON 0 = OFF
d.23	Summer/winter function (control knob)	1 = winter 0 = summer
d.24	Air pressure switch	1 = Closed 0 = Open
d.25*	Warmstart status (TURBOmax Plus)	1 = ON 0 = OFF
d.30	Gas valve status	1 = ON 0 = OFF
d.35*	Diverter valve position (THERMOcompact)	1 = hot water 0 = heating system

Table St.2: Diagnostic Modes 1 of 2

* TURBOmax Plus only



FAULT FINDING

Display	Indication	Displayed values/adjustment values
d.37	Modulator current	mA
d.40	Actual flow temperature	°C
d.45	Not applicable	
d.46	Not applicable	
d.47	Not applicable	
d.50	Maximum flow temperature	°C
d.53	Not applicable	
d.54	Not applicable	
d.60	Number over heat cut off operations	
d.61	Number of lock outs	
d.64	Average ignition time	s
d.65	Maximum ignition time	s
d.67	Remaining anti cycling period	min
d.68	Number of unsuccessful attempted 1 st ignitions	
d.69	Number of unsuccessful attempted 2 nd ignitions	
d.71	Maximum target value for heating system flow temperature	0 = 82 °C 1 = 87 °C (factory setting: 82 °C)
d.72*	Pump over run (for loading warmstart or Vantage cylinders)	0, 1, 2, ... 250 s (factory-adjusted to: 80 s)
d.73*	Offset warmstart temperature value	-15, -14.....+5 K (factory-adjusted -15 K)
d.74	Not applicable	
d.75	Maximum hot water priority operation time (Vantage only)	20, 21, 22 ... 90 min (factory-adjusted to: 30 min)
d.80**	Number of heating system operating hours (Total)	h
d.81*	Number of hot water system operating hours (Total)	h
d.82	Number of heating system cycles (Total)	
d.83*	Number of hot water system cycles (Total)	
d.90	Not applicable	
d.91	Not applicable	



Fault codes

Fault codes take priority over all other display functions in the event of a system fault occurring. If multiple faults occur, the corresponding fault codes are displayed alternately for about two seconds each.

Fault memory

The fault memory stores details of the ten most recent faults.

- Press the „i“ and „-“ buttons simultaneously.
- Use the „+“ button to scroll back through the list of memorised errors.

To cancel fault error memory display mode, proceed as follows:

- Press the „i“ button below the display.
- or
- Do not touch any key for about four minutes. The display will now revert back to showing the current flow temperature.

Display	Indication	Cause
F.00	Flow-NTC: - NTC broken - NTC cable broken - Defective connection at NTC - Defective connection at electronics	Flow-NTC cable defective/broken NTC faulty
F.01	Return-NTC: - NTC broken - NTC cable broken - Defective connection at NTC - Defective connection at electronics	Return-NTC cable defective/broken NTC faulty
F.10	Short circuit - flow-NTC (< 130 °C)	NTC- plug shorted to casing NTC defective
F.11	Short circuit - return-NTC (< 130 °C)	NTC- plug shorted to casing NTC defective
F.20	Over heat cut off activated	Maximum temperature exceeded
F.22	Low water or no water in appliance	No water in system Pump defective Pump lead defective
F.27	no demand to gas valve	Electronic board defective Gas valve defective
F.28	Boiler goes to lock out	No gas Insufficient gas Incorrect gas valve adjustment Electrode defective Ignition lead defect Electronic igniter defective
F.29	Flame extinguished re-ignition unsuccessful	Gas supply absent or insufficient
F.42	Faulty cable loom	Faulty or incorrect loom fitted
F.43	Faulty cable loom	Faulty or incorrect loom fitted
F.60 to F.67	Irreversible electronic system malfunction	Electronic system defective

Table St.4: Fault codes



FAULT FINDING

Sheet A

Check electrical supply, appliance fuses and on/off control

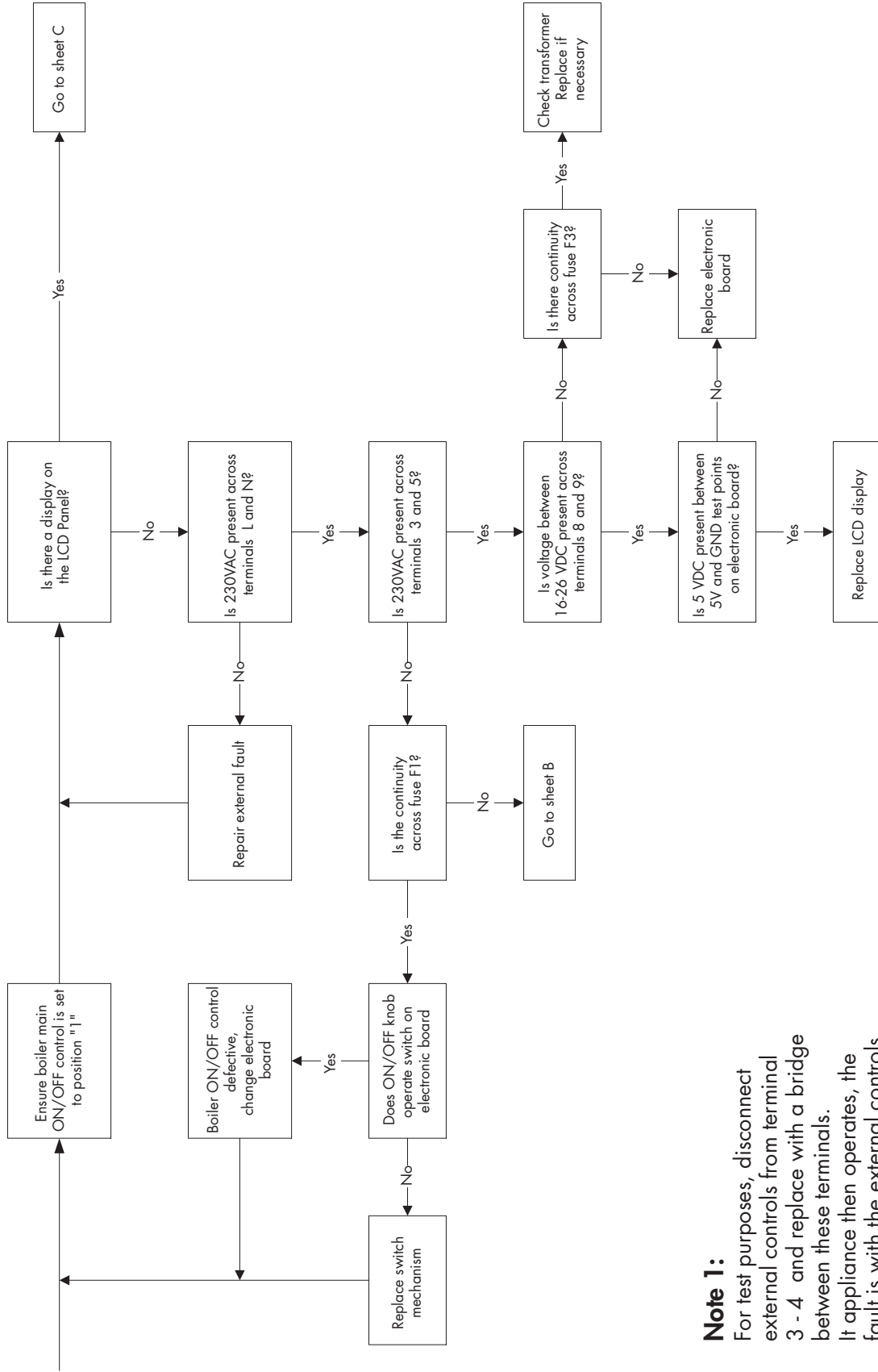

Note 1:

For test purposes, disconnect external controls from terminal 3 - 4 and replace with a bridge between these terminals. It appliance then operates, the fault is with the external controls.



Sheet B

Check operation of pump and fan

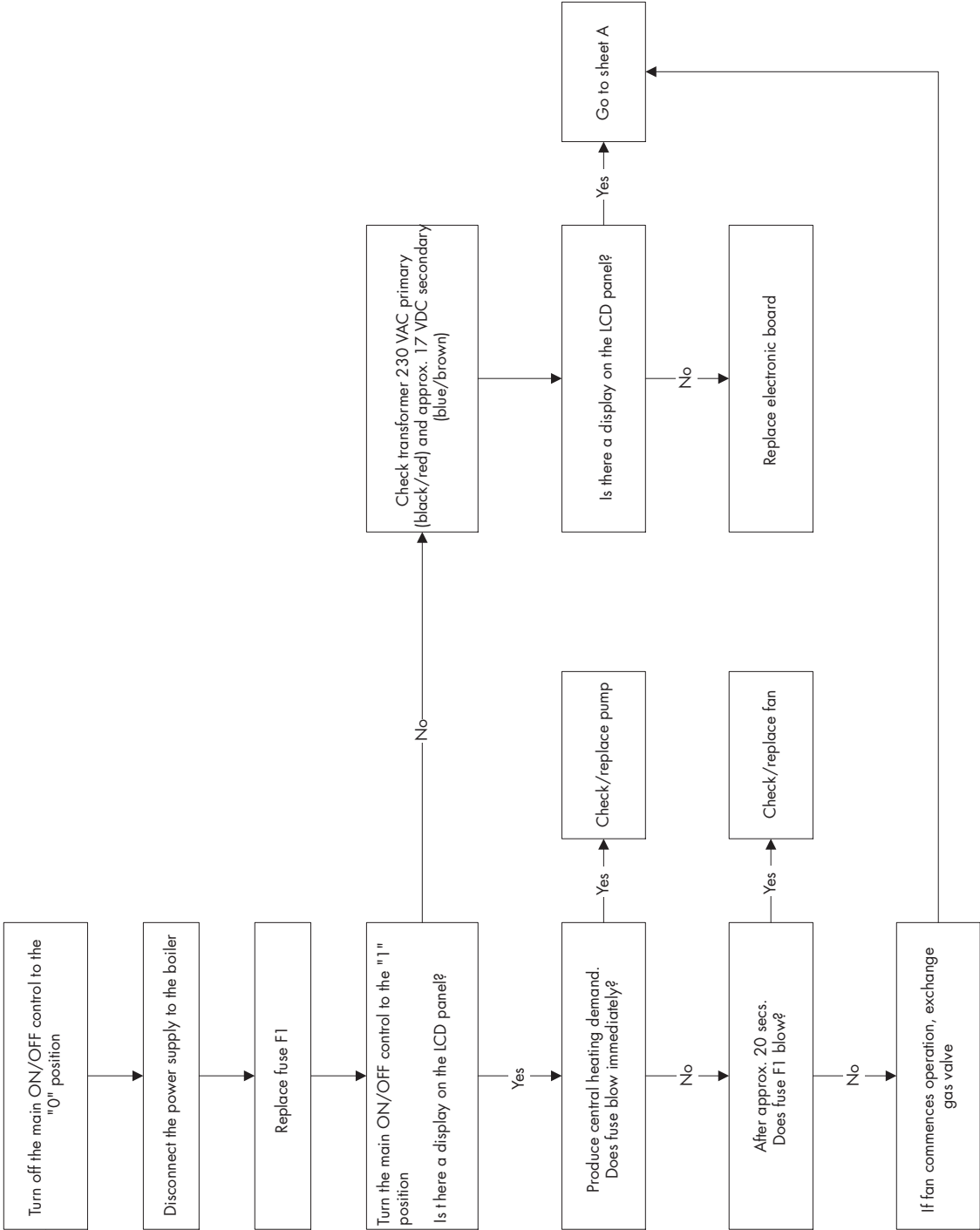



Sheet C

Check central heating and controls

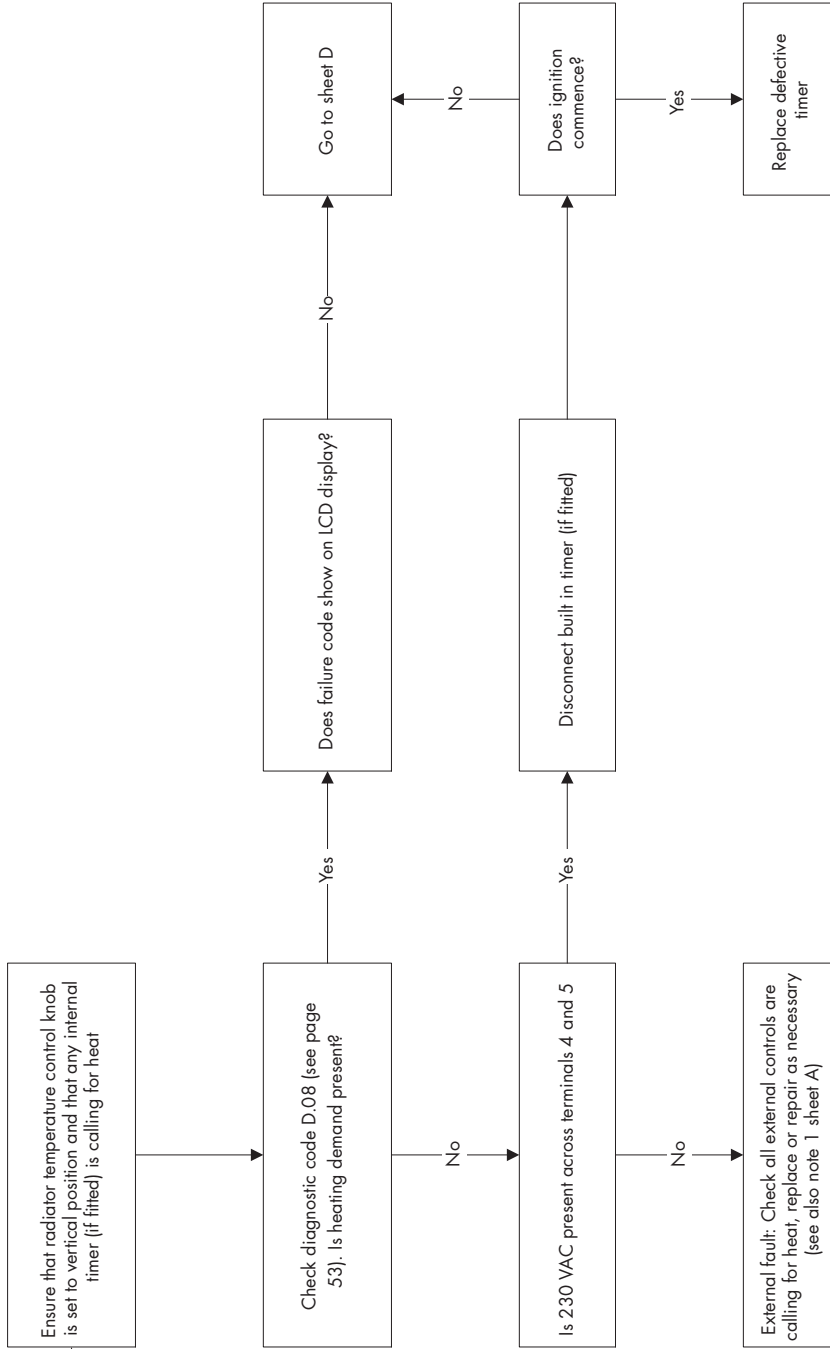



Sheet D

Check flue and ignition system

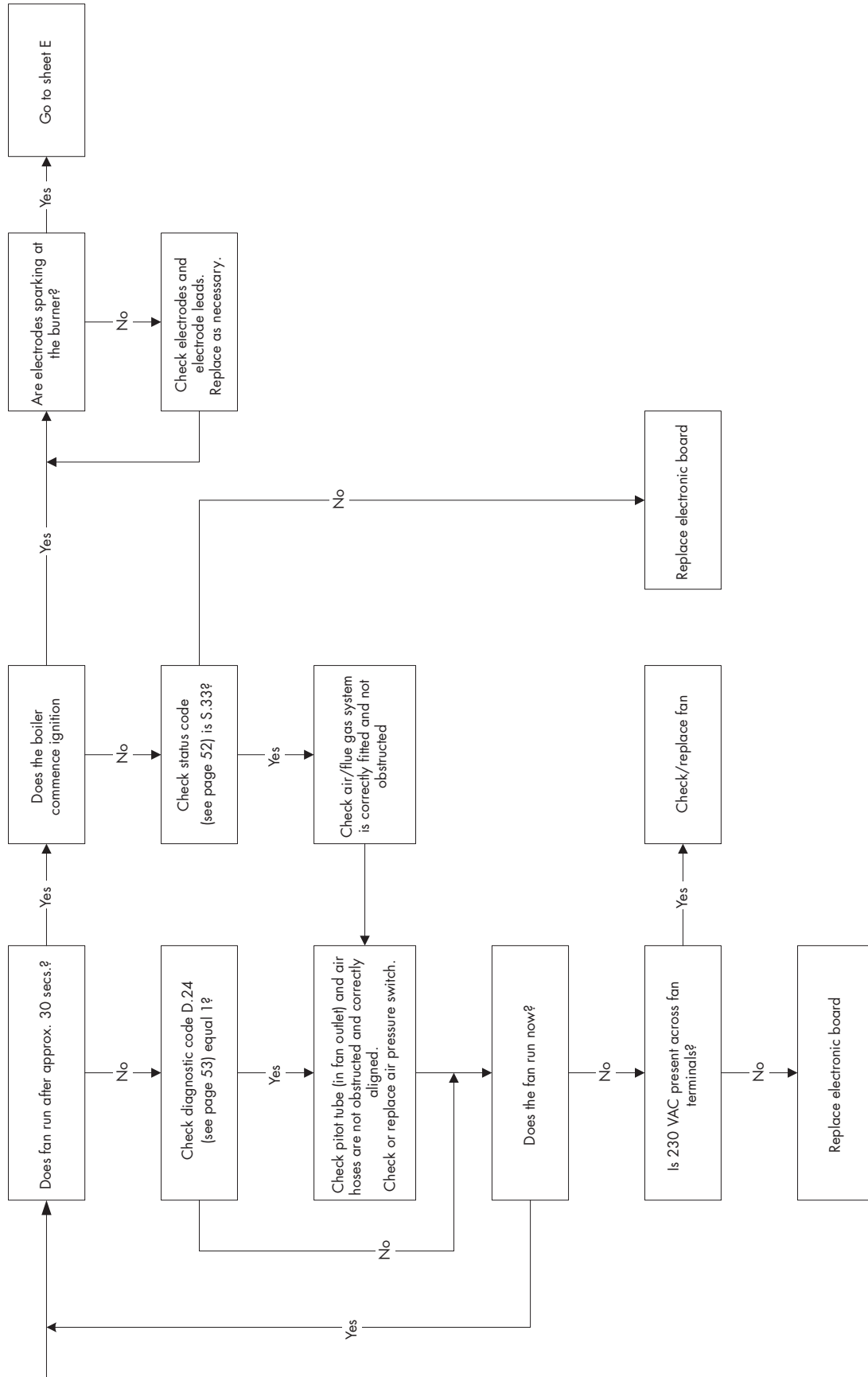



FAULT FINDING

Sheet E

Check gas valve and central heating system pressure

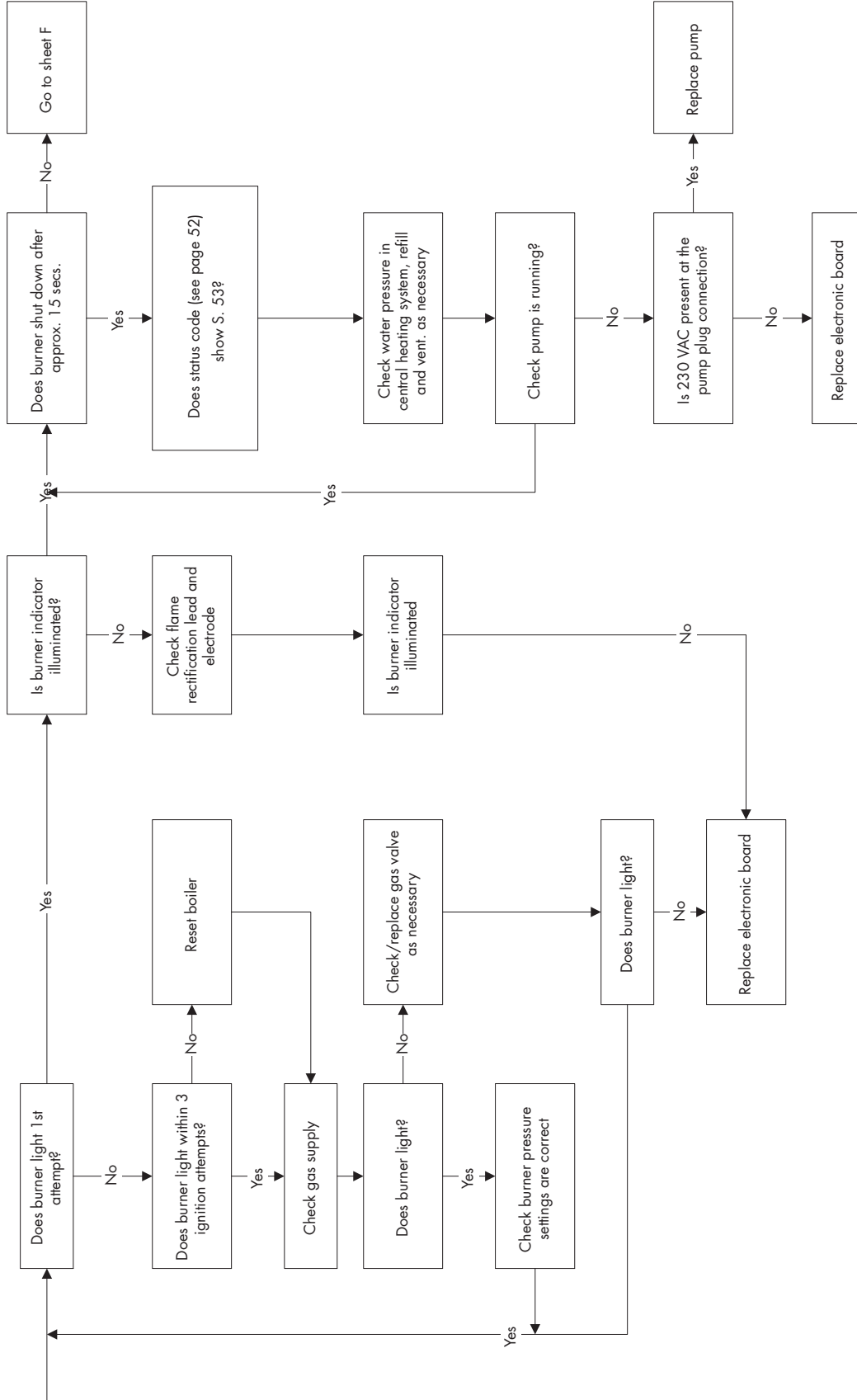



Sheet F

Check operation of burner and modulation

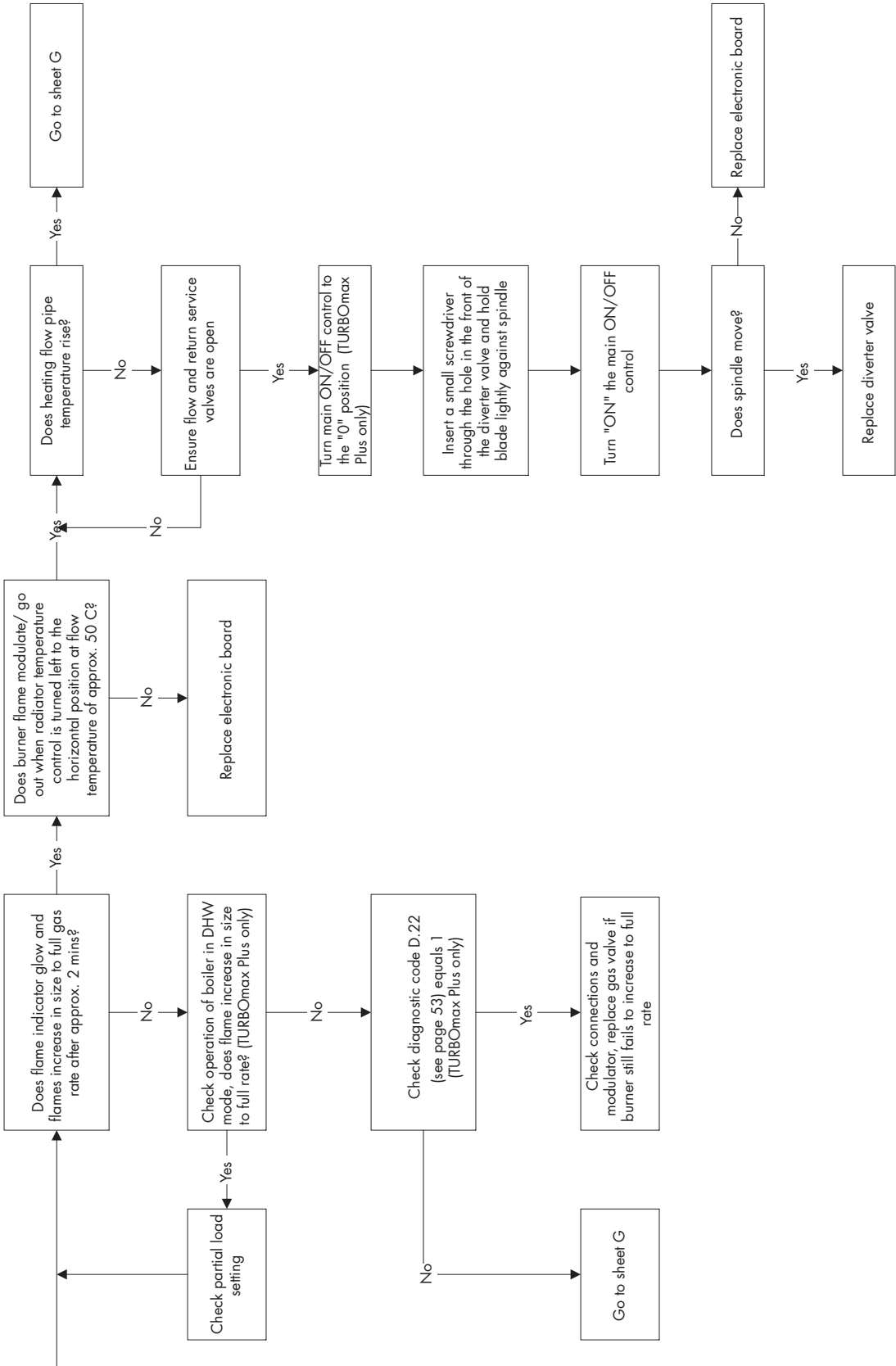



Check D.H.W operation (TURBOMax Plus only)

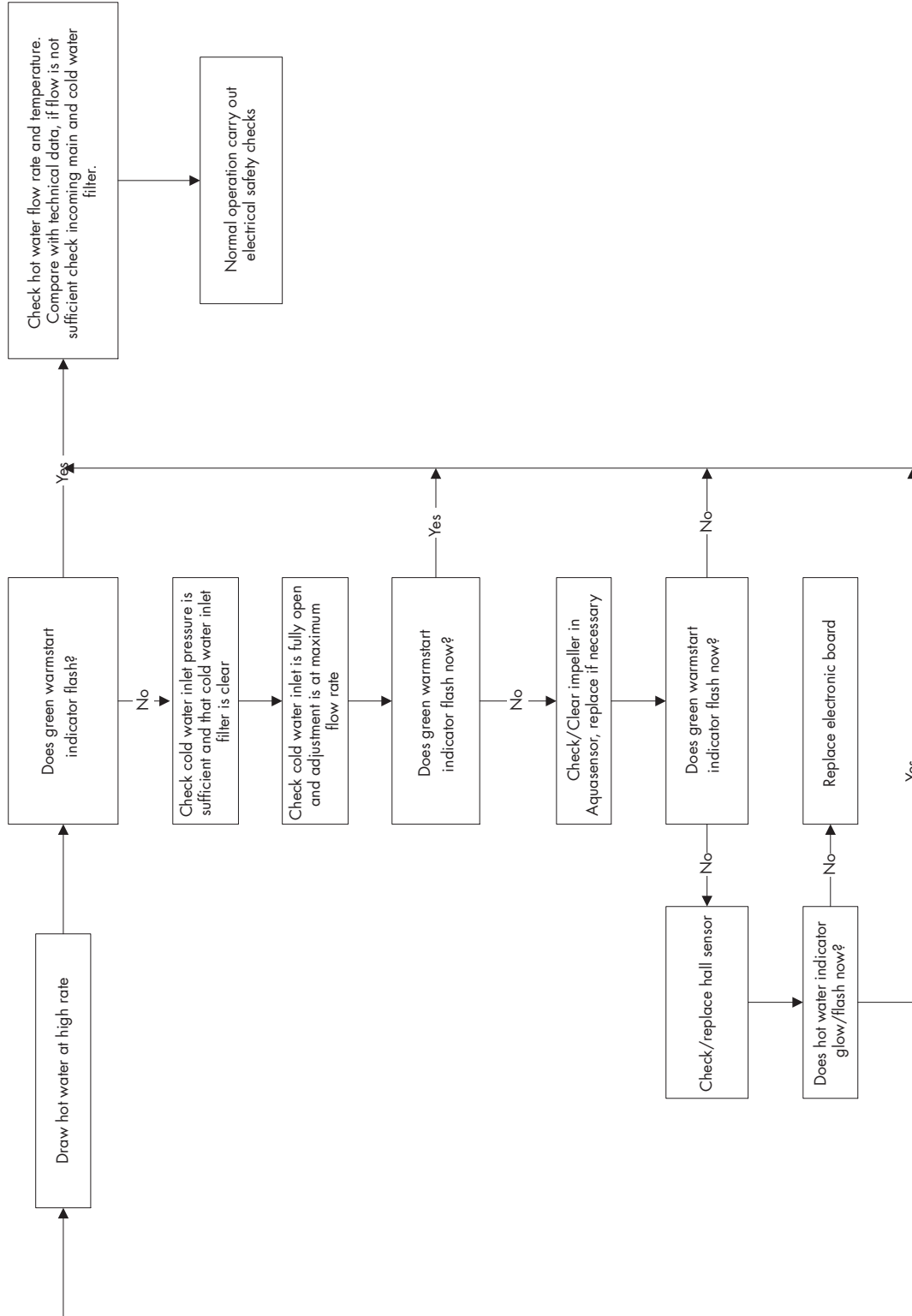

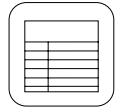

Functional Flow diagram: TURBOmax Plus 824/2 E, 828/2 E

TURBOmax Plus

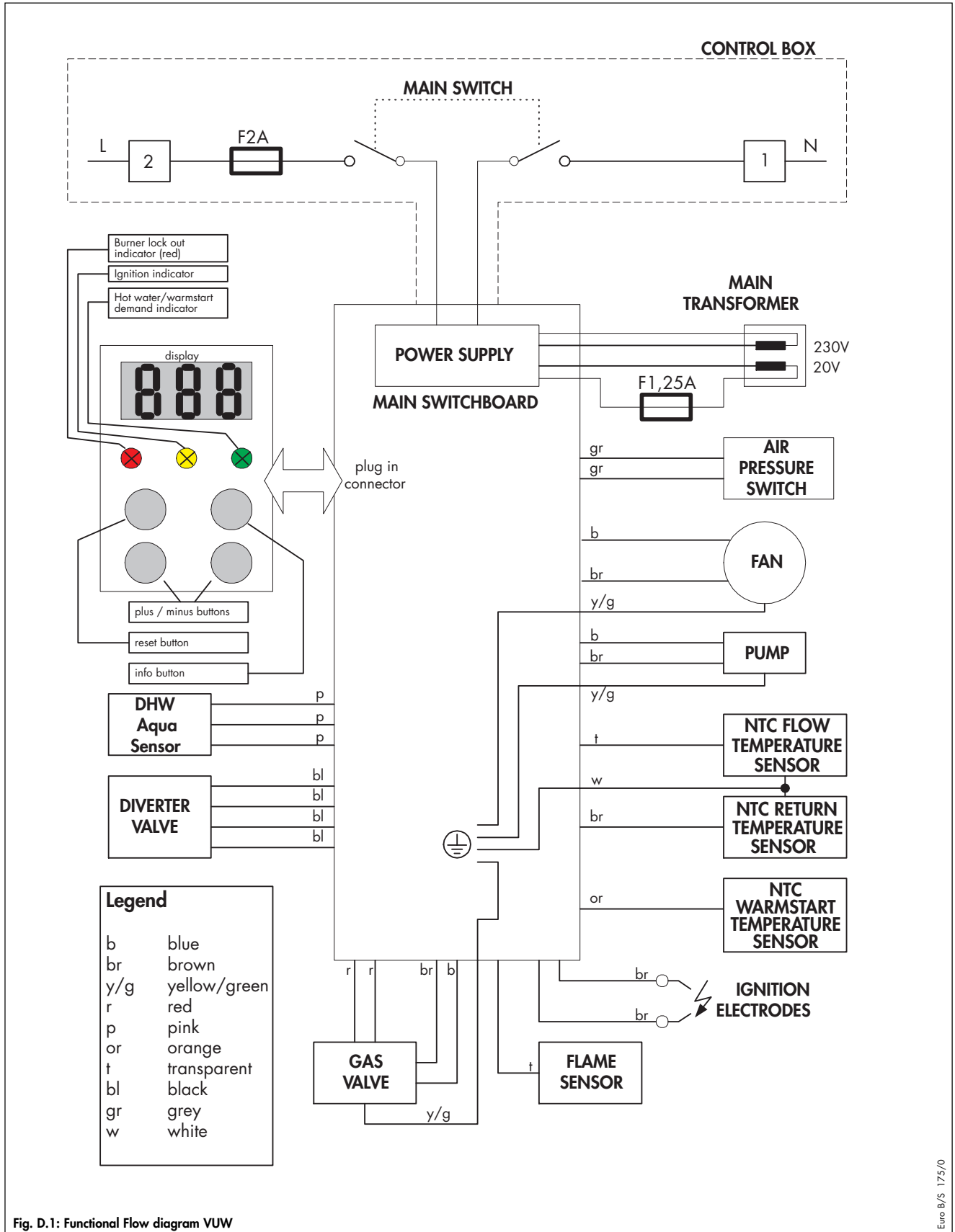
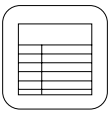

Fig. D.1: Functional Flow diagram VUW



DIAGRAMS

Functional Flow diagram: THERMOcompact 615/2 E, 620/2 E, 624/2 E, 628/2 E

THERMOcompact

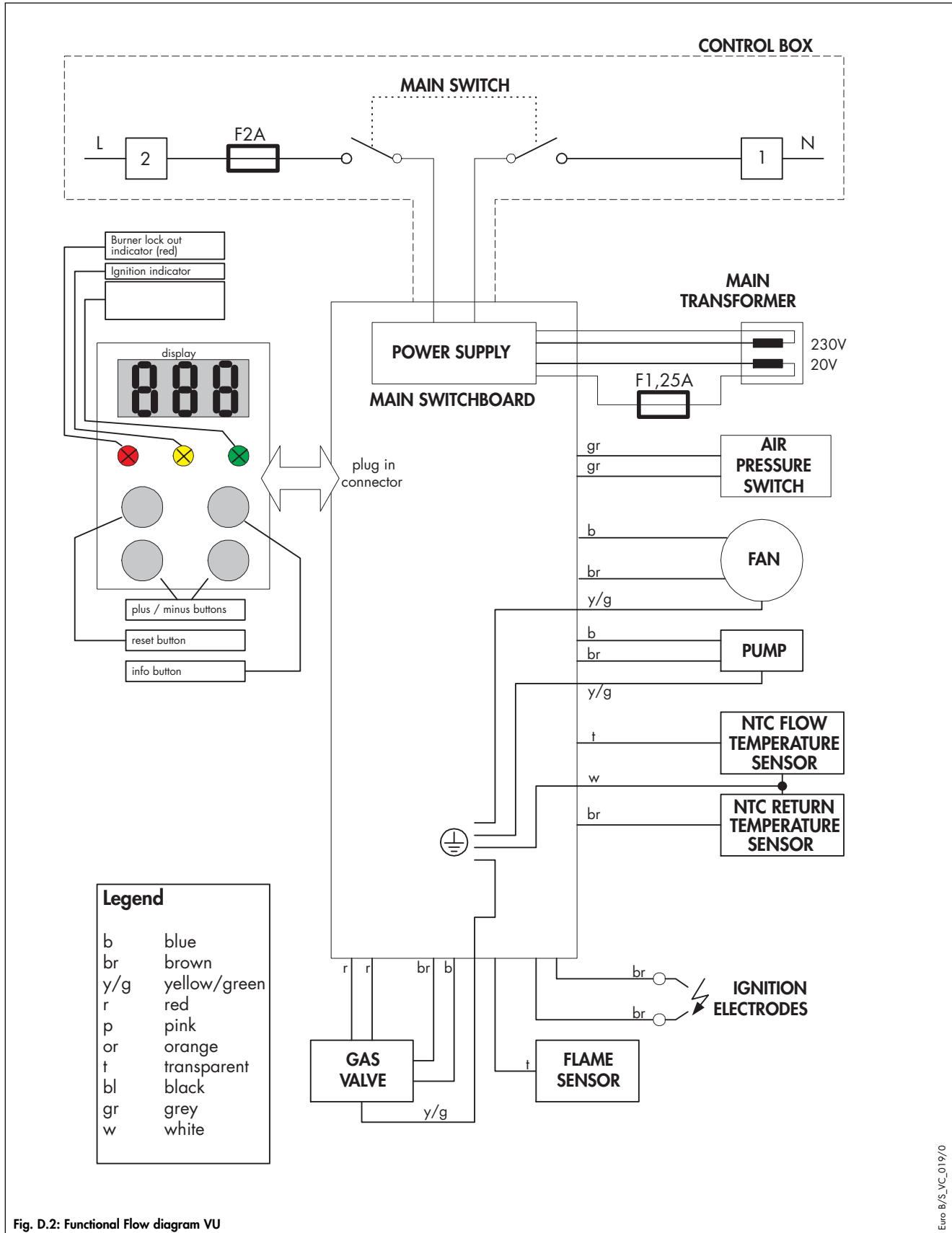

Euro B/S_YC_019/0

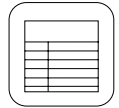

Wiring diagram: TURBOmax Plus 824/2 E, 828/2 E

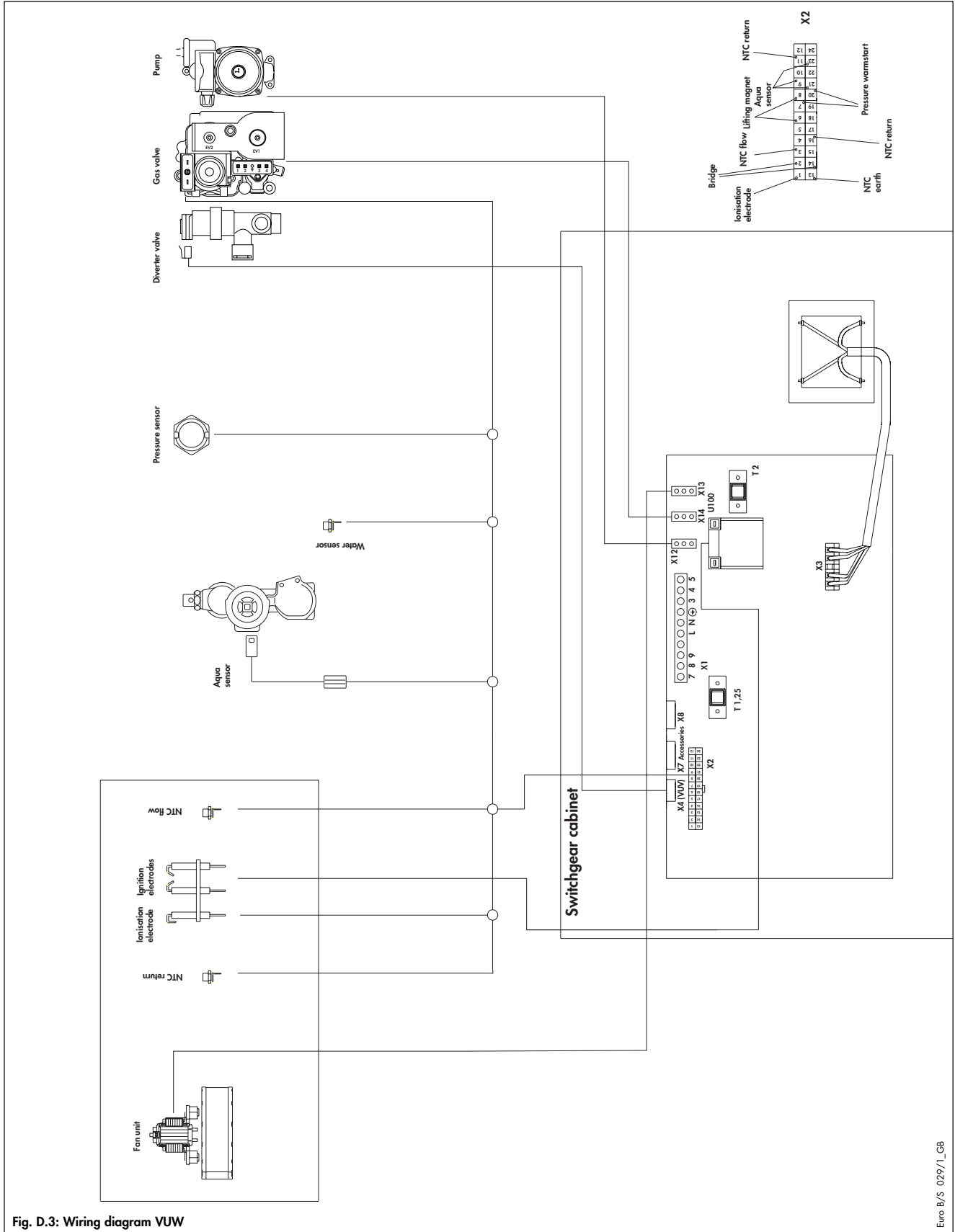

TURBOmax Plus

Fig. D.3: Wiring diagram VUW

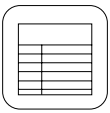

DIAGRAMS

Wiring diagram: THERMOcompact 615/2 E, 620/2 E, 624/2 E, 628/2 E

THERMOcompact

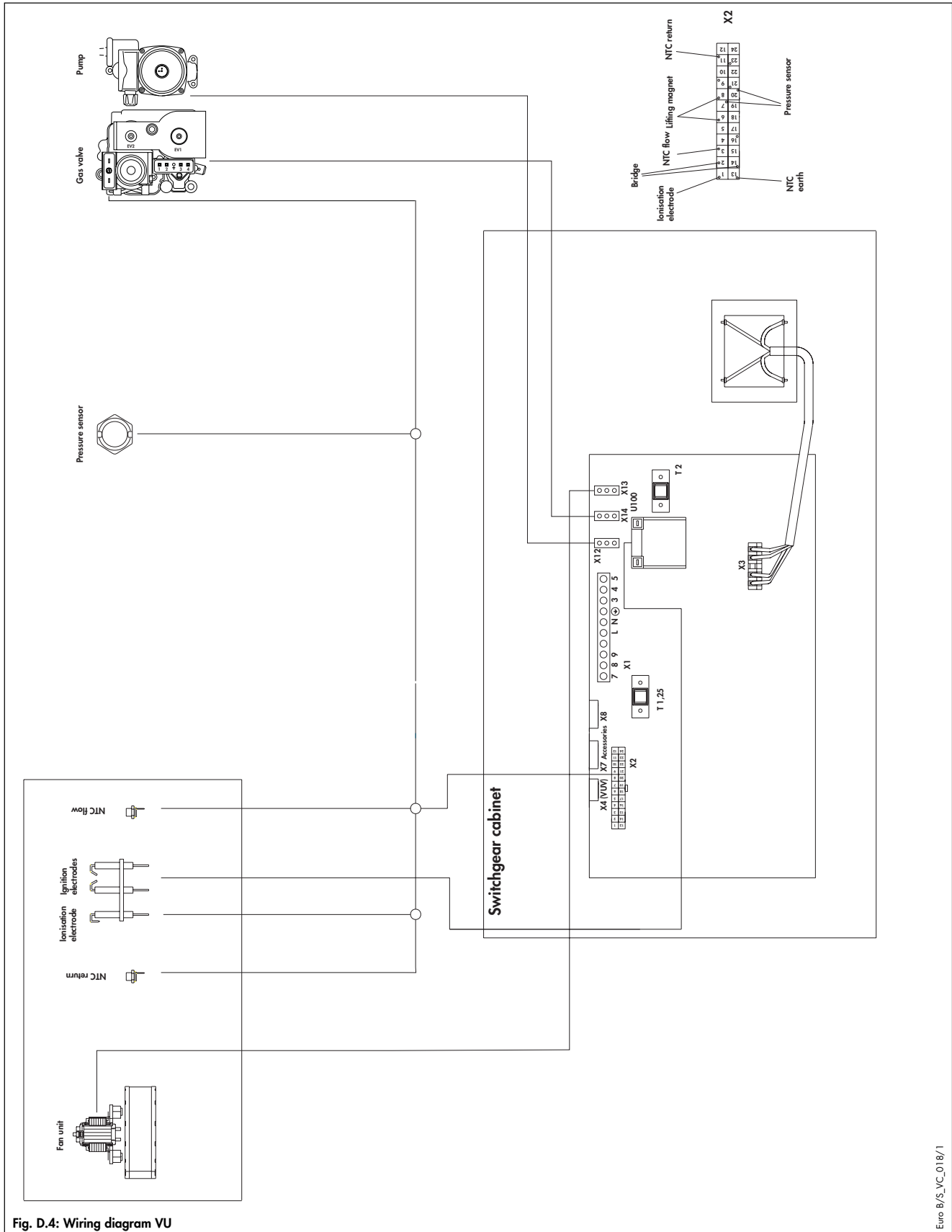

Fig. D.4: Wiring diagram VU

Euro B/S_YC_018/1

SHORT PARTS LIST



Description	Part No.	Key No.
Burner, natural gas	Burner chamber group 615E: 031508 Burner chamber group 620E: 031509 Burner chamber group 624E/824E: 031500 Burner chamber group 628E/828E: 031501 Distributor tube 615E: 126762 Distributor tube 620E: 126751 Distributor tube 624E/824E: 126752 Distributor tube 628E/828E: 1267523	Er.1
Ignition electrode Flame sensing electrode	090724	Er.2
Fan	190215	Er.3
Gas valve	LPG: 053499 Natural gas: 053473	Er.4
Flow-NTC Return-NTC Warmstart-NTC*	252805	Er.5
Main heat exchanger	615E: 065098 620E: 065098 624E/824E: 065086 628E/828E: 065087	Er.6
Expansion vessel	10 l: 181057	Er.7
Switch and control board	130474	Er.8
Main transformer	287450	Er.9
Pump	160928	Er.10
Air pressure switch	050577	Er.11
Automatic bypass	150240	Er.12
Diverter valve*	252457	Er.13
Pressure gauge	101271	Er.14
Aqua sensor*	194819	Er.15
DHW heat exchanger*	065088	Er.16
Pressure relief valve	190732	Er.17

* TURBOmax Plus only



SHORT PARTS LIST

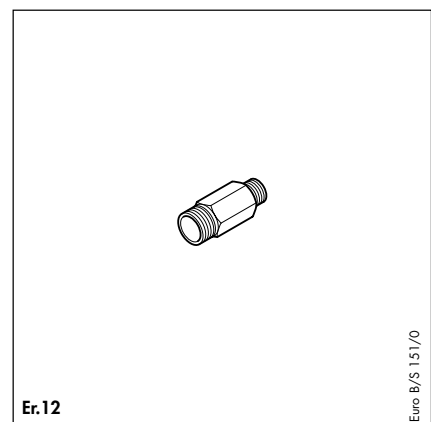
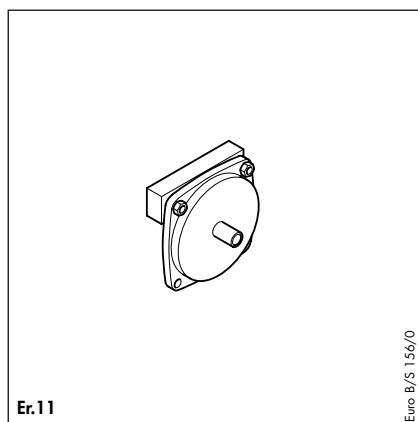
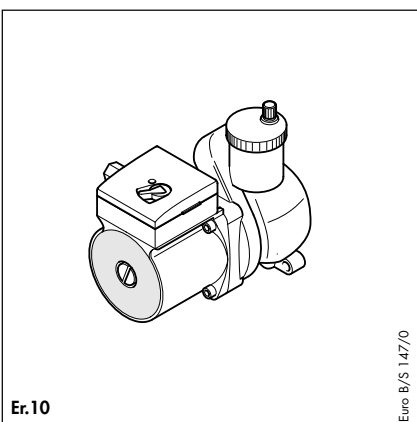
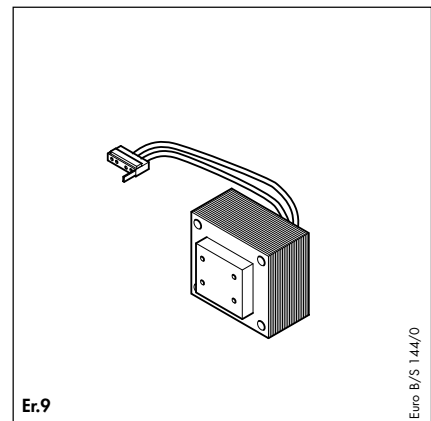
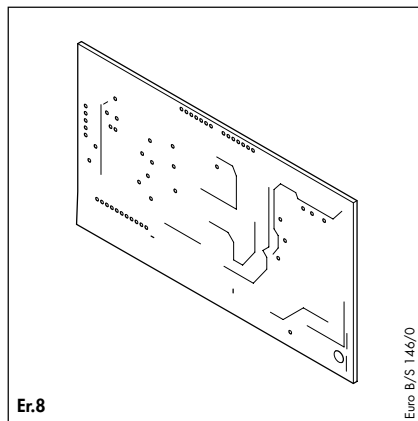
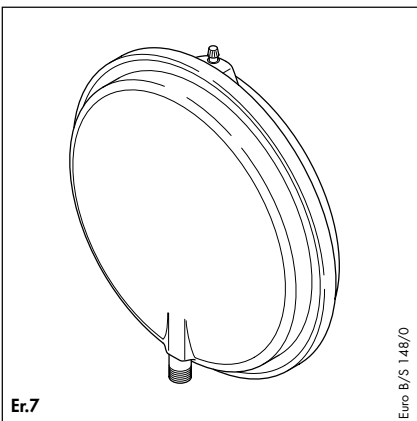
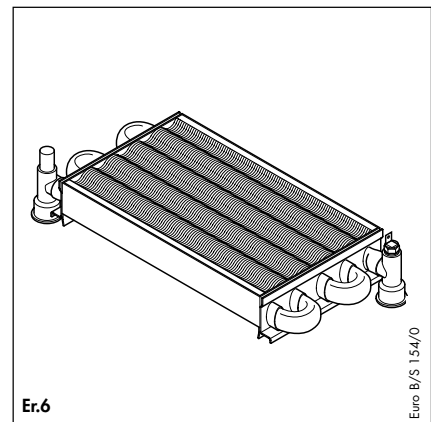
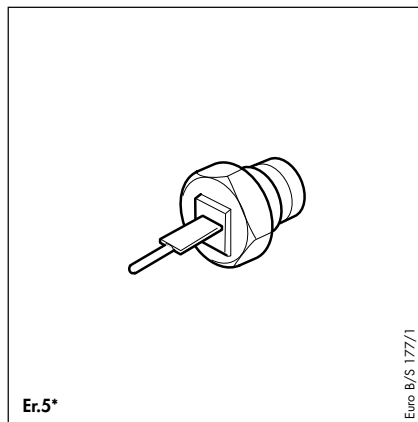
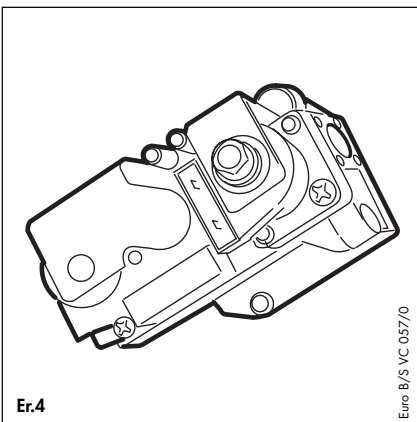
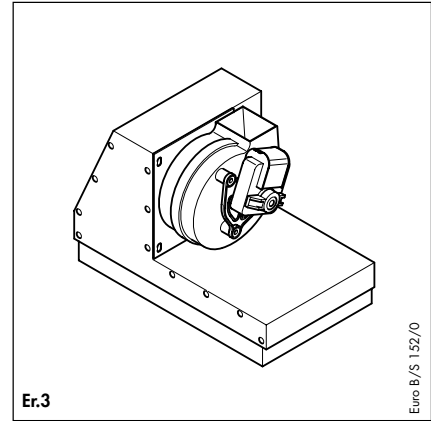
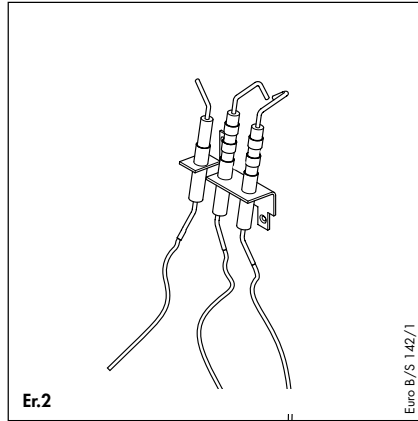
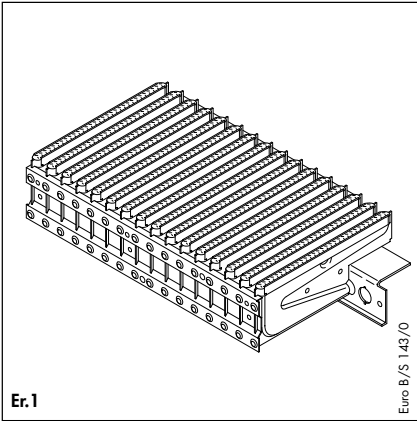

SHORT PARTS LIST

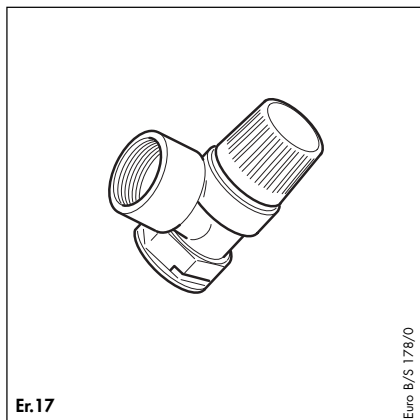
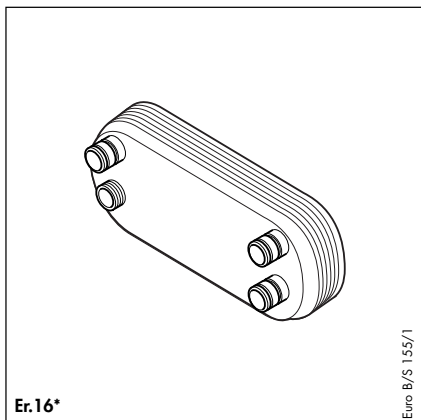
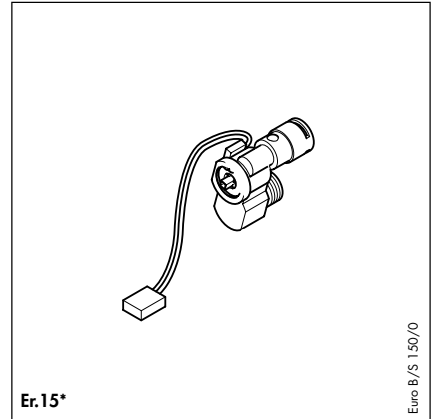
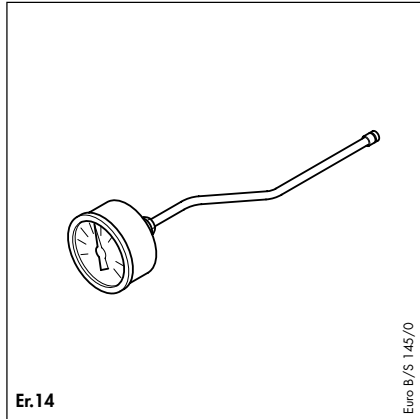
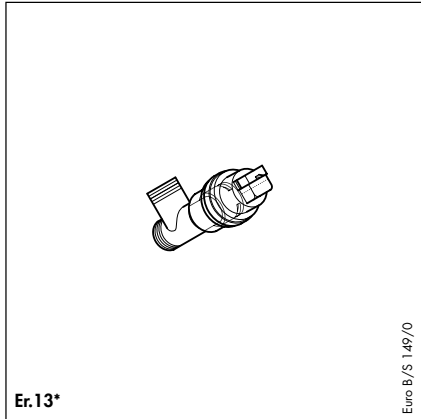

* TURBOmax Plus only



Head Office
Vaillant Ltd., Vaillant House,
Medway City Estate, Trident Close,
Rochester, Kent ME2 4EZ

Service Solutions 0870 6060 777
Technical Advice 01634 292392