



VistaMAX OBR3650HP Outdoor Base Station Transceiver

Installation and Operation Guide



Document: **OBR3650HP_ml_r01_sd**
Approved: **C.W.**

Proprietary to Vecima Networks Inc.

(C) Vecima Networks Inc., 2009

Permission to Reproduce

Except as otherwise specifically noted, the information in this publication may be reproduced, in part or in whole and by any means, without charge or further permission from Vecima Networks Inc., provided that due diligence is exercised in ensuring the accuracy of the information reproduced; that Vecima Networks Inc. is identified as the source; and that the reproduction is not represented as an official version of the information reproduced.

This publication is also available electronically on the World Wide Web at the following address:
www.vecima.com

Vecima Networks Inc. reserves the right to revise this publication and to make changes in content from time to time without obligation on the part of Vecima Networks Inc. to provide notification of such revision or change.

Vecima Networks Inc. provides this guide without warranty of any kind, either implied or expressed, including, but not limited to, the implied warranties of merchantability and fitness for a particular purpose. Vecima Networks Inc. may make improvements or changes in the product(s) described in this manual at any time.

Specifications subject to change without notice.

Contents

- Contents..... 1-1
- Preface..... I-i
 - Warnings and Advisories..... I-i
 - Regulatory Notices..... I-ii
 - Getting Support..... I-iii
 - Finding Related Documentation I-iii
 - Technical Support I-v
 - Warranty and Service Policies I-vi
- 1.0 Introduction..... 1-1
 - 1.1 OBR3650HP Overview 1-1
 - 1.2 Specifications..... 1-2
- 2.0 Installation..... 2-1
 - 2.1 Unpacking the Unit 2-1
 - 2.2 Mounting the OBR3650HP 2-1
 - 2.2.1 Water Proof the Connection..... 2-6
 - 2.3 Installing the Grounding Apparatus 2-7
 - 2.3.1 Lightning Protection 2-7
 - 2.3.2 Power Surge Protection..... 2-9
 - 2.3.3 Grounding the Base Station 2-10
- 3.0 Getting Started with OBR3650HP 3-1
 - 3.1 Before You Begin..... 3-1
 - 3.2 Overview of Configuration..... 3-2
 - 3.3 Using the Web Based Interface..... 3-3
 - 3.4 Configuring the Network..... 3-4
 - 3.5 Configuring the Radio..... 3-7
 - 3.6 Establishing a Link..... 3-9
 - 3.7 Other Administrative Tasks..... 3-10
 - 3.7.1 Upgrading the Base Station 3-10
 - 3.7.2 Adding a Virtual IP Address 3-12
 - 3.7.3 Rebooting the system..... 3-12
 - 3.7.4 Applying Configuration..... 3-13
 - 3.7.5 Resetting Configuration 3-13
 - 3.7.6 Checking Base Station Logs 3-14
 - 3.7.7 Viewing SNMP Log 3-14
 - 3.7.8 Setting Service Flow Information 3-15

3.7.9 SNMP Configuration.....	3-20
3.7.10 Subscriber Station Modulation Table.....	3-20
3.7.11 Checking Base Station Status.....	3-20
3.7.12 SS Table	3-21
3.7.13 PKM AUTH Table	3-21
3.7.14 PKM TEK Table.....	3-21
A1 Molex® Backshell Installation.....	A-1
A1.1 Molex® Backshell Components	A-2
A1.2 Initial Placement of the Backshell.....	A-3
A1.3 Attaching the RJ45 Connector.....	A-4
A1.4 Completing the Backshell Installation.....	A-7
B1 Installing the Antenna - Points to Consider	B-1
B1.1 Planning the Installation.....	B-1
B1.2 Safety Considerations.....	B-1
B1.3 Evaluating the Mounting Location.....	B-1

Preface

Warnings and Advisories



CAUTION

Before installing and operating this equipment, read all safety, installation and operating sections. Retain this manual for future reference. Follow all instructions - failure to do so may result in damage to the unit or severe personal injury.



CAUTION

Servicing should not be attempted by the user. There are no user serviceable parts inside. Refer all servicing to factory qualified personnel.



CAUTION

To comply with RF exposure requirements, the integrated antenna or any external antenna which is connected to an OBR3650HP requires a minimum distance of 1.5 meters between it and all persons.

Regulatory Notices

FCC Compliance

This equipment has been tested and found to comply with the limits for Class B Digital Device, pursuant to Part 15 of the FCC Rules. These limits are designed to provide reasonable protection against harmful interference in a residential installation. This equipment generates and can radiate radio frequency energy and, if not installed and used in accordance with the instructions, may cause harmful interference to radio communications. However, there is no guarantee that interference will not occur in a particular installation. If this equipment does cause harmful interference to radio or television reception, which can be determined by turning the equipment off and on, the user is encouraged to try to correct the interference by one or more of the following measures.

- Reorient or relocate the receiving antenna
- Increase the separation between the equipment and receiver
- Connect the equipment into an outlet on a circuit different from that to which the receiver is connected
- Consult the dealer or an experienced radio/TV technician for help

To reduce potential radio interference to other users, the antenna type and its gain should be so chosen that the equivalent isotropically radiated power (EIRP) is not more than that required for successful communication.

Industry Canada Compliance

Operation of this device is subject to the following two conditions:

- (1) this device may not cause interference, and
- (2) this device must accept any interference, including interference that may cause undesired operation of the device.

The users should not modify or change this device without written approval from Vecima Networks. Modification will void warranty and authority to use the device.

For safety reasons, people should not work in a situation where RF exposure limits could be exceeded. To prevent this situation, the users should consider the following rules:

- Install the antenna so that there is a minimum of 23 cm (9.06 in) of distance between the antenna and people.
- Do not turn on power to the device while installing the antenna.
- Do not connect the antenna while the device is in operation.
- Do not collocate or operate the antenna used with the device in conjunction with any other antenna or transmitter.
- In order to ensure compliance with local regulations, the installer **MUST** enter the antenna gain at the time of installation.

Any changes or modification to said product not expressly approved by Vecima Networks voids the user's authority to operate this device.

The Vecima OBR3650HP base station unit must be installed by a trained professional, value added reseller, or systems integrator who is familiar with RF cell planning issues and the regulatory limits defined by Industry Canada for RF exposure.

Getting Support

Finding Related Documentation

The user manuals for the VistaMAX series of products may be downloaded from our FTP site as follows:

Step 1 Using a web browser, visit <https://files.vecima.com>

Step 2 Select 103 from the 'Jump to Download Area' drop menu and click on 'Go!'



Private Download Area

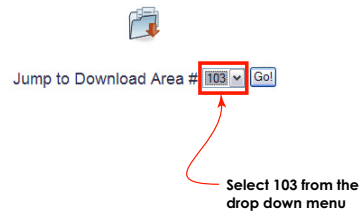

Step 3 Enter the Username as **vistamax** and the Password as **vistamax**

Index of /private_dl/103

Name	Last modified	Size	Description
Parent Directory		-	
Document full names ..>	18-Jun-2008 11:08	456	
nms8000_ml_01_sd.pdf	16-Feb-2007 13:14	13M	
obr3500_ml_02_sd.pdf	27-Jun-2008 14:58	8.0M	
obr3650_ml_01_sd.pdf	27-Jun-2008 14:30	8.6M	
opc3500_ml_01_sd.pdf	29-Jun-2007 09:28	9.0M	
osr3500_ml_02_sd.pdf	06-Jul-2007 16:11	7.0M	
wes800_ml_04_sd.pdf	17-Dec-2007 11:47	2.5M	

Apache/2.0.54 (Ubuntu) mod_python/3.1.3 Python/2.4.2 PHP/4.4.0-3ubuntu2 proxy_html/2.4 mod_ssl/2.0.54 OpenSSL/0.9.7g Server at postoffice Port 443

Step 4 Download the required file(s)

Document Conventions

This manual uses the following special formats to emphasize key information. Be aware of all warnings and cautions before you begin to install the OBR3650HP.



WARNING

Whenever you see this icon and heading, the associated text addresses or discusses a critical safety or regulatory issue.



CAUTION

Whenever you see this icon and heading, the associated text discusses an issue, which, if not followed, could result in damage to, or improper use of, the equipment or software.



NOTE

Whenever you see this icon and heading, the associated text provides some important information not directly related to the topic.



TIP

Whenever you see this icon and heading, the associated text provides a tip for facilitating the installation, testing, or operation of the equipment or software

Technical Support

Visit the Vecima Networks Web page at www.vecima.com.

- Get the latest announcements from Vecima Networks.
- Download product related software, manuals, application notes, or other information about Vecima products.

For technical support:

Contact technical support by telephone or email.

- Email: support@vecima.com
- Telephone: +1 306 955 7075, press "2" for technical support.

Be prepared to provide your model number and phone number.

Warranty and Service Policies

Warranty Statement

Vecima Networks warrants its products to be free from defects in workmanship or materials for a period of two years. The warranty begins on the date of the original shipment from Vecima Networks to its customer. No claim may be allowed for expenses incurred in installation or use. No other expressed or implied warranties shall apply to the goods sold. Vecima Networks is not responsible for delayed shipments, other loss beyond Vecima Networks' control, or consequential damages of any kind arising in connection with the use of its products. This warranty is a return-to-factory warranty only. During the warranty period Vecima Networks will at its option, replace, repair or refund the price paid for any item which is returned for service. This warranty does not apply to units that have been misused physically or used in an inappropriate environment.

Service Policies

Return Material Authorization

Before returning any item for service, you must obtain a Returned Material Authorization (RMA) number from Vecima Networks. Vecima Networks will assign a unique RMA number for each item returned.

How to Return an Item for Service

- Step 1** Contact Vecima Networks to obtain an RMA number. Before contacting Vecima Networks, record the model number, Vecima serial number, original invoice number, purchase order number, and a description of the fault. Vecima will request this information before providing an RMA.



Email: support@vecima.com

Telephone: +1 306 955 7075, press "2" for technical support.

- Step 2** Refer to the RMA number in all correspondence and clearly mark all applicable RMA numbers on the outside of each package returned.
- Step 3** The repair center will provide you with shipping instructions when they send the RMA number to you.
- Step 4** Ship each product to Vecima Networks in its original shipping container (or equivalent) via prepaid carrier, with appropriate insurance and customs documentation (where required). Vecima Networks will not accept collect shipments, damaged shipments or shipments unaccompanied by an RMA number.
- Step 5** Vecima Networks will replace or repair items and return them to you as follows:

For items still under warranty—Vecima Networks Inc. will return items via prepaid ground carrier. The customer is responsible for any additional costs incurred, including customs clearance and duties. The customer will be responsible for any additional charges incurred from alternative shipping methods.

For items no longer under warranty—Vecima Networks will return items via prepaid ground carrier at the customer's expense. The customer is responsible for any additional costs incurred, including customs clearance and duties. The customer will be responsible for any additional charges incurred from alternative shipping methods.

Repair Charges and Warranty Exemptions

Items returned beyond the warranty period or items that do not qualify for warranty service are subject to additional out-of-warranty repair charges. Descriptions of these charges and warranty exemptions are listed below:

- (1) Repair turnaround time is typically 5-14 business days after receipt of the item at Vecima Networks. A flat rate repair charge will apply to all out-of-warranty items. Flat rate repair charges are subject to change without notice.
- (2) Any faults due to customer error (i.e. - incorrect set-up or configuration settings) are subject to the current test fee and will be exempt from warranty.
- (3) Items returned with inadequate fault descriptions are subject to the current test fee and are exempt from warranty.
- (4) In the event that no fault is found, the item is subject to the current test fee and will be exempt from warranty.
- (5) Any product exhibiting external damage (either from shipping, improper handling or use) will be subject to inspection. If said damages are determined to be the cause of failure, the item will be exempt from warranty. All repairs to correct the external damage are subject to time & materials charges (parts and labor at current rates).
- (6) Items with damage caused by unauthorized repairs or by external devices are subject to current out-of-warranty flat rate repair charges and are exempt from warranty.
- (7) All products returned for factory optioning are subject to the applicable current option charge plus test fee. Factory-optioned products carry the balance of the original warranty or a 90 day warranty, whichever is greater.



NOTE

The customer must approve all out-of-warranty repairs in writing. Vecima will not start any repairs until they receive the customer's purchase order or out-of-warranty repair authorization.

This page intentionally left blank

1.0 Introduction

1.1 OBR3650HP Overview

The VistaMAX Outdoor Base Station 3650 (OBR3650HP) is a WiMAX compliant low power transceiver with an integrated 60, 90, or 120 degree antenna contained in a weatherproof sealed housing. The OBR3650HP offers a single out-of-box solution for WiMAX applications – the only equipment required inside the base station premises is Power over Ethernet switch. The OBR3650HP is part of the WiMAX compliant VistaMAX family of base stations, subscriber units, and network equipment available from Vecima Networks.

The OBR3650HP operates in the 3650 to 3675 MHz band. It requires an additional indoor Power over Ethernet switch such as the VPN100002. The WiMAX Ethernet Switch 800 (WES800) can also serve as the Ethernet switch to provide power to sectors using the units and serve as the network connection point.



Figure 1-1 VistaMAX OBR3650HP

1.2 Specifications

RF

Item	Specification
RF Frequency	3650 to 3675 MHz
RF Frequency Step Size	250 KHz
Duplexing Mode	TDD
Channel Bandwidth	3.5 MHz or 7 MHz (software selectable)
Modulation Types	IEEE 802.16-2004, OFDM256, burst by burst adaptive BPSK-1/2 QPSK-1/2, QPSK-3/4 16QAM-1/2, 16QAM-3/4 64QAM-2/3, 64QAM-3/4
Maximum Rated Power	+27dBm at the external antenna connector
Output Power	+17 dBm to +27 dBm
Output Power Control Range	FCC Part 90
Spectral Mask Compliance	-94 dBm
Minimum Sensitivity	-91 dBm
Integrated Antenna Options	N female

Network

Item	Specification
LAN Interface	10/100BaseT 802.3 Ethernet
Management/Monitoring Interfaces	SNMP (WiMAX Forum MIBs + Vecima Networks extensions) Built-in HTTPS web server Telnet/SSH CLI Syslog

Operation Parameters

Item	Specification
Lightning Protection	Multi-strike protection built-in
Power Supply	36 to 56 VDC Power over Ethernet
Power Consumption	45 W maximum

Mechanical

Item	Specification
Operating Temperature	-45°C to +55°C
Physical	20" x 8" x 5" (50.8cm x 20cm x 12.7cm) maximum
Mounting	Pole mount (2.5" to 4.5" diameter pole)
Weight	20 lbs. (9 kg) maximum
Weatherproofing	NEMA 4X/IP66

2.0 Installation

2.1 Unpacking the Unit

Carefully remove the equipment from the packing material and set it on a solid surface, such as a table or desk. If it appears damaged in any way, notify the carrier and keep all packing materials for inspection by the carrier's agent.

2.2 Mounting the OBR3650HP

The following hardware is included in the box for mounting the OBR3650HP to the pole:

- Qty. 1 x Chassis Bracket
- Qty. 1 x Elevation Adjustment Bracket
- Qty. 1 x Pole Catch Bracket
- Qty. 4 x 6 inch Carriage Bolts
- Qty. 8 x Nuts
- Qty. 4 x Split Lock Washer
- Qty. 4 x Bolts
- Qty. 4 x Flat Washer
- Qty. 4 x Nylon Washer

The Chassis Bracket and Elevation Adjustment Bracket come pre-installed on the OBR3650HP chassis.

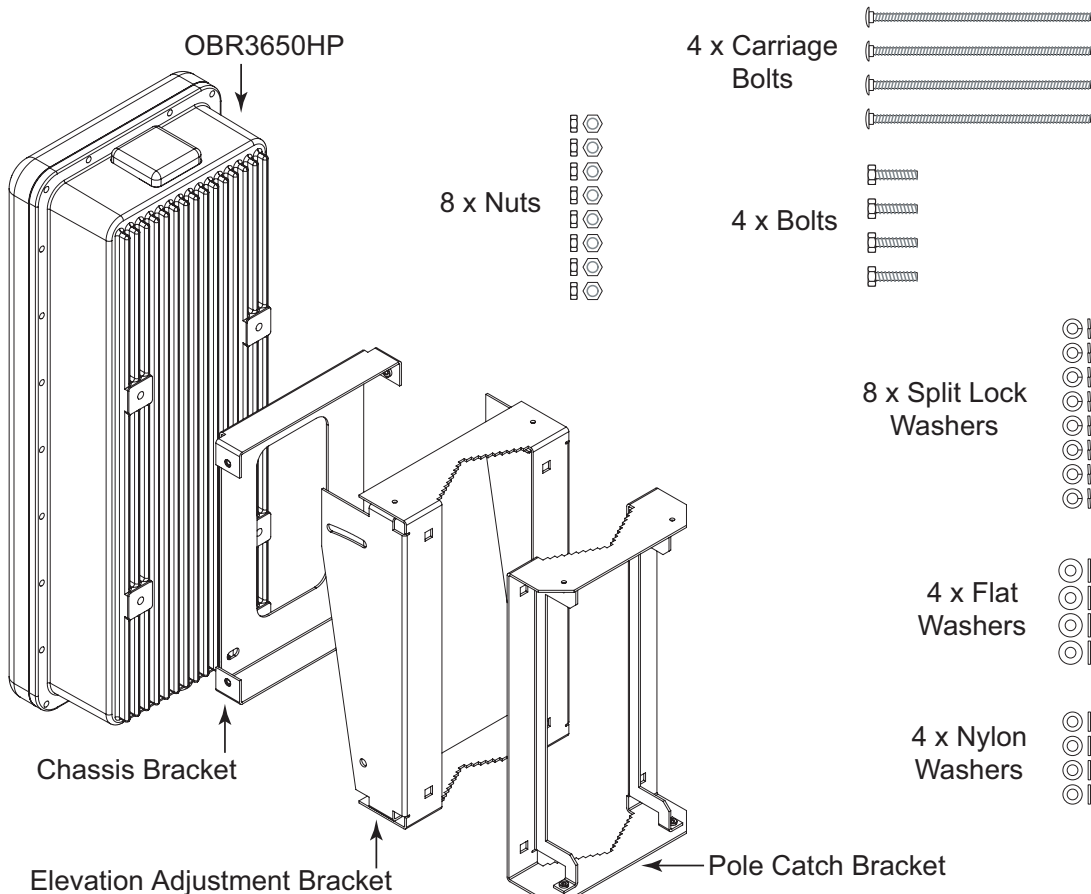
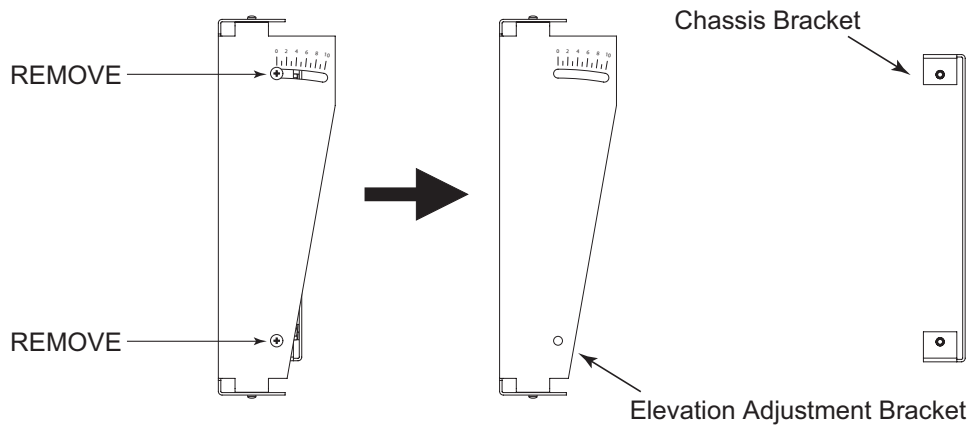

Figure 2-1 OBR3650HP Pole Mounting Hardware

Figure 2-2 & 2-3 describe the steps necessary to prepare the OBR3650HP for pole mounting.

- 1 Remove the Elevation Adjustment Bracket from the Chassis Bracket by removing the four screws (2 on each side).



- 2 Attach the Chassis Bracket to the OBR3650HP using four bolts and assorted washers as shown below. Take care to place the nylon washers between the Chassis Bracket and the OBR3650HP to prevent damage to the paint.

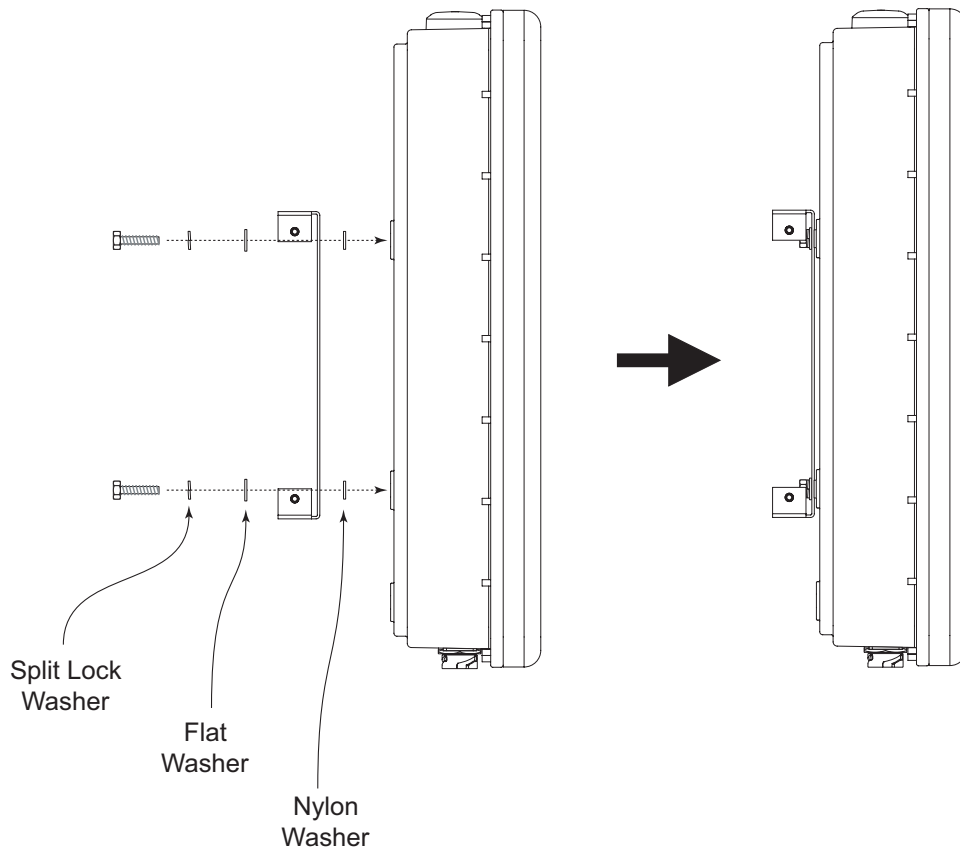
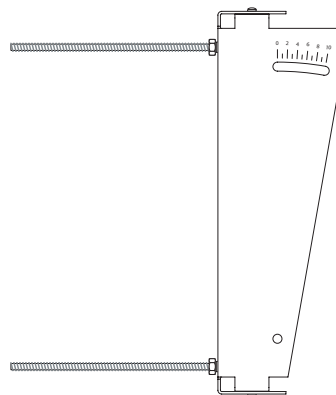
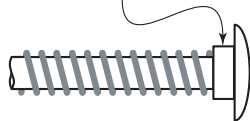

Figure 2-2 Preparing the OBR3650HP for Pole Mounting (Part 1)

3 Insert the four carriage bolts into the four square holes in the Elevation Adjustment bracket as shown

To prevent the square collar near the head of the carriage bolts from slipping back through the square holes, fasten a nut onto each carriage bolt as shown -- **NOTE:** do not use any washers; the nuts will not fasten flush to the surface. The nuts will prevent the square collars on the carriage bolts from slipping out of the notches when fastened down.

Square collar on carriage bolt



Elevation Adjustment bracket with Carriage bolts installed (viewed from the side)

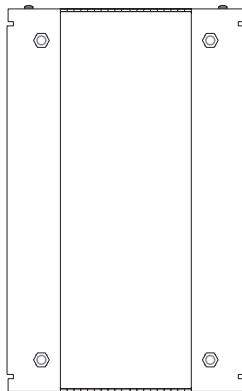

Elevation Adjustment bracket with Carriage bolts installed (viewed from the "face" that will mount against the pole)

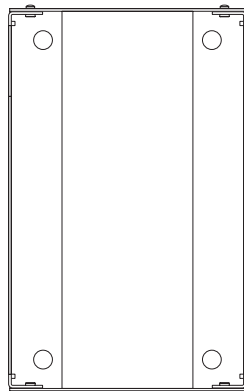

Elevation Adjustment bracket with Carriage bolts installed (viewed from the "face" that will mount towards the OBR3650HP)

4 After inserting the carriage bolt into the Elevation Adjustment bracket, re-attach the bracket to the OBR3650HP by replacing the four screws (2 on each side) as shown.

The OBR3650HP is now ready to be mounted to a pole.

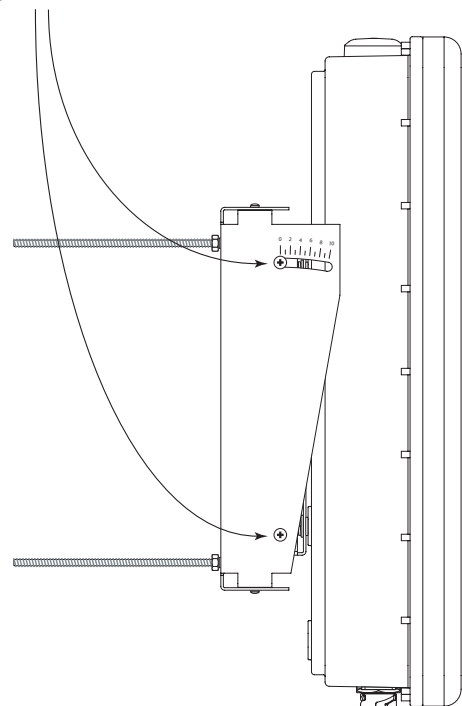
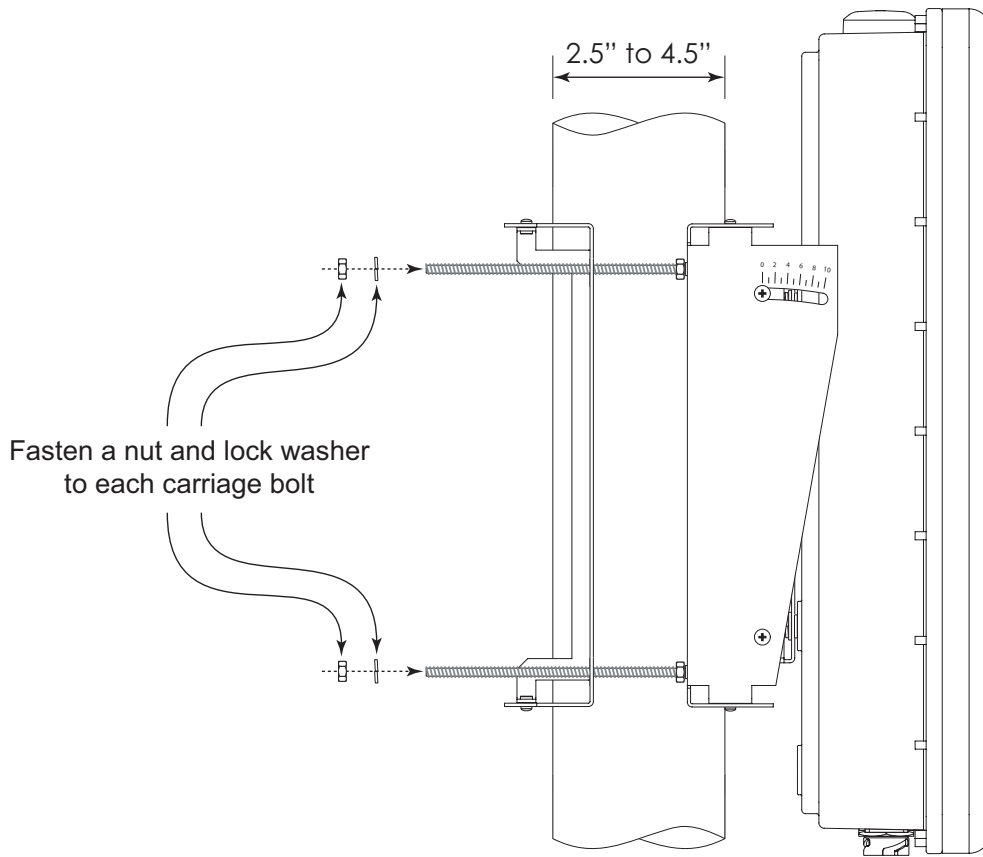
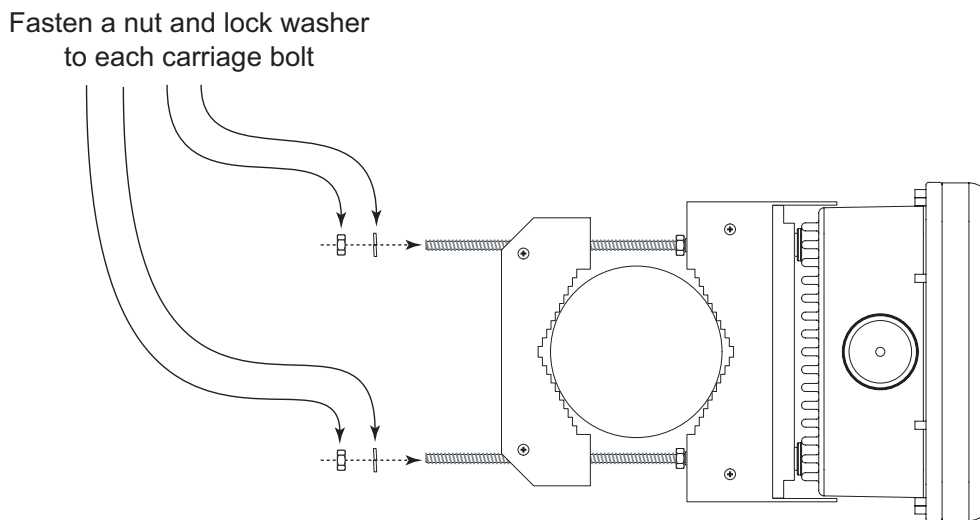

Figure 2-3 Preparing the OBR3650HP for Pole Mounting (Part 2)

After preparing the OBR3650HP for pole mounting, hold the OBR3650HP against the pole at the desired height then place the Pole Catch Bracket onto the opposite side as shown in Figure 2-4. Fasten a lock washer and nut onto all four carriage bolts and tighten until the OBR3650HP is suitably secured in place.



Pole Mounting - Side View



Pole Mounting - Top View

Figure 2-4 Attaching the OBR3650HP to the Pole

Once the OBR3650HP is mounted to the pole, the Elevation Angle may be adjusted as necessary and the unit may be connected to the network via a CAT5E cable with a standard RJ45 connector on one end and a special Molex® backshell with RJ45 connector on the other end.

NOTE

If not using a pre-made cable assembly (such as a CAT5CABLE/OD/25, CAT5CABLE/OD/50, CAT5CABLE/OD/75 or CAT5CABLE/OD/10 from Vecima Networks), then a cable assembly will have to be made using the Molex® backshell included with the OBR3650HP. Please see Appendix 1 for details on how to install the Molex® backshell.

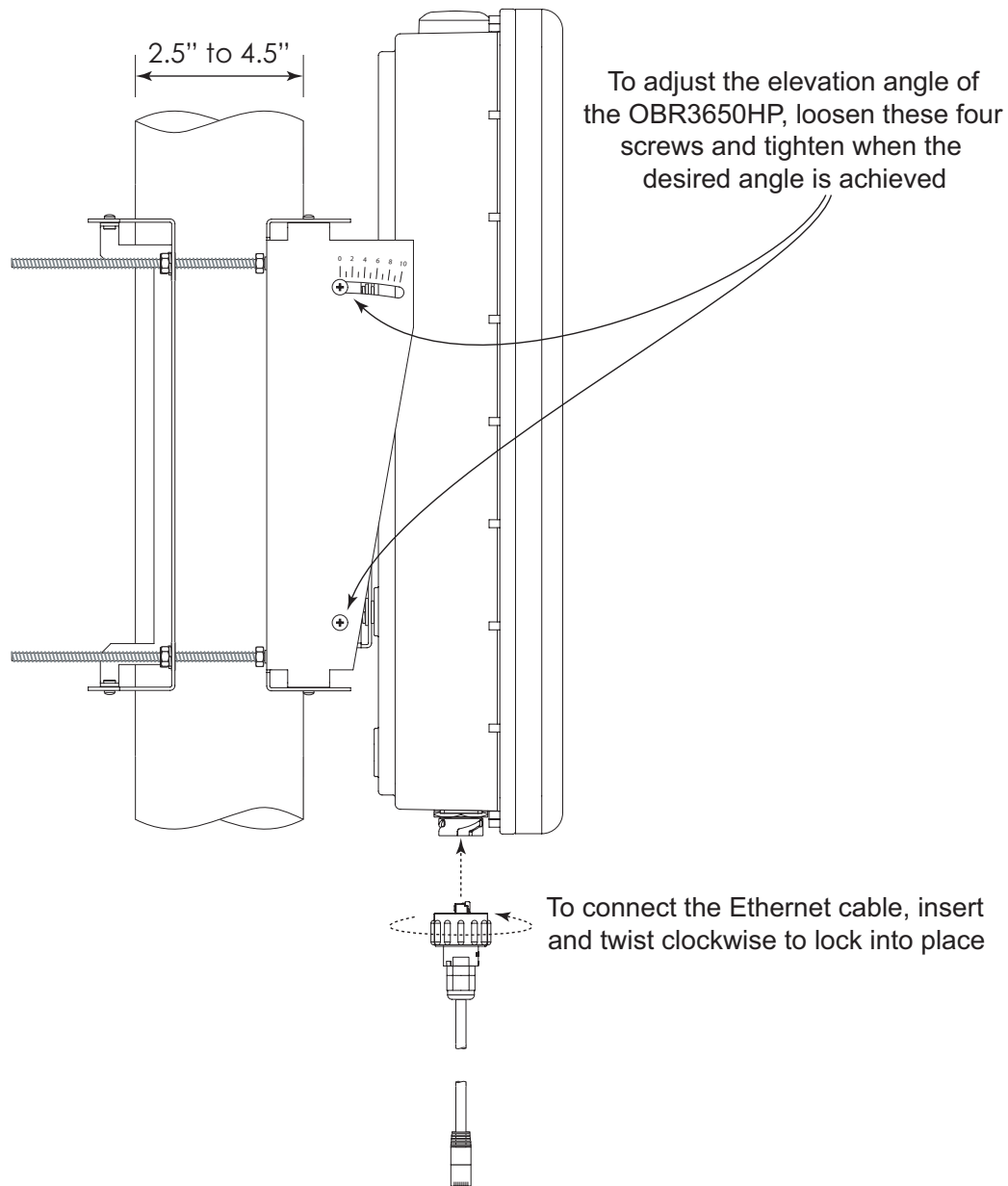

Connect the other end of the Ethernet cable into the network via surge suppressor

Figure 2-5 Connecting the OBR3650HP to the Network

2.2.1 Water Proof the Connection

Wrapping the antenna connection with sealing tape keeps the connection tight and protects against moisture.

To water proof the connection follow these steps:

- Step 1** Use a section of rubber sealing tape. Starting at the OBR3650HP end, stretch the tape and wrap it around the connector as close as possible to the body of the OBR3650HP. Overlap the tape by approximately one-half of its width so that it can form a seal with itself. Extend the wrapping to approximately one-inch past the end of the connector.



Figure 2-6 Apply Rubber Sealing Tape

- Step 2** Cover the sealing tape with electrical tape. Start approximately one inch further down the cable, and stretch the tape, overlapping by one-half. Wrap to the OBR3650HP end, then without breaking the tape, wrap back down to the cable end.



Figure 2-7 Water Proofed Connection

2.3 Installing the Grounding Apparatus

Install the grounding apparatus to protect the OBR3650HP from lightning strikes and power surges. Ground the base station to the earth ground to protect from lightning strikes. Use the surge suppressor to shunt to ground any over-voltage [>60 V] transients that may be induced on the CAT5E cablefeed via lightning or other high voltages.

2.3.1 Lightning Protection

The OBR3650HP has a built in lightning surge suppression mechanism to protect it against damage from lightning strikes.

Assembling the OBR3650HP Base Station Grounding

Attach the earth ground to the grounding lug located on the base station.

Provided parts:

- 1 x 5/8 inch washer
- 1 x 1/4 inch grounding lug

Required parts:

- 1 x #6 AWG grounding wire assembly of sufficient length to connect the OBR to the tower's earth ground bus
- 1 Size 11 Wrench (11mm or 7/16 inch)

To assemble and attach the ground lug:

1. Locate the grounding point on the OBR3650HP. This is at the bottom of the OBR, to the right of the Vecima sticker.
2. On the grounding lug, assemble the grounding combination in the following order:
Lug > Washer > Grounding Assembly > Washer.
3. Screw the combination into the OBR at the grounding point.
4. Attach the assembly to the lightning grid or the antenna.

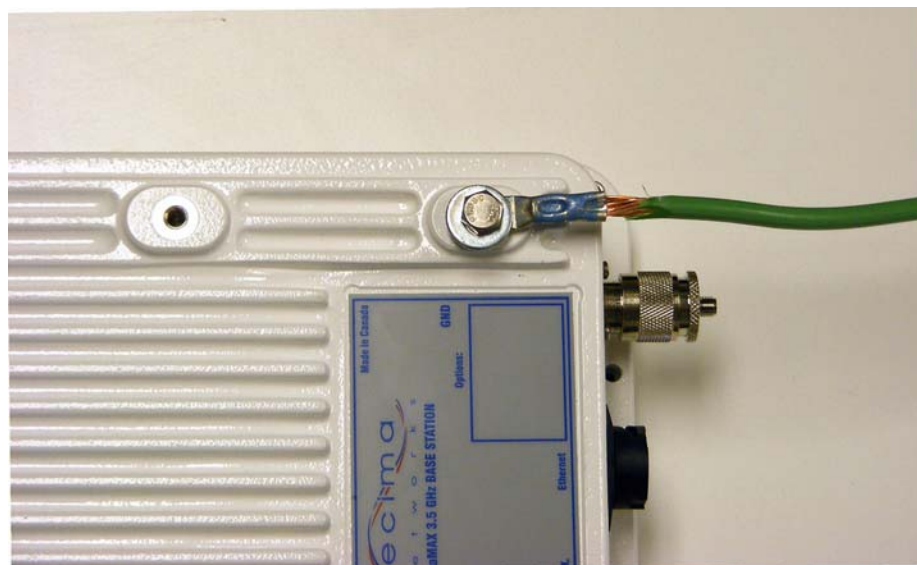

Figure 2-8 Assembled Ground Lug

Grounding the Base Station

Vecima Networks requires that the OBR3650HP be connected to the tower grounding system as shown in Figure 2-11.

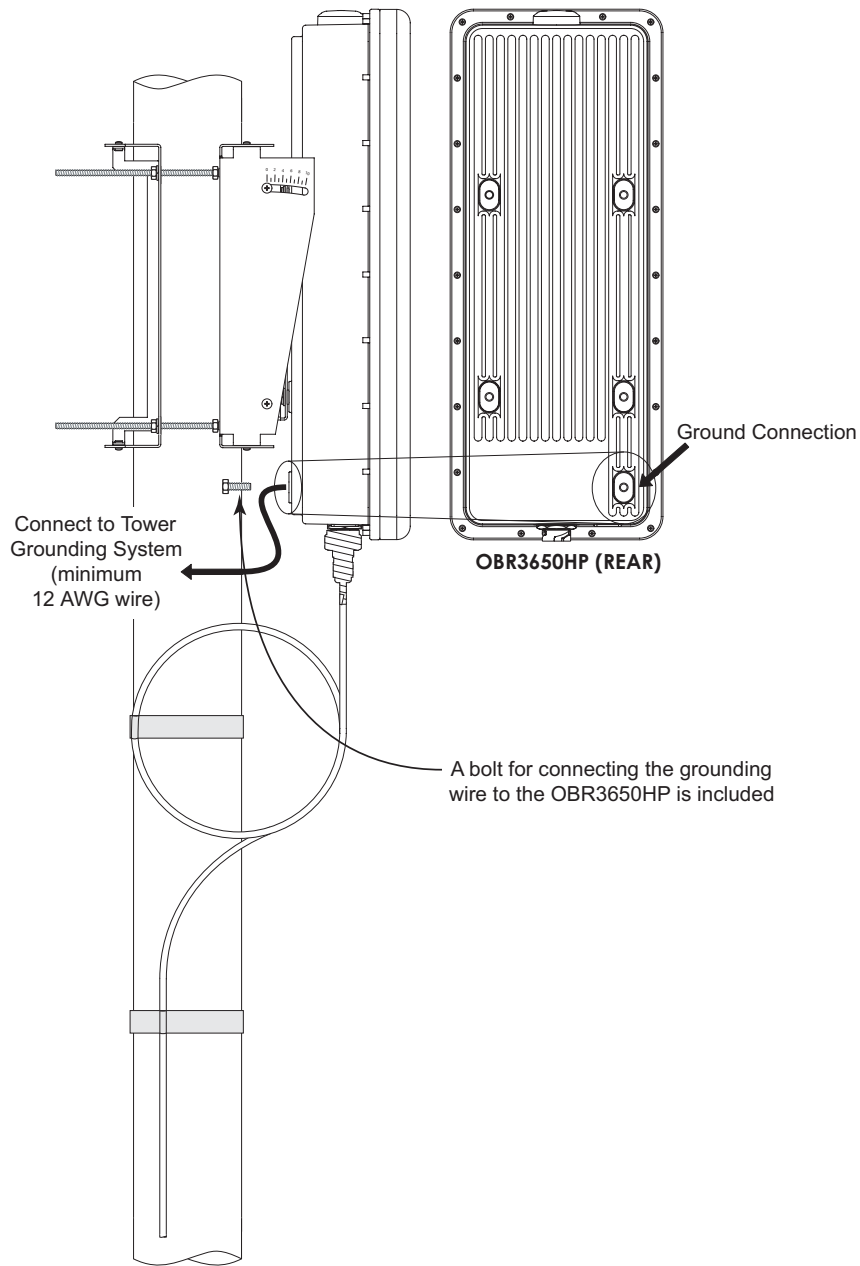

Figure 2-9 Grounding the OBR3650HP



CAUTION

Vecima Networks requires that the CAT5E cable to the OBR3650HP is connected to a lightning surge protector at the entrance to the building, prior to connection to the WES800 Ethernet Switch as shown in [Figure 2-10](#).

2.3.2 Power Surge Protection

Use the surge suppressor to protect your equipment and secure your data from power surges.

To connect the Cablefeed Shield to the Surge Suppressor Ground Lug

1. Remove the suppressor unit cover.
2. Thread the Ethernet cable through the right side opening to the suppressor.
3. Measure five (5) inches from the end of the cable that you threaded through the right side opening.
4. Lightly score the cable at the five inch mark.
5. Carefully slice the edge of the insulation.

Note: Do NOT cut the metal shield that surrounds the wires.

6. Slowly snip or slice the insulation down to the five (5) inch scoring.
 7. Remove the insulation from the cable.
 8. Gently twist the metal shield to form metal ground strip.
 9. Make a straight-through cable with the wires.
- Remember:** be careful not to damage the metal ground strip.
10. Undo the grounding bolt on the right side of the suppressor.
 11. Wrap the grounding strip onto the grounding bolt.
 12. Screw the grounding bolt back into the side of the suppressor.
 13. Thread the cable that connects to the Power over Ethernet through the left opening on the suppressor.
 14. Strip the wires and make it a straight-through cable.
 15. Connect the cables to their perspective ports.
 16. Replace the cover of the suppressor.
 17. Finish connecting the network. See “2.3.3 Grounding the Base Station”

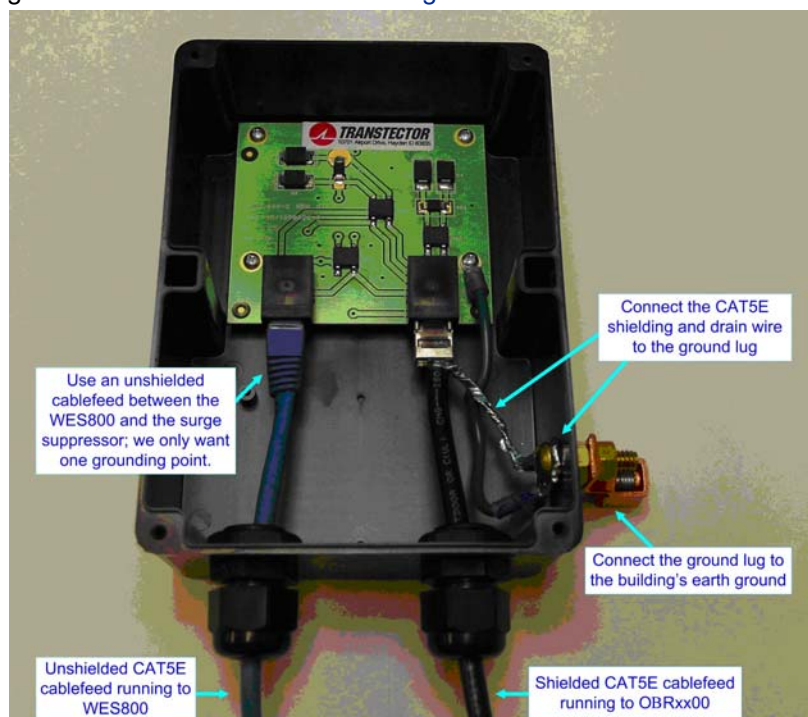

Figure 2-10 Assembled Surge Suppressor

2.3.3 Grounding the Base Station

Vecima recommends grounding the base station using one of the following procedures depending on your configuration. If you are unsure which procedure to use, use procedure B.

Procedure A: Grounding the base station so that the building and the tower share the same earth ground:

1. Connect the chassis of the OBR3650HP to the tower via the grounding lug on the back of the unit. See “2.3.3 Grounding the Base Station”.
2. Use a shielded CAT5 cablefeed to connect the OBR base station to the surge suppressor.
3. Use an inline surge suppressor for all OBR3650HP cablefeed installations. Connect the shield of the cablefeed to the ground lug of the surge suppressor. The purpose of the surge suppressor is to shunt to ground any over voltage [>60] transients that may be induced on the CAT5E cablefeed via lightning or other high voltages.

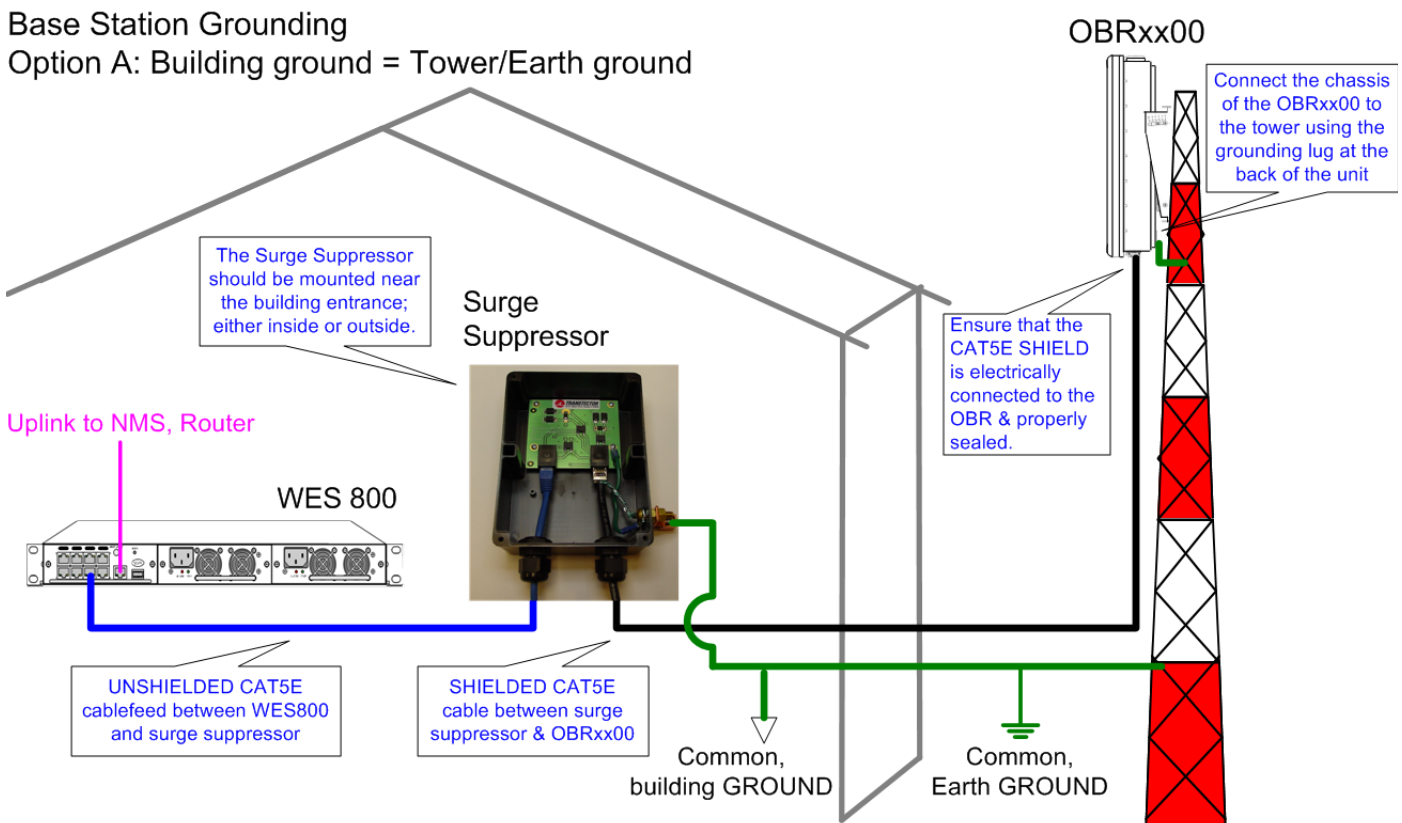

Figure 2-11 Base Station Grounding - building ground is same as tower ground

Procedure B: Grounding the base station so that the building and the tower use different earth grounds:

1. Connect the chassis of the OBR3650HP to the tower via the grounding lug on the back of the unit. See “2.3.3 Grounding the Base Station”.
2. Use a shielded CAT5 cablefeed to connect the OBR base station to the surge suppressor.
3. Use two inline surge suppressors, one for all OBR3650HP cablefeed installations at the base of the tower and another for the first surge suppressor and the WES800. Connect the shield of the cablefeed to the ground lug of the surge suppressor. The purpose of the surge suppressor is to shunt to ground any over voltage [>60 V] transients that may be induced on the CAT5E cablefeed via lightning or other high voltages.

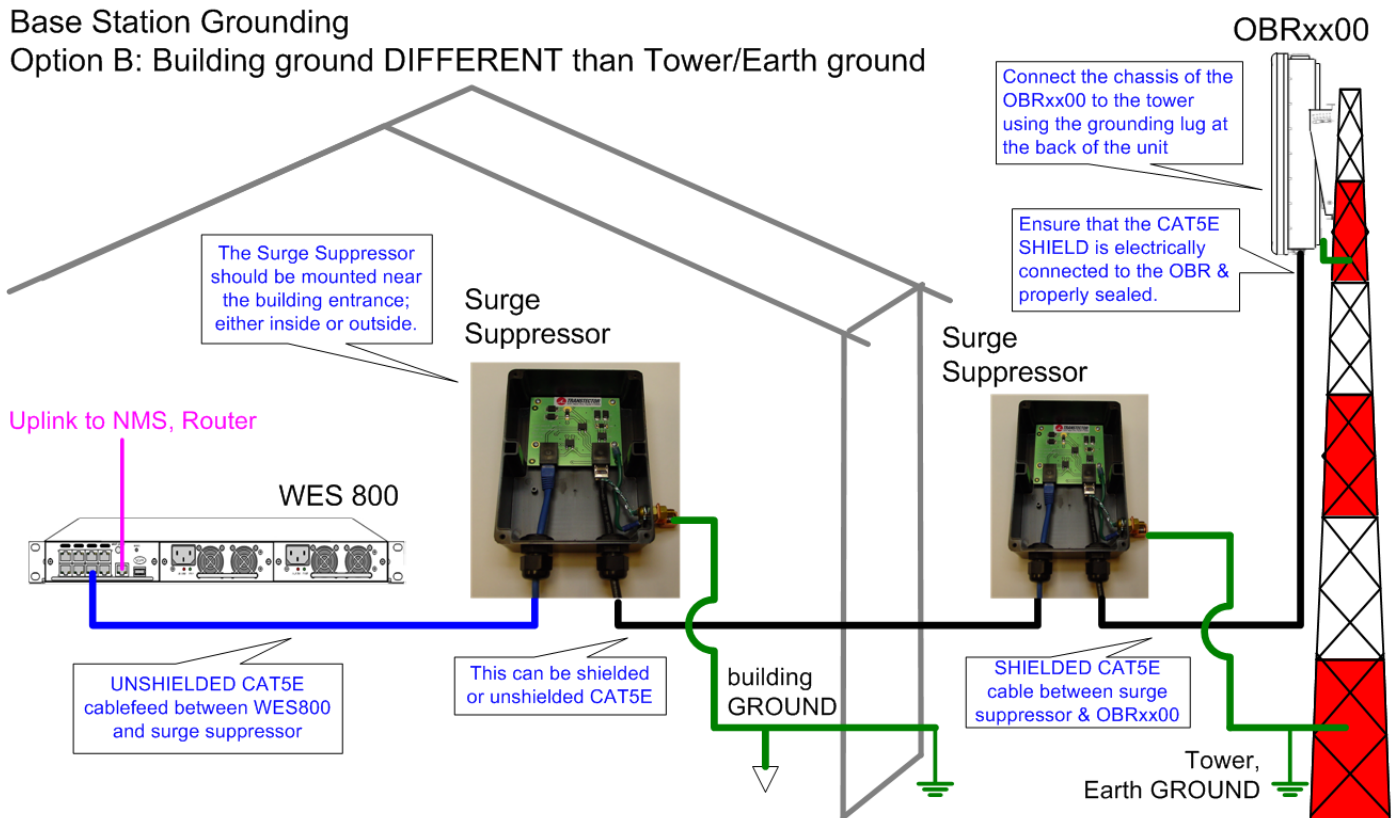

Figure 2-12 Base Station Grounding - building ground different than tower ground

This page intentionally left blank