

# USER MANUAL

HAX-300-500

## Parts and Function

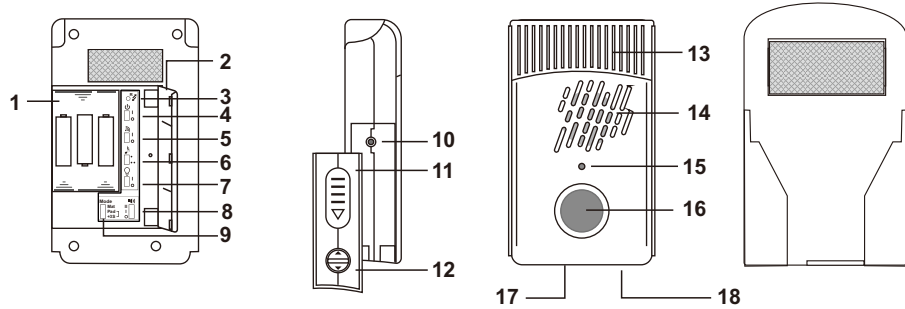

- |                                 |                         |                             |
|---------------------------------|-------------------------|-----------------------------|
| 1. Batteries compartment        | 7. Light on/off switch. | 13 Flasher                  |
| 2. Battery Door                 | 8. Volume control.      | 14. Speaker                 |
| 3. Regenerates new code button. | 9. Mode control.        | 15 LED indicator.           |
| 4. Power on/off switch          | 10. Sensor input jack   | 16. Test /Reset button      |
| 5. Transmitter On/off switch.   | 11. Anti-take off Cover | 17. External DC jack        |
| 6. Alert sound selector.        | 12 Cover lock           | 18. Nurse call button jack. |

## Power

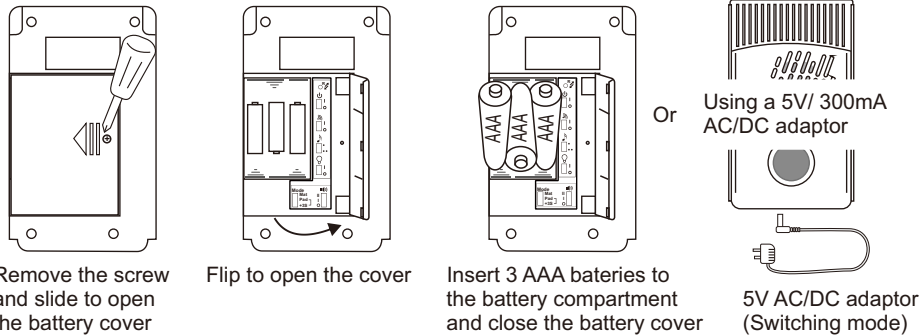

Remove the screw and slide to open the battery cover

Flip to open the cover

Insert 3 AAA batteries to the battery compartment and close the battery cover

5V AC/DC adaptor (Switching mode)

## Installation

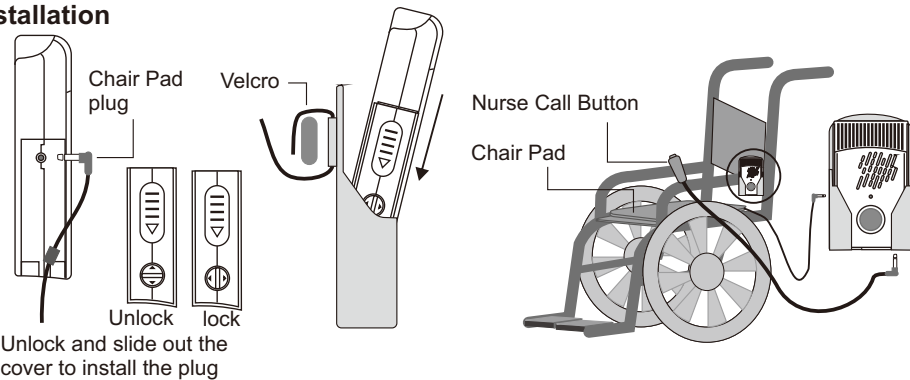

Unlock and slide out the cover to install the plug

### FCC Statement:

This equipment has been tested and found to comply with the limits for a Class B digital device, pursuant to part 15 of the FCC Rules. These limits are designed to provide reasonable protection against harmful interference in a residential installation. This equipment generates, uses and can radiate radio frequency energy and, if not installed and used in accordance with the instructions, may cause harmful interference to radio communications. However, there is no guarantee that interference will not occur in a particular installation. If this equipment does cause harmful interference to radio or television reception, which can be determined by turning the equipment off and on, the user is encouraged to try to correct the interference by one or more of the following measures:

Reorient or relocate the receiving antenna.

Increase the separation between the equipment and receiver.

Connect the equipment to an outlet on a circuit different from that to which the receiver is connected.

This device complies with part 15 of the FCC rules. Operation is subject to the following two conditions: (1) This device may not cause harmful interference, and (2) this device must accept any interference received, including interference that may cause undesired operation.

**Note: Modifications to this product will void the user's authority to operate this equipment.**

## Setting

Slide the switches inside the battery cover for your needs.

- Power** Switch to off position when do not use this device.
- Transmitter On/Off switch** On : Send a trigger signal to receiver when triggered  
Off : Do not send signal to receiver when triggered.
- Sound selector** Select the suitable sound by slide this switch to or position..
- Light On/Off** Turn the flash light on or off by slide this switch.
- Mode**  
Mat (Fall mat): This mode for fall mat or entry mat. The unit triggered when someone step on the mat.

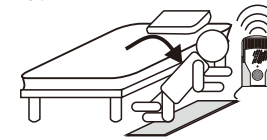
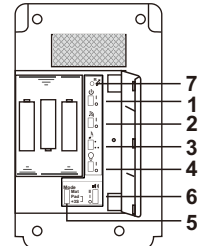

Pad (Bed Pad): This mode for seat pad or bed pad. The unit triggered when Patients or elderly leave the pad.

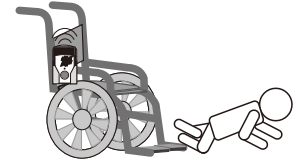

Pad +3S (Pad & 3 seconds delay): Same as Pad mode but delay 3 seconds for reduce False alarms.

- Volume control** You can select High / Low / No sound by slide this switch.
- Regenerate a new code** If the RF code is conflict, press the button on the pin hole to regenerate a new code

## Pairing with receiver

This unit can work stand alone or work with the wireless receiver. If work with the receiver, you need to pairing with the receiver follow to the manual of the receiver.

## Operation

### Mat mode

The sensor unit will be triggered when someone step on the mat.

### Pad mode

when the person lying (sitting) on the sensor pad. The sensor unit will generate a beep tone to confirm the pad is function. The unit will be triggered when Patients or elderly leave the pad sensor. Alarm will stop when the person return to the pad or press the stop button.

### Delay Mode

Functions are same as Pad mode, but delay 3 seconds after triggered for reduce False alarms.

### Nurse call

Press the nurse button once (the big nurse call button must be plug in), the sensor unit will be send a trigger signal to receiver, and sensor unit will generate beep tone to indicate this button is pressed.

### Test & Reset

- Test: Press the test/Reset button once, The unit will generate a beep tone, LED will blink and will send a RF to the receiver (It will depend on the function switch setting)
- Reset: When the alarm is triggered, press the test/Reset thrice within 2 seconds will stop