



AUTOLIV INC. THIS DOCUMENT AND THE DATA DISCLOSED HEREIN OR HEREWITH IS PROPRIETARY AND MAY NOT BE REPRODUCED, USED OR DISCLOSED IN WHOLE OR IN PART WITHOUT WRITTEN PERMISSION FROM AUTOLIV INC.

REVISION HISTORY

Rev	Description	Date	Apprv'd
000	Initial Release per ECO 066734		Ref. PLM
001	Added "and User Manual" to title and added para to section 7.1. SP		Ref. PLM



AEL, Inc.
1011B Pawtucket Blvd.
Lowell, MA 01853

ATTENTION
USER OF THIS DOCUMENT IS RESPONSIBLE FOR DETERMINING CURRENT REVISION LEVEL BEFORE USING DOCUMENT.

TITLE: Installation Specifications and User Manual,Radar Sensor

DOCUMENT NO: E567781

INSTALLATION SPECIFICATION

REV. 001, PAGE 1 OF 14

TABLE OF CONTENTS

1.0	PURPOSE/SCOPE	3
2.0	MATERIALS/EQUIPMENT	3
3.0	APPLICABLE DOCUMENTS	3
4.0	DEFINITIONS	3
5.0	SPECIFICATIONS	3
5.1.	Preface	3
5.2.	SLR Sensor	3
5.2.1.	Dimensions and Weight of the SLR Sensor	3
5.0	SPECIFICATIONS	4
5.2.2	Detection Range / Azimuth Angle Measurement Range	5
5.2.3	Detection Angle Elevation	6
5.3.1	Distance To The Bumper Material	7
5.3.2	Angle with respect to bumper material	7
5.3.3	Effect Of Type- And Thickness Of Fascia Material	8
5.3.4	Effect of the paint	8
5.3.5	Smoothness of Fascia in Front of Antenna	8
5.3.6	Environmental Conditions	9
5.3.7	Protection From Mud And Dirt Buildup	10
5.3.8	Sensor mounting thermal considerations	10
6.0	SLR SENSOR SYSTEM	11
6.1.	Coordinate System	11
6.2.	Numbering of the Sensors	12
6.3.	Installation Dimensions	13
6.3.1	Y-direction	13
6.3.2	X-direction	13
6.3.3	Azimuth angle	13
6.3.4	Elevation Angle	13
7.0	APPENDIX	14
7.1.	Range Performance vs Attenuation	14

LIST OF FIGURES

Figure 1	4
Figure 2	5
Figure 3	6
Figure 4	6
Figure 5	7
Figure 6	7
Figure 7	10
Figure 8	11
Figure 9	12
Figure 10	12
Figure 11	14

1.0 PURPOSE/SCOPE

This document describes the specifications for installation of type SLR Radar Sensors.

2.0 MATERIALS/EQUIPMENT

N/A

3.0 APPLICABLE DOCUMENTS

Outline 6181175

DIN 40050-9 IP6K9K

IEC 68-2-6 Fc	IEC 68-2-7	IEC68-2-10	IEC68-2-11 Ka
IEC 668-2-14Nb	IEC 68-2-27	IEC 68-2-29	IEC68-2-30
IEC68-2-32	IEC68-2-38	IEC68-2-50	IEC68-2-51
IEC68-2-52	IEC68-2-56	IEC68-2-64Fh	IEC529, 13.4
SAE J1211	SAE J1812	SAE J1879	

4.0 DEFINITIONS

N/A

5.0 SPECIFICATIONS

5.1. Preface

This chapter describes the specifications to install short range SLR radar into bumpers. These specifications shall be complied with to enable the specified characteristics of the sensors as well as the complete system. Due to the various installation situations and applications, a measurement check is required to verify the actual installation implementation.

5.2. SLR Sensor

This chapter describes the characteristics relevant to the installation of SLR sensors in the bumper. In addition general specifications are mentioned, which have to be followed for each position to enable sufficient sensor performance. Therefore the following guidelines are to be observed very carefully. See annex for performance measurements.

5.2.1. Dimensions and Weight of the SLR Sensor

Figure 1 shows the dimensions of the SLR sensor (C-sample status) and details the mounting of the sensor.

Please refer to "Outline 6181175" for detailed drawings.

Sensor weight: 190 grams max.

5.0 SPECIFICATIONS

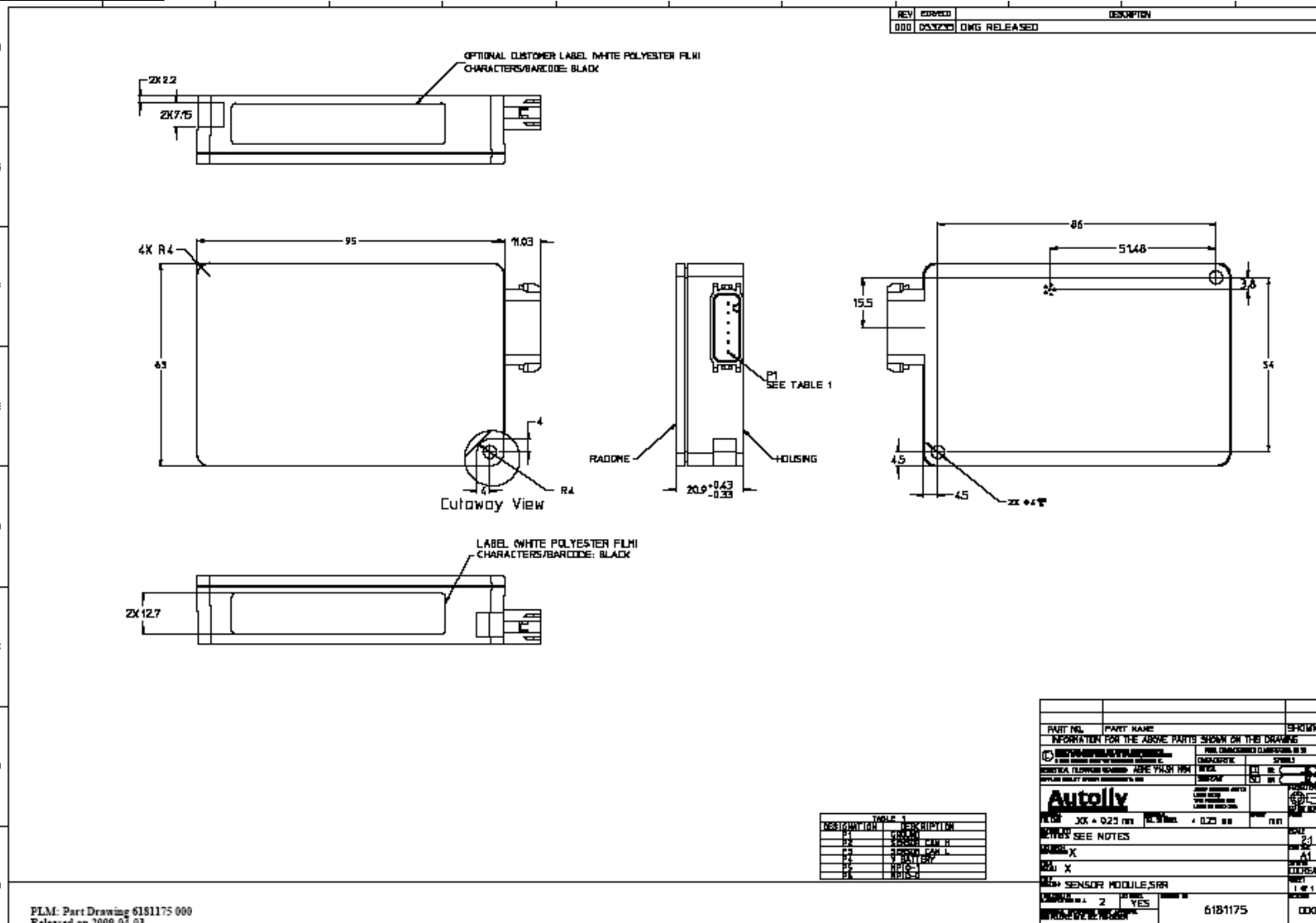

Figure 1

Important note: The two mounting holes are not specified for mounting the complete sensor. They do not provide the mechanical properties to keep the sensor in place. They shall be used to fix the sensor in a mounting bracket. Mounting tabs are to be fastened tight to mounting bracket using appropriate fastener. Maximum strength per tab is 270 N.

5.0 SPECIFICATIONS

5.2 SLR Sensor (cont'd)

5.2.2 Detection Range / Azimuth Angle Measurement Range

Figure 2 displays the detection area of the SLR sensor. One should differentiate between the detection area of the sensor and the angle measurement area. The angle measurement area is reduced to $\pm 40^\circ$ around bore sight whereas the detection area is $\pm 65^\circ$. The detection area is related to the 10dB points, this means the area where the signal amplitude is reduced by 10dB compared to bore sight direction.

Within the detection area of the antennas there must not be metal parts like screws, mounting brackets, license plate etc. The impact reducing foam material, clips or fascia laminations has to be avoided in that area.

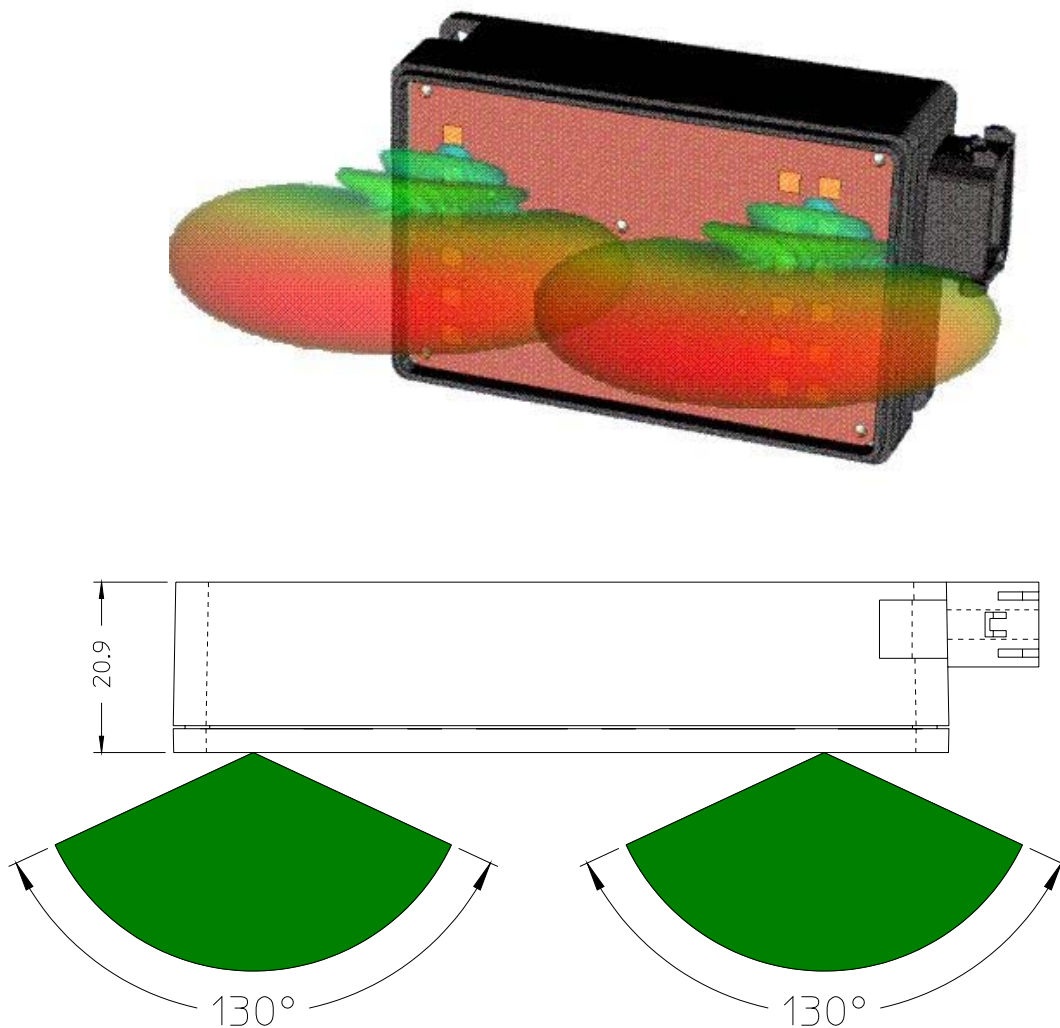

Figure 2

5.0 SPECIFICATIONS

5.2 SLR Sensor (cont'd)

5.2.3 Detection Angle Elevation

Figure 3 shows the detection area of the antennas in elevation. The detection area of $\pm 8^\circ$ is related to the 3dB points, this means the area where the signal amplitude is reduced by 3dB compared to bore sight direction. To avoid close range false objects there must not be metal parts like screws, mounting brackets, license plate etc in an angle of $\pm 30^\circ$ (see figure 3). Impact reducing foam material, clips or fascia laminations must be avoided in this area. Figure 4 shows details of objects keep out zone.

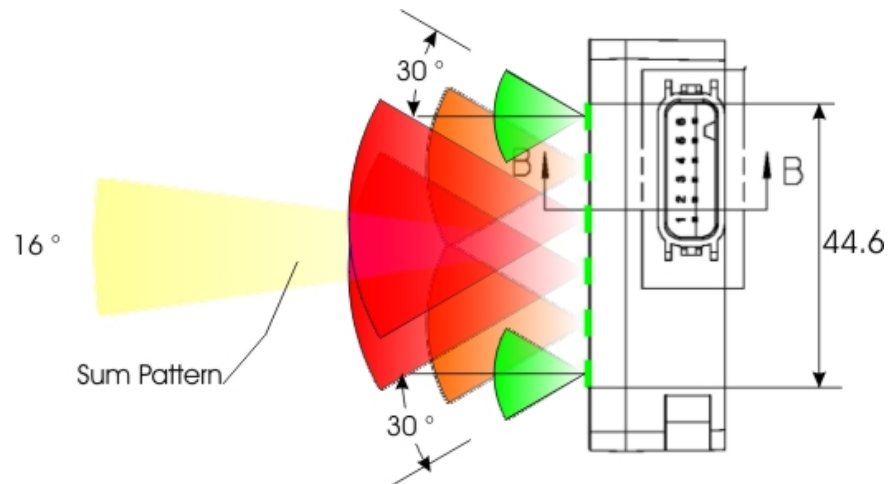

Figure 3

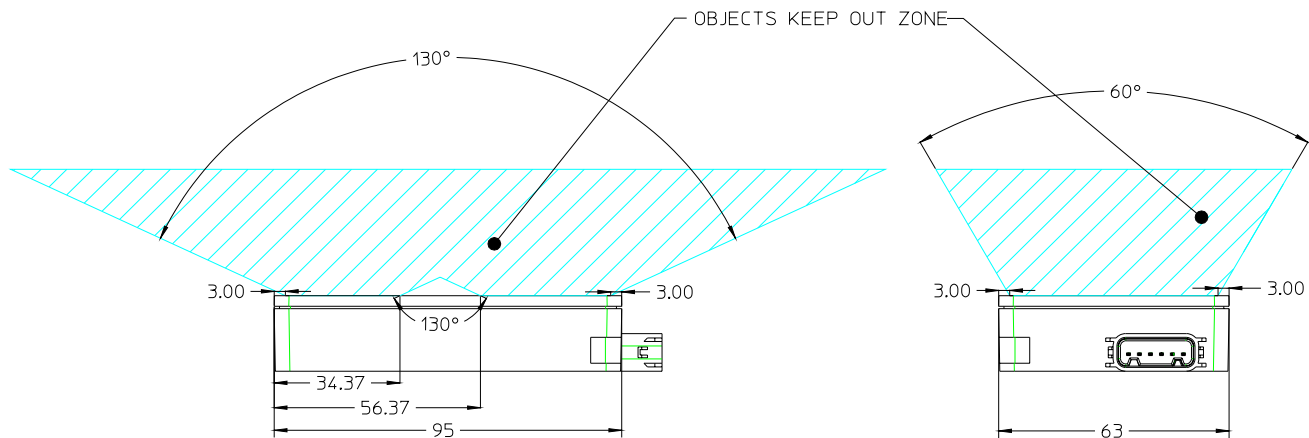

Figure 4

5.0 SPECIFICATIONS

5.3 Installation Specifications For Individual Sensors

5.3.1 Distance To The Bumper Material

The distance of the SLR sensor to the bumper shall be between 5 and 20 mm. If the distance is below 5 mm a significant signal loss occurs. If the distance is larger, error ranges may appear within the close range.

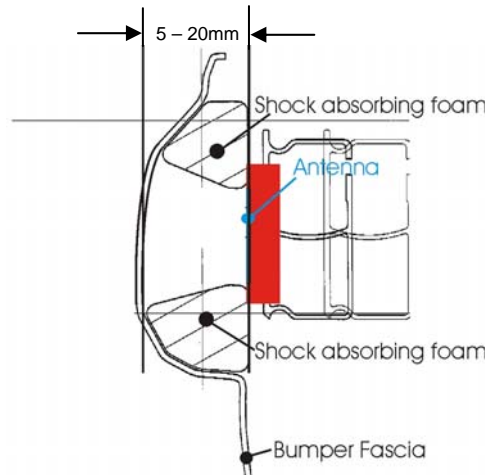

Figure 5

5.3.2 Angle with respect to bumper material

The angle φ of the sensor with regard to the bumper should be 0° , meaning the sensor should be installed parallel to the bumper. If this is not possible, an angle of $\pm 10^\circ$ shall not be exceeded. Other orientations need to be tested to confirm proper operation.

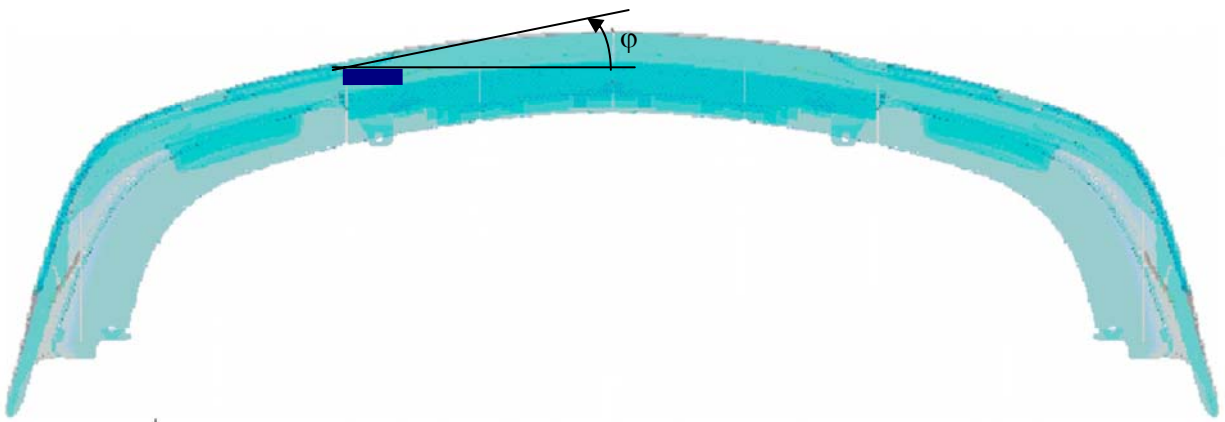

Figure 6

5.0 SPECIFICATIONS

5.3 Installation Specifications For Individual Sensors (cont'd)

5.3.3 Effect Of Type- And Thickness Of Fascia Material

Autoliv has examined various fascia material samples with a thickness of 2.5 – 4 mm. For those samples the radar signal is attenuated by 0.5 – 2 dB (corresponds to reduction of the range of coverage of 2 – 11%). The impact reducing material (foam) causes additional attenuation, especially when water is absorbed. Therefore there shall be no impact reducing material in the antenna areas as described in 5.2.2 – 5.2.3. There shall also be no metallic parts, snap-on contacts, clips or double wall laminations in the antenna areas as described in 5.2.2 – 5.2.3.

Fascia loss effects can be optimized by proper control of the material thickness and dielectric constant. For example, a fascia material measured to have a 2.2 dielectric constant would have less than 1 dB of loss at a thickness of 4.5 mm. Autoliv can analyze sample materials to determine the dielectric constant and proper thickness for optimal performance. Thickness and dielectric constant must be controlled to a tolerance of $\pm 10\%$ max to ensure optimal performance.

5.3.4 Effect of the paint

Depending upon the type of paint, number of coatings, base coats used, etc. the attenuation of the radar signal was measured between 2 and 5 dB (corresponds to reduction of coverage between 11 and 25%). Because attenuation has significant impact on performance, prior inspection of the material and paint samples are suggested. Autoliv can characterize painted fascia samples to determine the radar signal loss effects. Autoliv sensor specifications assume a maximum signal loss (2-way) of 4 dB due to fascia effects. Materials and paints that exhibit greater than 4 dB loss will degrade the specified performance. As noted in 5.3.3 performance can be optimized by proper control of the fascia material thickness and dielectric constant.

5.3.5 Smoothness of Fascia in Front of Antenna

Avoid sharp vertical or near vertical character lines in front of sensor antenna. Horizontal character lines seem to have little effect on sensor performance.

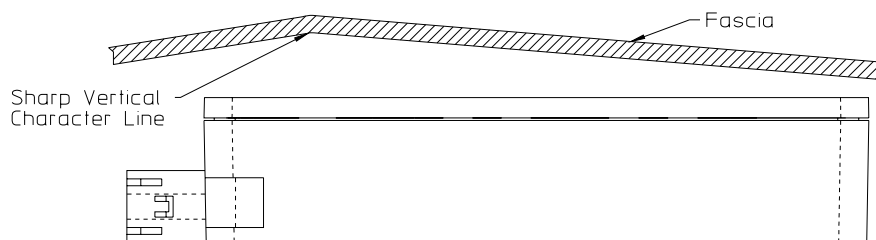

Top View

5.0 SPECIFICATIONS

5.3 Installation Specifications For Individual Sensors (cont'd)

5.3.6 Environmental Conditions

The following lists the environmental conditions the sensor is designed to operate in. The location and mounting of the sensor must not create conditions that exceed the following:

1. Temperature extremes and applicable tests according to SAE J1211 Table 1, Zone 2.1
2. Operational Integrity according to SAE J1812, Range 1
3. Functional Classification according to SAE J1812, Class B
4. Generic Environmental Requirements SAE J1879

Examples:

Operating Temperature: -40° to +85°C
Assumes non-moving air, sensor backside surface exposed to free air.

Max. Storage Temp: +105 °C

5. Temperature tests SAE J1211 4.1, 5.9 IEC68-2-1 Aa, Ab, Ad, IEC68-2-2, Ba, Bb, Bd, IEC68-2-33, IEC68-2-14, SAE J1879 4.1, IEC68-2-18 Rb3, IEC68-2-14 Nc, IEC68-2-5
6. Humidity test Per IEC68-2-56 Cb, Db IEC68-2-30, IEC 68-2-10, IEC68-2-38, SAE J1211 4.2, 5.9,
7. Mechanical Shock Per IEC 68-2-27 Ea & Eb & IEC 68-2-29
8. Vibration over Temp. Per IEC 68-2-64Fh & IEC 668-2-14Nb, IEC68-2-50, IEC68-2-51
9. Free Fall Per IEC 68-2-32 Ed, Version 1
10. Constant Acceleration Per IEC 68-2-7
11. Resonance frequency Per IEC 68-2-6 Fc, SAE J1211 4.7, 5.9
12. Salt Spray Per IEC68-2-11 Ka , IEC68-2-52
13. Water Immersion/Protection Per DIN 40050-9 IP6K9K
14. Dust Protection Per DIN 40050-9 IP6K9K & IEC529, 13.4
15. Fluid Compatibility according to installation area

5.0 SPECIFICATIONS

5.3 Installation Specifications For Individual Sensors (cont'd)

5.3.7 Protection From Mud And Dirt Buildup

There will be performance degradation if excessive buildup occurs on the antenna areas and especially for wet mud. Therefore Autoliv strongly recommends the sensor mounting include provisions to protect the antenna face from dirt and mud accumulation. The mounting concept should prevent mud and dirt from entering the free space between the sensor radome and the fascia. In addition the protection features must not interfere with the antenna areas as described in 5.2.2 – 5.2.3.

In order to minimize any possible influence the protection feature might have on the RF performance of the sensor it is recommended that the material thickness and dielectric constant be controlled to minimize the reflectivity of the material. Autoliv can characterize material samples and provide a recommended thickness. The thickness and dielectric constant must be controlled to a $\pm 10\%$ tolerance.

5.3.8 Sensor mounting thermal considerations

The sensor is specified to operate in a -40° to $+85^{\circ}\text{C}$ ambient, still air environment. Natural convection and venting from the front and backside surfaces of the sensor to the ambient air is assumed. Therefore the mounting concept shall leave both the front radome and backside area of the sensor exposed to the ambient air. Minimum area to be left for the backside exposed is as shown below. Maximum surface temperature in this region is $+115^{\circ}\text{C}$ at a maximum ambient of $+85^{\circ}\text{C}$.

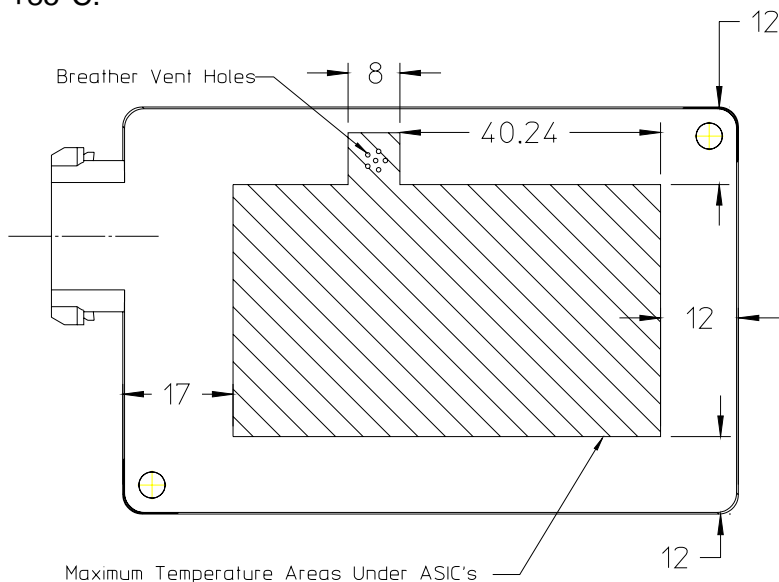

Figure 7

6.0 SLR SENSOR SYSTEM

The following observations refer to the combination of several SLR sensors into one sensor system. Many applications require several sensors networked together to achieve the desired function. The sensors should be placed in the best possible location for optimal coverage and range performance relative to the specific applications. The optimal locations will be highly dependent on the desired applications and the bumper dimensions. Autoliv can perform analysis and characterization to determine sensor locations to best achieve a desired performance. Attention should be paid that the installation specifications for individual sensors from chapter 5 are maintained. Due to the various installation situations and applications, a measurement check is required to verify the actual installation implementation.

6.1. Coordinate System

Figure 8 shows the coordinate system used for identifying sensor position in a multi-sensor application. The arrows indicate positive values. The most forward location on the bumper was selected as reference point. The Z-axis is the vertical axis. Z-values are indicated from the ground surface.

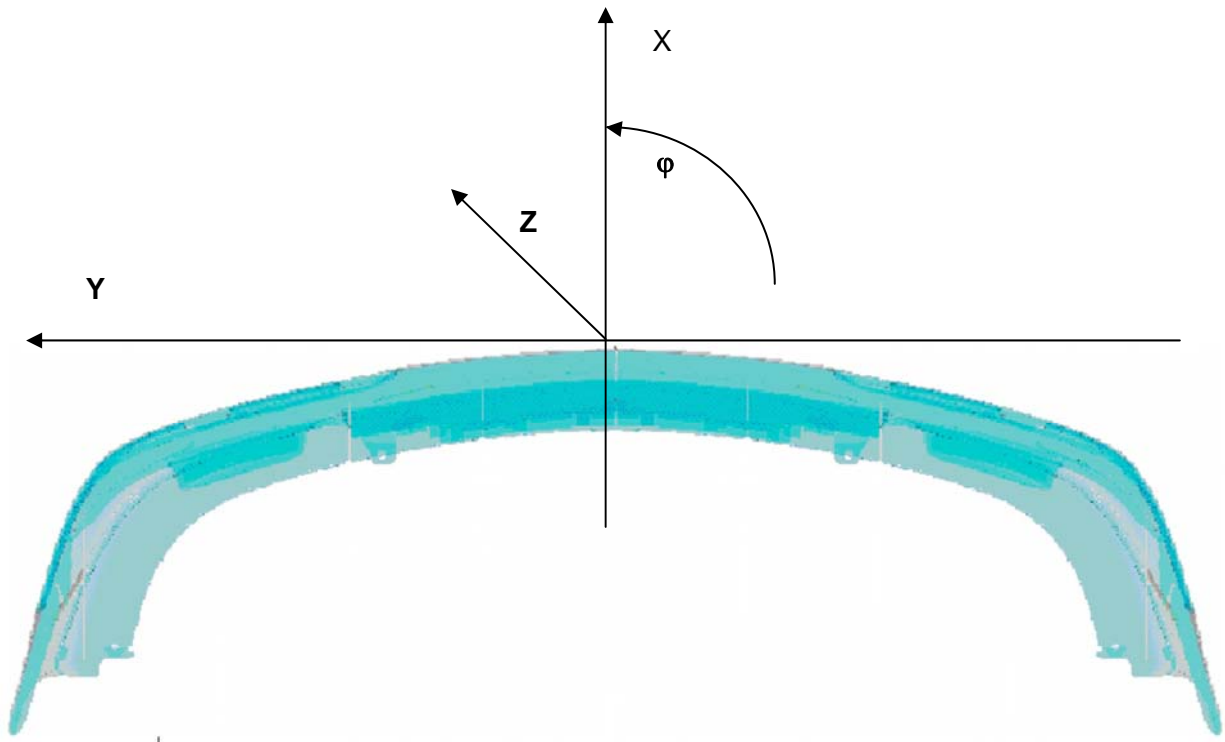

Figure 8

6.0 SLR SENSOR SYSTEM

6.2. Numbering of the Sensors

The following provides a guideline for sensor numbering (addressing) in a multi-sensor system. The example used is for a front and rear bumper system. Each bumper contains up to 4 sensors connected on a private CAN bus. A separate CAN bus is used for the front and rear bumpers. The sensors transmit data over the CAN bus to a centralized processor which performs sensor data fusion and runs the desired application.

Figure 9 shows the numbering used for a front sensor system.

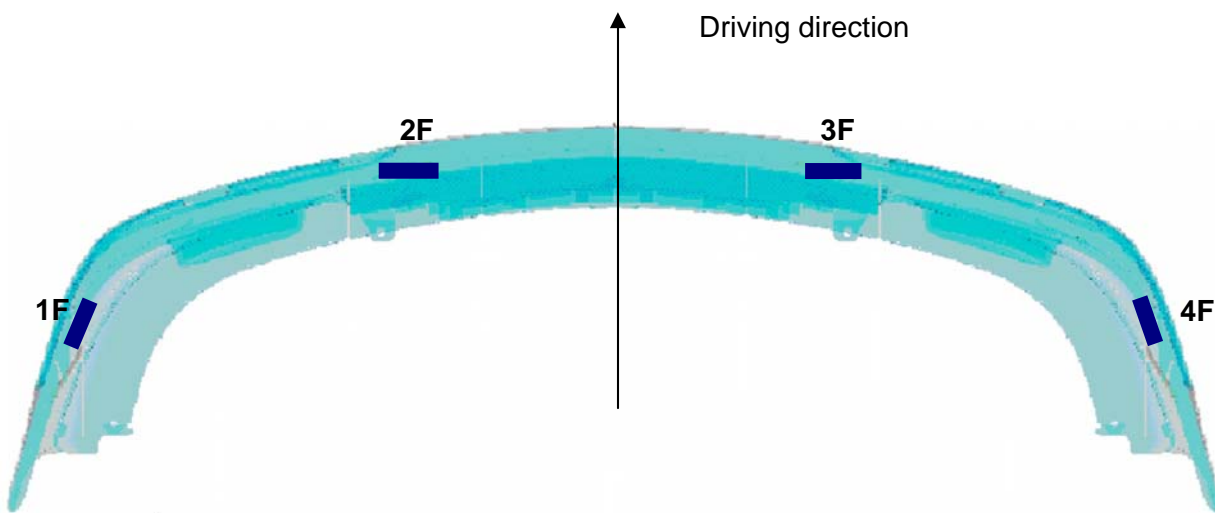

Figure 9

Figure 10 shows the numbering used for a rear sensor system.

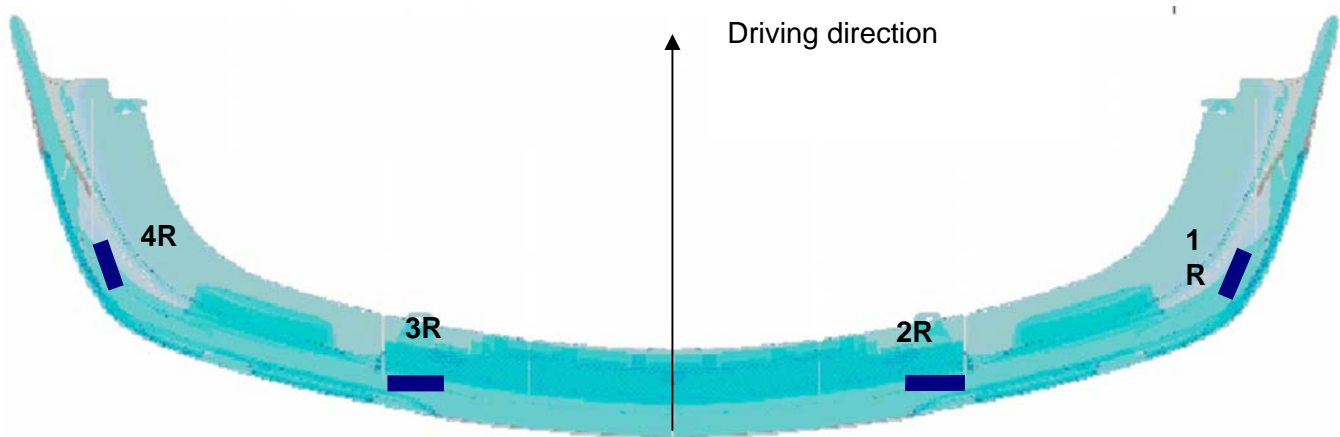

Figure 10

6.0 SLR SENSOR SYSTEM

6.3. Installation Dimensions

6.3.1 Y-direction

The Y location of the sensors will determine the extent of the coverage zone and the size of any detection gaps. The location selections are highly dependent on the desired application and bumper dimensions. In general, for a 2 sensor longitudinal system sensors 2 & 3 should be located midway between the center of the bumper and the outer corner. Bumper features (license plates etc.) may not allow this while maintaining the guidelines of section 5. In this case the locations should be as close to the ideal locations as possible while meeting the requirements of section 5. A measurement check is required to verify the actual installation implementation.

6.3.2 X-direction

The X location of the sensors not as critical as Y in terms of system performance. In general the X locations will be dictated by the contour of the bumper and the installation guidelines of section 5.

6.3.3 Azimuth angle

For best longitudinal coverage from sensors 2 & 3 the Azimuth angle of the sensors has to be in the range of 0°. For systems, which are used exclusively for parking distance control, larger angles up to 10° might be sensible if required to improve range of coverage.

6.3.4 Elevation Angle

For best range performance the elevation angle of the sensors shall be 0 deg min, +1° max with respect to the ground (sensor radome surface perpendicular (90°) to the ground). The main beam of the sensor (90° to the installation position) may under no circumstances cross the plane of the roadway before the desired coverage range.

For applications that only require short ranges (up to 5m) detection of low objects (curbstones, low walls, etc.) may be desired. An incline toward the ground of up to 10° can be used.

7.0 APPENDIX

7.1. Range Performance vs Attenuation

The chart below illustrates the effect of attenuation of the radar signals on the radar sensor detection range. Factors that can cause attenuation of the radar signals include fascia material, paint, dirt and mud buildup, foam material, or other mechanical obstructions in the sensor field of view. For example, if a material is placed in front of the sensor which attenuates the signal 12 dB (2 way loss) the maximum detection range of the sensor will decrease by 50%.

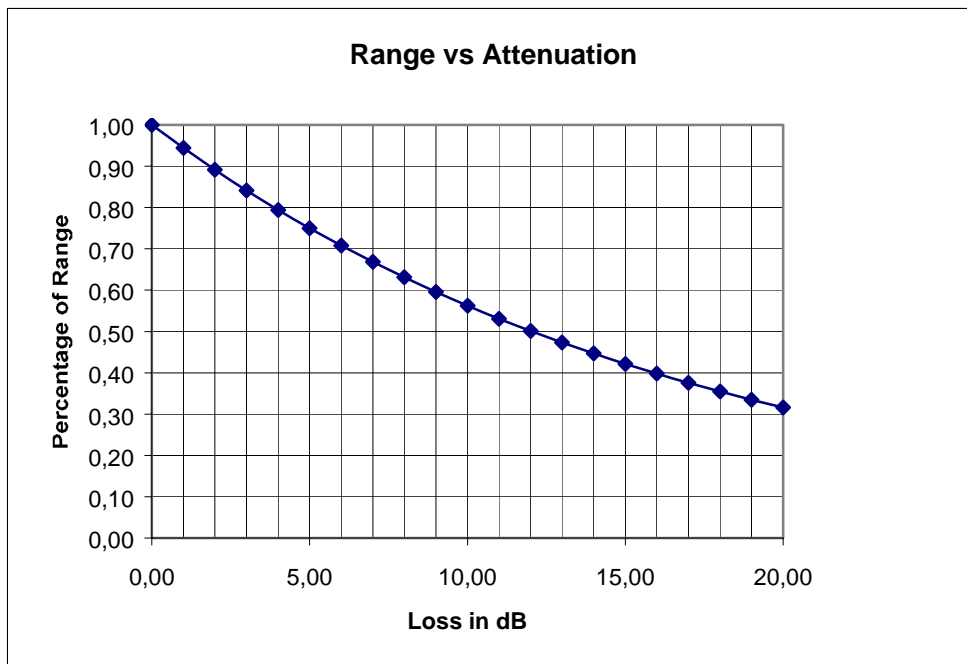

Figure 11

This device complies with Industry Canada RSS210 rules.

Operation is subject to the following two conditions:

1. This device may not cause interference and
2. This device must accept any interference, including interference that may cause undesired operation of the device.