

Table of Contents

Page	Page
3 > Welcome	14 > Contacts
3 > Vertu Packaging Contents	15 > Text Messages
3 > Conventions	16 > Vertu Concierge
4 > Important Information	17 > Accessories
4 > Safety Points	21 > CD-ROM
5 > Vertu Phone Layout	22 > Care and Maintenance
6 > The Battery and SIM Card	24 > Battery Information
7 > Vertu Phone Keypad	24 > Safety Information
8 > Switching on your Vertu phone	26 > Specifications
8 > Setting the Time and Date	27 > Warranty
9 > Display Icons and Indicators	30 > Vertu Regional Offices
9 > Making Calls	31 > SAR Notice – RHV-2
10 > Emergency Calls	33 > Notice
11 > Keypad lock	33 > EU Recycling Notice
12 > Menu Navigation	

WELCOME

Vertu was born from an obsession to create a personal communication instrument that deployed craftsmanship and technology in a way that had never been achieved before.

This involved taking the finest materials from the world of watch making, automotive, aeronautics and jewellery and then making them even better, to come up to the exacting standards demanded by Vertu.

The Vertu Signature is inspired by the tradition of Grand Complication timepieces. Every part of every Signature is made to Vertu's own design, including 388 mechanical components, 18 ruby bearings and 69.25 carats of sapphire crystal. A total of 74 patents protect its intellectual property. The Vertu Signature is unarguably the finest handset ever made.

REGISTER YOUR VERTU PHONE

Vertu aims to provide you with the very best service possible.

To enable us to do this, please register your Vertu phone by visiting www.verturegistration.com or by calling Vertu Concierge using the dedicated key on the side of your handset.

VERTU PACKAGING CONTENTS

- 1 Vertu phone
- 1 Certificate of ownership
- 1 Vertu Concierge Benefits booklet
- 1 Registration card
- 1 Microfibre polishing cloth
- 1 User guide
- 1 CD-ROM
- 1 Battery
- 1 Charger
- 1 Connection adaptor lead
- 1 Vehicle charger
- 1 Data cable
- 1 Headset
- 1 Back cover release key

The packaging contents may vary slightly in accordance with regional regulations.

CONVENTIONS

Menu Represents text that appears on your Vertu phone's display, for example, "From the stand-by display, press **Menu**."

SEND Represents a Vertu phone key, for example, "Press the **SEND** key to make the call."



Important information relating to safety.



Represents useful information or a quick way to access or operate a feature.



Represents points to be aware of when using your Vertu phone.

GLOSSARY

NUMBER KEYS The keys that are used to enter (key in) text or numbers.

DEFAULT Initial product setting as supplied by Vertu when it leaves our manufacturing facility.

SIM CARD Subscriber Identity Module. This is a small card supplied by your service provider to insert into your Vertu phone for a network connection.

SERVICE PROVIDER The provider of your SIM card and all associated network services.

NETWORK SERVICE A feature which is made available at the discretion of your service provider.

STAND-BY DISPLAY The display that appears when your Vertu phone is switched on, with **Menu** and **Go to** at the bottom.

REFERENCE MANUAL

Throughout this guide we mention the Reference Manual which contains additional information about your Vertu phone's functionality. There is an electronic copy on the CD-ROM supplied with your Vertu phone but if you do not have access to a compatible computer, contact Vertu Concierge for a printed copy.

The Reference Manual may not be available in your language.

IMPORTANT INFORMATION

The wireless phone described in this guide is approved for use on GSM 900/1800/1900 networks. Contact your service provider for more information about networks.

When using your Vertu phone, obey all laws and respect the privacy and legitimate rights of others.



To use any features in your Vertu phone, other than the alarm clock, the phone must be switched on. Do not switch your Vertu phone on when wireless phone use is prohibited or when it may cause interference or danger.

NETWORK SERVICES

To use the phone you must have service from a wireless service provider. Many of the features in your Vertu phone depend on features in the wireless network to function. These network services may not be available on all networks or you may have to make specific arrangements with your service provider before you can utilise certain network services. Your service provider may need to give you additional instructions for their use and explain what charges will apply. Some networks may have limitations that affect how you can use network services. For instance, some networks may not support all language-dependent characters and services.

Your service provider may also have requested that certain features be disabled or not activated in your Vertu phone. If so, they will not appear on your menus. Contact your service provider for more information.

SHARED MEMORY

Some of the data features in your Vertu phone share memory. Using one or more of these features may reduce the memory available for the remaining features sharing memory. For example, saving many multimedia messages and voice recordings may use all of the available memory. Your phone may display a message that the memory is full when you try to use a shared memory feature. In this case, delete some of the information or entries stored in the shared memory features before continuing. Some of the features, such as the contacts list, have a certain amount of memory specially allotted to them in addition to the amount of memory shared with other features.

SAFETY POINTS



Read the following simple guidelines. Not following them may be dangerous or illegal. Read the complete user guide for further information.

For full safety instructions see "Safety Information" on page 24.



ROAD SAFETY COMES FIRST

Obey all local laws. Always keep your hands free to operate the vehicle while driving. Your first consideration while driving should be road safety.



INTERFERENCE

All wireless phones may be susceptible to interference which could affect performance.



SWITCH OFF IN HOSPITALS

Follow any restrictions. Switch phone off near medical equipment.



SWITCH OFF IN AIRCRAFT

Follow any restrictions. Wireless devices can cause interference in aircraft.



SWITCH OFF WHEN REFUELLING

Do not use the phone at a refuelling point. Do not use near fuel or chemicals.



SWITCH OFF NEAR BLASTING

Follow any restrictions. Do not use the phone where blasting is in progress.



USE SENSIBLY

Use only in normal position (shown on page 10). Do not touch the antenna unnecessarily.



QUALIFIED SERVICE

Only qualified personnel may install or repair this phone.



ACCESSORIES AND BATTERIES

Use only approved accessories and batteries. Do not connect incompatible products.



WATER RESISTANCE

Your Vertu phone is not water resistant. Keep it dry.



BACK-UP COPIES

Remember to make back-up copies or keep a written record of any important information stored in your phone.



CONNECTING TO OTHER DEVICES

When connecting to any other device, read its user guide for detailed safety instructions. Do not connect incompatible devices.



EMERGENCY CALLS

Ensure your Vertu phone is switched on and in service. Press the END key as many times as needed to return to the stand-by display. Enter the emergency number, then press the SEND key. Give your location. Do not end the call until told to do so.

VERTU PHONE LAYOUT

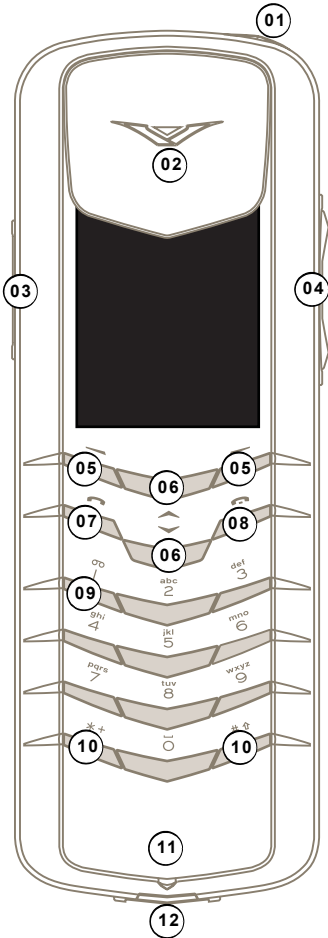

- > 01 POWER key – press and hold for a few seconds to switch on and switch off.
- > 02 Earpiece.
- > 03 CONCIERGE key – press and hold until **Concierge** is displayed. Press SEND to call.
- > 04 VOLUME key – press the top of the key to increase the volume. Press the bottom of the key to decrease the volume.
- > 05 SELECTION keys – press to perform the action or access the feature shown on the display above the key.
- > 06 SCROLL keys – press to move, for example through a list of names or features.
- > 07 SEND key – press to make or answer a call.
- > 08 END key – press to end a call.
- > 09 VOICEMAIL key – press and hold to call your voice mailbox (a network service).
- > 10 *+ and #† keys – special function keys.
- > 11 Microphone.
- > 12 Accessories connector.

THE BATTERY AND SIM CARD

If your Vertu phone was purchased at a Vertu store, the battery and SIM card should have been installed already. Otherwise, follow the procedure below to install your battery and SIM card.

The SIM card and its contacts are easily damaged. Be careful when handling, inserting or removing the card.



Keep SIM cards and the back cover release key out of the reach of small children.

Always switch the phone off and disconnect the charger before removing the battery.

Do not remove the release tab or the protective plastic film from the battery as this will damage the battery.

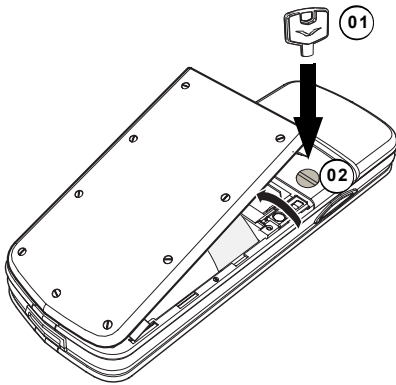

- > With the back of your Vertu phone facing you, position the back cover release key (01) very carefully into the slot of the locking screw (02). Ensure the key does not slip out of the slot
- > Turn the locking screw (02) a quarter of a turn anticlockwise, and gently lift off the back cover as shown. If you accidentally remove the back cover while the phone is switched on, the phone will automatically switch off.



Attach the back cover release key to your keyring for convenience.

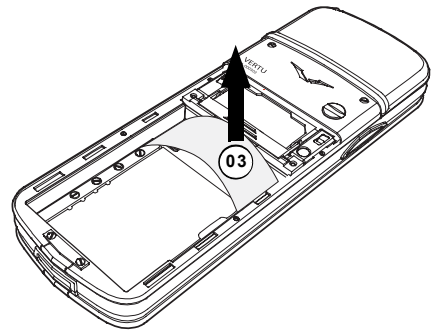

- > Remove the plastic placeholder (03) from your Vertu phone before inserting the battery.



Retain the plastic placeholder for future use. If you need to remove the battery, insert the plastic placeholder before replacing the back cover to make it easier to remove the back cover.

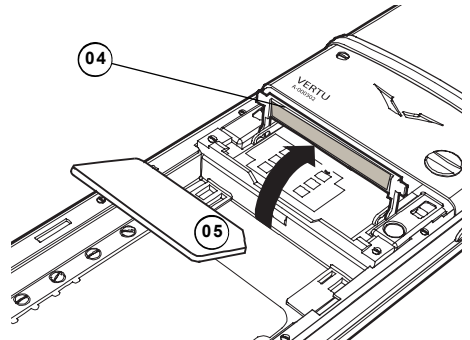

- > Slide the retaining bar (04) towards the top of your Vertu phone and then pivot upwards.
- > Insert the SIM card, ensuring that the bevelled corner (05) is located top right and the gold contact area is facing downwards.
- > Return the retaining bar to its original position and slide it towards the bottom of the phone. The retaining bar should firmly lock into place.



For availability and information on using SIM card services, contact your SIM card vendor. This may be the service provider, network operator, or other vendor.

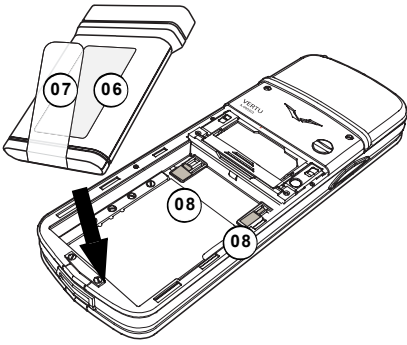

- > Insert the battery (06) bottom end first with the release tab (07) facing up from the rear of the phone. Ensure that the contacts on the top end of the battery align with the contact points (08) inside the battery compartment.
- > Ensure that the battery and SIM card are seated correctly before replacing the back cover.

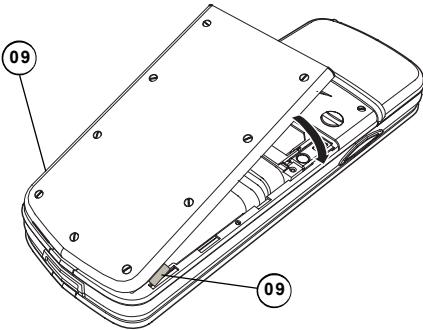

- > To replace the back cover, locate lugs (09) as shown.
- > Pivot the back cover into position until it clicks into place. The cover should close tightly using only light pressure – do not force it closed! If the cover does not close easily, remove it and check the battery and SIM are correctly inserted, and the retaining bar (10) is correctly positioned and locked.

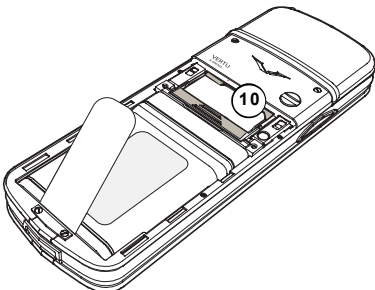

For information about removing the battery, see "Removing the battery" on page 19

VERTU PHONE KEYPAD

Alphanumeric keys, referred to as **NUMBER** keys in this guide, are used to key in numbers or characters, for example when making calls, storing names in the directory or writing text messages.

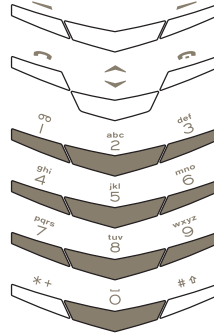

Below the display are two **SELECTION** keys. The function of these keys depends on the text displayed above them.

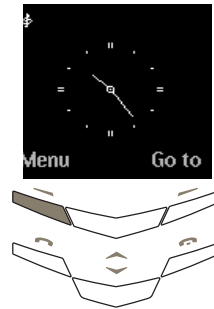

For example, press the **SELECTION** key below **Menu** to access the menu or press the **SELECTION** key below **Go to** to access the shortcuts menu.

When pressing keys, press them briefly and firmly, without holding them down unless otherwise instructed.

SWITCHING ON YOUR VERTU PHONE

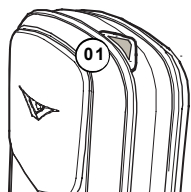

- > Press and hold the **POWER** key (01) for a few seconds to switch on your Vertu phone.

If your battery requires charging, a **Battery low** message is displayed when you first switch on your Vertu phone. See “Charging your Battery” on page 18 for more information.

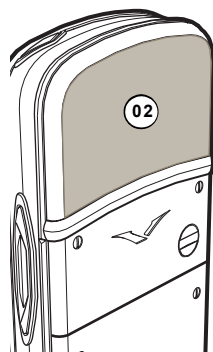

- > Your Vertu phone has an internal antenna located inside the top-rear panel (02). Do not touch the antenna unnecessarily when the phone is switched on.

Contact with the antenna affects call quality and may cause the phone to operate at a higher power level than otherwise needed. Avoiding contact with the antenna area when operating the phone optimises the antenna performance and battery life.

ENTERING YOUR PIN CODE

Depending on your SIM card settings, you may be prompted to enter a PIN (Personal Identification Number) code when you switch on your Vertu phone. This code is used to protect access to your SIM card and is independent of your Vertu phone. If you used your SIM card in another phone previously, the code will be the same.

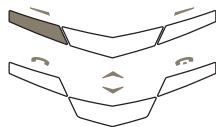

- > Use the **NUMBER** keys to key in your PIN code.
- > Press **OK**.



It is recommended that you activate both the PIN code and security code to help prevent unauthorised use of your SIM card and your Vertu phone. See the “Security” chapter of the Reference Manual for more information.

SETTING THE TIME AND DATE

If the time and date are not set, you will be prompted to enter your time settings when you first switch on your Vertu phone.

If your Vertu phone was purchased at a Vertu store, the time and date should already be set for you.



We recommend setting the time and date immediately to ensure that features which use the time and date (for example, the Organiser) operate correctly.

To set the time when you switch on your Vertu phone for the first time:



- > Use the **NUMBER** keys to key in the correct time.
- > Use the **SCROLL** keys to toggle between hours and minutes.

You can enter the time in either 12-hour (am/pm) format or 24-hour format.

For example, to set the time to 08:30:

- > Key in “8”.
- > Scroll to minutes. The leading zero is added to the hour figure.
- > Key in “30”.
- > Press **OK**.

Or, to set the time to 12:30:

- > Key in “12”. The cursor automatically jumps to the minutes.
- > Key in “30”.
- > Press **OK**.

If the hour you entered was not in 24-hour format, you are prompted to confirm if the time entered is am or pm:

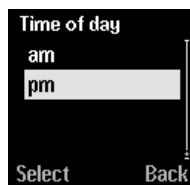

- > Scroll to **am** or **pm**.
- > Press **Select**. The time zone screen is displayed.

To select your local time zone:

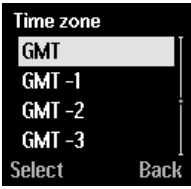

- > Scroll to the appropriate time zone.
- > Press **Select**. The date screen is displayed.

To set the date:



- > Use the **NUMBER** keys to key in the date.
- > Use the **SCROLL** keys to move between the figures.
- > Press **OK**. A confirmation message is displayed.

 *If the battery is removed from your Vertu phone for longer than two hours, you may need to set the time and date again.*

You can enable your Vertu phone to automatically adjust your date and time settings. See the Reference Manual for more information about changing the time and date settings.

DISPLAY ICONS AND INDICATORS

The display shows the current status of your Vertu phone.

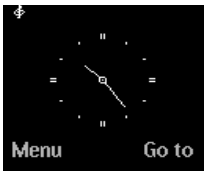

The battery charge and signal strength indicators appear at the top of the display.



Indicates the signal strength of the network at your current location.



Indicates the battery charge level.



Indicates that both battery and signal levels are at full strength.



Indicates that both battery and signal levels are below full strength.



Indicates that the signal strength at your current location is too weak to make calls.

Status icons are displayed below the battery charge and signal strength indicators. The most commonly displayed icons are:



Indicates that you have received one or more text messages.



Indicates that you have received one or more voice messages (a Network Service).



Indicates that the **General** profile is selected. Alternative icons are displayed for other profiles.



Indicates that audible alerts are disabled and no sounds are made when you receive calls or messages.



Indicates that the keypad is locked.

See the Reference Manual for a complete list of icons and their meaning.

MAKING CALLS

YOUR FIRST CALL



> Check the signal strength indicator. If the display indicates a poor signal, adjust your physical location to be clear of obstructions that may block the signal.



> From the stand-by display, use the **NUMBER** keys to key in the number you want to call.

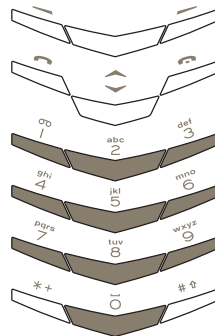

*When keying in international numbers, press the **#1** key twice instead of keying in the international access code. A plus (+) sign appears on the display to represent the international access code.*

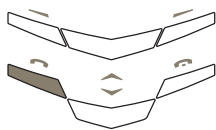

> Press the **SEND** key to begin your call. It may take several seconds to establish your call.



> Hold your Vertu phone in the normal speaking position during your conversation. Avoid unnecessary contact with the antenna as this may degrade call quality.

ANSWERING CALLS

When you receive an incoming call, by default, a ringing tune is played and a call message is displayed. If enabled, your Vertu phone also vibrates.

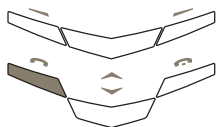

> Press the **SEND** key to answer an incoming call.



While in a call, you can use the speaker phone for a hands free call. See the Reference Manual for more information.

ADJUSTING VOLUME

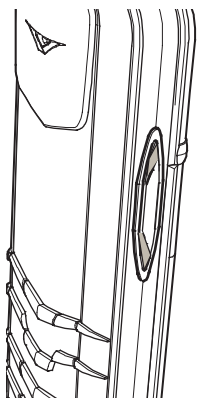

Use the **VOLUME** key on the right side of your Vertu phone to obtain a comfortable listening level. The key has a rocker action.

- > Press the top of the key to increase the volume.
- > Press the bottom of the key to decrease the volume.

ENDING OR REJECTING CALLS

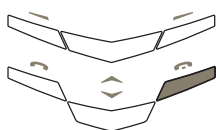

> Press the **END** key to end a call or reject an incoming call.

LAST NUMBER REDIAL

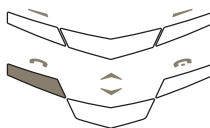

> From the stand-by display, press the **SEND** key to access a list of the most recently dialed numbers.

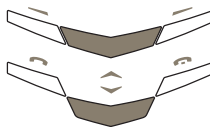

> Use the **SCROLL** keys to scroll to the desired number.

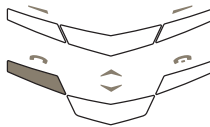

> Press the **SEND** key to call the selected number.

CALLING YOUR VOICE MAILBOX

Voice mail is a network service for receiving voice messages that may be offered by your service provider.

To use the **VOICEMAIL** key to listen to your voice messages, the voice mailbox number must be stored in your Vertu phone.

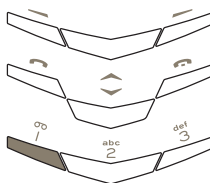

- > Press and hold the **1** key. This is the **VOICEMAIL** key.
- > If you are prompted, key in the voice mailbox number and press **OK**.

For more information on voicemail contact your service provider.

EMERGENCY CALLS



Your Vertu phone, like any wireless phone, operates using radio signals, wireless and landline networks as well as user-programmed functions. Because of this, connections in all conditions cannot be guaranteed. Therefore, you should never rely solely upon any wireless phone for essential communications, for example medical emergencies.

Emergency calls may not be possible on all wireless phone networks or when certain network services and/or phone features are in use. Check with local service providers.

MAKING AN EMERGENCY CALL

- > If the phone is not on, switch it on. Some networks may require that a valid SIM card is properly inserted in the phone.
- > Press the **END** key as many times as needed to return to the stand-by display.
- > Key in the emergency number for your present location, for example 112, 911 or other official emergency number. Emergency numbers vary by location.
- > Press the **SEND** key.

If certain features are in use, you may first need to turn those features off before you can make an emergency call. For more information consult the Reference Manual or your local service provider.

When making an emergency call, remember to give all the necessary information as accurately as possible.

Remember that your phone may be the only means of communication at the scene of an accident – do not cut off the call until given permission to do so.

KEYPAD LOCK

You can lock the keypad on your Vertu phone to prevent the keys being operated accidentally, for example when it is in your pocket or bag.

LOCKING THE KEYPAD

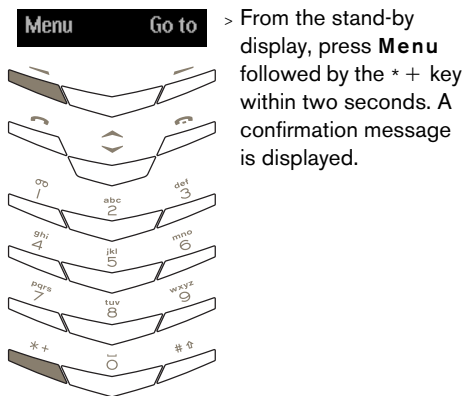

- > When the keypad is locked, a key icon appears below the signal strength indicator.



When the keypad is locked, calls may be possible to the emergency number programmed into your Vertu phone, for example 112, 911 or another official emergency number.

- > Key in the emergency number.
- > Press **SEND**.

The emergency number is displayed only after you have keyed in its last digit.

Receiving a call

Your Vertu phone keypad lock is automatically suspended when you receive an incoming call

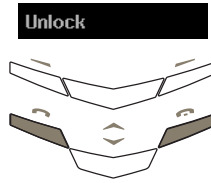

- > Press the **SEND** key to answer a call when the keypad is locked.
- > During the call your Vertu phone can be operated as normal.
- > Press the **END** key to end a call or reject an incoming call.

The keypad reverts to locked when you end the call.

UNLOCKING THE KEYPAD

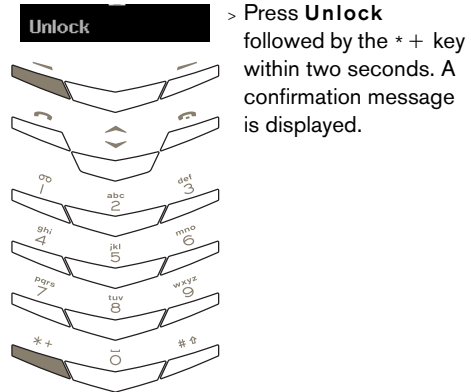

MENU NAVIGATION

Your Vertu phone offers an extensive range of functions that are accessed through a series of menus. The most commonly used features are assigned to the shortcuts menu to enable rapid access to the function.

USING THE MENUS

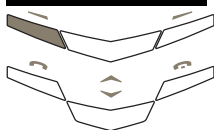

- > From the stand-by display, press **Menu** to navigate to a function using the menus.
- > Use the **SCROLL** keys to scroll to the desired menu.
- > Press **Select** to enter the menu and view the submenu.

The menus are grouped into categories relating to a set of functions:

Messages Allows you to write, send, receive and read messages. Your Vertu phone supports multiple message formats such as text, multimedia, voice and e-mail.



Call register Allows you to view information about voice and data calls that you have missed, received and made.



Profiles Allows you to manage the settings for audible and vibration alerts. Six different profiles are available on your Vertu phone.



Settings Allows you to set up your Vertu phone to your preference. In addition to basic phone settings, you can change the display, time, shortcuts, connectivity, calls, and security settings.



Contacts Allows you to manage your personal phone book including options like assigning speed dials and voice tags to your entries.



Additions Enables you to access your multimedia files, use the media player, voice recorder, custom applications and browser.



Organiser Allows you to view your calendar, set reminders for forthcoming events or dates, add notes, review your to-do list and set the alarm clock.



SIM services May offer additional features or facilities such as online banking or sports information. The name displayed may differ and the feature's availability is at the discretion of your service provider. Many providers disable this feature.



When navigating through the menus and submenus, press **Back** or **Exit** to return to the previous menu or submenu without saving changes. At any time, press the **END** key to return to the stand-by display without saving changes.

USING SHORTCUTS



- > From the stand-by display, press **Go to** to access a function from the shortcut list.
- > Use the **SCROLL** keys to scroll to the desired function.
- > Press **Select** to enter the function directly.

The following information explains how to use the default shortcuts. You can customisethe shortcut list for easy access to your favourite functions. For more information see the Reference Manual.

Names

The **Names** shortcut provides quick access to the Contacts function. See "Contacts" on page 14 for more information.

Alarm clock

You can use the **Alarm clock** shortcut to set an audible alert at a specified time during the next 24 hours. The alarm will sound, provided the time has been set on your Vertu phone and the battery is sufficiently charged.



If you set the alarm clock and then switch off your Vertu phone, the alarm will still sound at the time set.

..



- > Use the **SCROLL** keys to scroll to **Alarm clock** and press **Select**.
- > Key in the alarm time using the **NUMBER** keys, using the **SCROLL** keys to toggle between hour and minutes.
- > Press **OK**.
- > If the clock is set to use 12-hour format, Scroll to **am** or **pm** and press **OK**.

A confirmation message is displayed and an  icon shows that the alarm is set.

Calculator

The **Calculator** shortcut enables you to perform simple calculations using your Vertu phone. You can add, subtract, multiply, divide, square, square root and convert currency values.

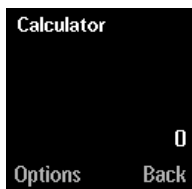

- > Use the **SCROLL** keys to scroll to **Calculator** and press **Select**.
- > Key in the first number of the calculation. To obtain a decimal point, press the **#†** key.
- > Either, press **Options** and select the arithmetical operator from the list and press **Select**. Or, press the ***+** key to select a different operator with each key press.
- > Key in the second number of your calculation.
- > For a total, press **Options**, and select **Equals**.



The calculator has a limited accuracy and rounding errors may occur.

Gallery

Use the **Gallery** shortcut to browse through the multimedia files stored on your Vertu phone.



- > Use the **SCROLL** keys to scroll to **Gallery** and press **Select**.
- > Use the **SCROLL** keys to scroll to the appropriate multimedia folder and press **Options**. For example to locate the files created by the Voice Recorder, scroll to **Recordings**.
- > Use the **SCROLL** keys to highlight **Open** and press **Select**.
- > Use the **SCROLL** keys to scroll through the files of the selected type, press **Options** to select an action to perform on the file and press **Select**. For example, scroll to **Open** to open the file in the Media Player.



Some media files, such as ringing tunes, are copyright protected and can only be manipulated in accordance with their licence terms. For example, they cannot be copied, edited or moved.

See the Reference Manual for more information about organising your media files and sending them as attachments to multimedia messages.

Make a to-do

Select the **Make a to-do** shortcut to add an item to your to-do list.

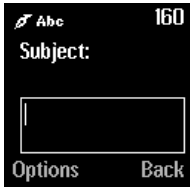

- > Use the **SCROLL** keys to scroll to **Make a to-do** and press **Select**.
- > Key in the subject of your to-do item and press **Options**.
- > Use the **SCROLL** keys to highlight **Save** and press **Select**.
- > Set the priority of your item as **High**, **Medium** or **Low** and press **Select**. The to-do note is saved to the to-do list in your phone's organiser.

Inbox

The **Inbox** shortcut provides quick access to the text message inbox function. See "Text Messages" on page 15 for more information.

Create msg.

The **Create msg.** shortcut provides quick access to the text message creation function. See "Sending Text Messages" on page 15 for more information.

CONTACTS

Your Vertu phone's directory can hold up to 1,000 entries. See the Reference Manual for more information about adding and deleting contacts and creating speed dials and voice tags.

QUICK STORE

To store names and numbers quickly, follow the procedure below:



- > From the stand-by display, use the **NUMBER** keys to key in the phone number.
- > Press **Options**. The **Save** item is highlighted.
- > Press **Select**.



- > Key in the name, for example "**Maria**", as follows:
- > Press the **6** key for "**M**".
- > Press the **2** key for "**a**".
- > Press the **7** key three times for "**r**".
- > Press the **4** key three times for "**i**".
- > Press the **2** key for "**a**".
- > Press **Clear** at any time to erase the character before the cursor.
- > Press **OK**. A confirmation message is displayed.

QUICK SEARCH

To search for names and numbers quickly, follow the procedure below:



- > From the stand-by display, press a **SCROLL** key.
- > Key in the first letter of the desired name, for example "M". The first name starting with that letter is highlighted.



- > Scroll to the desired name.
- > If the name in your Contacts directory has multiple numbers associated with it, press **Details** and scroll to the desired number.



- > Press the **SEND** key to call the number.

TEXT MESSAGES

The **Messages** feature allows you to write, send, receive and store text messages. See the Reference Manual for a detailed explanation of all text message options and how to use predictive text input, a feature that allows you to key in text messages quickly. The following example gives an overview of how to use the **Messages** feature using basic text input.

READING TEXT MESSAGES

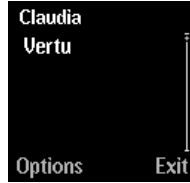

When you receive a text message, an information note and an envelope icon appear. By default a received message is accompanied by an audible alert.

- > Press **Show**.
- > Press the lower **SCROLL** key to read the whole message.

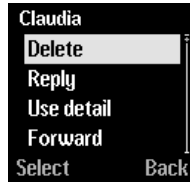

If the text message is not required, erase it as follows:

- > Press **Options**. **Delete** is highlighted.
- > Press **Select**.
- > Press **OK**. A confirmation message is displayed.

SENDING TEXT MESSAGES



- > From the stand-by display, press **Menu**. **Messages** appears.
- > Press **Select**. **Text messages** is highlighted.
- > Press **Select**. **Create message** is highlighted.
- > Press **Select**.



The first letter of a sentence is automatically capitalised.

Key in your text message, for example "Vertu", as follows:

- > Press the 8 key three times for "V".
- > Press the 3 key twice for "e".
- > Press the 7 key three times for "r".
- > Press the 8 key for "t".
- > Press the 8 key twice for "u".
- > Press the 0 (ZERO) key to insert a space.

Press **Clear** at any time to erase the character to the left of the cursor.



- > Press **Options**. **Send** is highlighted.
- > Press **Select**.
- > If prompted, key in your message centre number and press **OK**.
- > Key in the recipient's phone number.
- > Press **OK**. A confirmation message is displayed.



When you send a text message, your Vertu phone displays a confirmation message to confirm that the text message has been sent to the message centre. It is not an indication that the text message has been received at the intended destination.

For more information about messaging services and your message centre number contact your service provider.

VERTU CONCIERGE

Vertu Concierge is an exclusive service for people who believe that quality matters. Our aim is to bring you only the very best, whether it be music, art, travel or food.

Vertu Concierge provides you with a highly personalised range of services:

- > *Lifestyle services, for example, restaurant recommendations and reservations, travel assistance, and tickets for theatre shows, concerts or sporting events.*
- > *Solving everyday practical problems such as finding a reputable plumber or tracking down a gift.*
- > *Assistance with using your Vertu phone.*

When you connect to Vertu Concierge, you can speak directly to a team of multilingual specialists who are available 24 hours a day, 7 days a week to offer personalised assistance.

If you have not already registered your personal details and the purchase of your phone (using www.verturegistration.com or the **CONCIERGE** key) you will be asked to register during your first call to Vertu Concierge.

CALLING VERTU CONCIERGE

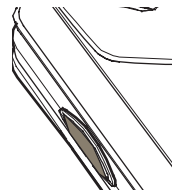

The **CONCIERGE** key is located on the left side of your Vertu phone as shown.



- > Press and hold the **CONCIERGE** key for approximately two seconds, until **Concierge** appears.
- > Press **Call** or the **SEND** key to call Vertu Concierge.
- > Press the **END** key when you have finished the call.

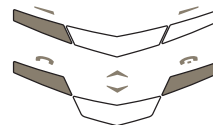

If you are unable to reach Vertu Concierge using the **CONCIERGE** key, call +448707375535.

ACCESSORIES

This section shows how to use the individual accessories with your Vertu phone.

- > Headset
- > Charger and battery
- > Vehicle Charger
- > Data Cable



Keep all parts out of reach of small children.

Use only batteries, chargers and accessories approved by Vertu for use with this particular phone model. The use of any other types may invalidate any approval or warranty applying to the phone and may be dangerous.

When you disconnect an accessory cable from your Vertu phone, hold and pull the connector at the end of the cable, not the cable itself.

To optimise the performance and lifetime of your accessories, and protect your warranty coverage, observe the following handling and usage precautions:

- > Keep dry. Precipitation, humidity and all types of liquids or moisture can contain minerals that will corrode electronic circuits.
- > Do not use or store in dirty or dusty areas.
- > Do not attempt to open.
- > Do not drop, knock or shake. Rough handling can break fine mechanics.
- > Do not store in hot areas. High temperatures can shorten the life of electronic devices and damage batteries.
- > Do not store in cold areas.
- > Do not use harsh chemicals, cleaning solvents or strong detergents to clean.
- > Do not paint.

For more information about the availability of accessories approved for use with your Vertu phone, contact Vertu Concierge.

HEADSET



We recommend using the headset with the Vertu leather holster case, available as a separate Vertu Collections product.

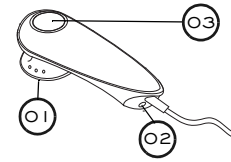

- 01 earpiece
- 02 microphone
- 03 ANSWER/END button

To connect the headset to your Vertu phone:

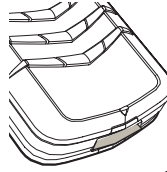

- > Insert the headset connector into the bottom of your Vertu phone as shown.

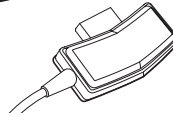

The headset icon appears below the signal strength indicator.

- > Place the earpiece in your ear.



- > Position the microphone (the pointed end) as shown.
- > Use the VOLUME key on your Vertu phone to adjust to a comfortable listening level.
- > Press the ANSWER/END button (03) to answer an incoming call.
- > Press the ANSWER/END button to end a call.

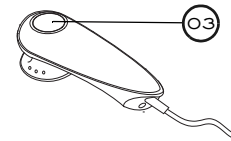

When the headset is connected, you can configure your Vertu phone to answer calls automatically. See the Reference Manual for more information.

CHARGER

The charger recharges your Vertu phone battery quickly and safely by means of a powered AC outlet.

The charger supplied with your Vertu phone should be appropriate for your region. However, you should always check that electrical rating of the AC outlet is appropriate for the charger before you attempt to plug it in.



Never attempt to use a charger if it has been damaged. Contact Vertu Concierge to obtain a replacement.

Attaching the Cable to the Phone Connector



- > Attach the charger cable by inserting it into the adaptor body.

CHARGING YOUR BATTERY

The battery for your Vertu phone is rechargeable and requires charging at regular intervals.



Only use the approved charger and battery designed specifically for your Vertu phone.

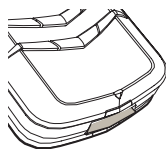

- > Ensure that you have attached the charger cable to the correct charger.
- > Insert the charger connector into the bottom of your Vertu phone as shown.

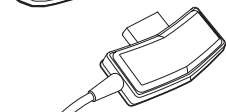

- > Connect the charger body to a powered AC outlet.
- > After a few seconds, the battery indicator animates and a confirmation message is displayed if your Vertu phone is switched on.

If the battery is fully discharged it may take a few moments before the charging indicator appears on the display.

When the battery is fully charged, the battery charge indicator stops animating and, if your Vertu phone is switched on, a confirmation message is briefly displayed.

If your Vertu phone is not charging, try the following:

- > Disconnect the charger from the AC outlet.
- > Check that the electrical rating of the AC outlet is compatible with your charger.
- > Verify that the AC outlet has power and that it is switched on. For example, in many hotel rooms, AC outlets are used for lighting and may be switched on and off from remote locations in the room.
- > Wait for at least 10 seconds and then re-connect the charger to the AC outlet.
- > Use another nearby AC outlet that you know is providing power.
- > If charging still fails, contact Vertu Concierge for further advice.

The vibrating alert is disabled while the charger is connected to your Vertu phone.

When you want to stop charging your battery, for example when charging is complete:

- > Disconnect the charger from the AC outlet.
- > Disconnect the charger from your Vertu phone by pulling the charger connector – do not pull the cable or adaptor body.

The charger can be used in conjunction with the data cable. For more information see “Connecting the data cable” on page 21.

BATTERY



Do not dispose of batteries in a fire and always dispose of a battery according to local regulations. Do not dispose of as household waste.

Always switch the phone off and disconnect the charger before removing the battery.

Removing the battery

- > Switch off your Vertu phone and disconnect the charger and any accessories.

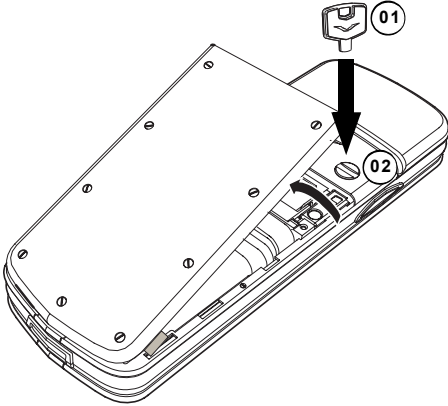

- > With the back of your Vertu phone facing you, position the back cover release key (01) very carefully into the slot of the locking screw. Ensure the key does not slip out of the slot.
- > Turn the locking screw (02) a quarter of a turn anti-clockwise, and gently lift off the back cover as shown. If you accidentally remove the back cover while the phone is switched on, the phone will automatically switch off.

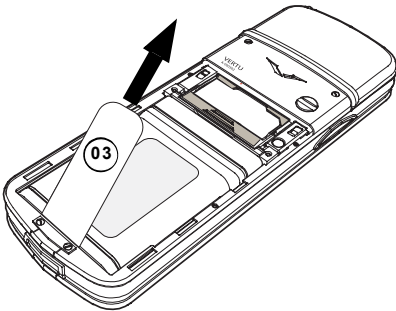

- > Hold the release tab (03) and pull upwards to remove the battery from your Vertu phone.

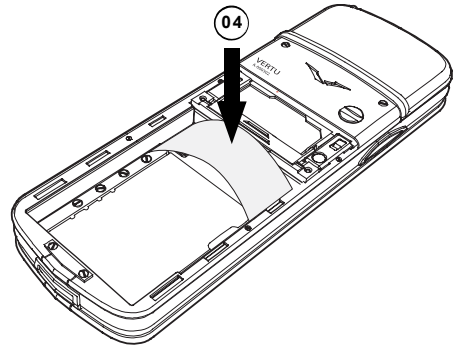

- > If you do not re-insert the battery or insert another battery immediately, insert the plastic placeholder (04) before replacing the back cover. This will make it easier to remove the back cover.



Your Vertu phone will lose its date and time settings if the battery is removed for more than approximately 120 minutes.

See "Battery Information" on page 24 for more information about your battery.

Installing the battery

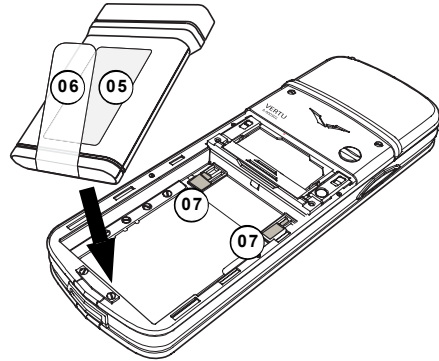

- > Insert the battery (05) bottom end first with the release tab (06) facing up from the rear of the phone. Ensure that the contacts on the top end of the battery align with the contact points (07) inside the battery compartment.

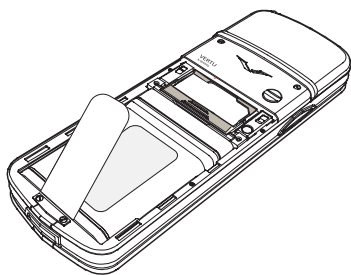

- > Ensure that the battery is seated correctly before replacing the back cover.

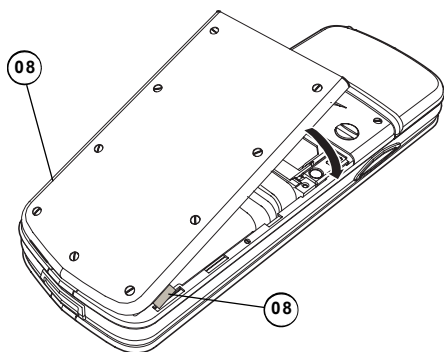

- > To replace the back cover, locate lugs (08) as shown.
- > Pivot the back cover into position until it clicks into place. The cover should close tightly using only light pressure – do not force it closed! If the cover does not close easily, remove it and check the battery is correctly inserted.

See "Battery Information" on page 24 for more information about your battery.

VEHICLE CHARGER

The vehicle charger recharges your Vertu phone battery quickly and safely from a standard 12 or 24 volt (DC) vehicle cigarette lighter outlet.



Only use the vehicle charger specifically designed for use with your Vertu phone.

Never attempt to use a vehicle charger if it has been damaged.

Only use the vehicle charger in a stationary vehicle.

The time taken to charge your battery depends on its existing charge. It takes approximately 90

minutes to charge the battery. You can use your phone normally during the charging process.

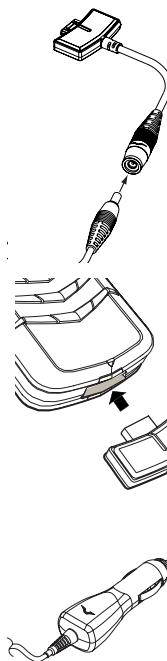

- > Attach the charger cable into the adaptor body.
- > Insert the charger connector into the bottom of your Vertu phone as shown.
- > Connect the charger to the powered cigarette lighter outlet.
- > The green indicator light will illuminate to show the charger is connected to the power outlet. A confirmation message is displayed if your Vertu phone is switched on.

Some cigarette lighter sockets are only powered when the vehicle ignition is switched on.

The vibrating alert is disabled while the charger is connected to your Vertu phone.

When the battery is fully charged, the battery charge indicator stops animating. Disconnect the car charger from the cigarette lighter outlet before you unplug it from your Vertu phone.

DATA CABLE

The data cable, when used in conjunction with a compatible computer, allows you to use the Vertu Data Suite software supplied on the CD-ROM to manage your phone. The data cable also enables you to use your Vertu phone as a modem to transfer data, or send and receive faxes. For more information on using your Vertu phone as a modem contact your service provider.

You will need to install Vertu Data Suite in order to use your Vertu phone as a modem. For more information on installing Vertu PC Suite see "CD-ROM" on page 21.

Connecting the data cable

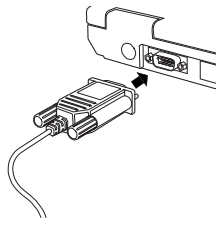

> Connect the end of the data cable with the screws attached to the Serial (COM) port of your compatible computer, ensuring it is seated properly.

> Tighten the screws.

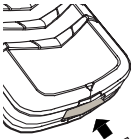

> Ensure your Vertu phone is switched on.

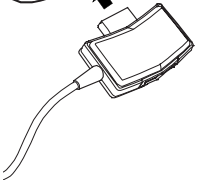

> Insert the data cable connector into the bottom of your Vertu phone as shown. (Your data cable connector may be slightly different to the one shown.)



> If necessary, with the data cable inserted, you can also connect the charger to your Vertu phone.

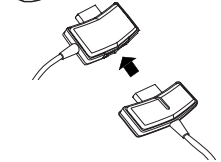

> Plug the charger connector into the back of the data cable connector as shown.



The headset will not operate if the headset connector is plugged into the back of the data cable connector.

CD-ROM

The CD-ROM provided with your Vertu phone contains an electronic version of the Reference Manual, the Vertu PC Suite software, and instructions on setting up your Vertu phone for MMS, browsing and email.

Vertu PC Suite includes four applications that extend the functionality of your Vertu phone.

APPLICATIONS

<i>Content Copier</i>	Allows you to back up and restore phone data, such as the Contacts and Organiser, using a compatible computer.
-----------------------	--

<i>Synchronisation</i>	Allows you to synchronise Contacts entries and Organiser notes in your Vertu phone with Windows® applications, such as Microsoft® Outlook® and Outlook® Express.
------------------------	--

<i>Modem Connectivity</i>	Allows you to use your Vertu phone as a modem for data calls, when connected to a compatible computer.
---------------------------	--

<i>Phone Browser</i>	Allows you to view the contents of the Gallery folder, of your Vertu phone, on a compatible computer. You can browse picture and audio files and transfer files between your Vertu phone and a compatible computer.
----------------------	---

MINIMUM SPECIFICATIONS

The Vertu CD-ROM will only work on a compatible computer with a CD-ROM drive and with at least the minimum specifications listed below.

Operating System	Microsoft® Windows® 2000; Microsoft® Windows® XP Home; Microsoft® Windows® XP Pro
------------------	---

Processor	Intel® Pentium® III 333 MHz or equivalent
-----------	---

Graphic	1024 x 768 pixels 256 colours
---------	----------------------------------

Memory	256 MB
--------	--------

Free Disk Space	250 MB
-----------------	--------

STARTING THE CD-ROM

- > Ensure your compatible computer complies with at least the minimum specifications listed above.
- > Insert your Vertu CD-ROM into the CD-ROM drive.
- > Select your desired language. The introduction plays.

If the CD-ROM application does not start automatically, follow the procedure below:

- > Double-click on the My Computer icon on the desktop and locate your CD-ROM drive.
- > Double-click on the Vertu CD-ROM icon, which has replaced your usual CD-ROM icon.
- > If the application does not start automatically, double-click on the Vertu.exe file.
- > Select your desired language. The introduction plays.

INSTALLING VERTU PC SUITE

- > Start the CD-ROM as described above.
- > Click on the INSTALL NOW button.
- > Follow the on-screen instructions to complete the installation.

VIEWING THE ELECTRONIC REFERENCE MANUAL

- > Start the CD-ROM as described above.
- > Click on the LAUNCH PDF button.
- > Follow the on-screen instructions to view the Reference Manual in your desired language.

SETTING UP MMS, BROWSING AND EMAIL

- > Start the CD-ROM as described above.
- > Click on the ORDER SETTINGS button.

CARE AND MAINTENANCE

Your Vertu products have been crafted from some of the finest materials and care should be taken to keep them in good condition.



Damage caused to your Vertu phone by failing to observe these care instructions is not covered by the warranty.

CERAMICS AND SAPPHIRE

Ceramics and sapphire are very hard materials but are also brittle and can be scratched by harder materials or objects. Furthermore, they can be damaged if dropped.

Avoid the following:

- > *Contact with other hard objects and materials such as diamond jewellery (particularly rings and earrings), nail files, sand paper, abrasives, quartz crystals, metal oxides, nitrides and carbides.*
- > *Dropping or knocking the product on hard surfaces.*
- > *Repeated rubbing against hard surfaces.*

LEATHER

All Vertu leather products are made by expert craftsmen. Each leather hide is unique and has its own natural characteristics which should be considered part of the individuality of fine leather and not as imperfections or flaws. All leather can be damaged and should be treated with care.

Avoid the following:

- > *Prolonged exposure to water and high humidity.*
- > *Dropping, rubbing or knocking on hard surfaces.*
- > *Exposure to extreme temperatures.*
- > *Contact with oily substances, make-up and solvents.*

METAL

Vertu metals are finished to a high standard and care needs to be taken to maintain their appearance. Protect in soft cases where possible and polish only with a Vertu recommended polishing cloth.

Avoid the following:



- > *Contact with chemicals such as solvents, alkaline and acid solutions, cola-based drinks and prolonged exposure to salt water. Wipe with a clean, soft cloth as soon as possible if contact occurs.*
- > *Contact with sharp objects.*
- > *Dropping or knocking against hard surfaces.*

HALLMARKS

If you have a gold or platinum Vertu phone, hallmarks are stamped as shown below to authenticate the precious metals used. Each precious metal is tested to ensure that the purity of the alloy conforms to the exacting standards of the European Convention Mark under the jurisdiction of the Swiss Assay Office.

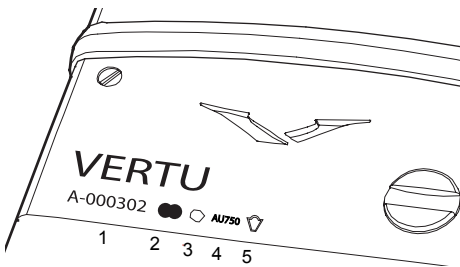
The hallmark is made up of several stamps, which each have an individual meaning. It is located on the backplate next to the serial number.



- A-000302 1. Serial number.
-  2. Common control mark denoting the European Convention Mark – 750 (18 carat gold) or 950 (platinum) in scales.
-  3. St. Bernard dog's head – Swiss Assay Office mark.
- AU750 4. The fineness (purity) mark – AU 750 (18 carat gold) or PT950 (platinum).
-  5. Sponsor's mark denoting the Vertu brand.

MICROFIBRE POLISHING CLOTH

The microfibre polishing cloth is hand-washable and is provided for polishing the surfaces and removing fingerprints. The surface **MUST** be free from dust before polishing as dust particles may damage metal surfaces when polished.

-  *Jewellery cleaner must not be used as this may affect the mechanics of the product and invalidate the warranty.*

GENERAL CARE TIPS

- > *Keep your Vertu phone dry. Precipitation, humidity and all types of liquids or moisture can contain minerals that will corrode electronic circuits. If your device does get wet, remove the battery and allow the device to dry completely before replacing it.*
- > *Do not use or store your Vertu phone in dusty, dirty areas. Its moving parts and electronic components can be damaged.*
- > *Do not store your Vertu phone in hot areas. High temperatures can shorten the life of electronic components, damage batteries and warp/melt certain plastics.*
- > *Do not store your Vertu phone in cold areas. When your Vertu phone returns to its normal temperature, moisture can form inside and damage the electronics.*
- > *Do not attempt to open your Vertu phone other than as instructed in this guide.*
- > *Do not drop, knock, or shake your Vertu phone. Rough handling can break internal circuit boards and fine mechanics.*

BATTERY INFORMATION

Your Vertu phone is powered by a rechargeable battery. The full performance of a new battery is achieved only after two or three complete charge and discharge cycles. The battery can be charged and discharged hundreds of times but it will eventually wear out. If you notice that the talk and stand-by times are much shorter than normal, you may need a new battery. Contact Vertu Concierge to acquire a Vertu approved battery. Use only Vertu approved batteries and recharge your battery using only the Vertu approved chargers designed for your Vertu phone.

CHARGING AND DISCHARGING

Unplug the charger from the AC outlet and your Vertu phone when not in use. Do not leave your Vertu phone connected to a charger. Overcharging the battery may shorten its lifetime. If left unused, a fully charged battery will lose its charge over time. Temperature extremes can affect the ability of your battery to charge.

BATTERY CARE AND SAFETY

Use the battery only for its intended purpose. Never use any charger or battery that is damaged.

Do not short-circuit the battery. Accidental short-circuiting can occur when a metallic object such as a coin, clip, or pen causes direct connection of the positive (+) and negative (-) terminals of the battery (the metal strips on the battery.) This might happen, for example, when you carry a spare battery in your pocket, purse or bag. Short-circuiting the terminals may damage the battery and the connecting object.

Leaving the battery in hot or cold places, such as in a closed car in summer or winter conditions, will reduce the capacity and lifetime of the battery. Always try to keep the battery between 15°C and 25°C (59°F and 77°F). If your battery is very hot or extremely cold, your Vertu phone may not work temporarily, even if the battery is fully charged. Battery performance is particularly limited in temperatures well below freezing.



Never dispose of batteries in a fire.

Always dispose of batteries according to local regulations. Please recycle when possible. Do not dispose of batteries as household waste.

SAFETY INFORMATION

TRAFFIC SAFETY

Do not use a hand-held telephone while driving a vehicle. If using a hand-held phone park the vehicle before using the phone in any way. Do not place the phone on the passenger seat or where it can break loose in a collision or sudden stop.

Remember road safety always comes first!

OPERATING ENVIRONMENT

Remember to follow any special regulations in force in any area and always switch off your phone whenever it is forbidden to use it, or when it may cause interference or danger.

When connecting the phone or any accessory to another device, read its user's guide for detailed safety instructions. Do not connect incompatible products.

As with other mobile radio transmitting equipment, users are advised that for the satisfactory operation of the equipment and for the safety of personnel, it is recommended that the equipment should only be used in the normal operating position. When the phone is on and being worn on the body, always use an approved carrying case.

Use only the supplied or approved parts. Unauthorised antennas, modifications or attachments could damage the phone and may violate regulations governing radio devices.

ELECTRONIC DEVICES

Most modern electronic equipment is shielded from radio frequency (RF) signals. However, certain electronic equipment may not be shielded against the RF signals from your wireless phone.

PACEMAKERS

Pacemaker manufacturers recommend that a minimum separation of 15 cm (6 inches) be maintained between a hand-held wireless phone and a pacemaker to avoid potential interference with the pacemaker. These recommendations are consistent with the independent research by and recommendations of Wireless Technology Research.

Persons with pacemakers:

- > *Should always keep the phone more than 15 cm (6 inches) from their pacemaker when the phone is switched on;*
- > *Should not carry the phone in a breast pocket;*
- > *Should use the ear opposite the pacemaker to minimize the potential for interference.*

If you have any reason to suspect that interference is taking place, switch off your phone immediately.

HEARING AIDS

Some wireless phones may interfere with some hearing aids. In the event of such interference, consult your service provider.

OTHER MEDICAL DEVICES

Operation of any radio transmitting equipment, including wireless phones, may interfere with the functionality of inadequately protected medical devices. Consult a physician or the manufacturer of the medical device to determine if they are adequately shielded from external RF energy or if you have any questions.

Switch off your phone in health care facilities when any regulations posted in these areas instruct you to do so. Hospitals or health care facilities may be using equipment that could be sensitive to external RF energy.

VEHICLES

RF signals may affect improperly installed or inadequately shielded electronic systems in motor vehicles (e.g. electronic fuel injection systems, electronic anti-skid (anti-lock) braking systems, electronic speed control systems, air bag systems).

Check with the manufacturer or its representative regarding your vehicle. You should also consult the manufacturer of any equipment that has been added to your vehicle.

Do not store or carry flammable liquids, gases or explosive materials in the same compartment as the phone, its parts or accessories.

For vehicles equipped with an air bag, remember that an air bag inflates with great force. Do not place objects, including both installed or portable wireless equipment in the area over the air bag or in the air bag deployment area. If in-vehicle wireless equipment is improperly installed and the air bag inflates, serious injury could result.

AIRCRAFT

Switch off your phone before boarding an aircraft. The use of wireless telephones in an aircraft may be dangerous to the operation of the aircraft, disrupt the wireless telephone network and may be illegal. In the United States, FCC regulations prohibit using your Vertu phone while in the air.

Failure to observe these instructions may lead to suspension or denial of telephone services to the offender, or legal action or both.

POSTED FACILITIES

Switch your phone off in any facility where posted notices so require.

POTENTIALLY EXPLOSIVE ATMOSPHERES

Switch off your phone when in any area with a potentially explosive atmosphere and obey all signs and instructions. Sparks in such areas could cause an explosion or fire resulting in bodily injury or even death.

Users are advised to switch off the phone when at a refuelling point (service station). Users are reminded of the need to observe restrictions on the use of radio equipment in fuel depots (fuel storage and distribution areas), chemical plants or where blasting operations are in progress.

Areas with a potentially explosive atmosphere are often but not always clearly marked. They include below deck on boats; chemical transfer or storage facilities; vehicles using liquified petroleum gas (such as propane or butane); areas where the air contains chemicals or particles, such as grain, dust or metal powders; and any other area where you would normally be advised to turn off your vehicle engine.

WATER RESISTANCE



Your Vertu phone is not water resistant. Keep it dry.

If your Vertu phone is accidentally splashed with water, ensure you dry it completely before removing the back cover.

The SIM card and battery are not water resistant.

Never charge your Vertu phone when the connector at the bottom of the phone is damp or wet. Chargers must only be used in dry conditions. They should never be used when damp or wet.

Never use accessories when your Vertu phone is wet or damp.



Make sure the interior of your Vertu phone and the back cover seals are dry, clean, and free of any foreign objects before you replace the back cover.

ANTENNA

Your Vertu phone has an internal antenna. As with any other radio transmitting device, do not touch the antenna unnecessarily when the phone is switched on. Contact with the antenna affects call quality and may cause the phone to operate at a higher power level than otherwise needed.

Avoiding contact with the antenna during a call optimises the antenna performance and the talk time of your Vertu phone.

SPECIFICATIONS

STAINLESS

Volume	76cc
Weight	173g
Length	122mm
Width	42mm
Thickness	15.5mm

GOLD

Volume	76cc
Weight	198g
Length	122mm
Width	42mm
Thickness	15.5mm

PLATINUM

Volume	76cc
Weight	215g
Length	122mm
Width	42mm
Thickness	15.5mm

POWER MANAGEMENT

BLZ-2

Battery Capacity (mAh)	1000mAh
Maximum talk time	(n/a Mercedes pls provide actuals)
Maximum stand-by	(n/a Mercedes pls provide actuals)

**Variation in operating time will occur depending on usage and location.

WARRANTY

VERTU TWO-YEAR LIMITED INTERNATIONAL
WARRANTY FOR CELLULAR PHONE

THIS LIMITED WARRANTY SHALL NEITHER EXCLUDE NOR LIMIT (I) ANY MANDATORY STATUTORY RIGHTS OF THE CLIENT OR (II) ANY OF THE CLIENT'S RIGHTS AGAINST THE SELLER/DEALER OF THE PRODUCT.

VERTU LTD ("Vertu") warrants that this cellular phone ("Product") is free from defects in material and workmanship according to the following terms and conditions:

1. The Limited Warranty for the Product extends for TWO (2) years beginning on the date of original purchase or delivery of the Product, whichever is the later. In case of a change of owner/user, such warranty period shall continue for the remaining part of the twenty-four (24) month period and otherwise remain unaffected.
2. During the period of the Limited Warranty, Vertu will repair, modify or replace, at Vertu's sole option, any defective parts, or any parts that will not properly operate for their intended use with new or refurbished replacement items if such repair or replacement is needed because of product malfunction or failure during normal usage. No charge will be made to the Client for the repair or replacement of any such parts. Vertu will also pay for the labour charges incurred by Vertu in repairing or replacing the defective parts. The repaired Product will be warranted for the balance of the original warranty period or for ninety (90) days from the date of repair, whichever is longer. This Limited Warranty does not cover damage to or defects in (other than manufacturing defects) appearance, cosmetic, decorative or structural items and any non-operative parts. Vertu's limit of liability under the Limited Warranty shall be the price paid by the Client for the Product less a reasonable amount for usage. These remedies are the Client's exclusive remedies for breach of this Limited Warranty.
3. Upon request from Vertu, the Client must prove the date of the original purchase or delivery of the Product by producing a legible and non-modified original certificate of authenticity which clearly indicates the name and address of an authorised retailer, the date and place of purchase/delivery, the product type and the IMEI or serial number of the Product, a bill of sale or a dated receipt which contains the same information.
4. Vertu shall bear the cost of shipping the Product to the location from which the Client handed over the Product to Vertu (or its representatives) after the completion of service under this Limited Warranty.
5. The Client shall have no coverage or benefits under this Limited Warranty if any of the following conditions are applicable:
 - a) The Product has been subject to abnormal use, abnormal conditions, improper storage, exposure to moisture or dampness, spillage of food or liquid, exposure to chemical agents, unauthorised modifications, unauthorised connections, unauthorised repair, rough handling, misuse, neglect, abuse, accident, alteration, improper installation, or other acts which are not the fault of Vertu, including without limitation damage caused by shipping, dropping the Product, deterioration of consumable parts, such as batteries which by their nature have a limited lifecycle, and breakage or damage to antennas.
 - b) The Product has been damaged from external causes such as collision with an object, or from fire, flooding, sand, dirt, windstorm, lightning, earthquake or damage from exposure to thermal, environmental or weather conditions, an Act of God, or battery leakage, theft, blown fuse, or improper use of any electrical source, damage caused by computer or internet viruses, bugs, worms, Trojan Horses, cancel bots or damage caused by the connection to other products not recommended for interconnection by Vertu.
 - c) The Customer Service Department at Vertu was not advised by the Client in writing of the alleged defect or malfunction of the Product within thirty (30) days after the expiration of the applicable warranty period.
 - d) The Product was not returned to Vertu or its authorised retailer within thirty (30) days after the appearance of the defect within the warranty period.
 - e) The Product serial number plate or the accessory data code has been removed, defaced, altered or is illegible.
 - f) The defect or damage was caused by the defective function of the cellular network system or by inadequate signal reception by the external antenna.
 - g) The defect was caused by the Product being used with or connected to an accessory not manufactured and supplied by Vertu or used other than for its intended use.
 - h) The battery was short-circuited or the seals of the battery enclosure or cells are broken or show evidence of tampering or the battery was used in equipment other than that for which it has been specified.
 - i) The Product software needs to be updated due to changes in cellular network parameters.
 - j) The defect or damage was as a result of general wear and tear incurred in normal usage of the Product.
6. If a problem develops during the period of the Limited Warranty, the following procedure will apply:
 - a) The Client shall return the Product to the place of purchase for repair or replacement processing or if this is not convenient because of distance (more than 50 miles/80 km) or for other good cause, the Client may contact Vertu Concierge.
 - b) The Client shall bear the costs of transporting the Product to the relevant Vertu service location, with transport and insurance charges prepaid.
 - c) Subject to Clause 6(e), the Client will be billed for any parts or labour charges not covered by this Limited Warranty.

- d) Vertu will repair or authorise the repair of the Product under the Limited Warranty within 30 days after receipt of the Product by Vertu or a Vertu authorised service centre, or within an extended period as may be notified by Vertu to Client due to the nature of the repair ("Timeframe"). If Vertu cannot repair within the Timeframe, or after a reasonable number of attempts to repair the same defect, Vertu at its sole option, will provide a replacement Product or refund the purchase price of the Product less a reasonable amount for usage.
- e) If the Product is returned to the Customer Service Department at Vertu during the period of the Limited Warranty, but the problem with the Product is not covered under the terms and conditions of this Limited Warranty, the Client will be notified and given an estimate of the charges the Client must pay to have the Product repaired, with all shipping charges billed to the Client. If the estimate is refused, the Product will be returned freight collect. If the Product is returned to the Customer Service Department at Vertu after the expiration of the warranty period, Vertu's normal service policies shall apply and the Client will be responsible for all shipping charges.
7. TO THE FULLEST EXTENT PERMITTED BY LAW, THE WARRANTIES AND CONDITIONS STATED IN THIS LIMITED WARRANTY ARE IN LIEU OF ALL OTHER CONDITIONS, WARRANTIES OR OTHER TERMS CONCERNING THE SUPPLY OR PURPORTED SUPPLY OF, OR FAILURE TO SUPPLY OR DELAY IN SUPPLYING THE PRODUCT WHICH MIGHT, BUT FOR THE AFFECT OF THIS CLAUSE 7, HAVE EFFECT BETWEEN VERTU AND THE CLIENT OR WOULD OTHERWISE BE IMPLIED OR INCORPORATED INTO THIS LIMITED WARRANTY OR ANY COLLATERAL CONTRACT, WHETHER BY STATUTE, COMMON LAW OR OTHERWISE, ALL OF WHICH ARE HEREBY EXCLUDED (INCLUDING WITHOUT LIMITATION, THE IMPLIED CONDITIONS, WARRANTIES OR OTHER TERMS AS TO SATISFACTORY QUALITY OR FITNESS FOR PURPOSE).
8. VERTU SHALL NOT BE LIABLE FOR LOSS OR DAMAGE, WHETHER SPECIAL, INDIRECT, INCIDENTAL OR CONSEQUENTIAL, INCLUDING BUT NOT LIMITED TO ANY OF THE FOLLOWING LOSSES OR DAMAGE (WHETHER SUCH LOSSES OR DAMAGE WERE FORESEEN, FORESEEABLE, KNOWN OR OTHERWISE):
- LOSS OF ANTICIPATED BENEFITS OR PROFITS.
 - LOSS OF ACTUAL OR ANTICIPATED SAVINGS.
 - PUNITIVE, SPECIAL OR CONSEQUENTIAL DAMAGES.
 - THIRD PARTY CLAIMS.
 - LOSS OF USE OF THE PRODUCT OR ANY ASSOCIATED EQUIPMENT OR FACILITIES.
 - DOWNTIME OR LOSS OF BUSINESS.
 - LOSS OF OPPORTUNITY.
 - LOSS OF GOODWILL.
- LOSS OF REPUTATION.
 - LOSS OF OR DAMAGE TO OR CORRUPTION OF DATA.
- Vertu does not warrant uninterrupted or error free internet or data connections.
 - Vertu shall not be liable for any delay in rendering service under the Limited Warranty, or loss of use during the period that the Product is being repaired.
 - Vertu's total liability in contract, tort (including negligence or breach of statutory duty), misrepresentation or otherwise, arising in connection with the sale of the Product shall be the price paid by the Client for the Product less a reasonable amount for usage.
 - The invalidity or unenforceability of any term or any part of any term of, or any right arising pursuant to, this Limited Warranty shall not affect the validity or enforceability of any other terms or rights or the remainder of any such term or right, which shall continue in full force and effect except for any such invalid or unenforceable provision or part thereof.
 - Vertu neither assumes nor authorises any authorised service centre or any other person or entity to assume for it any other obligation or liability beyond that which is expressly provided for in this Limited Warranty, including the provider or seller of any extended warranty or service agreement. Any change or amendment to this Limited Warranty requires Vertu's prior written consent.
 - This Limited Warranty represents the whole agreement between the parties relating to the subject matter hereof.
 - This Limited Warranty allocates the risk of failure of the Product between the Client and Vertu. The allocation is recognised by the Client and is reflected in the purchase price of the Product.
 - Any action or lawsuit for breach of warranty must be commenced within thirty (30) months following delivery of the Product.
 - All warranty information, product features and specifications are subject to change without notice.
 - Questions concerning this Limited Warranty may be directed to the Customer Service Department at the following addresses.
- Vertu operates a policy of continuous development. Vertu reserves the right to make changes and improvements to any of the products described in this document without prior notice.
- VERTU ONE-YEAR LIMITED INTERNATIONAL WARRANTY FOR ACCESSORIES
- THIS LIMITED WARRANTY SHALL NEITHER EXCLUDE NOR LIMIT (I) ANY MANDATORY STATUTORY RIGHTS OF THE OWNER OR (II) ANY OF THE OWNER'S RIGHTS AGAINST THE SELLER/DEALER OF THE PRODUCT.
- Vertu ("Vertu") warrants that this accessory product ("Product") is free from defects in material and workmanship, according to the following terms and conditions:

1. The Limited Warranty for the Product extends for ONE (1) year beginning on the date of original purchase or delivery of the Product whichever is the later. In case of a change of owner/user ("Owner"), such warranty period shall continue for the remaining part of the twelve (12) month period and otherwise remain unaffected.
2. During the period of the Limited Warranty, Vertu will repair, modify or replace, at Vertu's sole option, any defective parts, or any parts that will not properly operate for their intended use with new or refurbished replacement items if such repair or replacement is needed because of product malfunction or failure during normal usage. No charge will be made to the Owner for the repair or replacement of any such parts. Vertu will also pay for the labour charges incurred by Vertu in repairing or replacing the defective parts. The repaired Product will be warranted for the balance of the original warranty period or for ninety (90) days from the date of repair, whichever is longer. This Limited Warranty does not cover damage to or defects in (other than manufacturing defects) appearance, cosmetic, decorative or structural items and any non-operative parts. Vertu's limit of liability under the Limited Warranty shall be the price paid by the Owner for the Product when the Owner purchased the Product as a stand alone product or, in the event that the Owner received the Product when purchasing a Vertu cellular phone, the then current sale price for the Product, in both cases less a reasonable amount for usage. These remedies are the Owner's exclusive remedies for breach of this Limited Warranty.
3. Upon request from Vertu, the Owner must prove the date of the original purchase or delivery of the Product by producing a legible and non-modified original warranty card which clearly indicates the name and address of an authorised retailer, the date and place of purchase/delivery, the product type and the IMEI or serial number of the Product, a bill of sale or a dated receipt which contains the same information.
4. Vertu shall bear the cost of shipping the Product to the location from which the Owner handed over the Product to Vertu (or its representatives) after the completion of service under this Limited Warranty.
5. The Owner shall have no coverage or benefits under this Limited Warranty if any of the following conditions are applicable:
 - a) The Product has been subject to abnormal use, abnormal conditions, improper storage, spillage of liquid, misuse, neglect, exposure to cleaning agents not recommended, or other acts which are not the fault of Vertu, unauthorised repair, accident, alteration or other acts which are not the fault of Vertu.
 - b) The Customer Service Department at Vertu was not advised by the Owner in writing of the alleged defect or malfunction of the Product within thirty (30) days after the expiration of the applicable warranty period; or
 - c) The Product was not returned to Vertu or its authorised retailer within thirty (30) days after the appearance of the defect within the warranty period.
 - d) The defect or damage was as a result of general wear and tear incurred in normal usage of the Product.
6. If a problem develops during the period of the Limited Warranty, the following procedure will apply:
 - a) The Owner shall return the Product to the place of purchase for repair or replacement processing or if this is not convenient because of distance (more than 50 miles/80 km) or for other good cause, the Owner may contact the Customer Service Department at Vertu for further instructions.
 - b) The Owner shall bear the costs of transporting the Product to the relevant Vertu service location, with transport and insurance charges prepaid.
 - c) Subject to clause 6(e), the Owner will be billed for any parts or labour charges not covered by this Limited Warranty.
 - d) Vertu will repair or authorise the repair of the Product under the Limited Warranty within 30 days of receipt of the Product by Vertu or a Vertu authorised service centre, or within an extended period as may be notified by Vertu to Owner due to the nature of the repair ("Timeframe"). If Vertu cannot repair within the Timeframe, or after a reasonable number of attempts to repair the same defect, Vertu at its sole option, will provide a replacement Product or refund the purchase price of the Product less a reasonable amount for usage.
 - e) If the Product is returned to the Customer Service Department at Vertu during the period of the Limited Warranty, but the problem with the Product is not covered under the terms and conditions of this Limited Warranty, the Owner will be notified and given an estimate of the charges the Owner must pay to have the Product repaired, with all shipping charges billed to the Owner. If the estimate is refused, the Product will be returned freight collect. If the Product is returned to the Customer Service Department at Vertu after the expiration of the warranty period, Vertu's normal service policies shall apply and the Owner will be responsible for all shipping charges.
7. TO THE FULLEST EXTENT PERMITTED BY LAW, THE WARRANTIES AND CONDITIONS STATED IN THIS LIMITED WARRANTY ARE IN LIEU OF ALL OTHER CONDITIONS, WARRANTIES OR OTHER TERMS CONCERNING THE SUPPLY OR PURPORTED SUPPLY OF, OR FAILURE TO SUPPLY OR DELAY IN SUPPLYING THE PRODUCT WHICH MIGHT, BUT FOR THE AFFECT OF THIS CLAUSE 7, HAVE EFFECT BETWEEN VERTU AND THE OWNER OR WOULD OTHERWISE BE IMPLIED OR INCORPORATED INTO THIS LIMITED WARRANTY OR ANY COLLATERAL CONTRACT, WHETHER BY STATUTE, COMMON LAW OR OTHERWISE, ALL OF WHICH ARE HEREBY EXCLUDED (INCLUDING WITHOUT LIMITATION, THE IMPLIED CONDITIONS, WARRANTIES OR OTHER TERMS AS TO SATISFACTORY QUALITY OR FITNESS FOR PURPOSE).

8. VERTU SHALL NOT BE LIABLE FOR LOSS OR DAMAGE, WHETHER SPECIAL, INDIRECT, INCIDENTAL OR CONSEQUENTIAL, INCLUDING BUT NOT LIMITED TO ANY OF THE FOLLOWING LOSSES OR DAMAGE (WHETHER SUCH LOSSES OR DAMAGE WERE FORESEEN, FORESEEABLE, KNOWN OR OTHERWISE):
- a) LOSS OF ANTICIPATED BENEFITS OR PROFITS
 - b) LOSS OF ACTUAL OR ANTICIPATED SAVINGS
 - c) PUNITIVE, SPECIAL OR CONSEQUENTIAL DAMAGES.
 - d) THIRD PARTY CLAIMS
 - e) LOSS OF USE OF THE PRODUCT OR ANY ASSOCIATED EQUIPMENT OR FACILITIES
 - f) DOWNTIME OR LOSS OF BUSINESS
 - g) LOSS OF OPPORTUNITY
 - h) LOSS OF GOODWILL
 - i) LOSS OF REPUTATION
9. Vertu shall not be liable for any delay in rendering service under the Limited Warranty, or loss of use during the period that the Product is being repaired.
10. Vertu's total liability in contract, tort (including negligence or breach of statutory duty), misrepresentation or otherwise, arising in connection with the sale of the Product shall be the price paid by the Owner for the Product less a reasonable amount for usage.
11. The invalidity or unenforceability of any term or any part of any term of, or any right arising pursuant to, this Limited Warranty shall not affect the validity or enforceability of any other terms or rights or the remainder of any such term or right, which shall continue in full force and effect except for any such invalid or unenforceable provision or part thereof.
12. Vertu neither assumes nor authorises any authorised service centre or any other person or entity to assume for it any other obligation or liability beyond that which is expressly provided for in this Limited Warranty including the provider or seller of any extended warranty or service agreement. Any change or amendment to this Limited Warranty requires Vertu's prior written consent.
13. This Limited Warranty represents the whole agreement between the parties relating to the subject matter hereof.
14. This Limited Warranty allocates the risk of failure of the Product between the Owner and Vertu. The allocation is recognised by the Owner and is reflected in the purchase price of the Product.
15. Any action or lawsuit for breach of warranty must be commenced within eighteen (18) months following delivery of the Product.
16. All warranty information, product features and specifications are subject to change without notice.
17. Questions concerning this Limited Warranty may be directed to the Customer Service Department at the following addresses.

Vertu operates a policy of continuous development. Vertu reserves the right to make

changes and improvements to any of the products described in this document without prior notice.

VERTU REGIONAL OFFICES

If contacting us from Europe, Middle East and Africa:

VERTU LTD
BEACON HILL ROAD
CHURCH CROOKHAM
HAMPSHIRE
GU52 8DY
UNITED KINGDOM

If contacting us from the Americas:

CALL: 1-866-823-6843

If contacting us from Asia Pacific:

VERTU PTE LTD
391B ORCHARD ROAD
#24-02/05, Ngee Ann City, Tower B
SINGAPORE 238874

SAR NOTICE – RHV-2

YOUR VERTU PHONE (MODEL: SIGNATURE, TYPE: RHV-2, FCC ID: P7QRHV-2) MEETS GUIDELINES FOR EXPOSURE TO RADIO WAVES

Your Vertu phone is a radio transmitter and receiver. It is designed and manufactured not to exceed the limits for exposure to radio frequency (RF) energy recommended by international guidelines (ICNIRP). These limits establish permitted levels of RF energy for the general population. The guidelines are based on standards that were developed by independent scientific organizations through periodic and thorough evaluation of scientific studies. The standards and guidelines include a substantial safety margin designed to assure the safety of the public, regardless of age and health and to account for any variations in measurements.

The exposure guidelines for mobile devices employ a unit of measurement known as the Specific Absorption Rate or SAR. The SAR limit stated in the international guidelines is 2.0 watts/kilogram (W/kg) averaged over ten grams of tissue. Tests for SAR are conducted using standard operating positions with the phone transmitting at its highest certified power level in all tested frequency bands. The actual SAR level of an operating phone can be well below the maximum value because the phone is designed to use only the power required to reach the network. That amount changes depending on a number of factors such as how close you are to a network base station. The highest SAR value when tested according to international testing procedures for use at the ear is 0.65 W/kg.

This phone meets RF exposure guidelines when used either in the normal use position against the ear or when worn on the body using the Vertu approved belt holster (type BH3-BL01) designated for this phone model.

If you do not use the Vertu belt holster type BH3-BL01 for body worn operation, the phone should be positioned at least 7/8 inch (2.2 cm) away from the body. If an alternative holder (carry case, belt clip, holster, etc.) is used for body-worn operation, it should not contain metal and should position the phone the above-stated distance from your body.

In order to transmit data files or messages, this phone model requires a good quality connection to the network. In some cases, transmission of data files or messages may be delayed until such a connection is available. Ensure the above-stated instructions for body worn operation are followed until the transmission is completed.

SAR values may vary depending on national reporting and testing requirements and the network band. Use of phone accessories and enhancements may result in different SAR values. Additional SAR information may be provided under product information at www.vertu.com.

USA and Canada: The SAR limit of USA (FCC) and Canada (IC) is 1.6 W/kg averaged over one gram of tissue. This phone model has also been tested against this SAR limit. The highest SAR value reported under this standard during product certification for use at the ear is $?.??$ W/kg and when properly worn on the body is $?.??$ W/kg. Information about this phone model can be found on the FCC's website at <http://www.fcc.gov/oet/fccid> by searching the equipment authorization system using FCC ID: IC:4299A-RHV2.

NOTICE

Copyright © Vertu Limited 2005. All rights reserved.

Reproduction, transfer, distribution or storage of part or all of the contents in this document in any form without the prior written permission of Vertu is prohibited. Vertu operates a policy of continuous development. Vertu reserves the right to make changes and improvements to any of the products described in this document without prior notice.

Under no circumstances shall Vertu be responsible for any loss of data or income or any special, incidental, consequential or indirect damages howsoever caused.

The contents of this document are provided "as is". Except as required by applicable law, no warranties of any kind, either expressed or implied, including, but not limited to, the implied warranties of merchantability and fitness for a particular purpose, are made in relation to the accuracy, reliability or contents of this document. Vertu reserves the right to revise this document or withdraw it at any time without prior notice. The availability of particular products may vary by region. Please check with Vertu Concierge.

Vertu and the Vertu logo are registered trademarks of Vertu Limited. Vertu's product names are either trademarks or registered trademarks of Vertu Limited. Other product and company names mentioned herein may be trademarks or tradenames of their respective owners.

US Patent No 5818437 and other pending patents. T9 text input software copyright © 1997-2002. Tegic Communications, Inc. All rights reserved.

Includes RSA BSAFE cryptographic or security protocol software from RSA Security.

EXPORT CONTROLS

Your Vertu phone may contain commodities, technology, or software exported from the United States in accordance with the Export Administration regulations. Diversion contrary to U.S. law is prohibited.

FCC/INDUSTRY CANADA NOTICE

Your Vertu phone may cause TV or radio interference (for example, when using a telephone in close proximity to receiving equipment). The FCC or Industry Canada can require you to stop using your phone if such interference cannot be eliminated. If you require assistance, contact Vertu Concierge. This device complies with Part 15 of the FCC rules. Operation is subject to the following two conditions: (1) this device may not cause harmful interference, and (2) this device must accept any interference received, including interference that may cause undesired operation.

Note: Vertu is not responsible for any radio or TV interference caused by unauthorized modifications to this equipment. Such modifications could void your authority to operate the equipment.

DECLARATION OF CONFORMITY

We, Vertu Limited declare under our sole responsibility that the product, Model Signature, type **RHV-2** is in conformity with the provision of the following Council Directive:
1999/5/EC.

A copy of the Declaration of Conformity can be found at <http://www.vertu.com>

CE168

EU RECYCLING NOTICE

Vertu will comply with European Community requirements for the recycling of Waste Electrical & Electronic Equipment (WEEE).

This compliance is indicated by the addition of the following symbol to Vertu's products where appropriate.



The symbol indicates that the product was put onto the market after the WEEE legislation was implemented and that the consumer should not dispose of the item in normal household waste, but that it should be appropriately recycled.

Should you wish Vertu to recycle your product at the end of its life, please either return it to the point from which you purchased your product (if known) or return it to Vertu's headquarters.

Alternatively, should you purchase a replacement product from another supplier, the new supplier is obligated to take back the product that is being replaced and recycle it appropriately.

Background information on the European WEEE directive is available from www.europa.eu.int/