

# Operating instructions

for the system user

**VIESSMANN**

**Vitoconnect**  
**Type OPTO2**  
**Type OT2**

Communications interface for remote monitoring and remote control of heating systems over the Internet, for the following user interfaces:

- ViCare app
- Vitoguide

## VITOCONNECT





## Safety instructions

### Safety instructions

 Please follow these safety instructions closely to prevent accidents and material losses.

#### Safety instructions explained

 **Danger**  
This symbol warns against the risk of injury.

 **Please note**  
This symbol warns against the risk of material losses and environmental pollution.

**Note**  
*Details identified by the word "Note" contain additional information.*

#### Target group

These instructions are intended for the persons operating the system.

Individual sections of this manual describe activities that are to be executed by qualified contractors. This appliance can also be operated by children aged 8 years and older, as well as by individuals with reduced physical, sensory or mental faculties or those lacking in experience and knowledge, provided that such individuals are being supervised or have been instructed in the safe use of this appliance and understand the dangers arising from it.

 **Danger**  
The operation of electronic medical aids in particular, e.g. heart pacemakers, hearing aids and defibrillators can get disrupted by radio signals. If such devices are used, direct proximity to operationally ready wireless components must be avoided.

#### Installing and settings

- Make settings and carry out work on the appliance only in accordance with the instructions in this manual.
- Work on electrical equipment may only be carried out by a qualified electrician.
- Connect the appliances only to properly installed sockets.
- When working on the appliance, pull the mains plug.
- Comply with the minimum distances in order to ensure reliable signal transmission.

#### System operation

- Operate the appliances in dry internal areas only (not in bathrooms).
- Do not operate the appliances in areas with a potentially explosive atmosphere.
- Protect the devices from:
  - Wetness
  - Dust
  - Liquids
  - Vapours
  - Direct sunlight
  - Any other direct thermal radiation
- After a power failure or a restart, check the status of the wireless components.
- Do not touch the power supply with wet hands.

 **Danger**  
Damaged appliances endanger your safety. Check the appliance for external damage. Do not switch on a damaged appliance.

#### Auxiliary components and individual parts

For replacements, use original Viessmann parts only or individual parts approved by Viessmann.

 **Danger**  
There is a danger of fire from connecting unsuitable power supplies. Connect only the supplied power supply unit.

## Index

<b>1. Safety and liability</b>	Operational safety .....	5
	Liability .....	5
<b>2. Information before starting</b>	Symbols .....	6
	Qualified contractor .....	6
	Intended use .....	6
	Product information .....	7
	■ Data connections with Vitoconnect, type OPTO2 .....	7
	■ Data connections with Vitoconnect, type OT2 .....	7
	Operation via app .....	8
	■ ViCare app operating functions .....	8
	■  Vitoguide operating functions .....	8
	■ Forwarding messages .....	9
<b>3. Preparing for installation</b>	System requirements .....	10
	■ Supported control units .....	10
	■ IP network .....	10
	Installation site .....	10
	■ Vitoconnect .....	10
	■ Vitotrol 100, type OT1 .....	10
	■ Ranges .....	11
<b>4. Installation sequence</b>	Overview of steps for installation and commissioning .....	12
	Installing the wall bracket .....	13
	■ Vitoconnect .....	13
	■ Vitotrol 100, type OT1 .....	14
	Vitoconnect, connect type OPTO2 to heat generator .....	14
	Connecting Vitoconnect, type OT2 .....	15
	■ Vitoconnect, connecting type OT2 to the heat generator .....	15
	■ Vitoconnect, connecting type OT2 to Vitotrol 100 .....	16
	Closing the device and inserting it into the wall bracket .....	16
	■ Vitoconnect .....	16
	■ Vitotrol 100, type OT1 .....	17
	Vitoconnect mains connection .....	17
<b>5. Commissioning</b>	Display and operating elements .....	18
	■ Meaning of the LEDs .....	19
	Checking the network settings .....	19
	Registering users and setting up the heating system .....	20
	■ Android operating system: Setting up Wi-Fi .....	20
	■ iOS operating system: Setting up Wi-Fi .....	20
<b>6. Operating functions</b>	Access point mode .....	21
	■ Activating access point mode .....	21
	■ Deactivating access point mode .....	21
	Temporarily adjusting the room temperature .....	21
<b>7. What to do?</b>	Measures for troubleshooting .....	22
	Restarting the Vitoconnect .....	22
	Restoring delivered condition .....	23
	Maintenance mode .....	23
	■ Activating maintenance mode .....	23
	■ Deactivating maintenance mode .....	23
	Setting up Wi-Fi after replacing the router .....	23
<b>8. Parts lists</b>	Ordering parts .....	25
	Parts list Vitoconnect, type OPTO2 .....	26
	Parts list Vitoconnect, type OT2 .....	28
<b>9. Specification</b>	.....	30

<b>10. Keyword index</b>	.....	<b>31</b>
--------------------------	-------	-----------

## Operational safety

Vitoconnect facilitates communication over the Internet between the following components and the Viessmann server:

- Vitotronic control unit (Optolink interface)
- Heat generator with OpenTherm interface

The full range of functions is only available if the following conditions are fulfilled:

- The Vitotronic control units, the heat generator with OpenTherm interface **and** the Vitoconnect must be correctly connected and configured.
- The Vitoconnect is connected to the Internet via a Wi-Fi router.
- Internet access must be available at all times.

- The user registration has been carried out: see page 20.
- For messages to be sent even in case of a power failure, we recommend an uninterruptible power supply for the Vitoconnect and the Wi-Fi router.

### Note









- *The heating system and the operability of the message channels must be checked at regular intervals.*
- *To further enhance the operational safety of the heating system, we recommend planning supplementary measures, such as frost protection or checking for water damage.*

## Liability

No liability is accepted for lost profit, missed savings, or other direct or indirect consequential damage that arises from the use of Vitoconnect, the Viessmann server or the software, as well as for damage from incorrect use. The limitation of liability is not applicable if the damage is caused wilfully or by gross negligence, or if there is an obligatory liability according to the product liability law.

The General Terms and Conditions of Sale contained in the respective latest Viessmann price list apply. Push messaging and email services are services from network operators, for which Viessmann is not liable. In these cases the T&Cs of the respective network operators apply.

## Symbols

Symbol	Meaning
	Reference to other document containing further information
	Step in a diagram: The numbers correspond to the order in which the steps are carried out.
	Warning of material losses and environmental pollution
	Live electrical area
	Pay particular attention.
	<ul style="list-style-type: none"> <li>▪ Component must audibly click into place. or</li> <li>▪ Acoustic signal</li> </ul>
	<ul style="list-style-type: none"> <li>▪ Fit new component. or</li> <li>▪ In conjunction with a tool: Clean the surface.</li> </ul>
	Dispose of component correctly.
	Dispose of component at a suitable collection point. Do <b>not</b> dispose of component in domestic waste.

## Qualified contractor



Activities that may only be carried out by a qualified contractor are marked with this icon.

Work on electrical equipment may only be carried out by a qualified electrician.

## Intended use

In keeping with the intended use, Vitoconnect products should be installed and operated exclusively in conjunction with the electronic control units and controllers of the Viessmann heat and power generators supported for this purpose.

Vitoconnect products are designed for operation in buildings used for residential and business purposes only. Misuse of the appliances is prohibited and will result in exclusion of liability (e.g. commercial or industrial use for a purpose other than for control and regulation).

Compliance is required with the installation, service and operating instructions supplied with the product and provided online.

Vitoconnect products are to be used exclusively for monitoring, operation and optimisation of the systems, using the user and communications interfaces defined in the printed material of the product. For the communications interfaces, it must be ensured on-site that for all the transmission media used, the system requirements defined in the product documents are met at all times (e.g. the required Wi-Fi connection to a Wi-Fi router).

**Intended use** (cont.)

For voltage supply, only the components specified for this purpose may be used (e.g. wall power supplies).

**Note**

*The appliances are designed exclusively for domestic or domestic-like use, i.e. even uninstructed persons can safely operate them.*

**Product information**

Vitoconnect is a wall-mounted Internet interface that communicates with the boiler control unit of the heat generators.

- Using an Optolink interface, the Vitoconnect type OPTO2 can be used for single-boiler systems without any downstream heating circuits.
- Using an OpenTherm interface, the Vitoconnect type OT2 can be used for single-boiler systems without any downstream heating circuits.

The Vitoconnect enables remote operation of heating systems over the Internet. For settings and queries the ViCare app is used. A qualified contractor can alternatively control the heating system via Vitoguide.

**Data connections with Vitoconnect, type OPTO2**

In conjunction with heat generators with Optolink interface only

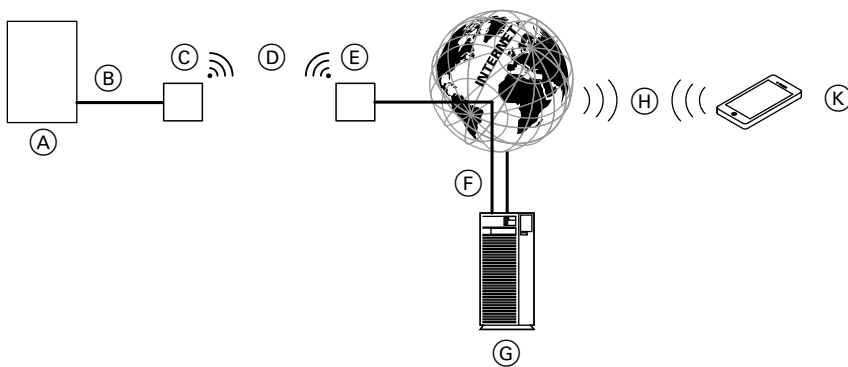

Fig. 1

- |  |                      |
|--|----------------------|
| (A) Heat generator with control unit                   | (G) Viessmann server |
| (B) Optolink connecting cable                          | (H) Mobile network   |
| (C) Vitoconnect, type OPTO2                            | <b>or</b>            |
| (D) Wi-Fi  | Wi-Fi connection     |
| (E) Wi-Fi router (on site)                             | (K) Smartphone       |
| (F) Secure Internet connection to the Viessmann server |                      |

**Data connections with Vitoconnect, type OT2**

In conjunction with heat generators with OpenTherm interface only

**Product information** (cont.)

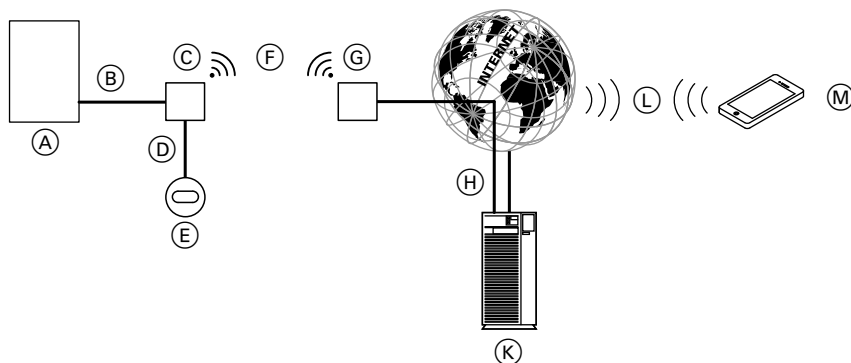

Fig. 2

- (A) Heat generator with control unit
- (B) OpenTherm connecting cable
- (C) Vitoconnect, type OT2
- (D) OpenTherm connecting cable
- (E) Vitotrol 100, type OT1
- (F) Wi-Fi
- (G) Wi-Fi router (at the site)
- (H) Secure Internet connection to the Viessmann server
- (K) Viessmann server
- (L) Mobile network
- or
- Wi-Fi connection
- (M) Smartphone

**Operation via app**

For remote operation of Viessmann heat generators with Optolink interface or OpenTherm interface over IP networks.

**ViCare app operating functions**

- Query the temperatures of the connected heating circuits.
- Adjust the temperatures and time programs for the central heating and DHW heating.
- Adjust the heating times by means of a **"heating times wizard"**.
- Set the comfort and reduced operation using quick selection buttons ("**I am at home for longer**" and "**I am travelling**").
- Add more users for operating the heating system.
- Save the contact data of your contractor to get in touch more easily.
- Assign service access to the contractor to have system data such as error messages transmitted to the contractor.
- View heating system error messages in plain text by means of push messaging.

**Note**  
 For further information on the ViCare app see [www.vicare.info](http://www.vicare.info)  
 or  
 App Store and Google Play

**Vitoguide operating functions**

- Monitoring of the heating system once the system operator has assigned service access
- Querying the system information of the connected heating system
- Specification for operating programs, set values and time programs
- Viewing fault messages in plain text
- Automatic forwarding of fault messages by email



**Operation via app** (cont.)**Forwarding messages**

Messages that are queued at the heating system, such as sensor or burner faults, are transmitted to the Vitoconnect over the OpenTherm or Optolink connecting cable. Vitoconnect transmits these messages to the Viessmann server. The ViCare app polls the status of the heating system cyclically and displays the messages.

**Note**

*Messages of the heating system are only displayed if the ViCare app is active on the mobile end device.*

**Content of the messages**

- Message type
- Message code
- Message text



Heat generator installation and service instructions

## System requirements

### Supported control units

Current overview of the supported control units: see [www.viessmann.com/vitocconnect](http://www.viessmann.com/vitocconnect)

### IP network

#### System requirements

- Wi-Fi router with activated Wi-Fi. The Wi-Fi router must be protected by a sufficiently secure WPA2 password. Unencrypted connections of the Vitoconnect to the Wi-Fi router are discouraged.
- Internet connection with "flatrate" (fixed charge with **unlimited** time and data) with high availability, i.e. the Vitoconnect is permanently connected to the Viessmann server.
- Network (Wi-Fi) with dynamic IP addressing (DHCP, delivered condition); have an IT professional check this **before** commissioning; set up if required.
- Define the routing and security parameters for the IP network (LAN): open port 80, port 123, port 443 and port 8883 for directly outgoing connections. Have an IT professional check this on-site **before** commissioning; set up if required.

#### Note

*During operation, Vitoconnect sets up a secure Internet connection to the Viessmann server. Connections of the Vitoconnect with other servers are not possible.*

#### User account

Regardless of the operating unit, the Vitoconnect requires a valid user account for the Viessmann server. This account is registered automatically at the time of commissioning via the ViCare app: see page 20).

#### Operating unit for ViCare app

The ViCare app supports the following end devices:

- End devices with Apple iOS operating system
- End devices with Google Android operating system

#### Note

- *Compatible versions: See the App Store or Google Play*
- *For further information see [www.vicare.info](http://www.vicare.info)*

#### Message destinations

End device for receiving email, for example computer, smartphone or tablet PC.

## Installation site

### Vitoconnect

#### Type of installation: Wall mounting

- Installation inside a closed building only
- The installation site must be dry and frost-free.
- Ambient temperatures between +5 and +40 °C must be ensured.
- Distance from the heat generator min. 0.3 m and max. 2.5 m
- 230 V/50 Hz Schuko socket  
or  
US/CA: 120 V/60 Hz outlet  
max. 1.5 m from the installation site
- Internet access with an adequate Wi-Fi signal

#### Note

*The Wi-Fi signal can be strengthened with a commercially available Wi-Fi repeater.*

#### Note

- *Observe the lengths of the supplied connecting cables when selecting the installation site.*
- *Keep the distance between the Vitoconnect and the Wi-Fi router as small as possible to ensure a good Wi-Fi connection.*

Connecting cables	Length
Wall power supply with connecting cable	1.5 m
Optolink or OpenTherm connecting cable to connect the Vitoconnect to the boiler control unit	3 m

### Vitotrol 100, type OT1

#### Type of installation: Wall mounting

- On an inner wall in the main living room, approx. 1.5 m from the floor
- The installation site must be dry and frost-free.

- Ensure ambient temperatures between 0 and +40 °C.
- Not in the immediate vicinity of doors and windows

**Installation site** (cont.)

- Not above radiators
- Not in cupboards, niches etc.
- Not near heat sources (direct sunlight, chimney, TV etc.)

**Ranges**

The range of Wi-Fi connections can be reduced by walls, ceilings and furniture. The strength of the Wi-Fi signal gets reduced and reception can be disturbed.

**Range reduction:**

- Wi-Fi signals get **attenuated** on the way from the transmitter to the receiver, for example, through the air and when penetrating walls.
- Wi-Fi signals are **reflected** by metallic parts, for example, reinforcement in walls, metal foils of heat insulation and metallised thermo-glass for heat insulation.
- Wi-Fi signals are **cut off** by supply blocks and lift shafts.
- Wi-Fi signals are **disturbed** by devices that also work with high-frequency signals. Keep a distance of **min. 2 m** to the following devices:
  - Computers
  - Audio and video systems
  - Radio signals
  - Electronic transformers
  - Ballast

**Note**

*We recommend keeping the distance between the Vitoconnect and the Wi-Fi router as small as possible to ensure a good Wi-Fi connection.*

**Overview of steps for installation and commissioning**

Work steps		Responsible party	Page	
			Type OPTO2	Type OT2
<b>Installation</b>				
1	Check the system requirements.	Heating contractor IT professional	10	10
2	Install the wall bracket for the Vitoconnect.	Heating contractor System operator	13	13
3	Install the wall bracket of the Vitotrol 100.	Heating contractor System operator	—	14
4	Connect the Vitoconnect to the heat generator.	Heating contractor	—	15
		Heating contractor System operator	14	—
5	Connect the Vitoconnect and the Vitotrol 100.	Heating contractor System operator	—	16
6	Insert the Vitoconnect in the wall bracket.	Heating contractor System operator	16	16
7	Insert the Vitotrol 100 in the wall bracket.	Heating contractor System operator	—	17
8	Set up the Vitoconnect mains connection.	Heating contractor System operator	17	17
<b>Commissioning</b>				
9	Check the network settings.	IT professional	19	19
10	Register the user and set up the heating system .	Heating contractor System operator	20	20

Installing the wall bracket

Vitoconnect

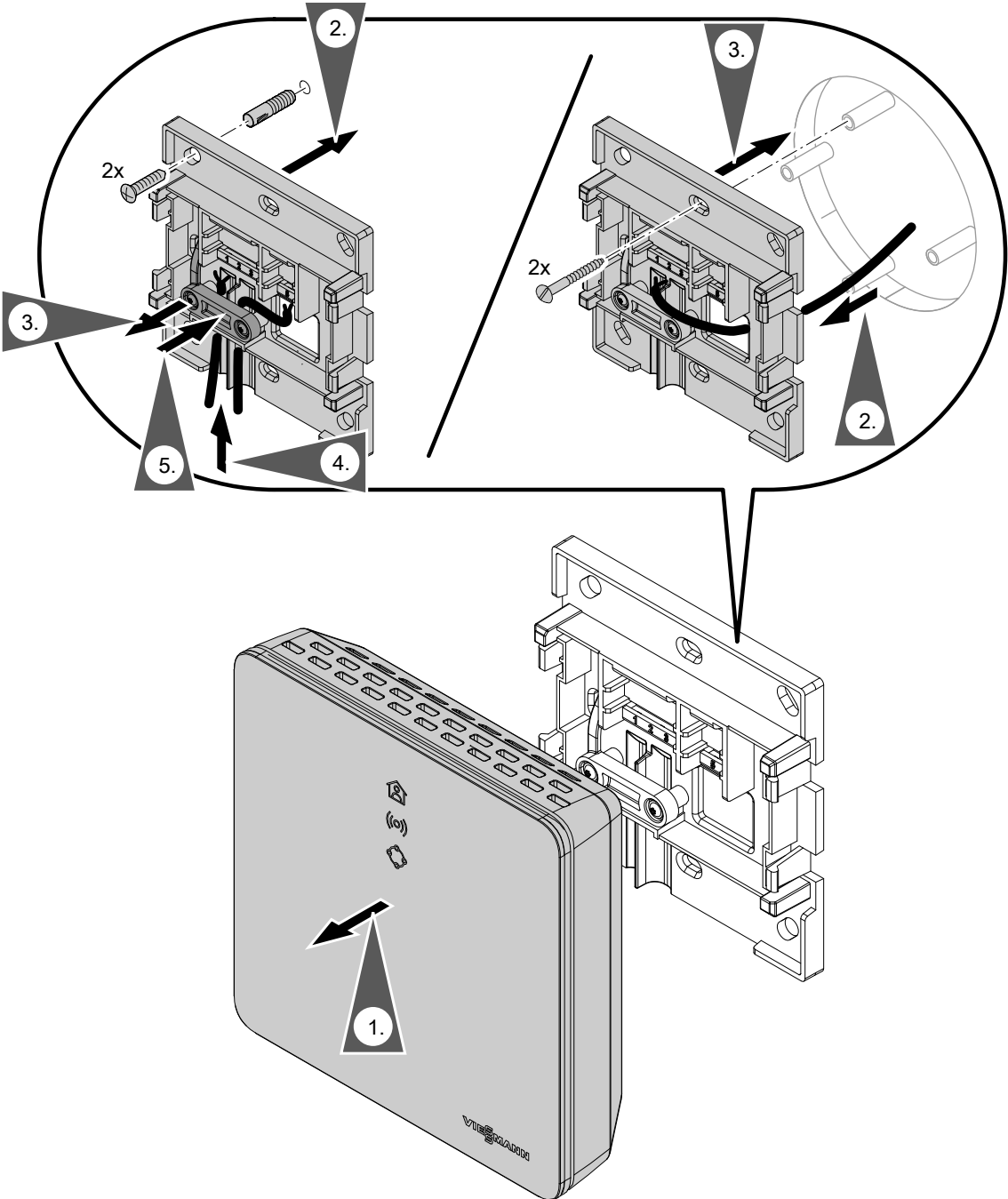

Installation

Fig. 3

## Installation sequence

### Installing the wall bracket (cont.)

#### Vitotrol 100, type OT1

In conjunction with Vitoconnect, type OT2 only

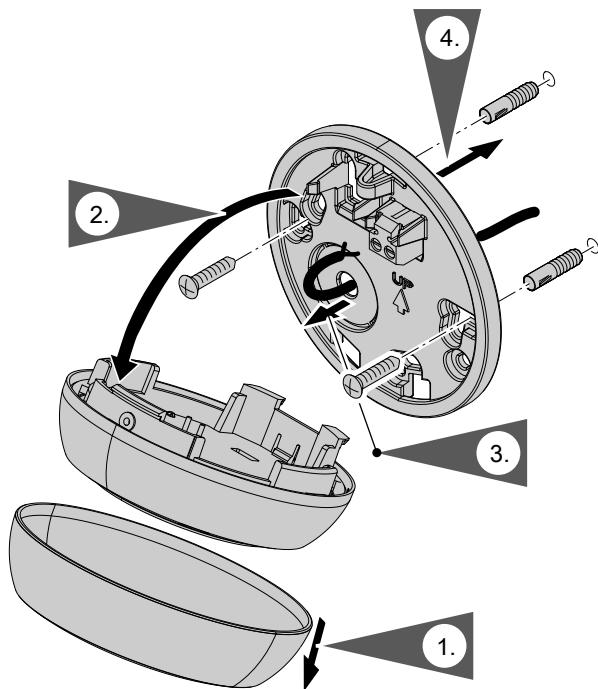

Fig. 4

### Vitoconnect, connect type OPTO2 to heat generator

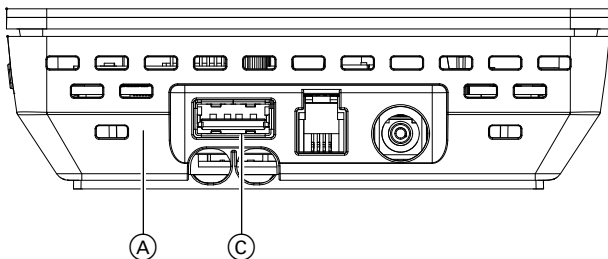

Fig. 5

- (A) Vitoconnect
- (C) USB connection

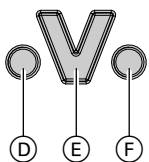

Fig. 6

- (D) Fault display
- (E) Optolink interface
- (F) Operation indicator

1. Insert the USB connector of the Optolink/USB connecting cable into the socket (C) of the Vitoconnect.

2. Connect the Optolink plug of the Optolink/USB connecting cable with the Optolink interface (E) at the control unit of the heat generator.





#### Connection to the heat generator

Operating instructions of the heat generator

Connecting Vitoconnect, type OT2

Vitoconnect, connecting type OT2 to the heat generator

1.  Connect the OpenTherm connecting cable to the heat generator.

 Heat generator installation and service instructions

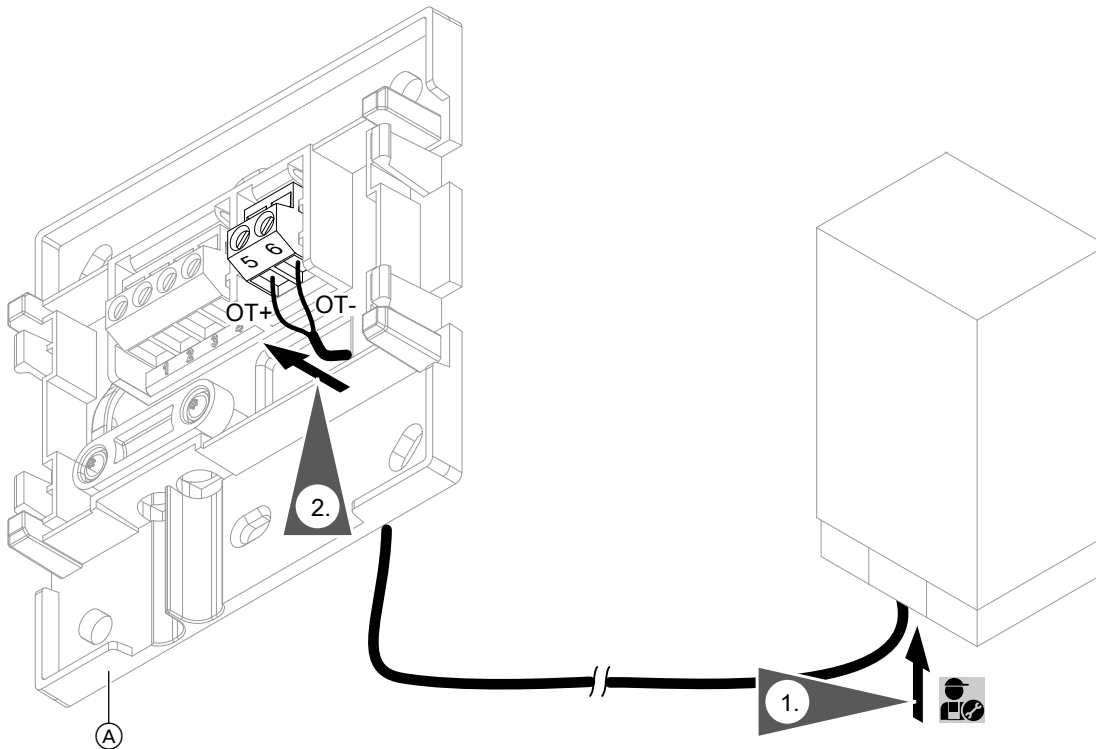

Fig. 7

Ⓐ Vitoconnect

## Installation sequence

### Connecting Vitoconnect, type OT2 (cont.)

#### Vitoconnect, connecting type OT2 to Vitotrol 100

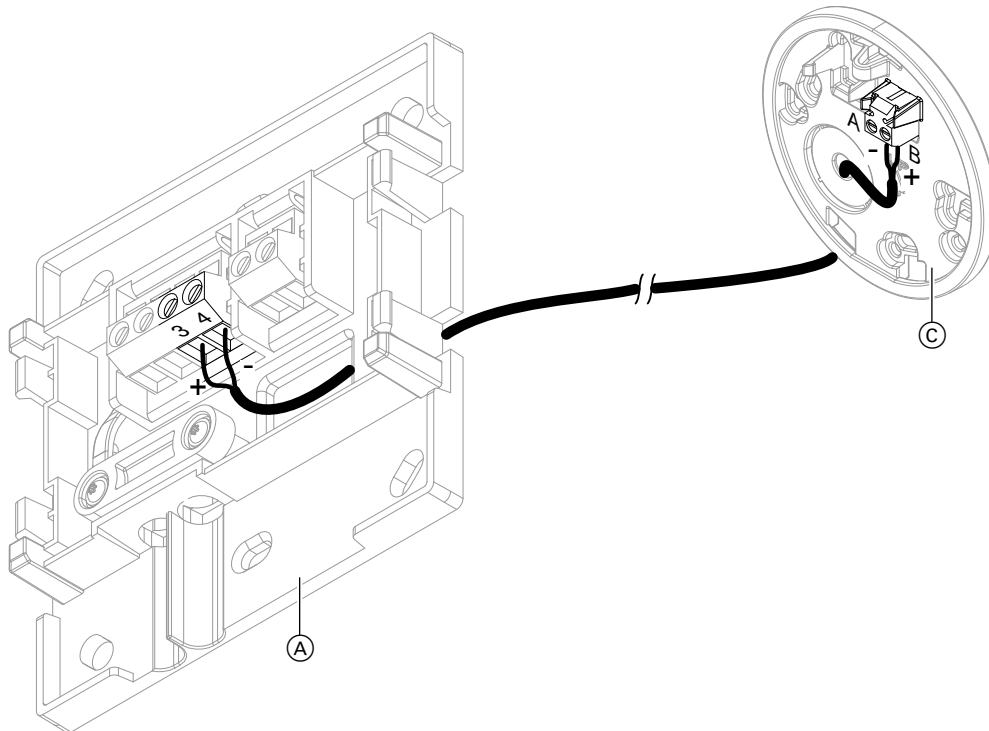

Fig. 8

- (A) Vitoconnect
- (C) Vitotrol 100, type OT1

### Closing the device and inserting it into the wall bracket

#### Vitoconnect

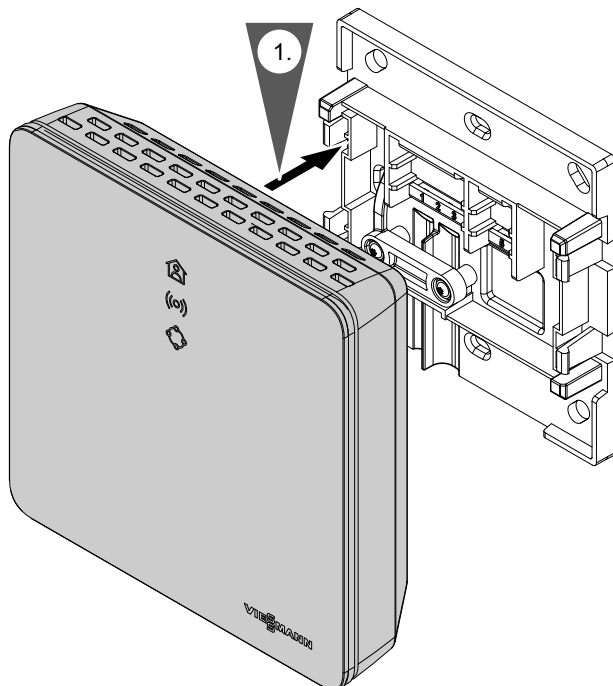

Fig. 9



## Closing the device and inserting it into the... (cont.)

### Vitotrol 100, type OT1

In conjunction with Vitoconnect, type OT2 only.

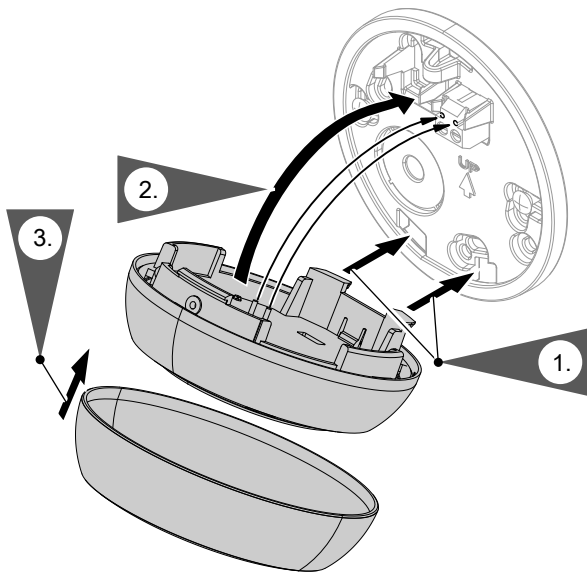

Fig. 10

### Vitoconnect mains connection

The socket for the wall power supply must be located in the vicinity of the appliance and be freely accessible.  
On-site fusing of the socket: max. 16 A (US, CA: max. 20 A).

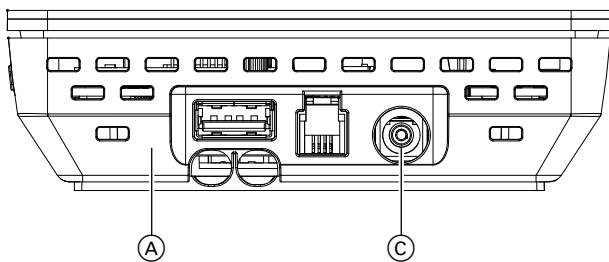

Fig. 11

- (A) Vitoconnect
- (C) Voltage supply connection

1. Insert the barrel connector of the wall power supply into the connection (C) of the Vitoconnect.
2. Insert the wall power supply for Vitoconnect into the socket.

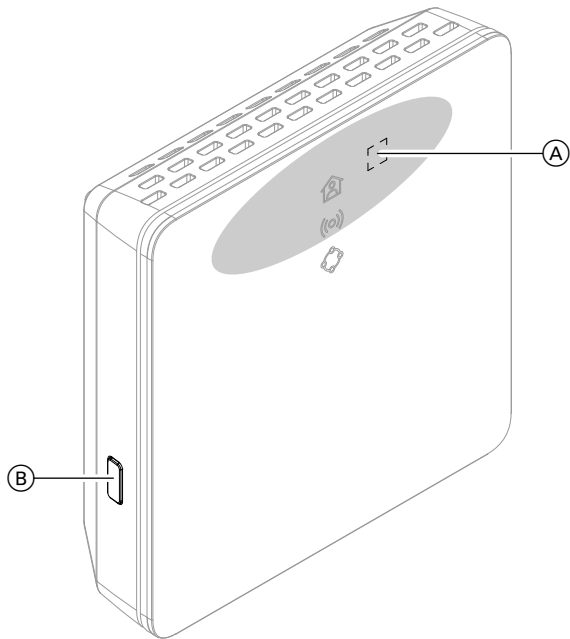





Fig. 12

- Ⓐ Operating button
- Ⓑ Reset button
- 🏠 LED indicates the state of the communication with the heat generator and the current operating status.
- 📶 LED indicates the state of the communication with the Wi-Fi and the Viessmann server.
- ⚙️ LED indicates the system functions (maintenance mode, restart, update, error).

■ = Actuation area of the operating button Ⓐ

## Display and operating elements (cont.)

### Meaning of the LEDs

LED  – communication with the heat generator and operating status	
Slowly pulsating in white.	Connection to Vitoconnect established successfully: Operation program " <b>I am at home for longer</b> " is active.
Illuminated in white.	Connection to Vitoconnect established successfully: Central heating according to time program
LED  – communication with the Viessmann server	
Illuminated in green.	Connection between Vitoconnect and Viessmann server established successfully: <ul style="list-style-type: none"> <li>▪ Access point mode is active.</li> <li>Or</li> <li>▪ Vitoconnect is starting.</li> </ul>
Pulsating in yellow.	Connection between Vitoconnect and Wi-Fi router failed: see page 22.
Illuminated in yellow.	No Internet connection: see page 22
Rapidly flashes red.	Firmware or hardware error: see page 22
Illuminated in red.	Connection between Vitoconnect and Viessmann server failed: see page 22
LED  – system functions	
Pulsating in green.	Connection between Vitoconnect and ViCare thermostat is being established
Illuminated in green.	<ul style="list-style-type: none"> <li>▪ Vitoconnect is starting.</li> <li>Or</li> <li>▪ A new Vitoconnect firmware is being installed.</li> </ul> <p><b>!</b> <b>Please note</b> Do not damage the Vitoconnect. During firmware installation, <b>do not</b> disconnect the Vitoconnect from the mains supply.</p>
Flashes yellow.	Communication error with the Vitotrol 100, type OT1: see page 22
Rapidly flashes yellow.	No connection to the heat generator: see page 22
Pulsating in red.	Maintenance mode (no data transmission): see page 23
Flashes red.	Vitoconnect has been reset to the delivered condition and can be commissioned once again.
Rapidly flashes red.	Firmware or hardware error: see page 22
Illuminated in red.	Error in the control unit of the heat generator: see page 22

#### Note

*Slowly pulsating:* The LED flashes once every 4 s bright and darker.

*Pulsating:* The LED flashes once every second bright and darker.

*Flashing:* The LED is on once every second.

*Rapid flashing:* The LED is on twice every second.

## Checking the network settings

Have the following settings on the Wi-Fi router checked and adjusted by an IT professional, if required:

- Dynamic IP addressing must be active.
- Port 80, port 123, port 443 and port 8883 must be open for outgoing connections.

### Registering users and setting up the heating system

1. Download the ViCare app from the App Store or Google Play and install it.  
**Note**  
*Apple iPad and Android tablet PCs are **not** supported.*
2. Start the ViCare app and tap "**Create account**".
3. Follow the instructions in the ViCare app.
4. Scan the QR code.  
Or  
Enter the numbers for "**S/N**" and "**ID**".

**Note**

*QR code, "S/N" and "ID": See the supplied Vitoconnect sticker.*

5. Set up the Vitoconnect Wi-Fi: see the next chapter.
6. Connect the Vitoconnect to your home network. The Vitoconnect and the ViCare app are set up when the LED  is illuminated in white: See chapter "Display and operating elements".

---

### Android operating system: Setting up Wi-Fi

Automatic connection with "**Vitoconnect<xxxx>**" Wi-Fi.

---

### iOS operating system: Setting up Wi-Fi

1. Open the Wi-Fi settings of your smartphone.
2. Connect your smartphone to the "**Vitoconnect<xxxx>**" Wi-Fi.
3. Insert the WPA2 password from the clipboard.

**Note**

*The WPA2 password can be found on the supplied sticker.*

**Note**

*The WPA2 password will automatically be in the clipboard.*

## Access point mode

Activate the access point mode, for example, after replacing the Wi-Fi router or to allow service queries from the contractor.

### Activating access point mode

Press the operating button **(A)** for longer than 5 s, but not longer than 30 s: See chapter "Display and operating elements".

LED **(●)** illuminated in green:

Access point mode is active.

### Deactivating access point mode

1. Access point mode is automatically deactivated after 5 min.

**Or**

2. Once again press the operating button **(A)** for longer than 5 s, but not longer than 30 s: See chapter "Display and operating elements".

LED **(●)** not illuminated any more.

Access point mode is deactivated.

## Temporarily adjusting the room temperature

If you wish to heat your premises to a higher temperature for a limited time, activate the **"I am at home for longer"** operating program.

**You have two options for setting the operating program:**

Press the operating button **(A)** for max. 3 s: See chapter "Display and operating elements".

**Or**

Set the operating program via the ViCare app.

## What to do?

### Measures for troubleshooting

Malfunctions at the Vitoconnect are shown by various LED indications: see page 18.

#### Malfunctions with LED indications

	Type of fault and measures
<b>LED (◐)</b>	
Pulsating in yellow.	<b>Connection between Vitoconnect and Wi-Fi router failed:</b> <ul style="list-style-type: none"> <li>Check the password at the time of Wi-Fi commissioning.</li> <li>Restart the Vitoconnect: see page 22.</li> </ul>
Illuminated in yellow. <b>Or</b> Illuminated in red.	<b>No Internet connection or No connection to the Viessmann server</b> <ul style="list-style-type: none"> <li>No Wi-Fi connection                             <ul style="list-style-type: none"> <li>Check the network setting at the time of Wi-Fi commissioning.</li> <li>Check the password at the time of Wi-Fi commissioning.</li> </ul> </li> <li>Inadequate Wi-Fi signal strength                             <ul style="list-style-type: none"> <li>Change the installation site of the Vitoconnect: see page 10</li> </ul> </li> <li>The Wi-Fi connection is active, but there is no Internet connection                             <ul style="list-style-type: none"> <li>Check the Internet connection with another device, e.g. a laptop. If an Internet connection cannot be established with other devices either, have your network settings checked by an IT professional.</li> </ul> </li> <li>Restart the Vitoconnect: see page 22.</li> </ul>
Rapidly flashes red.	<b>Firmware or hardware error</b> <ul style="list-style-type: none"> <li>Restart the Vitoconnect: see 22.</li> <li>Replace the Vitoconnect, if required.</li> </ul>
<b>LED (◑)</b>	
Flashes yellow.	<b>Communication error with the Vitotrol 100, type OT1:</b> <ul style="list-style-type: none"> <li>Check the OpenTherm connecting cable to the Vitotrol 100, type OT1: see page 16</li> <li>Restart the Vitoconnect: see page 22</li> </ul>
Rapidly flashes yellow.	<b>No connection to the heat generator</b> <ul style="list-style-type: none"> <li>Check the plug-and-socket connections (Optolink, USB).</li> <li>Check the connecting cable.</li> <li>Restart the Vitoconnect: see page 22.</li> </ul>
Pulsating in red.	<b>Maintenance mode (no data transmission)</b> <ul style="list-style-type: none"> <li>Deactivate the maintenance mode: see page 23</li> </ul>
Rapidly flashes red.	<b>Firmware or hardware error</b> <ul style="list-style-type: none"> <li>Restart the Vitoconnect: see page 22</li> <li>Replace the Vitoconnect, if required.</li> </ul>
Illuminated in red.	<b>Error in the control unit of the heat generator</b> <ul style="list-style-type: none"> <li>Observe the message in the ViCare app.</li> <li>                      Heat generator installation and service instructions                 </li> </ul>

#### Malfunctions without LED indications

Fault	Measures
All Vitoconnect LEDs are off.	Check the mains connection and wall power supply of the Vitoconnect.

### Restarting the Vitoconnect



After rectifying the fault, the Vitoconnect has to be restarted.

## Restarting the Vitoconnect (cont.)

Press the Reset button (B) and the operating button (A) for approx. 15 s: See chapter "Display and operating elements".

LED  illuminated in white.

## Restoring delivered condition

1. Press the Reset button (B) for approx. 30 s: see page 18.  
LED  flashes red.
2. Press the Reset button (B) once again within 5 s.  
LED  not illuminated any more.  
The Vitoconnect is restarting and resumes the delivered condition.

## Maintenance mode

This function suppresses the transmission of messages from the heating system to the Viessmann server, e.g. during maintenance work on the heating system.

### Activating maintenance mode

Press the Reset button (B) for approx. 5 s to 15 s: see page 18

LED  pulsating in red.

Maintenance mode is activated.

#### Note

*The maintenance mode does not stop automatically but has to be deactivated.*

### Deactivating maintenance mode

Press the Reset button (B) once again for approx. 5 s to 15 s: see page 18

LED  not illuminated any more.

Maintenance mode is deactivated.

## Setting up Wi-Fi after replacing the router

1. Activate the Vitoconnect access point mode: see page 21
2. Open the Wi-Fi settings of your smartphone.
3. Connect your smartphone to the "Vitoconnect<xxxx>" Wi-Fi.
4. Enter the WPA2 password.
5. Use the Internet browser on your smartphone to access <http://vitoconnect.gateway>
6. On the starting page, select "Select router".
7. Follow the instructions on the Internet page.
8. Deactivate the Vitoconnect access point mode: see page 21

#### Note

*The WPA2 password can be found on the supplied sticker.*

What to do?

## Setting up Wi-Fi after replacing the router (cont.)



## Ordering parts

The following details are required when ordering parts:

- Order no. (see type plate (A))
- Item number of the individual part (from this parts list)

Parts list Vitoconnect, type OPTO2

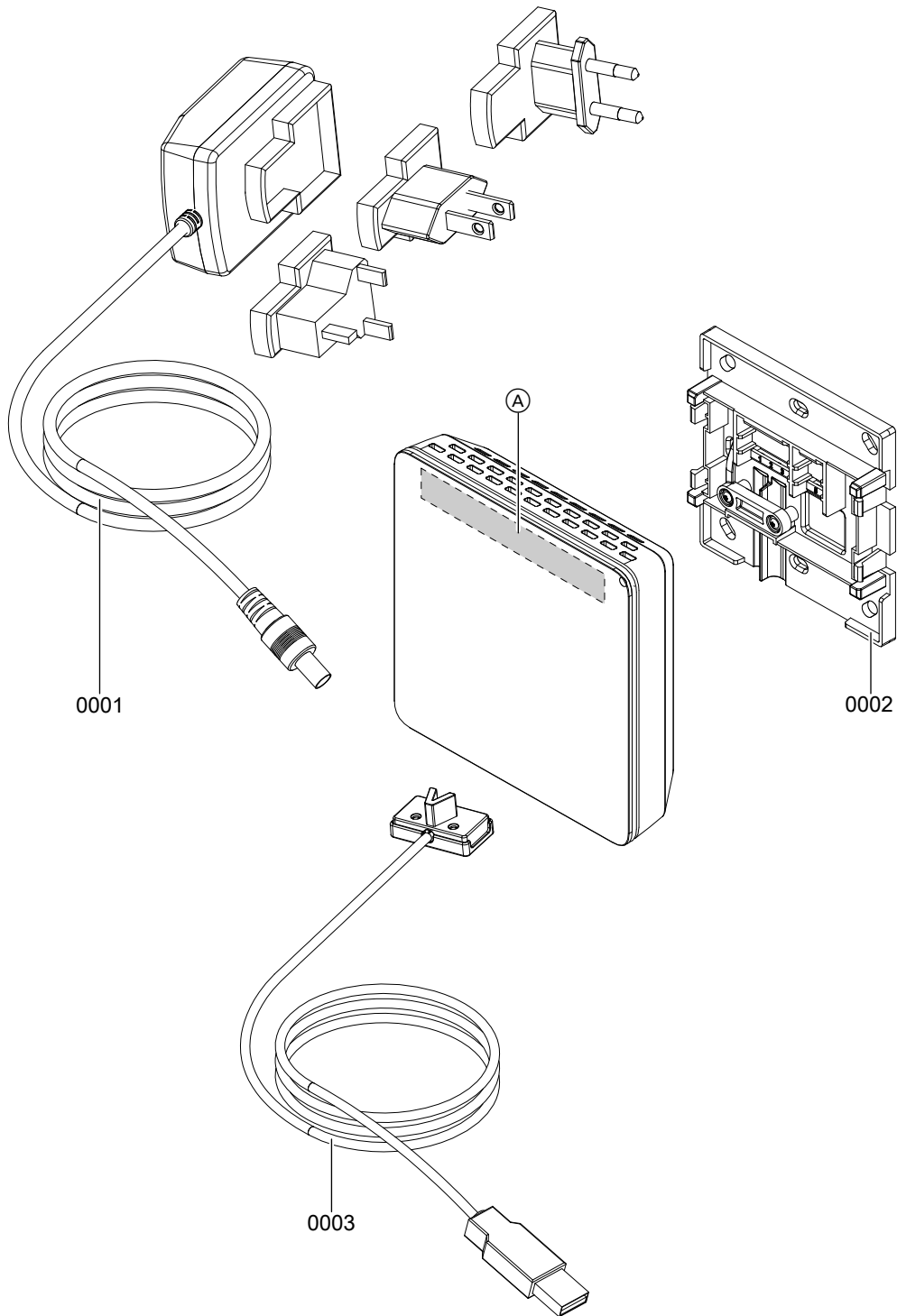

Fig. 13

- Ⓐ Vitoconnect type plate (on the rear side of the Vitoconnect)

**Parts list Vitoconnect, type OPTO2** (cont.)

<b>Item</b>	<b>Part</b>
0001	Wall power supply
0002	Wall bracket
0003	USB/Optolink connecting cable

Parts list Vitoconnect, type OT2

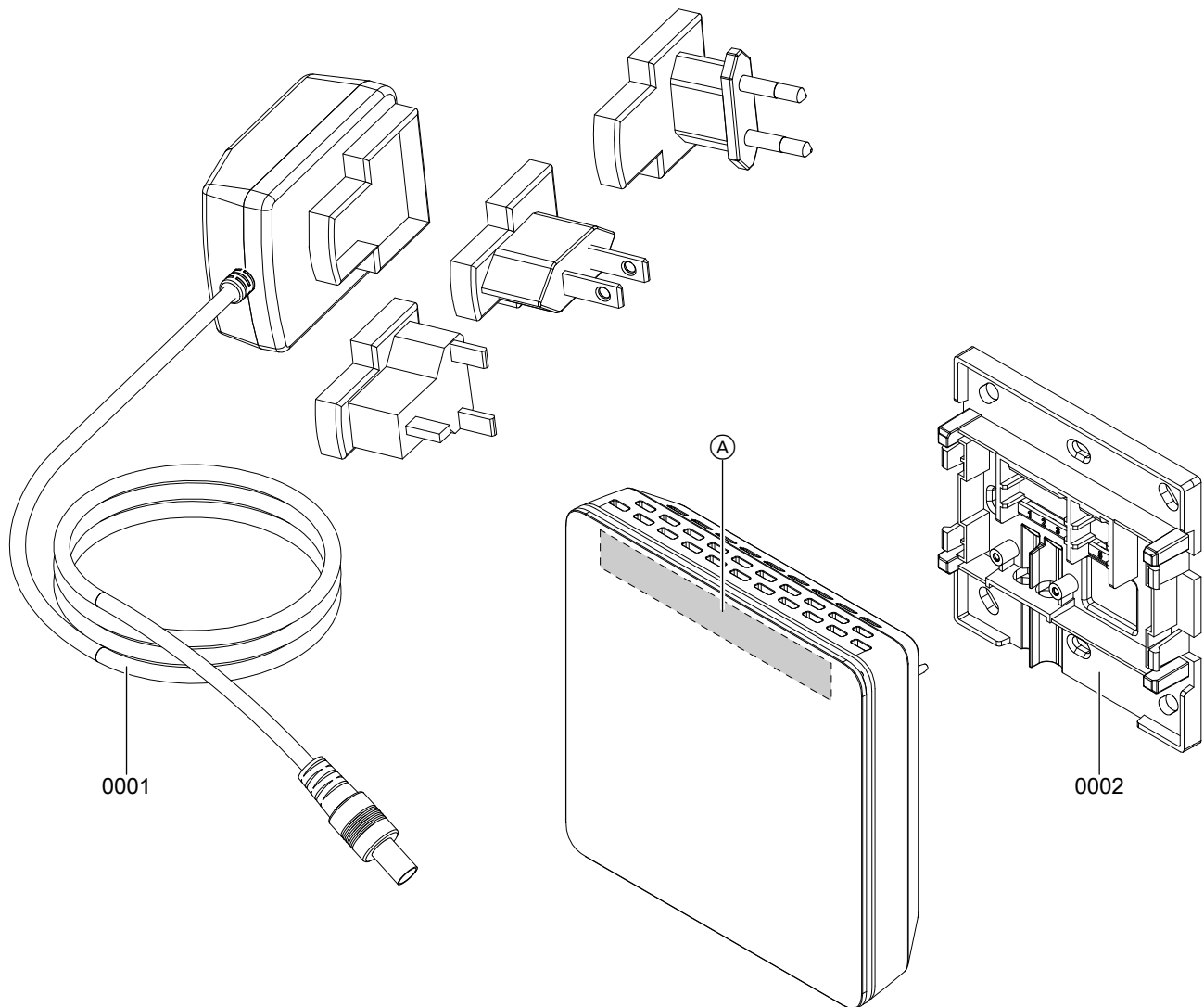

Fig. 14

- Ⓐ Vitoconnect type plate (on the rear side of the Vitoconnect)

**Parts list Vitoconnect, type OT2 (cont.)**

<b>Item</b>	<b>Part</b>
0001	Wall power supply
0002	Wall bracket

## Specification

### Specification

#### Vitoconnect

Rated voltage	12 V $\overline{=}$
Wi-Fi frequency	2.4 GHz
Wi-Fi encryption	Unencrypted or WPA2
Frequency band	2400.0 to 2483.5 MHz
Max. transmitting power	0.1 W (e.i.r.p.)
Internet protocol	IPv4
IP assignment	DHCP
Rated current	1 A
Power consumption	5.5 W
Protection class	III
IP rating	IP 20 D according to EN 60529
Permissible ambient temperature	
▪ Operation	5 to +40 °C Use in living rooms and boiler rooms (normal ambient conditions)
▪ Storage and transport	-20 to +60 °C

#### Wall power supply

Rated voltage	100 to 240 V $\sim$
Rated frequency	50/60 Hz
Output voltage	12 V $\overline{=}$
Output current	1 A
Protection class	II
Permissible ambient temperature	
▪ Operation	5 to +40 °C Use in living rooms and boiler rooms (normal ambient conditions)
▪ Storage and transport	-20 to +60 °C

#### Vitotrol 100, type OT1

Supply voltage	Via OpenTherm connecting cable
IP rating	IP 20
Permissible ambient temperature	
▪ Operation	0 to +40 °C at relative humidity from 10 to 90 % Use in living rooms and boiler rooms (normal ambient conditions)
▪ Storage and transport	-20 to +55 °C

## Keyword index

- A**  
 Access point mode  
 – Activating.....21  
 – Deactivating..... 21  
 Ambient temperature  
 – Vitoconnect..... 10  
 – Vitotrol 100, type OT1..... 10  
 App.....8
- C**  
 Closing Vitotrol 100, type OT1..... 17  
 Commissioning..... 18, 20
- D**  
 Data connections  
 – With Vitoconnect, type OPTO2..... 7  
 – With Vitoconnect, type OT2..... 7  
 DHCP..... 10  
 Display elements..... 18  
 DSL router..... 19  
 Dynamic IP addressing..... 10
- E**  
 Electrical connection  
 – Vitoconnect, type OPTO2 to heat generator..... 14  
 – Vitoconnect, type OT2 to the heat generator..... 15  
 – Vitoconnect, type OT2 to Vitotrol 100..... 16  
 email.....5  
 End devices  
 – Operating system..... 10  
 Erection..... 12  
 Establishing a connection  
 – Wi-Fi Android operating system..... 20  
 – Wi-Fi iOS operating system:..... 20
- F**  
 Fault display..... 22  
 Forwarding messages.....9  
 Frost protection..... 5  
 Functions ViCare app.....8  
 Functions Vitoguide.....8
- G**  
 General Terms and Conditions of Sale apply.....5
- I**  
 Inserting in the wall bracket  
 – Vitoconnect..... 16  
 – Vitotrol 100..... 17  
 Installation site  
 – Vitoconnect..... 10  
 – Vitotrol 100, type OT1..... 10  
 Installing the wall bracket  
 – Vitoconnect..... 13  
 – Vitotrol 100..... 14  
 Intended use..... 6  
 Internet access.....5  
 IP address..... 19  
 IP addressing..... 10  
 IP network..... 8
- L**  
 Liability..... 5
- M**  
 Mains connection  
 – Vitoconnect, type OPTO2..... 17  
 – Vitoconnect, type OT2..... 17  
 Maintenance mode  
 – Activating.....23  
 – Deactivating..... 23  
 Malfunctions..... 22  
 Measures for troubleshooting..... 22  
 Message code.....9  
 Message forwarding.....9  
 Message text.....9  
 Message type.....9
- N**  
 Network..... 8  
 Network operator.....5  
 Network settings..... 19
- O**  
 Operating elements..... 18  
 Operating functions ViCare app..... 8  
 Operating functions Vitoguide..... 8  
 Operating program  
 – Warm for long.....21  
 Operating system..... 10  
 Operating unit  
 – for ViCare app..... 10  
 Operation..... 8  
 Operational safety.....5  
 Order no.  
 – Vitoconnect, type OPTO2..... 26  
 – Vitoconnect, type OT2.....28
- P**  
 Part number  
 – Vitoconnect, type OPTO2..... 26  
 – Vitoconnect, type OT2.....28  
 Parts list  
 – Vitoconnect, type OPTO2..... 26  
 – Vitoconnect, type OT2.....28  
 Port 123..... 10, 19  
 Port 443..... 10, 19  
 Port 80..... 10, 19  
 Port 8883..... 10, 19  
 Prerequisites..... 5  
 Product information..... 7
- R**  
 Range of Wi-Fi connections..... 11  
 Registering users..... 20  
 Register user..... 12  
 Remote monitoring..... 8  
 Remote operation..... 8  
 Replacing the router..... 23  
 Reset..... 23  
 Reset button..... 23

## Keyword index (cont.)

Restarting the Vitoconnect.....	22	<b>T</b>	
Restoring delivered condition.....	23	Terms and Conditions of Sale.....	5
Room temperature.....	21	Troubleshooting.....	22
<b>S</b>		<b>U</b>	
Security parameters.....	10	User account.....	10
Setting up the heating system.....	20	<b>V</b>	
Setting up the system.....	20	ViCare app.....	8
Setting up Wi-Fi		Vitoguide.....	8
– After replacing the Wi-Fi router.....	23	Vitotronic control unit.....	8
– Android operating system commissioning.....	20	<b>W</b>	
– iOS operating system commissioning.....	20	Wall bracket installation	
Set up heating system.....	12	– Vitoconnect.....	13
Set up system.....	12	– Vitotrol 100.....	14
Spare parts		Wi-Fi connection range.....	11
– Vitoconnect, type OPTO2.....	26	Wi-Fi router.....	10
– Vitoconnect, type OT2.....	28	WPA2 password.....	20, 23
Specifications			
– Vitoconnect.....	30		
– Vitotrol 100, type OT1.....	30		
– Wall power supply.....	30		
Supported control units.....	10		
System requirements			
– IP network.....	10		



Viessmann Manufacturing Company (U.S.) Inc.  
45 Access Road  
Warwick, Rhode Island · 02886 · USA  
TechInfo Line 1-888-484-8643  
1-800-288-0667 · Fax (401) 732-0590  
www.viessmann-us-com · info@viessmamm-us.com

Viessmann Manufacturing Company Inc.  
750 McMurray Road  
Waterloo, Ontario · N2V 2G5 · Canada  
TechInfo Line 1-888-484-8643  
1-800-387-7373 · Fax (519) 885-0887  
www.viessmann.ca · info@viessmann.ca