

DUO 220 / DUO 220 AM

Dual Technology Microwave/PIR Intrusion Detectors



Installation Instructions

1. INTRODUCTION

The DUO 220 (MW/PIR) and DUO 220AM (MW/PIR/anti-masking) are state-of-the-art, microcomputer controlled dual-technology intrusion detectors. The PIR and MW technologies, when combined in a single detector, complement each other to assure the most reliable detection and immunity to false alarms.

The superiority of the DUO 220 series over other dual detectors has been achieved by the advent of the **True Motion Recognition™** algorithm (patented). This advanced motion analysis method provides the DUO 220 with the ability to distinguish between the true motion of a human body and any other disturbances which invariably cause false alarms.

Another unique feature of the DUO 220 is the **MW Motion Simulator** circuit (patents applied for), that simulates the effect created by a human body moving in the MW field. The simulation routine is carried out periodically for self-testing, supervision and assurance that the MW detector operates properly.

In addition, the pyroelectric sensor and its circuitry are tested at regular intervals by application of a short-duration heat pulse. If they do not react properly, a trouble alert is initiated.

To complement the detection pattern provided by the front lens, the DUO 220 is fitted with a down looking lens at the bottom part of the front cover. The purpose of this lens is to prevent access to the detector by sneaking below it.

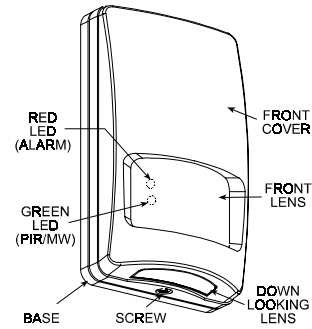

Figure 1. DUO 220 General View

2. SPECIFICATIONS

GENERAL

Input Voltage: 9 to 16 VDC

Current Drain: About 26 mA @ 12 VDC

Masking Detection Delay (DUO-220 AM): About 60 seconds

PIR SECTION

Lens Data: 34 beams, 90° field of view

Max. Coverage: 12 x 12 m (40 x 40 ft)

Vertical Adjustment: +2° to -12°, with a vertical adjustment scale

Detector: Low noise dual-element pyroelectric sensor

Trip Indication: Green LED flashes for up to 5 seconds

True Motion Verification: Selectable, 1 or 2 motion events

MW SECTION

Oscillator: Microstrip DRO-stabilized type

Frequency (GHz): 2.45

Detection Range: Adjustable from 25% to 100% (3 m to 12 m)

Trip Indication: Green LED illuminates for up to 5 seconds

ALARM, TAMPER & TROUBLE DATA

Alarm Indication: Red LED illuminates for 2-3 seconds if both detectors trip

Relay Contacts: Normally closed, 0.1 A resistive / 30 VDC; 18Ω resistor in series with contacts

Alarm Duration: 2-3 seconds (red LED lights and output relay contacts open)

Tamper Switch Contacts: N.C., 50 mA resistive /30 VDC

Trouble Output: Open collector, 100 mA max.

Trouble/Masking Indication: LEDs flash alternately and TRB output pulls LOW

PHYSICAL CHARACTERISTICS

Dimensions (H x W x D): 104 x 60 x 35 mm (2.4 x 4.1 x 1.38 in.)

Weight: 86 g (3 oz)

MOUNTING

Direct: Surface or corner (without brackets), up to 2.4 m (8 ft)

ACCESSORIES (see Fig. 4)

BR-1: Surface mounted swivel bracket, adjustable 30° down and 45° left/45° right.

BR-2: BR-1 with corner adapter (kit)

BR-3: BR-1 with ceiling adapter (kit)

ENVIRONMENTAL CONDITIONS

Operating Temperature:

-10°C to 50°C (14°F to 122°F)

Storage Temperature:

-20°C to 60°C (4°F to 140°F)

RFI Protection: >30 V/m (20 MHz to 1000 MHz)

PATENTS: U.S. Patents 5,237,330 and 5,693,943; Des. 346,567

Compliance with Standards: EN 50131-1 Grade 2 Class II

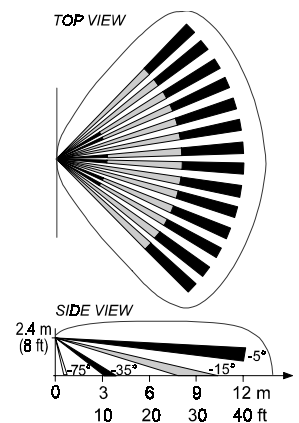

Figure 2. PIR and MW Coverage Pattern

3. INSTALLATION

3.1 General Guidelines

A few important rules must be observed before selecting a mounting location.

- Microwave radiation passes through glass and non-metallic walls. Be sure to adjust the MW range so that it does not exceed the room limits, or else a rotating ceiling fan in the next room, or moving traffic along the outer side of the wall will cause the MW detector to alarm.
- Large reflecting objects (especially metals) within the coverage area can distort the microwave detector's coverage pattern.

- Although the DUO 220 is extremely immune to false alarms, it is recommended to avoid installation in a room with very strong air turbulence or close to high-power electrical cables.
- If two DUO 220 units are installed in the same room or on opposite sides of a shared wall, they should not face each other and must be mounted at least 2 meters apart.
- For best performance at high ambient temperatures, aim the unit towards the coolest place in the protected area.
- Always mount the unit on a firm and stable surface at a height that renders optimum coverage of the protected area.

Increasing the vertical angle at a certain height will increase the coverage range.

- Do not install the DUO 220 in places where one of the two detector circuits alarms constantly or intermittently, due to environmental interference.
- **Special advice to DUO 220AM users:** It is desirable to mount the unit in locations where inadvertent approach to less than 1 m (3 ft) from the detector is unlikely to occur.

3.2 Direct Mounting

The unit can be installed directly on the wall or in a corner using the mounting knockouts. Optional swivel brackets permit greater flexibility when adjusting the coverage area (see Para. 3.3).

- Loosen and remove the screw at the bottom of the case (Fig. 1) and then take the cover off.
- Punch out the appropriate mounting and wiring knockouts in the base.

Note: For wall surface mounting, use the two elongated knockouts at the middle of the base. For corner mounting, use two diagonally opposite knockouts at the angled sides of the base (Fig. 3).

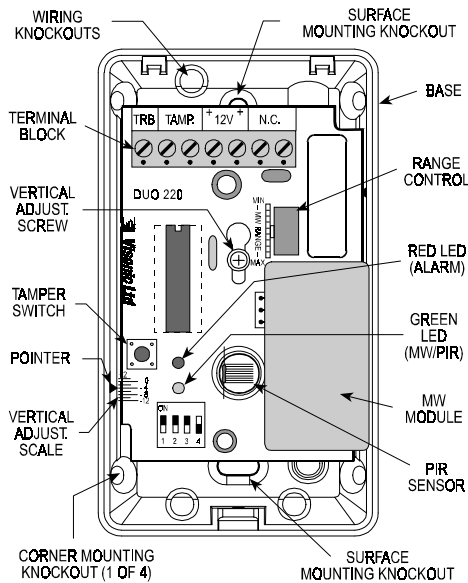

Figure 3. Printed Circuit Board Layout

- Select the mounting location in accordance with the guidelines in Para. 3.1.
- Temporarily remove the PC board from the base. Take care not to lose the fastening screw.
- Use the base as a template for marking the drilling points.
- Drill the mounting holes and insert masonry anchors if required.
- Pass the wires through the punched-out wiring inlet(s) and mount the base in place using two screws.
- Seal all openings in the base with RTV to prevent insects from entering the unit.
- Remount the PC board and secure it with its vertical adjustment screw.

3.3 Optional Swivel Brackets

The BR-1 is a general purpose swivel bracket used for vertical and horizontal positioning of the DUO 220. With the BR-1, the unit can be tilted down from 0° to -30° and swiveled 45° left or right (see Fig. 4).

The BR-2 is a swivel bracket kit for room corner installations. It consists of the BR-1 and a corner adapter.

The BR-3 is a swivel bracket kit for ceiling installations. It consists of the BR-1 and a ceiling mounting adapter.

Caution! When a swivel bracket is used, the effective detection range may differ from that indicated in Table 3 (Para. 5.1).

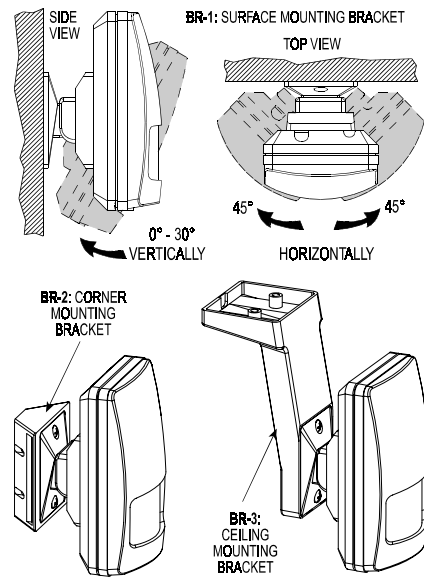

Figure 4. Optional Swivel Brackets

3.4 Wiring

Connect wires to the terminal block in the following order (Fig. 5):

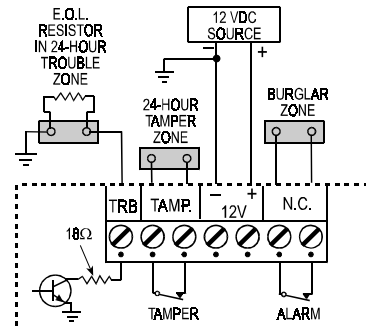

Figure 5. Terminal Block Wiring

Terminal: TAMP (tamper switch)

Connect to: A normally closed 24-hour tamper zone of the control panel.

Details: When the cover is removed, the tamper switch opens.

Terminal: NC (alarm relay)

Connect to: Normally closed burglar protection zones of the control panel.

Details: Upon alarm or power failure, the output relay's normally closed contacts open.

Terminal: TRB (trouble output)

Connect to: 24-hour trouble zone, parallel to an E.O.L. resistor (see Figure 5).

Details: The TRB open collector output will be grounded upon detector malfunction or upon masking (DUO 220AM), causing disturbance in the trouble zone of the associated alarm system.

Alternative: a buzzer or an interface relay may be connected across the TRB output and the 12 VDC (+) terminals.

Terminals: 12 V (+) and (-)

Connect to: A power source within the range of 9 to 16 VDC. Take care not to reverse the polarity.

Details: It is advisable to connect the power source only after all other connections have been completed and rechecked. Disconnect the AC mains from the alarm control panel and verify that the voltage supplied to the detector is above 9 Volts with the backup battery as the only power source.

IMPORTANT: To comply with CE safety requirements, connect to CE-approved control panels with current-limited DC output.

Note: Use RTV to seal the base opening(s) to prevent insects from entering the detector.

3.5 The Power-up Process

After connecting the (+) and (-) terminals to the power source, the DUO 220 starts a 60-second warm-up period, indicated by alternate flashing of both LEDs.

Caution! If the alternate flashing of the LEDs does not stop within 60 seconds, a failure has been detected by the self-test circuitry or, if you are dealing with DUO 220AM, the unit may be masked (see Para. 3.6).

4. INDICATORS AND SELECTORS

4.1 LED Indications

The two LEDs (Fig. 1) are used to signal various alarm and trouble messages as shown in Table 1 below:

Table 1. Interpreting the LED Indications

State of LEDs		Significance
GREEN	RED	
Off	Off	No detection
On	Off	MW walk-test detection
Flashes	Off	PIR walk-test detection
Off	On	Alarm: MW + PIR detection
Flashes	Flashes	Trouble (or masking) is being detected by the self test circuitry, or Initial warm-up routine (stops 60 seconds after power up).

Notes: 1. During walk testing, the first LED to respond is the green one. It illuminates steadily (MW detection) or flashes (PIR detection), depending on which one of the two detectors discovered the motion first. Upon subsequent discovery of the motion by the other detector, the green LED will go off and the red LED will illuminate (alarm).

2. If the green and red LEDs continue to flash beyond the warm-up period, a malfunction or masking has been diagnosed. Replace the unit without delay.

3.6 What Happens in Case of Masking?

If an attempt is made to stick masking material over the lens or put a masking object close to the lens (DUO 220AM only), a trouble alert will result about 60 seconds after masking:

- The red and green LEDs will flash alternately;
- The TRB output will pull to ground and will remain grounded until the detector is reset (see Para. 5.6 for procedure).

4.2 Mode Selector

The DIP switch mode selector is mounted on the unit's PC board (see Fig. 3). It controls four functions as demonstrated in Fig. 6 and as detailed in Table 2.

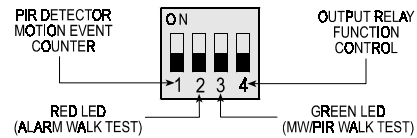

Figure 6. DIP Switch Mode Selector

Table 2. Mode Selector Switch Functions

Switch	State	Function	Default
SW-1	OFF	One motion event trips the PIR	ON
	ON	Two motion events trip the PIR	
SW-2	OFF	Alarm walk test is disabled*	ON
	ON	Alarm walk test is enabled	
SW-3	OFF	MW/PIR walk test is disabled	ON
	ON	MW/PIR walk test is enabled	
SW-4	OFF	Output relay opens upon alarm	OFF
	ON	Output relay opens upon alarm and/or when trouble is detected.	

*Setting SW-2 and SW-3 to OFF does not disable the trouble indication (flash/flash).

5. ADJUSTMENT AND TEST

5.1 Adjusting the Vertical Angle

The vertical adjustment scale for the PIR detector is located at the lower left edge of the PC board (see Figure 3). A screw in the middle of the board allows fast and easy adjustment from +2° to -12°. All DUO 220 units are pre-adjusted in the factory to -5°.

Table 3 below provides recommended vertical adjustment angles for various combinations of mounting height and coverage angle.

- A. Use Table 3 to find the optimum angle for the coverage you require. For example, if a coverage range of 9 m (30 ft) is required and the detector is installed at a height of 1.8 m (6 ft) above the floor, set the vertical angle to -6°.

Table 3. Vertical Angle Adjustment

Mounting Height	Coverage Range									
	ft	7	10	13	17	20	23	26	30	40
3	1	0°	0°	0°	0°	0°	0°	0°	0°	0°
4	1.2	-8°	-6°	-5°	-4°	-3°	-2°	-2°	-2°	-1°
5	1.5	-	-12°	-9°	-7°	-6°	-5°	-5°	-4°	-3°
6	1.8	-	-	-	-11°	-9°	-8°	-7°	-6°	-5°
7	2	-	-	-	-	-12°	-10°	-9°	-8°	-6°
8	2.5	-	-	-	-	-	-	-11°	-10°	-7°

- B. Loosen the vertical adjustment screw, slide the PC board along the vertical slot until the pointer indicates the required angle on the scale. Then tighten the adjustment screw firmly.

Note: Since the adjustment screw also fastens the PC board to the base, vertical adjustment should be repeated if the PC board is replaced.

5.2 Setting the Motion Event Counter

If you wish to set the PIR detector for maximum false alarm immunity, shift DIP switch 1 (SW-1) to ON. In this position, two consecutive motion events are required to trip the PIR detector.

For faster catch performance, shift SW-1 to OFF. In this position, only one motion event is required to trip the PIR detector.

5.3 PIR Walk Test

- Rotate the MW RANGE control all the way towards MIN.
- Verify that DIP switch SW-3 is set to ON (the green walk-test LED is enabled).
- Mount the front cover in place.
- Walk into the detector's field of view at the expected far edge of the coverage area. The green LED should flash for up to 5 seconds each time your motion is detected.

Note: If the green LED illuminates steadily, your motion has been detected by the MW detector.

- If PIR detection is not obtained at the far end of the coverage area, remove the front cover and re-adjust the vertical angle. Replace the cover and retest.

5.4 MW Walk Test

- Remove the front cover.
- Verify that the MW range control is set to MIN and DIP switch SW-3 is set to ON (the green walk-test LED is enabled). Close cover.
- Start by moving into the coverage area at the far edge. The green LED should light steadily for up to 5 seconds each time your motion is detected.
- If your motion was not detected at the far edge of the coverage area, advance the MW RANGE control slightly toward MAX and try again until your motion is detected reliably at the far edge.

Caution! The MW detection range must not exceed the far edge of the desired coverage area.

- E. Walk across the coverage area at various ranges and verify that your motion is consistently detected.

Note: If PIR trips interfere with your test, disable the PIR by inserting a small piece of cardboard in front of the sensor.

5.5 Alarm Walk Test

- Set DIP switches SW-2 and SW-3 to ON (both LEDs are enabled).
- Install the front cover in place.
- Walk across the detector's field of view in different directions, at various distances from the detector, and verify proper detection throughout the detector's coverage area (the red LED will illuminate for 2 to 3 seconds).
- When done, remove the cover and set DIP switches SW-2 and SW-3 to OFF to prevent unauthorized people from tracing the coverage pattern.
- Remount the cover and fasten it to the base using the small screw at the bottom.

Attention! To assure proper function of the detector, the range and coverage area should be checked at least twice a year. Furthermore, it is recommended to perform a walk test at the far end of the coverage pattern to assure an alarm signal prior to each time the alarm system is armed.

5.6 Resetting after Trouble (DUO 220 AM)

In case of trouble alert, proceed as follows:

- Search for masking material on the lens or a masking object in front of the lens and remove them, if found.
- Reset the detector by walk testing - cross its field of view at the far end, causing it to alarm several times.

If everything is back to normal, the red and green LEDs should stop flashing, and the TRB output should revert to the open-circuit state (disconnected from the ground).

Note: If walk testing does not cause the trouble alert to stop, recheck for masking. Once masking is ruled out, the trouble is probably due to defective PIR or MW circuitry. Replacing the detector unit will solve this problem.

6. SPECIAL NOTES

Although this detector is a highly reliable device, it does not guarantee complete protection against intrusion. Even the most sophisticated detectors can sometimes be defeated or may fail to warn because:

- The detector will not function if the DC power supplied to it is incorrect or improperly connected.
- Detection is confined to the area covered by the detection pattern as adjusted by the installer.
- A PIR detector does not provide full volumetric coverage of the protected area. It can only detect motion that disturbs the sensitive beam array spread within the protected space.
- Motion will not be detected by PIRs if it takes place behind closed doors, floors, walls, ceilings, glass partitions, windows and shutters.
- The detection ability of the PIR detector may be reduced by malicious masking or by spraying various materials on the optical lens. Mechanical tampering may also damage the optical system.
- As the ambient temperature of the protected area approaches the range of 32°C - 40°C (90°F -105°F), the PIR detector's performance can decrease.
- The protection pattern provided by the microwave detector may be altered by metal objects or foil-covered insulation.

- Even the most reliable electrical devices, including this detector, may go wrong because of an unexpected failure of a component part.

The above list includes the most common reasons for failure to detect intrusion, but it is by no means comprehensive. It is therefore recommended that the detector and the entire alarm system be checked weekly, to ensure proper performance.

An alarm system should not be regarded as a substitute for insurance. Home and property owners or renters should be prudent enough to continue insuring their lives and property. This device complies with Part 15 of the FCC Rules and RSS-210 of Industry and Science Canada. Operation is subject to the following two conditions: (1) This device may not cause harmful interference, and (2) this device must accept any interference received, including interference that may cause undesired operation.

WARNING! Changes or modifications to this unit not expressly approved by the party responsible for compliance could void the user's authority to operate the equipment.

This device complies with the essential requirements and provisions of Directive 1999/5/EC of the European Parliament and of the Council of 9 March 1999 on radio and telecommunications terminal equipment.

WARRANTY

Visonic Ltd. and/or its subsidiaries and its affiliates ("the Manufacturer") warrants its products hereinafter referred to as "the Product" or "Products" to be in conformance with its own plans and specifications and to be free of defects in materials and workmanship under normal use and service for a period of twelve months from the date of shipment by the Manufacturer. The Manufacturer's obligations shall be limited within the warranty period, at its option, to repair or replace the product or any part thereof. The Manufacturer shall not be responsible for dismantling and/or reinstallation charges. To exercise the warranty the product must be returned to the Manufacturer freight prepaid and insured.

This warranty does not apply in the following cases: improper installation, misuse, failure to follow installation and operating instructions, alteration, abuse, accident or tampering, and repair by anyone other than the Manufacturer.

This warranty is exclusive and expressly in lieu of all other warranties, obligations or liabilities, whether written, oral, express or implied, including any warranty of merchantability or fitness for a particular purpose, or otherwise. In no case shall the Manufacturer be liable to anyone for any consequential or incidental damages for breach of this warranty or any other warranties whatsoever, as aforesaid.

This warranty shall not be modified, varied or extended, and the Manufacturer does not authorize any person to act on its behalf in the modification, variation or extension of this warranty. This warranty shall apply to the Product only. All products, accessories or attachments of others used in conjunction with the Product, including batteries, shall be covered solely by their own warranty, if any. The Manufacturer shall not be liable for any damage or loss whatsoever, whether directly, indirectly, incidentally, consequentially or otherwise, caused by the malfunction of the Product due to products, accessories, or attachments of others, including batteries, used in conjunction with the Products.

The Manufacturer does not represent that its Product may not be compromised and/or circumvented, or that the Product will prevent any death, personal and/or bodily injury and/or damage to property resulting from burglary, robbery, fire or otherwise, or that the Product will in all cases provide adequate warning or protection. User understands that a properly installed and maintained alarm may only reduce the risk of events such as burglary, robbery, and fire without warning, but it is not insurance or a guarantee that such will not occur or that there will be no death, personal damage and/or damage to property as a result.

The Manufacturer shall have no liability for any death, personal and/or bodily injury and/or damage to property or other loss whether direct, indirect, incidental, consequential or otherwise, based on a claim that the Product failed to function. However, if the Manufacturer is held liable, whether directly or indirectly, for any loss or damage arising under this limited warranty or otherwise, regardless of cause or origin, the Manufacturer's maximum liability shall not in any case exceed the purchase price of the Product, which shall be fixed as liquidated damages and not as a penalty, and shall be the complete and exclusive remedy against the Manufacturer.

Warning: The user should follow the installation and operation instructions and among other things test the Product and the whole system at least once a week. For various reasons, including, but not limited to, changes in environmental conditions, electric or electronic disruptions and tampering, the Product may not perform as expected. The user is advised to take all necessary precautions for his/her safety and the protection of his/her property.

6/91



W.E.E.E. Product Recycling Declaration

For information regarding the recycling of this product you must contact the company from which you originally purchased it. If you are discarding this product and not returning it for repair then you must ensure that it is returned as identified by your supplier. **This product is not to be thrown away with everyday waste.** Directive 2002/96/EC Waste Electrical and Electronic Equipment.



VISONIC LTD. (ISRAEL): P.O.B 22020 TEL-AVIV 61220 ISRAEL. PHONE: (972-3) 645-6789, FAX: (972-3) 645-6788

VISONIC INC. (U.S.A.): 65 WEST DUDLEY TOWN ROAD, BLOOMFIELD CT. 06002-1376. PHONE: (860) 243-0833, (800) 223-0020 FAX: (860) 242-8094

VISONIC LTD. (UK): FRASER ROAD, PRIORY BUSINESS PARK, BEDFORD MK44 3WH. PHONE: (0870) 7300800 FAX: (0870) 7300801

INTERNET: www.visonic.com

©VISONIC LTD. 2008 DUO 220 / DUO 220 AM DE1823- (preparation for revision 6 , 4/08)



MADE IN ISRAEL