

1. INTRODUCTION

The MC-312 PG2 is a two-way wireless PowerG magnetic contact device that is compatible with PowerMaster control panels.

The device has the following features:

- Weatherproof, water-resistant outdoor transceiver
- Functions in extreme temperature (-40 °C to 66 °C / -40 °F to 151 °F) and is IP66 certified.
- Battery life of up to 5 years (with typical use)
- Integrated magnetic sensor
- Anti-masking protection, based on panel software version.
- Auxiliary hard-wired input, programmable as either NO, NC, EOL or DEOL (based on panel version support) for use with additional devices
- Maximum magnet gap of 44.5 mm (1¾ in) on wood and 31.8 mm (1¼ in) on metal.
- Ability to disable the magnetic sensor if the auxiliary input only is required
- The sensor and the auxiliary input can behave as separate transmitters, although they trigger the same RF transmitter.
- Front and back tamper protection (back tamper not available in US market)
- Automatic periodic supervision at regular intervals
- PowerG two-way Frequency Hopping Spread Spectrum FHSS-TDMA technology

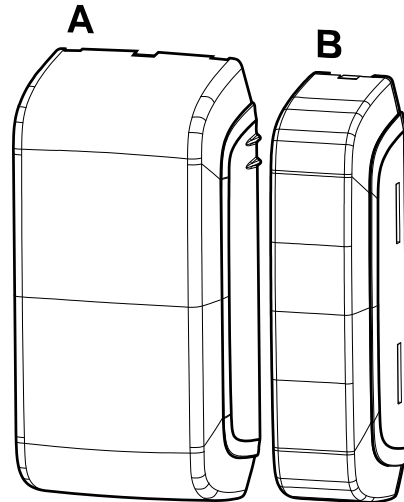

Figure 1 - MC-312 PG2

A: Device B: Magnet

2. INSTALLATION

The equipment is designed to be installed only by qualified service persons.

It is recommended to place the transmitter above the door or window on the fixed frame and the magnet to the movable part of the door or window. Make sure that the magnet is located not more than 44 mm (1.75 in) from the marked side of the transmitter.

It is also possible to mount the MC-312 PG2 on a curved surface, such as a fence pole or similar, to monitor outdoor areas.

In case of roller shutter assembly, the magnet needs to be assembled 25mm – 35mm from the sensor.

Note: Once the battery cover is removed, a tamper message is transmitted to the panel. Subsequent removal of the battery prevents transmission of the TAMPER RESTORE alert, leaving the receiver in permanent alert. To avoid this, press the tamper switch when you remove the battery.

Caution! Risk of explosion if the battery is replaced by an incorrect type. Dispose of the used battery according to the manufacturer's instructions.

Attention! The unit has an optional back tamper switch behind the device. As long as the device is seated firmly within the bracket, the switch lever will be pressed against a special break-away bracket segment that is loosely connected to the bracket. Be sure to fasten the break-away segment to the wall. If the detector unit is forcibly removed from the wall, this segment will break away from the bracket, causing the tamper switch to open.

2.1. Mounting the MC-312 PG2 on a flat surface

To mount the device on a flat surface, complete the following steps:

1. Insert a flat-head screwdriver into the slot provided and push upward to remove the decorative cover, as in Fig. 2.
2. Unscrew the lower screw from the device cover, as in Fig. 3.
3. Separate the device from the bracket, as in Fig. 4.
4. Mark and drill four holes in the mounting surface, as in Fig. 5.
5. Screw in the bracket with four screws provided.
6. Reattach the device to the bracket.
7. Mount the magnet base with two supplied screws to an adjacent surface and attach the magnet to the magnet bracket, as in Fig. 5.

Note: Align the device and magnet according to the specifications in "Range coverage directions" on the next page.

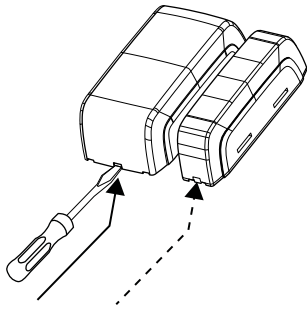

Figure 2 - Decorative cover removal

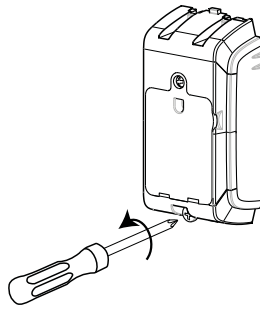

Figure 3 - Unscrewing device

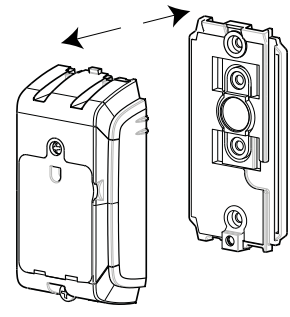

Figure 4 - Device and bracket separation

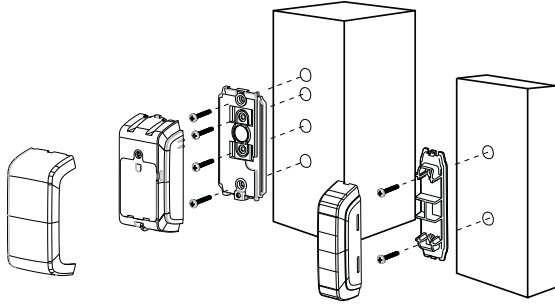

Figure 5 - Flat surface mounting

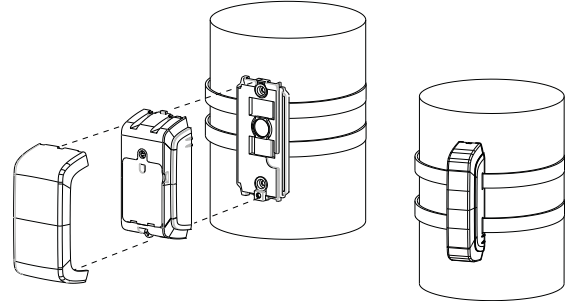

Figure 6 - Curved surface mounting

2.2. Mounting the MC-312 PG2 on a curved surface

1. Insert a flat-head screwdriver into the slot provided and push upward to remove the decorative cover, as in Fig. 2.
2. Unscrew the lower screw from the device cover, as in Fig. 3.
3. Separate the device from the bracket, as in Fig. 4.
4. Feed both straps through the slots provided in the bracket, as in Fig. 6.
5. Fasten both straps to the desired curved surface and position the connecting sections of the straps at the location of the bracket.
6. Separate the magnet bracket and cover and feed both straps through the slots provided on the cover.
7. Close the magnet and fasten both straps to the desired curved surface and position the connecting sections of the straps at the location of the bracket.

Note: Align the device and magnet according to the specifications in "Range coverage directions" below.

2.3. Range coverage directions

Non-metallic surface		Supports	Metallic surface	
Open	Close		Open	Close
71 mm	52 mm	Direction	48 mm	35 mm
40 mm	33 mm	X	32 mm	25 mm
22 mm	17 mm	Y (up)	17 mm	8 mm
85 mm	55 mm	Y (down)	55 mm	30 mm
		Z		

Table 1 - Range coverage directions

Note: Values stated above may vary by up to 10%. For steel installations, the gaps cannot be less than 3.2 mm.

Note: In case of roller shutter assembly, the magnet needs to be mounted 25 mm - 35 mm (on the X plane) from the device. For all other installations, a minimum gap of 5 mm is needed.

Tip: When mounting on a slide door, refer to X. When mounting on a roller shutter, refer to Y. When mounting on a normal door, refer to Z.

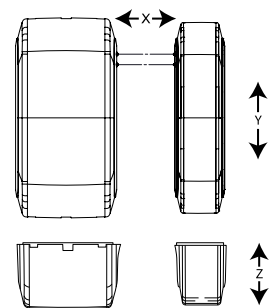

Figure 7 - Range coverage directions

2.4. Enrolling the MC-312 PG2

Refer to the relevant control panel installer guide and follow the procedure under the "02: ZONES/DEVICES" option of the Installer Menu. A general description of the procedure is provided in the following flow chart.

Step 1	Step 2	Step 3	Step 4	Step 5	Step 6
Enter the installer menu and select 02: ZONES / DEVICES	Select ADD NEW DEVICE. See note [1]	Enroll the device or enter the device ID	Select the desired zone number	Configure the location, zone type, and chime parameters	Configure the detector
02: ZONES DEVICES > ADD NEW DEVICES >				Z06: LOCATION	
ENROLL NOW or ENTER				Z06: ZONE TYPE	
ID: XXX-XXXX >				Z06: SET CHIME	
				Z06: DEV SETTINGS	
				See section 2.7	

Notes:

If the magnetic contact device is already enrolled you can configure the magnetic contact device parameters using the Modify Devices option (see step 2).

Select the Device Settings option and refer to "Configuring the MC-312 PG2 device parameters" below to configure the device parameters.

To enroll the device as noted in step 3, you can power on the device, press the enrollment button, or remove the pull tab on new devices (see Fig. 8).

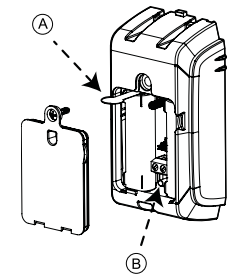

Figure 8 - Enrollment options

A: Enrollment tab

B: Enrollment button

2.5. Configuring the MC-312 PG2 device parameters

Enter the control panel **DEVICE SETTINGS** menu and follow the configuration instructions for the MC-312 PG2 magnetic contact device as described in the Table 2.

Option	Configuration instructions
Magnetic sensor	Determine whether to enable or disable the magnetic sensor.
	Optional settings: Enabled (default) or Disabled .
Input #1	Define the external input according to the installer's requirements.
	Optional settings: Disabled (default), Normally Open , Normally Closed , End of Line , or Double End of Line . Note: DEOL support is dependent on panel software version.
Anti-mask	Determine whether to enable or disable the anti-masking protection.
	Optional settings: Enabled or Disabled (default). Note: This feature is dependent on panel software version.

Table 2 - Magnetic device parameters

2.6. Wiring the auxiliary input

Notes:

For UL installations, the device connected to the initiating circuit must be located in the same room as the transmitter.

For UL installations, connect to UL listed residential burglar alarm accessories only.

For ULC installations, connect ULC listed products only to the auxiliary wiring input.

An alarm message is transmitted once the loop is opened or short circuited.

To connect this device with another nearby device via auxiliary input, complete the following steps:

1. Remove the jacket at the end of the cable to expose the wires within.
2. Perforate the silicon gasket, at the back of the device, with a 0.8 mm (1/32 in) pin.
3. Pass each wire through an entry hole and out the opposite side.
4. Remove the insulation from the end of each wire.
5. Connect each wire to the relevant terminal, referencing "Auxiliary wiring options" below.
6. Screw the terminal closed using a flat head screwdriver.

Notes:

Use a 22 AWG AUX cable for this installation.

Use a cable shorter than 3 m (10 ft) for the AUX connection.

Seal the auxiliary wiring gasket with RTV Silicone adhesive sealant.

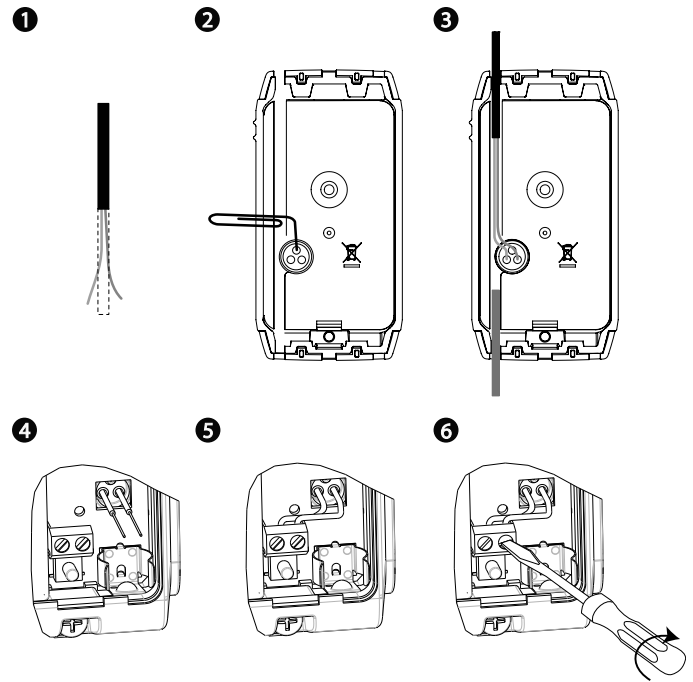

Figure 9 - Auxiliary wiring

2.7. Auxiliary wiring options

You can add more devices to the circuit of the MC-312 PG2 for normally closed, normally open or end of line applications. Each application type is explained in the table below:

Normally closed (NC)	Exclusively use series connected NC sensor contacts if the auxiliary input of the MC-312 PG2 is defined as a normally closed (NC) type. An EOL resistor is not required.
Normally open (NO)	Exclusively use parallel connected NO sensor contacts if the auxiliary input of the MC-312 PG2 is defined as NO type. An EOL resistor is not required.
End of Line (EOL)	For EOL supervision, NC sensor contacts can be used. A 5.6 kΩ EOL resistor may be wired at the far end of the zone loop.

Note: Figure 10 illustrates a DEOL (Double End of Line) resistor setup, which is available dependent on panel software version.

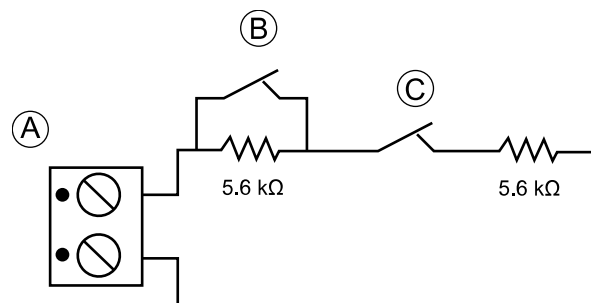

Figure 10 - DEOL wiring example

A: Terminal B: Alarm C: Tamper

3. LOCAL DIAGNOSTICS TEST

A local diagnostic test is required to establish the signal strength of a device in its current position during the installation process. To perform the mandatory test, do as follows:

1. Separate the decorative cover from the device and unscrew the battery cover, as in steps 1 - 3 in "Mounting the MC-312 PG2 on a flat surface" on page 1.
2. Press the tamper switch once (see Fig. 8) and release it.
3. Open the door or window and verify that detection is indicated by a red LED flash.
4. After two seconds the LED flashes three times in one of three colors to indicate the signal strength (see Table 3).

LED response	Reception
Green LED flashes	Strong
Yellow LED flashes	Good
Red LED flashes	Poor
No flashes	No communication

Table 3 - LED reception response

Important! Reliable reception must be assured. Therefore, "poor" signal strength is not acceptable. If you receive a "poor" signal from the detector, re-locate it and re-test until a "good" or "strong" signal strength is received (in regions requiring UL-compliant installation, only "strong" signal strength is permitted).

Note:

For UL, only strong signal strength is acceptable.

For detailed diagnostics test instructions, refer to the control panel Installer Guide.

After this step you can reattach the battery cover.

The LED light is off in normal conditions.

4. CALIBRATING THE ANTI-MASK

The anti-mask feature enables the detection of attempted sabotage (for example, obstructing the sensor). In order to enable this feature on the MC-312 PG2, complete the following steps of the anti-mask learning process:

Note: This feature is dependent on panel software version.

Pre-requisite: In order to receive an alert in the case of interference of the magnet, this function must be set in the control panel to 'Enable' in the configuration setup.

Pre-requisite: The anti-mask learning process can only be completed after enrollment (see "Enrolling the MC-312 PG2" on page 3).

1. Position the device and magnet pointers to face each other with reference to "Range coverage directions" on page 2.
2. Locate the device and magnet on the same height from the surface they are installed on (this refers to the Z plane in "Range coverage directions" on page 2).

Note: During the anti-mask learning process the sensor and the magnet must be stable for 10 seconds.

3. Press and hold the enroll button for 6-8 seconds to start the anti-mask learning process.

Note: Do not release the enroll button after 2 seconds, while the yellow LED is lit. Release the button after the green LED lights (6 seconds), but before 8 seconds.

In a case of success, the green LED will flash three times. In a case of failure, the red LED will flash three times.

Note: If the door is open while the enroll button is pressed, the anti-mask learning process will be ignored.

5. MISCELLANEOUS COMMENTS

Visonic Ltd. wireless systems are very reliable and are tested to high standards. However, due to low transmitting power and limited range (required by FCC and other regulatory authorities), there are some limitations to be considered as follows:

- A. Receivers may be blocked by radio signals occurring on or near their operating frequencies, regardless of the digital code used.
- B. A receiver responds only to one transmitted signal at a time.
- C. Wireless devices should be tested regularly to determine whether there are sources of interference and to protect against faults.

6. COMPLIANCE WITH STANDARDS



The MC-312 PG2 complies with the following standards:

Europe EN 301489, EN 50130-4, EN 300 220, EN 62368-1, EN 60950-22, EN 50130-5, EN 50131-5-3, EN 50131-6 Type C, EN 50131-2-6 Grade 2 Class IV

Hereby, Visonic Ltd. declares that the radio equipment type MC-312 PG2 is in compliance with Directive 2014/53/EU.

The full text of the EU declaration of conformity is available at the following internet address:

<http://www.visonic.com/download-center>.

EN 50131-1 Security Grade: According to EN 50131-1 this equipment can be applied in installed systems up to and including Security Grade 2.

EN 50131-1 Environmental Class: Class IV

Certified by Applica Test & Certification AS in accordance with EN 50130-4, EN 50130-5, EN 50131-5-3, EN 50131-6, EN 50131-2-6, EN 50131-1

The Power G peripheral devices have two-way communication functionality, providing additional benefits as described in the technical brochure. This functionality has not been tested to comply with the respective technical requirements and should therefore be considered outside the scope of the product's certification.



UK: The MC-312 PG2 is suitable for use in systems installed to conform to PD6662 at Grade 2 and environmental CLASS IV and BS8243

USA: FCC -CFR 47 part 15, UL- UL634, UL 1023/UL 1610

Canada: IC-RSS-247, ULC- ORD-C634, ULC S304

Note: Only devices operating at 912-919 MHz are tested and listed by UL/ULC

Note: This equipment has been tested and found to comply with the limits for a Class B digital device, pursuant to part 15 of the FCC Rules. These limits are designed to provide reasonable protection against harmful interference in a residential installation. This equipment generates, uses and can radiate radio frequency energy and, if not installed and used in accordance with the instructions, may cause harmful interference to radio communications. However, there is no guarantee that interference will not occur in a particular installation. If this equipment does cause harmful interference to radio or television reception, which can be determined by turning the equipment off and on, the user is encouraged to try to correct the interference by one or more of the following measures:

- Reorient or relocate the receiving antenna.
- Increase the separation between the equipment and receiver.
- Connect the equipment into an outlet on a circuit different from that to which the receiver is connected.
- Consult the dealer or an experienced radio / TV technician for help.

- This Class B digital apparatus complies with Canadian ICES-003.
- Cet appareil numérique de la classe B est conforme à la norme NMB-003 du Canada.

WARNING! Changes or modifications to this unit not expressly approved by the party responsible for compliance could void the user's authority to operate the equipment.

This device complies with Part 15 of the FCC Rules and with ISSED license-exempt RSS standard(s). Operation is subject to the following two conditions: (1) This device may not cause harmful interference, and (2) this device must accept any interference received, including interference that may cause undesired operation.

Le présent appareil est conforme aux CNR d'ISSED applicables aux appareils radio exempts de licence. L'exploitation est autorisée aux deux conditions suivantes : (1) l'appareil ne doit pas produire de brouillage, et (2) l'utilisateur de l'appareil doit accepter tout brouillage radioélectrique subi, même si le brouillage est susceptible d'en compromettre le fonctionnement.

To comply with FCC and IC RF exposure compliance requirements, the device should be located at a distance of at least 20 cm from all persons during normal operation. The antennas used for this product must not be co-located or operated in conjunction with any other antenna or transmitter.

Le dispositif doit être placé à une distance d'au moins 20 cm à partir de toutes les personnes au cours de son fonctionnement normal. Les antennes utilisées pour ce produit ne doivent pas être situées ou exploitées conjointement avec une autre antenne ou transmetteur.

7. SPECIAL COMMENTS

Even the most sophisticated detectors can sometimes be defeated or may fail to warn due to: DC power failure / improper connection, malicious masking of the lens, tampering with the optical system, decreased sensitivity in ambient temperatures close to that of the human body and unexpected failure of a component part.

The above list includes the most common reasons for failure to detect intrusion, but is by no means comprehensive. It is therefore recommended that the detector and the entire alarm system be checked weekly, to ensure proper performance.

An alarm system should not be regarded as a substitute for insurance. Home and property owners or renters should be prudent enough to continue insuring their lives and property, even though they are protected by an alarm system.

**W.E.E.E. Product Recycling Declaration**

For information regarding the recycling of this product you must contact the company from which you originally purchased it. If you are discarding this product and not returning it for repair then you must ensure that it is returned as identified by your supplier. This product is not to be thrown away with everyday waste. Directive 2002/96/EC Waste Electrical and Electronic Equipment.

8. APPENDIX: SPECIFICATIONS

Frequency Band (MHz)	Europe and rest of world: 433-434, 868-869 USA: 912-919
Maximum Tx Power	10 dBm @ 433 MHz 10 dBm @ 868 15 dBm @ 915 MHz
Alarm input	One internal and one auxiliary
Supervision	Signalling at 4-minute intervals
Tamper alert	Report when a tamper event occurs
Communication protocol	PowerG
Power supply	Type C
Battery type	2 x 1.5 V Ultimate Lithium Energizer battery only
Battery life expectancy	5 years with typical commercial transmissions per day (not tested by UL)
Low battery threshold	3.2 V
Battery supervision	Automatic transmission of battery condition data as part of the periodic status report and immediately upon low battery detection.
Operating Temperature	-40 °C (-40 °F) to 66 °C (151 °F)
Relative Humidity (RH)	Average relative humidity of approximately 75% non-condensing. For 30 days per year relative humidity may vary between 85% and 95% non-condensing. Note: For UL installations, relative humidity is 93%.
Dimensions (LxWxD)	105 x 52 x 35 mm (4 1/8 x 2 x 1 3/8 in)
Device weight (including battery)	154 g (5.4 oz)
Color	Dark grey

WARRANTY

Visonic Limited (the "Manufacturer") warrants this product only (the "Product") to the original purchaser only (the "Purchaser") against defective workmanship and materials under normal use of the Product for a period of twelve (12) months from the date of shipment by the Manufacturer.

This Warranty is absolutely conditional upon the Product having been properly installed, maintained and operated under conditions of normal use in accordance with the Manufacturers recommended installation and operation instructions. Products which have become defective for any other reason, according to the Manufacturers discretion, such as improper installation, failure to follow recommended installation and operational instructions, neglect, willful damage, misuse or vandalism, accidental damage, alteration or tampering, or repair by anyone other than the manufacturer, are not covered by this Warranty.

There is absolutely no warranty on software, and all software products are sold as a user license under the terms of the software license agreement included with such Product.

The Manufacturer does not represent that this Product may not be compromised and/or circumvented or that the Product will prevent any death and/or personal injury and/or damage to property resulting from burglary, robbery, fire or otherwise, or that the Product will in all cases provide adequate warning or protection. The Product, properly installed and maintained, only reduces the risk of such events without warning and it is not a guarantee or insurance that such events will not occur.

Conditions to Void Warranty: This warranty applies only to defects in parts and workmanship relating to normal use of the Products. It does not cover:

- * damage incurred in shipping or handling;
- * damage caused by disaster such as fire, flood, wind, earthquake or lightning;
- * damage due to causes beyond the control of the Seller such as excessive voltage, mechanical shock or water damage;
- * damage caused by unauthorized attachment, alterations, modifications or foreign objects being used with or in conjunction with the Products;
- * damage caused by peripherals (unless such peripherals were supplied by the Seller);
- * defects caused by failure to provide a suitable installation environment for the products;
- * damage caused by use of the Products for purposes other than those for which they were designed;
- * damage from improper maintenance;
- * damage arising out of any other abuse, mishandling or improper application of the Products.

Items Not Covered by Warranty: In addition to the items which void the Warranty, the following items shall not be covered by Warranty: (i) freight cost to the repair centre; (ii) customs fees, taxes, or VAT that may be due; (iii) Products which are not identified with the Seller's product label and lot number or serial number; (iv) Products disassembled or repaired in such a manner as to adversely affect performance or prevent adequate inspection or testing to verify any warranty claim. Access cards or tags returned for replacement under warranty will be credited or replaced at the Seller's option.

THIS WARRANTY IS EXCLUSIVE AND EXPRESSLY IN LIEU OF ALL OTHER WARRANTIES, OBLIGATIONS OR LIABILITIES, WHETHER WRITTEN, ORAL, EXPRESS OR IMPLIED, INCLUDING ANY WARRANTY OF MERCHANTABILITY OR FITNESS FOR A PARTICULAR PURPOSE, OR OTHERWISE. IN NO CASE SHALL THE MANUFACTURER BE LIABLE TO ANYONE FOR ANY CONSEQUENTIAL OR INCIDENTAL DAMAGES FOR BREACH OF THIS WARRANTY OR ANY OTHER WARRANTIES WHATSOEVER, AS AFORESAID.

THE MANUFACTURER SHALL IN NO EVENT BE LIABLE FOR ANY SPECIAL, INDIRECT, INCIDENTAL, CONSEQUENTIAL OR PUNITIVE DAMAGES OR FOR LOSS, DAMAGE, OR EXPENSE, INCLUDING LOSS OF USE, PROFITS, REVENUE, OR GOODWILL, DIRECTLY OR INDIRECTLY ARISING FROM PURCHASER'S USE OR INABILITY TO USE THE PRODUCT, OR FOR LOSS OR DESTRUCTION OF OTHER PROPERTY OR FROM ANY OTHER CAUSE, EVEN IF MANUFACTURER HAS BEEN ADVISED OF THE POSSIBILITY OF SUCH DAMAGE.

THE MANUFACTURER SHALL HAVE NO LIABILITY FOR ANY DEATH, PERSONAL AND/OR BODILY INJURY AND/OR DAMAGE TO PROPERTY OR OTHER LOSS WHETHER DIRECT, INDIRECT, INCIDENTAL, CONSEQUENTIAL OR OTHERWISE, BASED ON A CLAIM THAT THE PRODUCT FAILED TO FUNCTION. HOWEVER, IF THE MANUFACTURER IS HELD LIABLE, WHETHER DIRECTLY OR INDIRECTLY, FOR ANY LOSS OR DAMAGE ARISING UNDER THIS LIMITED WARRANTY, THE MANUFACTURER'S MAXIMUM LIABILITY (IF ANY) SHALL NOT IN ANY CASE EXCEED THE PURCHASE PRICE OF THE PRODUCT INVOLVED, WHICH SHALL BE FIXED AS LIQUIDATED DAMAGES AND NOT AS A PENALTY, AND SHALL BE THE COMPLETE AND EXCLUSIVE REMEDY AGAINST THE MANUFACTURER. SOME JURISDICTIONS DO NOT ALLOW THE EXCLUSION OR LIMITATION OF INCIDENTAL OR CONSEQUENTIAL DAMAGES, SO THESE LIMITATIONS MAY NOT APPLY UNDER CERTAIN CIRCUMSTANCES.

When accepting the delivery of the Product, the Purchaser agrees to the said conditions of sale and warranty and he recognizes having been informed of.

The Manufacturer shall be under no liability whatsoever arising out of the corruption and/or malfunctioning of any telecommunication or electronic equipment or any programs.

The Manufacturer's obligations under this Warranty are limited solely to repair and/or replace at the Manufacturer's discretion any Product or part thereof that may prove defective. Any repair and/or replacement shall not extend the original Warranty period. The Manufacturer shall not be responsible for dismantling and/or reinstallation costs. To exercise this Warranty the Product must be returned to the Manufacturer freight pre-paid and insured. All freight and insurance costs are the responsibility of the Purchaser and are not included in this Warranty.

This warranty shall not be modified, varied or extended, and the Manufacturer does not authorize any person to act on its behalf in the modification, variation or extension of this warranty. This warranty shall apply to the Product only. All products, accessories or attachments of others used in conjunction with the Product, including batteries, shall be covered solely by their own warranty, if any. The Manufacturer shall not be liable for any damage or loss whatsoever, whether directly, indirectly, incidentally, consequentially or otherwise, caused by the malfunction of the Product due to products, accessories, or attachments of others, including batteries, used in conjunction with the Products. This Warranty is exclusive to the original Purchaser and is not assignable.

This Warranty is in addition to and does not affect your legal rights. Any provision in this warranty which is contrary to the Law in the state or country where the Product is supplied shall not apply.

Governing Law: This disclaimer of warranties and limited warranty are governed by the domestic laws of Israel.

Warning

The user must follow the Manufacturer's installation and operational instructions including testing the Product and its whole system at least once a week and to take all necessary precautions for his/her safety and the protection of his/her property.

* In case of a conflict, contradiction or interpretation between the English version of the warranty and other versions, the English version shall prevail.
4/18



EMAIL: info@visonic.com

INTERNET: www.visonic.com

©VISONIC LTD. 2018 D-307174 MC-312 PG2 REV. 0, (04/18)



D-307174