



D-305291

English

MCT-340 SMA

Wireless Contact Sensor



Visonic

Installation Instructions

1. INTRODUCTION

The MCT-340 is a fully supervised, wireless magnetic contact sensor, for use with iControl H.A. 1.2 control panels. The sensor includes a built-in reed switch (that opens upon removal of a magnet placed near it).

The MCT-340 tamper switch is activated when the cover is removed.

A periodic supervision message is transmitted automatically. The target receiver is thus informed, at regular intervals, of the unit's active participation in the system.

Operating power is obtained from an on-board 3 V Lithium battery. When the battery voltage is low, a "low battery" message will be sent to the receiver 30 days before expiration of battery life.

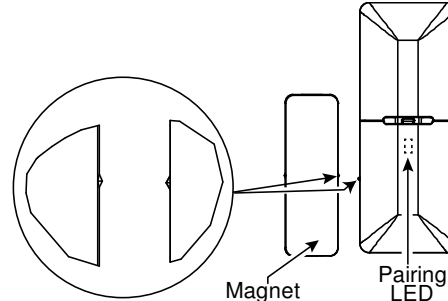

Fig. 1 - External View

2. SPECIFICATIONS

WIRELESS

Frequency: 2.4 GHz as per IEEE 802.15.4

Tamper Alert: Reported when a tamper event occurs and in any subsequent message, until the tamper switch is restored.

Supervision Message: Signaling at 27-minute intervals.

Transmission Range in Open Area: Up to 280 meters (iControl panel)

ELECTRICAL

Internal Battery: 3V Lithium battery, type CR2032. Use Varta only.

Nominal Battery Capacity: 230 mAh

Battery Life Expectancy: 3 years (for typical use).

Note: Inability to connect with wireless network, or wireless link quality no higher than 20% may significantly reduce the expected battery life.

Battery Power Test: Performed immediately upon battery insertion and periodically every several hours.

Battery Supervision: Automatic transmission of battery condition data as part of any status report.

ENVIRONMENTAL

Operating Temperature: 0°C to 55°C (32°F to 131°F).

Dimensions: 66 x 25 x 10 mm (2-9/16 x 1 x 6/16 in.)

Weight (including battery): 15g (0.5 oz)

3. ACTIVATING THE SENSOR

To activate, pull the strip (from either side) that protrudes from the back of the sensor.

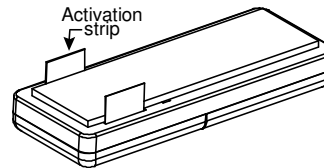

Fig. 2 - Activation Strip

4. PAIRING/DEFAULTING THE SENSOR

To pair the sensor to the control panel, you must set it to pairing mode. First set the panel to pairing mode and then the sensor.

1. Press and hold down the sensor's tamper switch (see Figure 4-4).
2. Insert the battery into the sensor (see Figure 4-4).

3. Release the tamper switch within 4 seconds (the LED blinks 3 times every 5 seconds).
4. Complete the pairing procedure on the control panel (see the pairing instructions in the control panel's installation guide).

5. INSTALLATION

CAUTION: This equipment shall be installed by Service Personnel in non-hazardous indoor locations only.

5.1 Mounting

NOTE: It is highly recommended to attach the transmitter to the top of the door/window on the fixed frame and the magnet to the movable part (door or window). Make sure that the magnet is located not more than 6 mm (0.25 in.) from the transmitter's marked side.

The transmitter should be mounted on the fixed surface and the magnet on the moving surface (see Figure 3).

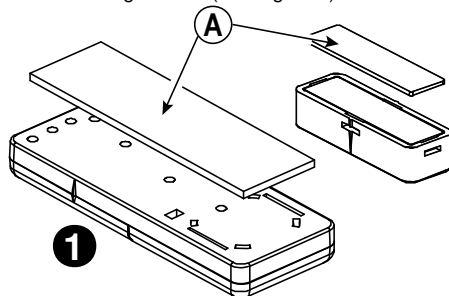

1. Peel away the release liners from the two strips of double-sided adhesive tape and attach to the device and magnet.

A. Double-sided adhesive tape

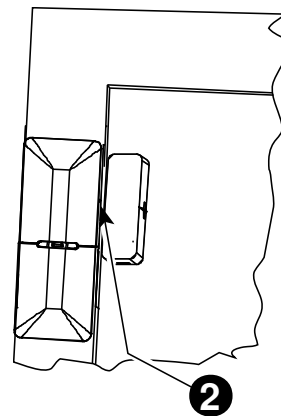

2. Align the device with the magnet according to the location marks and fasten the device and magnet to the mounting surface. The transmitter should be mounted on the fixed surface and magnet on the moving surface.

Fig. 3 - Mounting

5.2 Battery Replacement

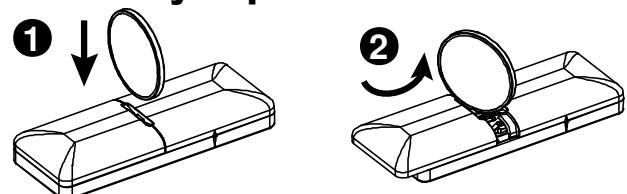

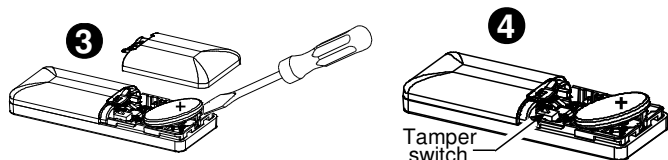

Fig. 4 – Battery Replacement

6. TESTING THE SENSOR

Close the door or window, thus restoring it to the undisturbed state.

7. TROUBLESHOOTING

If you encounter one of the following problems with the MCT-340 SMA, perform the suggested remedy:

Problem	Remedy
Attempt to pair the sensor is unsuccessful.	Make sure that the sensor has been defaulted and is set to pairing mode (see section 4). Make sure that the iControl panel supports the H.A 1.2.
The sensor and the panel do not communicate.	Perform the signal strength testing procedure described in the control panel installation manual. Make sure that the signal is sufficient. If necessary, replace the sensor's battery.

8. COMPLIANCE WITH STANDARDS

FCC

This device complies with Part 15 of the FCC Rules and RSS-210 of Industry and Science Canada. Operation is subject to the following two conditions: (1) This device may not cause harmful interference, and (2) this device must accept any interference received, including interference that may cause undesired operation.

This device complies with Industry Canada license-exempt RSS standard(s). Operation is subject to the following two conditions: (1) this device may not cause interference, and (2) this device must accept any interference, including interference that may cause undesired operation of the device.

Le présent appareil est conforme aux CNR d'Industrie Canada applicables aux appareils radio exempts de licence. L'exploitation est autorisée aux deux conditions suivantes : (1) l'appareil ne doit pas produire de brouillage, et (2) l'utilisateur de l'appareil doit accepter tout brouillage radioélectrique subi, même si le brouillage est susceptible d'en compromettre le fonctionnement.

FCC ID: WP3MCT340SMA
IC: 1467CMCT340SMA

Reed Switch Positions

Wood		Supports	Iron	
Opening	Closing	Direction	Opening	Closing
>10 mm	<8 mm	X	>10 mm	<9 mm
>25 mm	<21 mm	Y	>12 mm	<10 mm
>30 mm	<25 mm	Z	>12 mm	<10 mm

1. Insert a "quarter" coin in the slot as shown in the drawing and **push downward firmly** into the slot.
2. Twist to remove the cover.
3. Remove the old battery using a 3 mm flat-edged screwdriver.
4. Insert the battery at an angle, as shown in the drawing, while observing battery polarity.

Note: The required battery is CR2032 Lithium 3V, manufactured by VARTA or another UL recognized manufacturer, purchased from a Visonic-approved supplier.

Problem	Remedy
The sensor sends a Low Battery indication.	To ensure continuous proper operation, replace the battery within two weeks of the first Low Battery indication.
Panel does not arm because of an unrecognized sensor malfunction	Consult with your installer or system provider before you disable a zone. Disable the detector zone (see the control panel user manual). Note that disabling a sensor zone lowers the overall security level of your system.

USA/CANADA

Complies with:
USA: CFR 47 part 15, Canada: RSS 210.
ANSI/UL 634, ULC – S306

FCC Compliance Statement

This device has been tested and found to comply with the limits for a Class B digital device, pursuant to Part 15 of the FCC Rules. These limits are designed to provide reasonable protection against harmful interference in residential installations. This equipment generates uses and can radiate radio frequency energy and, if not installed and used in accordance with the instructions, may cause harmful interference to radio and television reception.

However, there is no guarantee that interference will not occur in a particular installation. If this device does cause such interference, which can be verified by turning the device off and on, the user is encouraged to eliminate the interference by one or more of the following measures:

- Re-orient or re-locate the receiving antenna.
- Increase the distance between the device and the receiver.
- Connect the device to an outlet on a circuit different from the one that supplies power to the receiver.
- Consult the dealer or an experienced radio/TV technician.

WARNING! Changes or modifications to this unit not expressly approved by the party responsible for compliance could void the user's authority to operate the equipment.

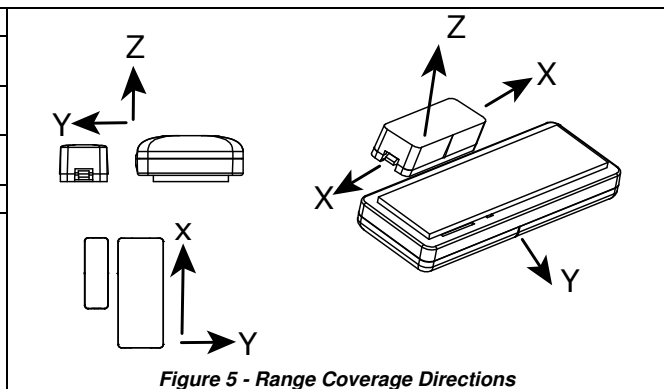

Figure 5 - Range Coverage Directions

9. PRODUCT LIMITATIONS

Visonic Ltd. wireless systems are very reliable and are tested to high standards. However, due to low transmitting power and limited range (required by FCC and other regulatory authorities), there are some limitations to be considered:

A. Receivers may be blocked by radio signals occurring on or near their operating frequencies, regardless of the digital code used.

B. A receiver responds only to one transmitted signal at a time.

C. Wireless devices should be tested regularly to determine whether there are sources of interference and to protect against faults.

The user is cautioned that changes or modifications to the unit, not expressly approved by Visonic Ltd., could void the user's FCC or other authority to operate the equipment.



W.E.E. Product Recycling Declaration

For information regarding the recycling of this product you must contact the company from which you originally purchased it. If you are discarding this product and not returning it for repair then you must ensure that it is returned as identified by your supplier. **This product is not to be thrown away with everyday waste.**
Directive 2002/96/EC Waste Electrical and Electronic Equipment.



EMAIL: info@visonic.com
INTERNET: www.visonic.com

©VISONIC LTD. 2014 MCT-340 SMA D-305291 (Rev 0, 5/14) Please refer to the separate Warranty statement



D-305291

