

# MKP-160

## Touch Screen Keyprox

**Visonic***A Tyco International Company*

### User's Guide

# Table of Contents

1. INTRODUCTION .....	2
2. INSTALLATION .....	3
2.1 Inserting Battery .....	3
2.2 Closing Battery Compartment Cover .....	3
2.3 Wall Mounting Options .....	4
2.4 Enrolling the MKP-160 .....	9
2.5 Configuring the MKP-160 Parameters .....	9
2.6 Enrolling Proximity Tags .....	10
3. USING THE TOUCH SCREEN KEYPROX .....	12
3.1 Arming and Disarming the System .....	12
3.2 Initiating Alarms .....	13
3.3 System Status and Indications .....	13
3.4 Bypassing Zones .....	16
3.5 Controlling Home Automation Devices .....	16
3.6 Other Functions .....	17
APPENDIX A: SPECIFICATIONS .....	18
APPENDIX B: COMPLIANCE WITH STANDARDS .....	19

# 1. INTRODUCTION

MKP-160 is a 2-way wireless PowerCode touch screen keyprox for the PowerMax family control panels. The MKP-160 enables most common everyday user functions:

- Arm and Disarm the alarm system.
- Initiate Emergency, Fire and Panic alarms.
- Control home automation devices.
- Review system status.
- Perform programmable predefined functions.

MKP-160 is operated by proximity tags. When authorization is required the user presents a valid proximity tag to the built-in tag reader.

In addition, the MKP-160 supports panels featuring Partitions. Partitioning allows you to select up to three controllable areas; each partition can be armed and disarmed independently regardless of the status of the other two partitions by the same or different users (see keys marked "7" in the "Quick Reference Guide").

The MKP-160 can be wall-mounted using the supplied bracket or be used as a desktop unit. For compliance with various international standards, the MKP-160 is equipped with two tamper switches that can be defined to detect when the cover of the battery compartment is removed or when the unit is removed from its mounting bracket.

Other features of the MKP-160 include:

- Easy-to-use intuitive graphical touch user interface
- Employees can use their standard RFID access cards with the MKP-160.
- Proximity-tag operated, no need for user to remember codes
- Allows all users' every day actions
- Panel can be installed in hidden location
- 2 per system, suitable for any installation
- Status, Alarm, Memory, Trouble and Ready indications.
- Automatic reporting of low battery.
- Back lighting.
- Audible and visual exit/entry warning beeps
- MKP-160 enables using proximity tags regardless of whether or not the control panel has a proximity tag reader.
- Long battery life expectancy (for typical use).
- Trouble beeps

## 2. INSTALLATION

### 2.1 Inserting Battery

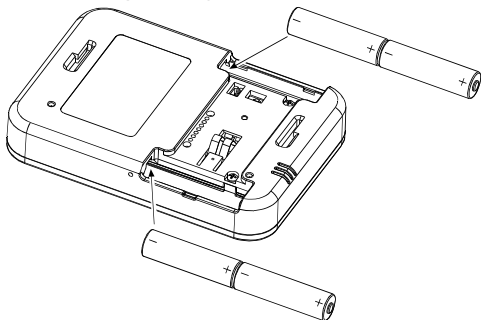

#### CAUTION!

Risk of explosion if battery is replaced by an incorrect type. Dispose of used battery according to manufacturer's instructions.

Figure 1 – Battery Insertion

Insert two 1.5V batteries in each slot while ensuring battery polarity.

### 2.2 Closing Battery Compartment Cover

#### Desktop Installation (Using Battery Cover without Tamper Hole)

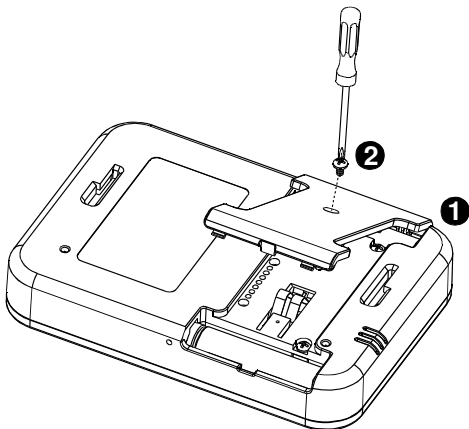

Figure 2 - Battery Cover Mounting (part a)

## Wall-mounted Installation [Via Battery Cover without Tamper Hole (see "A")]

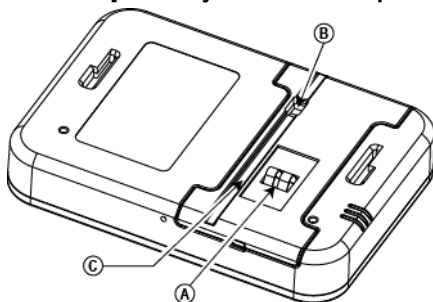

Figure 3 - Battery Cover Mounting (part b)

- A.** Tamper      **B.** DC Power Connection – use supplied cable in addition to batteries  
**C.** Wiring channel for wall installation

*Note: The DC cable is available in specific models*

### 2.3 Wall Mounting Options

The MKP-160 unit mounting options are illustrated in the following drawings.

#### Wall Mounting

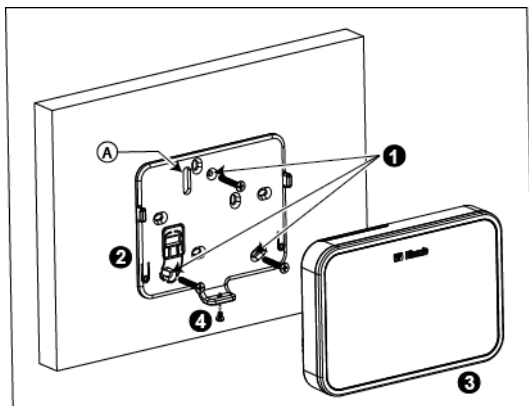
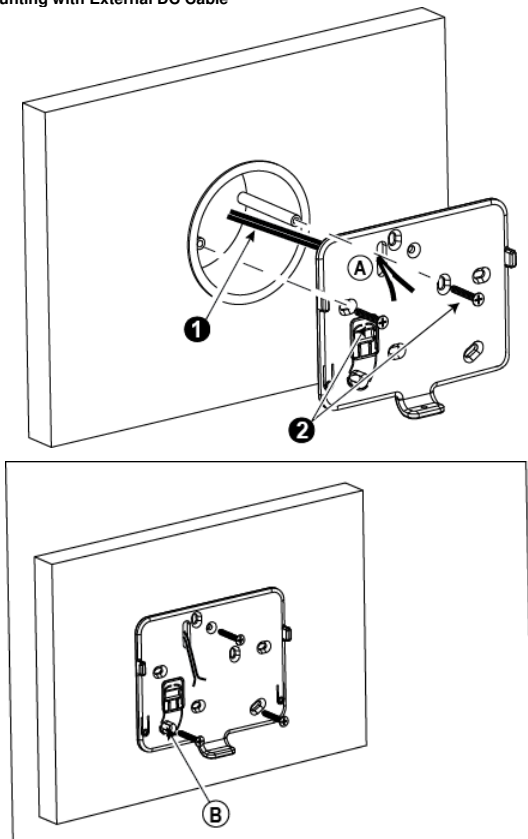

Figure 4 – Wall Mounting

1. Drill 3 mounting holes
  2. Position the bracket and secure with 3 screws
  3. Attach the unit to the bracket
  4. Secure the unit with the screw
- A.** Hole for DC power source cable installed in wall

## Wall Mounting with External DC Cable



1. Hold the power source cable from the wall and thread it through its hole in the bracket
  2. Drill 2 mounting holes and then secure bracket with 2 screws
- A.** Hole for DC power source cable installed in wall      **B.** Hole for tamper



**WARNING!** The power source (optional) must be 5 - 12VDC.

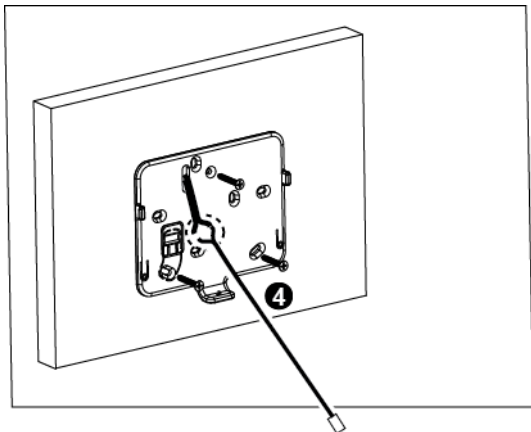
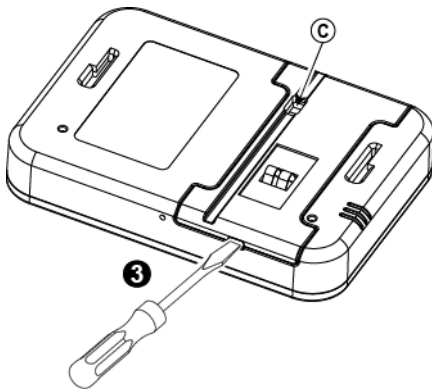

3. Insert screwdriver into slot and lift upward to separate the battery compartment cover from the front cover

4. Connect together the power source cable and the DC cable connector (supplied).

**Note:** The DC cable connector is available in specific models

#### C. DC Power Cable Connection

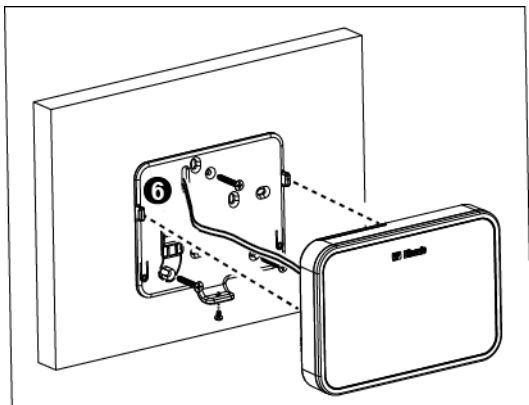
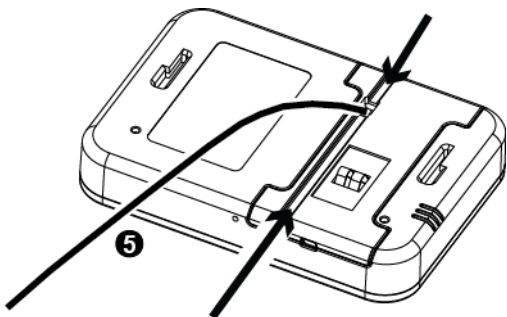

5. Connect the DC cable connector to the DC power connection.

**Note:** You can connect the DC cable directly, as shown in the top drawing, or via one of the wiring inlets indicated by the arrows.

6. Align the bracket pins with their respective slots.



7. Push the MKP-160 unit downward on the bracket

8. Secure the unit with the screw

*Figure 5 – Wall Mounting with External DC Cable*

#### **Desk mount**

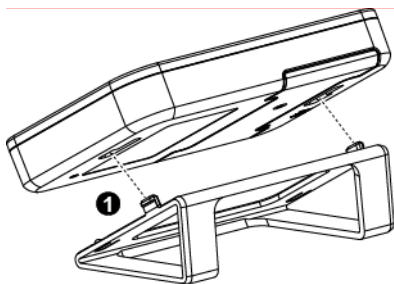





1. Insert the bracket pins into the corresponding slots.

*Figure 6 – Desk mount installation*

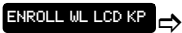
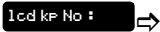

## 2.4 Enrolling the MKP-160

A flowchart of the MKP-160 enrolling procedure is provided below.

Step	Action	LCD Display
1	Enter the Installer menu and select "2:ENROLLING"	
2	Select "ENROLL WL LCD KP" Option See Note	
3	When "1cd kP No : " appears on the control panel display, enter the keyprox number, for example "1cd kP No : 2".	 
4	Enroll the device by pressing the  (AUX) button for about 5 seconds until the LED turns ON and then release the button.	
5	The control panel displays the number of the enrolled device.	
6	Configure the MKP-160 Keyprox	See section 2.5

 means scroll  and select 

**Note:** If the MKP-160 is already enrolled, you can configure the MKP-160 parameters via the "16.DEFINE ARM ST" main menu.

## 2.5 Configuring the MKP-160 Parameters

Enter the  main menu in the PowerMax control panel, choose the number of the touch screen keyprox device to configure and follow the configuration instructions for the MKP-160 touch screen keyprox.

### Option

### Configuration Instructions

#### TAMPER TYPE

Enabling the function will enable a tamper open / close message.

Options settings: **disable** (default) and **enable**.

#### SCREEN SAVER

Enabling the function will turn off the display if no key is pressed for more than several seconds. Tapping on the MKP-160 keyprox will return the device to normal display.

Options settings: **disable (ac)** (default) and **enable**.

#### SHOW AC FAILURE

Enable/disable AC failure indication on the keyprox device.

Options settings: **disable** (default) and **enable**.

**SUPERVISION**

Define whether or not the control panel will monitor supervision messages sent by the keyprox.

Options settings: **disable** and **enable** (default).

**EXIT-ENTRY BEEPS**

Define whether or not the keyprox will sound the exit and entry beeps or whether the keyprox will sound the beeps only when the system is armed AWAY and not when it is armed HOME.

*Note: When the screen saver is active during an exit/entry delay, the MKP-160 device will not sound exit-entry beeps (exit-entry beeps are sounded only through the control panel during this time). If the MKP-160 returns to normal display during the entry/exit delay, it will continue to sound the exit-entry beeps until the next time the screen saver is activated or until the end of the exit/entry delay, whichever first.*

Options settings: **off** (default); **off when home** and **on**.

**SOUNDER VOLUME**

Define the volume level of the sounder.

Options settings: **low**, **mid** (default) and **high**.

**SHOW MEM/TRBL**

Define if Trouble or Memory events in the control panel will be indicated on the LCD keyprox.





Options settings: **enable** (default) and **disable**.

## 2.6 Enrolling Proximity Tags

You can enroll proximity tags in the PowerMax control panel either through the MKP-160 touch screen keyprox, as described below, or through the PowerMax control panel, as described in the corresponding section of the control panel's User or Installer Guide. Each proximity tag corresponds to its User Code. Therefore, be sure that a corresponding User Code is programmed for each enrolled proximity tag (code "0000" is not allowed). For example, "Tag no : 2" must be assigned to User Code 2 and "Tag no : 8" must be assigned to User Code 8. Partition authorization of each proximity tag is identical to that of the corresponding User Code. For example, if User Code 3 is set to Partitions 1 and 3, "Tag no : 3" will also be set to Partitions 1 and 3.







### Enrolling Proximity Tags in the PowerMax Panel through the MKP-160 Keyprox

Step	Action	LCD Display
1	Enter the Installer menu of the control panel and go to <b>"2.ENROLLING"</b>	<b>2.ENROLLING</b> ➡
2	Select <b>"ENROLL PROX TAG"</b> Option	<b>ENROLL PROX TAG</b> ➡
3	Select the Prox Tag number for enrollment	<b>Tag no :</b> ➡ ↓ <b>Tag no : 8</b>

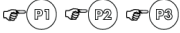
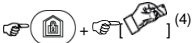
Step	Action	LCD Display
4	<p>When <b>"PRESENT TAG"</b> is displayed, press the AWAY key ( ) on the MKP-160. The AWAY key and the Present Prox Tag key ( ) begin to blink</p>	
5	<p>Present the proximity tag to the MKP-160 within the 5 second timeout period. If the enrollment is successful, the display reads the selected Prox Tag number followed by a box.</p>	

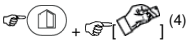
### 3. USING THE TOUCH SCREEN KEYPROX

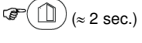
#### 3.1 Arming and Disarming the System



Step	Operation	User Actions	Keyboard & Panel Response
Optional 1	Select a PARTITION <sup>(1)</sup> (if Partition is enabled)	Any combination of 	The selected Partition blinks.
	Arm AWAY <sup>(2)</sup>	 <sup>(4)</sup>	The selected key and the "Present Prox Tag" icon  begin to blink and prompt you to present your Tag (except for Quick Arm).  The keyprox's LED blinks red once to indicate transmission of the arming command to the control panel.  The LED and the buzzer then indicate the control panel's response – see "System Status and Indications" section 3.3.
	Arm HOME <sup>(2)</sup>	 <sup>(4)</sup>	
	Disarm (OFF) <sup>(2)</sup>	 <sup>(4)</sup>	
	Quick arm AWAY <sup>(2) (3)</sup> (If Quick Arm is enabled)	 (≈ 2 sec.)	
	Quick arm HOME <sup>(2) (3)</sup> (If Quick Arm is enabled)	 (≈ 2 sec.)	
Optional 3	INSTANT	(After arming HOME/ AWAY)  <sup>(5) (7)</sup>	
	LATCHKEY	(After arming AWAY)  <sup>(6) (7)</sup>	

#### Notes:

1. If Partition is disabled at the control panel, skip Step 1.
2. If Partition is enabled at the control panel and a partition was not selected in Step 1, Step 2 will activate all of the partitions assigned to the user.
3. The Quick arm functions only if enabled at the control panel.
4. If the action is not completed while the selected arming key is blinking, the desired function will not be executed.
5. Press the INSTANT key within maximum 8 seconds timeout period after completing the previous step. This will delete the entry delay for the current arming session.
  - INSTANT is available only if supported in the PowerMax control panel (refer to the PowerMax Installer Guide).
6. For LATCHKEY activation, press the LATCHKEY key within maximum 8 seconds timeout period after completing the previous step.

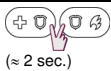

7. **LATCHKEY** is available only if the **LATCHKEY** feature is enabled in the PowerMax control panel (see PowerMax Installer Guide). You can perform the **LATCHKEY** and **INSTANT** functions, one after the other. The order is not important.
- **LATCHKEY** and **INSTANT** functions can be operated only during exit delay.
  - While in **INSTANT** / **LATCHKEY**, the small circle icon on the upper right side of the **INSTANT** / **LATCHKEY** icon lights.

### 3.2 Initiating Alarms

Alarms	Actions	Response	Notes
Emergency alarm	 (≈ 2 sec.)	See section 3.3.	When pressing the Fire or Emergency icons, the MKP-160 starts beeping. After pressing the button for approx. 2 seconds, the MKP-160 sends the command.
Fire alarm	 (≈ 2 sec.)	See section 3.3.	
Panic alarm	 (≈ 2 sec.)	See section 3.3.	When pressing the Fire and Emergency icons together, the MKP-160 starts beeping. After pressing the button for approx. 2 seconds, the MKP-160 sends the Panic command.









### 3.3 System Status and Indications

When executing a command, the MKP-160's LED ("29" in the "Quick Reference Guide") blinks red once to indicate transmission of the command to the control panel. If the operation is **successfully completed**, the green LED lights momentarily and a "**happy tune**" sounds. If the operation **fails or cannot be completed**, for example, when the system is "Not Ready", the red LED lights steadily and a "**sad tune**" sounds.

Buzzer Indication	LED Indication	Panel Response
 Happy ( <b>success</b> ) tune	Momentary GREEN	<b>Success:</b> Operation is successfully completed
 Sad ( <b>failure</b> ) tune	Momentary RED	<b>Fail:</b> Operation failed or invalid key press
None	None	<b>No communication:</b> Control panel does not respond.

## Arming Indications













The table below lists the Arming indication keys and their definition.











Icon/Key Indications	Arming Indication
	ARM AWAY
	ARM HOME
	DISARM
 (followed by)  (followed by) 	EXIT DELAY
 +  the "Present Prox Tag" icon and DISARM key blink simultaneously	ENTRY DELAY

If Partition is enabled, the corresponding (house) icon is displayed according to partition state.

## General Indications

The Ready/Not Ready, Alarm Memory, Trouble and Low Battery indications are provided via the indications in the following table:

Number	Indication <sup>[1]</sup>	What it Means
1		Instructs the user to present the RFID proximity tag in order to initiate a command.
2		Volume control mode.
3		System is NOT READY; one of the zones is not secured. You cannot arm the system before the zone is secured or bypassed.
		System is READY but one or more zones are bypassed.
	No indication	System is READY and all zones are secured.
4	 + 	Bypassed (  ) or Open (  ) Zone number
	 /  + 	Selected PGM or X-10 unit number.
	 + 	Volume level

Number	Indication <sup>[1]</sup>	What it Means
5		PGM/X-10 control mode.
11		System is armed in LATCHKEY mode.
12		Exit beeps are shut off. This mode disables when the exit delay is over. <sup>[2]</sup>
16		System is armed in the INSTANT mode.
22		A message is waiting in the system.
23		The control panel is presently in "INSTALLER MODE" or "USER SETTINGS".
24		Memory / Alarm in partition or system.
25		The partition / system has an active trouble status that needs to be reviewed and cleared. <sup>[3]</sup>
26		AC failure.
27		Communication failure: MKP-160 is out of range of the control panel or did not get an acknowledge signal of a command from the control panel.
28		Indicates that the MKP-160 device's battery is low and must be replaced (see section 2.1).





[1] The key indication is displayed after the first red LED blinks indicating the status request.





[2] Operates only during Exit Delay.

[3] See respective sections in the control panel's User and Installer's Guides.

[4] If there is more than one status indication at a single time, the keys are displayed simultaneously.

## Zone Status Indications

To view the zone numbers of enrolled detectors that are in NOT READY () or BYPASSED state () , repeatedly press the  key. Upon each press of the  key, the next zone number appears on the Zone # display (marked "4" in the "Quick Reference Guide").

To view the zone numbers that are assigned to a Partition, press the desired Partition number ( /  / ) followed by the  key. Upon each press of the  key, the next zone number assigned to the pressed Partition number appears on the Zone # display.



## Notes:

A zone which is **BYPASSED** and **NOT READY** is shown as **BYPASSED** ().

When "00" appears on the Zone # display, this indicates a **NOT READY** state in the alarm system that is not related to any detector, for example, "tamper open" in a keypad or control panel.

If all zones are **READY** and "not bypassed", the  button is disabled.

## 3.4 Bypassing Zones











A zone can be bypassed by pressing the  key until the zone number is shown on the zone # display (marked "4" in the "Quick Reference Guide") followed by the  key.

**Note:** Zone bypassing on the MKP-160 unit can be operated only if Bypass was enabled via the control panel (see PowerMax Installer Guide).

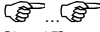
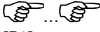
## 3.5 Controlling Home Automation Devices





To operate home automation devices, see the table below.

**Note:** Make sure that the relevant PGM and X-10 outputs are configured correctly; refer to the "OUTPUTS" menu in the control panel's Installer Guide.

Step	X-10 device ON	PGM device ON	X-10 or PGM device OFF	X-10 or PGM device TOGGLE
1	 (~2sec)			
2	 [1 to 15]	 [P0]	 [PGM → P0] or [X-10 → 1 to 15]	 [PGM → P0] or [X-10 → 1 to 15]
3				



The keyprox's LED blinks red once to indicate transmission of the command to the control panel. The LED and the buzzer then indicate the control panel's response – see "System Status and Indications" in section 3.3.

### Note:

- Long press (more than 2 sec.) of the  button initiates the X-10 function and the PGM/X-10 display (marked "4" in the "Quick Reference Guide") will read "01". This number is incremented by 1 upon each press of the  key.
- Short press of the  button initiates the PGM function and the PGM/X-10 display will read "P0" with the  key.



### 3.6 Other Functions

Output Function	Actions	Response
AUX Function		<b>Enrollment:</b> Long key press (more than 5 sec.) until green LED lights and then release key. <b>Back to Factory:</b> Long key press (more than 7 sec.) to reset the MKP-160 device to factory default settings. <b> Cancels current operation:</b> Short key press
Volume control		Changes the volume level upon each key press. Volume level alternates between 1, 2, 3, 0
Mute exit beeps		Mutes the exit beeps; small circle key will appear above the key. Press button again to cancel mute. <b>Note:</b> Operates only per Exit Delay duration. Upon next Exit Delay, the exit beeps will not be muted.

## APPENDIX A: SPECIFICATIONS

<b>Frequency Band (MHz)</b>	Europe and rest of world: 433.92 and 868.95 USA: 315
<b>Communication Protocol</b>	PowerCode
<b>Battery type</b>	Four 1.5V AA Alkaline batteries
<b>Battery Life Expectancy</b>	4 years for supervised mode and 6 years for non-supervised mode.
<b>Low Battery Threshold</b>	3.8 V
<b>Power source (optional)</b>	5-12VDC
<b>Back light</b>	Blue/white or black/white
<b>Operating Temperature</b>	0°C to 55°C (32°F to 131°F)
<b>Dimensions (WxLxD)</b>	150x100x20mm (5-7/8 x 3-7/8 x 13/16 in)
<b>Weight (including battery and bracket)</b>	379 g (13 oz).
<b>Mounting</b>	Wall-mounted or desktop
<b>Color</b>	White, black, or silver
<b>Compliance with Standards</b>	<b>Europe:</b> EN 300220-1, EN 300220-2, EN300330, EN301489, EN60950, EN50131-1, EN50131-3, EN50131-6. <b>USA:</b> CFR 47 part 15 <b>Canada:</b> RSS 210 <b>RFID Tags:</b> ISO-18000-2 (125 kHz)
<b>EN 50131-1 Security Grade</b>	Grade 2
<b>EN 50131-1 Environmental Class</b>	Class 2

## APPENDIX B: COMPLIANCE WITH STANDARDS

### Compliance with Standards

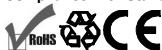

**Europe:** EN 300220-1, EN 300220-2, EN300330, EN301489, EN60950, EN50131-1, EN50131-3, EN50131-6. The MKP-160 is compatible with the RTTE requirements - Directive 1999/5/EC of the European Parliament and of the Council of 9 March 1999 and EN50131-1 Grade 2 Class II.

EN 50131-1 Security Grade, Grade 2; EN 50131-1 Environmental Class, Class 2

**USA:** CFR 47 part 15

**Canada:** RSS 210

**RFID Tags:** ISO-18000-2 (125 kHz)

This device complies with FCC Rules Part 15 and Industry Canada license-exempt RSS standard(s). Operation is subject to the following two conditions: (1) this device may not cause interference, and (2) this device must accept any interference, including interference that may cause undesired operation of the device.

Le présent appareil est conforme aux CNR d'Industrie Canada applicables aux appareils radio exempts de licence. L'exploitation est autorisée aux deux conditions suivantes : (1) l'appareil ne doit pas produire de brouillage, et (2) l'utilisateur de l'appareil doit accepter tout brouillage radioélectrique subi, même si le brouillage est susceptible d'en compromettre le fonctionnement.

**WARNING!** To comply with FCC and IC RF exposure compliance requirements, the mobile version of this device should be located at a distance of at least 20 cm from all persons during normal operation. The antennas used for this product must not be co-located or operated in conjunction with any other antenna or transmitter.

*The portable device version complies with FCC and IC RF radiation exposure limits set forth for an uncontrolled environment.*

The digital circuit of this device has been tested and found to comply with the limits for a Class B digital device, pursuant to Part 15 of the FCC Rules. These limits are designed to provide reasonable protection against harmful interference in residential installations. This equipment generates, uses, and can radiate radio frequency energy and, if not installed and used in accordance with the instructions, may cause harmful interference to radio and television reception. However, there is no guarantee that interference will not occur in a particular installation. If this device does cause such interference, which can be verified by turning the device off and on, the user is encouraged to eliminate the interference by one or more of the following measures:

- Re-orient or re-locate the receiving antenna.
- Increase the distance between the device and the receiver.
- Connect the device to an outlet on a circuit different from the one which supplies power to the receiver.
- Consult the dealer or an experienced radio/TV technician.

Changes or modifications not expressly approved by Visonic Ltd. could void the user's authority to operate the equipment.



#### W.E.E. Product Recycling Declaration

For information regarding the recycling of this product you must contact the company from which you originally purchased it. If you are discarding this product and not returning it for repair then you must ensure that it is returned as identified by your supplier. This product is not to be thrown away with everyday waste.

Directive 2002/96/EC Waste Electrical and Electronic Equipment.

The technical documentation as required by the European Conformity Assessment procedure is kept at:

**UNIT 6 MADINGLEY COURT CHIPPENHAM DRIVE KINGSTON MILTON KEYNES MK10 0BZ.**

**Tel.: +44(0)845 0755800 Fax: +44(0)845 0755801 Product Support: +44(0)845 755802**

## WARRANTY

Visonic Limited (the "Manufacturer") warrants this product only (the "Product") to the original purchaser only (the "Purchaser") against defective workmanship and materials under normal use of the Product for a period of twelve (12) months from the date of shipment by the Manufacturer.

This Warranty is absolutely conditional upon the Product having been properly installed, maintained and operated under conditions of normal use in accordance with the Manufacturers recommended installation and operation instructions. Products which have become defective for any other reason, according to the Manufacturers discretion, such as improper installation, failure to follow recommended installation and operational instructions, neglect, willful damage, misuse or vandalism, accidental damage, alteration or tampering, or repair by anyone other than the manufacturer, are not covered by this Warranty.

The Manufacturer does not represent that this Product may not be compromised and/or circumvented or that the Product will prevent any death and/or personal injury and/or damage to property resulting from burglary, robbery, fire or otherwise, or that the Product will in all cases provide adequate warning or protection. The Product, properly installed and maintained, only reduces the risk of such events without warning and it is not a guarantee or insurance that such events will not occur.

**THIS WARRANTY IS EXCLUSIVE AND EXPRESSLY IN LIEU OF ALL OTHER WARRANTIES, OBLIGATIONS OR LIABILITIES, WHETHER WRITTEN, ORAL, EXPRESS OR IMPLIED, INCLUDING ANY WARRANTY OF MERCHANTABILITY OR FITNESS FOR A PARTICULAR PURPOSE, OR OTHERWISE. IN NO CASE SHALL THE MANUFACTURER BE LIABLE TO ANYONE FOR ANY CONSEQUENTIAL OR INCIDENTAL DAMAGES FOR BREACH OF THIS WARRANTY OR ANY OTHER WARRANTIES WHATSOEVER, AS AFORESAID.**

The Manufacturers obligations under this Warranty are limited solely to repair and/or replace at the Manufacturer's discretion any Product or part thereof that may prove defective. Any repair and/or replacement shall not extend the original Warranty period. The Manufacturer shall not be responsible for dismantling and/or reinstallation costs. To exercise this Warranty the Product must be returned to the Manufacturer freight pre-paid and insured. All freight and insurance costs are the responsibility of the Purchaser and are not included in this Warranty.

*This warranty shall not be modified, varied or extended, and the Manufacturer does not authorize any person to act on its behalf in the modification, variation or extension of this warranty. This warranty shall apply to the Product only. All products, accessories or attachments of others used in conjunction with the Product, including batteries, shall be covered solely by their own warranty, if any.*

**THE MANUFACTURER SHALL IN NO EVENT BE LIABLE FOR ANY SPECIAL, INDIRECT, INCIDENTAL, CONSEQUENTIAL OR PUNITIVE DAMAGES OR FOR LOSS, DAMAGE, OR EXPENSE, INCLUDING LOSS OF USE, PROFITS, REVENUE, OR GOODWILL, DIRECTLY OR INDIRECTLY ARISING FROM PURCHASER'S USE OR INABILITY TO USE THE PRODUCT, OR FOR LOSS OR DESTRUCTION OF OTHER PROPERTY OR FROM ANY OTHER CAUSE, EVEN IF MANUFACTURER HAS BEEN ADVISED OF THE POSSIBILITY OF SUCH DAMAGE.**

**THE MANUFACTURER SHALL HAVE NO LIABILITY FOR ANY DEATH, PERSONAL AND/OR BODILY INJURY AND/OR DAMAGE TO PROPERTY OR OTHER LOSS WHETHER DIRECT, INDIRECT, INCIDENTAL, CONSEQUENTIAL OR OTHERWISE, BASED ON A CLAIM THAT THE PRODUCT FAILED TO FUNCTION.**

However, if the Manufacturer is held liable, whether directly or indirectly, for any loss or damage arising under this limited warranty, **THE MANUFACTURER'S MAXIMUM LIABILITY (IF ANY) SHALL NOT IN ANY CASE EXCEED THE PURCHASE PRICE OF THE PRODUCT**, which shall be fixed as liquidated damages and not as a penalty, and shall be the complete and exclusive remedy against the Manufacturer.

When accepting the delivery of the Product, the Purchaser agrees to the said conditions of sale and warranty and he recognizes having been informed of.

Some jurisdictions do not allow the exclusion or limitation of incidental or consequential damages, so these limitations may not apply under certain circumstances.

The Manufacturer shall be under no liability whatsoever arising out of the corruption and/or malfunctioning of any telecommunication or electronic equipment or any programs.

The Manufacturer shall not be liable for any damage or loss whatsoever, whether directly, indirectly, incidentally, consequentially or otherwise, caused by the malfunction of the Product due to products, accessories, or attachments of others, including batteries, used in conjunction with the Products. This Warranty is exclusive to the original Purchaser and is not assignable.

This Warranty is in addition to and does not affect your legal rights. Any provision in this warranty which is contrary to the Law in the state or country where the Product is supplied shall not apply.

**Warning:** The user must follow the Manufacturer's installation and operational instructions including testing the Product and its whole system at least once a week and to take all necessary precautions for his/her safety and the protection of his/her property.

1/08