

NEXT CAM PG2, NEXT CAM-K9 PG2

Wireless, PowerG, PIR / Pet Immune Detectors with
Integrated Camera



Installation Instructions

1. INTRODUCTION

The Next CAM PG2 is a 2-way, microprocessor-controlled, wireless digital PIR detector with integrated camera and microphone for alarm verification.

The PIR detector's features are as follows:

- Combined Fresnel and cylindrical optics, up to 12 meters (40 ft).
- The Next CAM PG2 includes wall creep zone protection.
- For pet immune version - Target Specific Imaging™ (TSI) technology is used for distinction between human beings and pets weighing up to 38 kg (85lb).
- Includes a fully supervised PowerG transceiver.
- The advanced **True Motion Recognition™** algorithm (patented) allows distinguishing between the true motion of an intruder and any other disturbances which may cause false alarms.
- No vertical adjustment is needed.
- Motion event counter determines whether 1 or 2 consecutive motion events will trigger an alarm.
- Automatic termination of walk-test after 15 minutes.
- Microprocessor-controlled temperature compensation.
- Sealed chamber protects the optical system.
- Front cover and back tamper, for improved tamper protection.
- White light protection.
- Battery compartment

The camera's features are as follows:

- Day and night CMOS camera, with IR illumination. This allows taking pictures in full darkness without letting the intruder know.
- Camera range: 12 m (40ft). With IR illumination 10m (33 ft).
- Picture format and resolution: JPEG, QVGA (320x240 pixels).
- Frame rate: up to 3 fps (for user).
- Audio format: ADPCM, 4bit / 2bit.

• Camera operation modes:

- Post alarm – pictures are taken after detection by detector.
- On demand – pictures are taken after a command from the monitoring station.

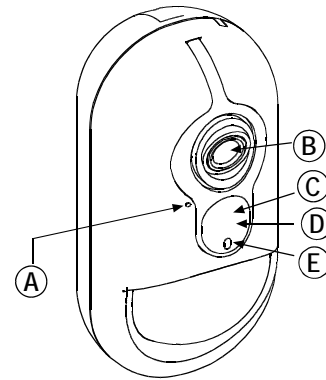

- A. Microphone
- B. Camera lens
- C. IR LED
- D. Light sensor
- E. LEDs

Fig. 1. External View

2. SPECIFICATIONS

GENERAL

Detector Type: Dual element low-noise pyroelectric sensor

Lens Data: No. of Curtain Beams / curtains:

Next CAM PG2: 18 far, 18 mid, 10 close.

Next CAM-K9 PG2: 18 far, 18 mid, 18 close.

Max. Coverage: 12 x 12 m, (40 x 40 ft) / 90°

Pet Immunity (Next CAM-K9 PG2 only): Up to 38 kg (85 lb).

ELECTRICAL

Internal Battery: 6V Lithium battery (two CR-123A 3V batteries or two CR17450 3V batteries, in series) or equivalent.

Note: For UL installations use Panasonic, Sanyo, GP or Varta only. Use only the above battery. Dispose of used battery according to the manufacturer's instructions.

Nominal Battery Capacity: 6V 1450 mA/h (2xCR123A), 2200 mA/h (2xCR17450)

Battery Life (for typical use): 3 or 5 years depending on battery pack type (and camera version)

Optional MAINS supply: Additional to batteries, 7.5 V DC.

Power Supply: Type C

FUNCTIONAL

True Motion Event Verification: 2 remote selections - 1 (OFF) or 2 (ON) motion events

Alarm Period: 2 seconds

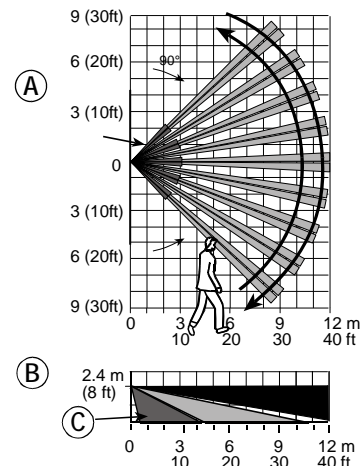

- A. TOP VIEW
- B. SIDE VIEW
- C. Next CAM PG2: 0.5-4m, Next CAM -K9 PG2: 2-4m

Fig. 2. Coverage Pattern & Walk-test

WIRELESS

Frequency Band (MHz): Europe: 433, 868, USA: 915

Modulation: GFSK

Antenna: Built-in helical antenna

Communication Protocol: PowerG

Supervision: Signaling at 4-min. intervals

Tamper Alert: Reported when a tamper event occurs and in any subsequent message, until the tamper switch is restored

MOUNTING

Height: 1.8 - 2.4 m (6 - 8 ft). For Next CAM-K9 PG2, the recommended height is up to 2.1 m (7 ft)

Installation Options: Surface or corner

ACCESSORIES

BR-1: Surface mounted swivel bracket, adjustable 30° down and 45° left/45° right.

BR-2: BR-1 with a corner adapter

BR-3: BR-1 with a ceiling adapter

ENVIRONMENTAL

RFI Protection: >20 V/m up to 2000 MHz, excluding inband frequencies

Operating Temperatures: -10°C to 50°C (14°F to 122°F) indoor

Storage Temperatures: -20°C to 60°C (-4°F to 140°F).

Humidity: Average relative humidity of approximate 75% non-condensing. For 30 days per year relative humidity may vary between 85 % and 95 % non-condensing.

Compliance with Standards:

USA: Designed to meet FCC Part 15

Europe: Directive 1999/5/EC of the European Parliament. EN 50131-1 Grade 2 Class II. EN 50131-2-2, EN 50131-6

PHYSICAL

Size (H x W x D): 125 x 63 x 60 mm (4-15/16 x 2-1/2 x 2-3/8").

Weight (with battery): 200 g (7 oz).

Color: White

PATENTS

U.S. Patents 5,693,943 • 6,211,522 • D445,709 (another patent pending)

3. ENROLLMENT

Refer to the PowerMaster-10 Installer Guide for the device enrollment procedure.









































4. MODIFY DEVICE SETTINGS

This section describes how to configure the parameters of the PIR detector from the PowerMaster-10 control panel.

To Modify the PIR Detector Device Settings

Refer to the PowerMaster-10 Installer Guide and perform the procedure for Adding A Wireless Device (section 4.5.2), or, Modifying a Device (section 4.5.5). Then continue below to modify the device settings.

- | | DEV SETTINGS | |
|-----|--------------|--|
| 1. | | Here you determine whether or not the alarm LED indication will be activated. |
| 2. | | |
| 3. | | Select between "LED ON" and "LED OFF". |
| 4. | | |
| 5. | | Here you determine whether an alarm will be activated upon continued motion (low sensitivity) or upon a single alarm event (high sensitivity). |
| 6. | | |
| 7. | | Select between "LOW sensitive" and "HIGH sensitive". |
| 8. | | |
| 9. | | Here you set the activity time during disarm. |
| 10. | | |
| 11. | | Select between "NOT Active", "YES - no delay", "YES + 5s delay", "YES + 15s delay", "YES + 30s delay", "YES + 1m delay", "YES + 2m delay", "YES + 5m delay", "YES + 10m delay", "YES + 20m delay" and "YES + 60m delay". |
| 12. | | |
| 13. | | Here you determine whether or not to report power failure and restore. |

14. 

15.  Select between "NOT connected" and "Connected to AC".
16. 

17. 
 Here you determine whether the image will be in black & white or color.
18. 

19.  Select between "Black & White" and "Color".
20. 

21. 
 Here you set the pixel quality of the image. Select 160 x 120 for lower quality or 320 x 240 for higher quality.
22. 

23.  Select between "Resol. 160 x 120" and "Resol. 320 x 240".
24. 

25. 
 Here you set the brightness of the image.
26. 

27.  Select between "-3", "-2", "-1", "Normal", "+1", "+2" and "+3".
28. 

29. 
 Here you set the contrast of the image.
30. 

31.  Select between "-3", "-2", "-1", "Normal", "+1", "+2" and "+3".
32. 

33. 
 Here you determine whether or not to activate the microphone.
34. 

35.  Select between "Enable" and "Disable".
36. 

When exiting "ZONES / DEVICES" menu, the PowerMaster-10 system displays the number of devices that need to be updated, as follows: DEV UPDATING NNN.

For detailed instructions on Adding Devices, Deleting Devices, Replacing Devices and Defining Defaults see the PowerMaster-10 Installer Guide.

5. LOCAL DIAGNOSTICS TEST

- Separate the base from the cover (see Fig. 5).
- Put back the cover to return the tamper switch to its normal (undisturbed) position, and then secure the front cover to the base with the case closure screw.
- Walk-test the coverage area - see fig. 2. Walk across the far end of coverage pattern in both directions, The red LED lights each time your motion is detected followed by 3 LED blinks. The following table indicates received signal strength indication.

LED response	Reception
Green LED blinks	Strong
Orange LED blinks	Good
Red LED blinks	Poor
No blinks	No communication

IMPORTANT! Reliable reception must be assured. Therefore, "poor" signal strength is not acceptable. If you receive a "poor" signal from the detector, re-locate it and re-test until a "good" or "strong" signal strength is received.

Note: For detailed Diagnostics Test instructions refer to PowerMaster-10 Installer Guide.

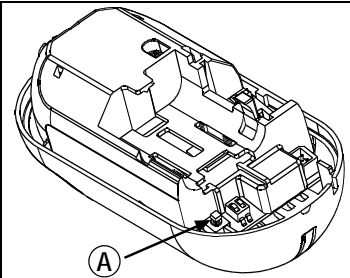

A. Enroll button
Figure 3. Device enroll button

6. INSTALLATION

6.1 General Guidance (see fig. 4)

- | | |
|---------------------------------|--|
| 1. Keep away from heat sources. | 5. Keep wiring away from power cables. |
| 2. Do not expose to air drafts. | 6. Do not install behind partitions. |
| 3. Do not install outdoors. | 7. Mount on solid stable surface. |
| 4. Avoid direct sunshine. | |

WARNING! To comply with FCC RF exposure compliance requirements, the PIR detector should be located at a distance of at least 20 cm from all persons during normal operation. The antennas used for this product must not be co-located or operated in conjunction with any other antenna or transmitter

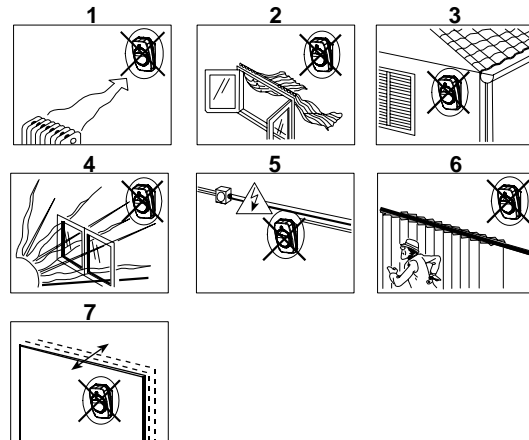
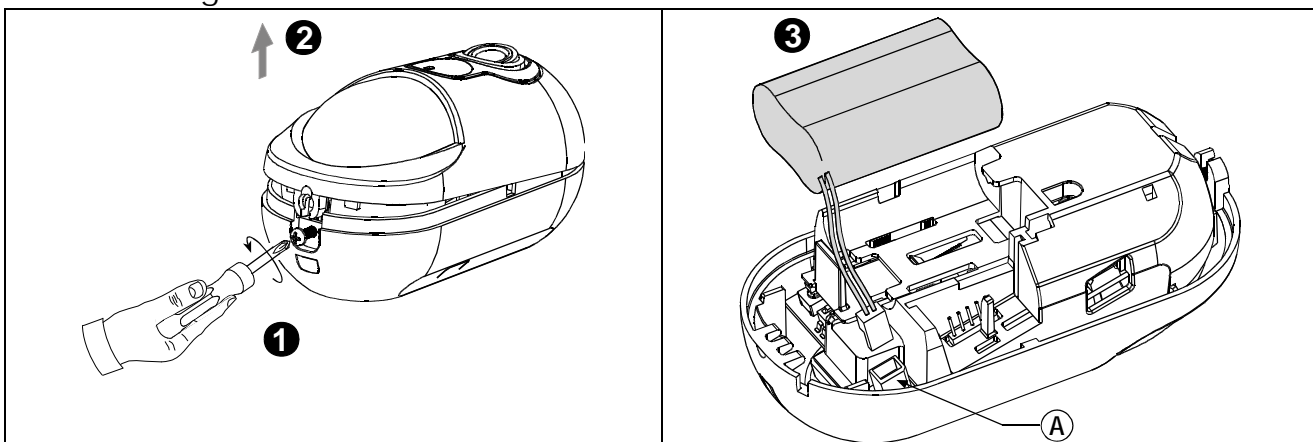

Figure 4. General Guidelines



Important! The Next CAM-K9 PG2 detector is immune to 38 kg (85 lb) animals moving on the floor or climbing on furniture as long as the activity takes place below 1 m (3 ft). Above the 1 m (3 ft) height limit, the detector is immune to 19 kg (42 lb) pets, but the pet immunity will decrease as the pet gets closer to the detector. It is therefore recommended to select a mounting location that minimizes potential close proximity of animals.

6.2 Mounting



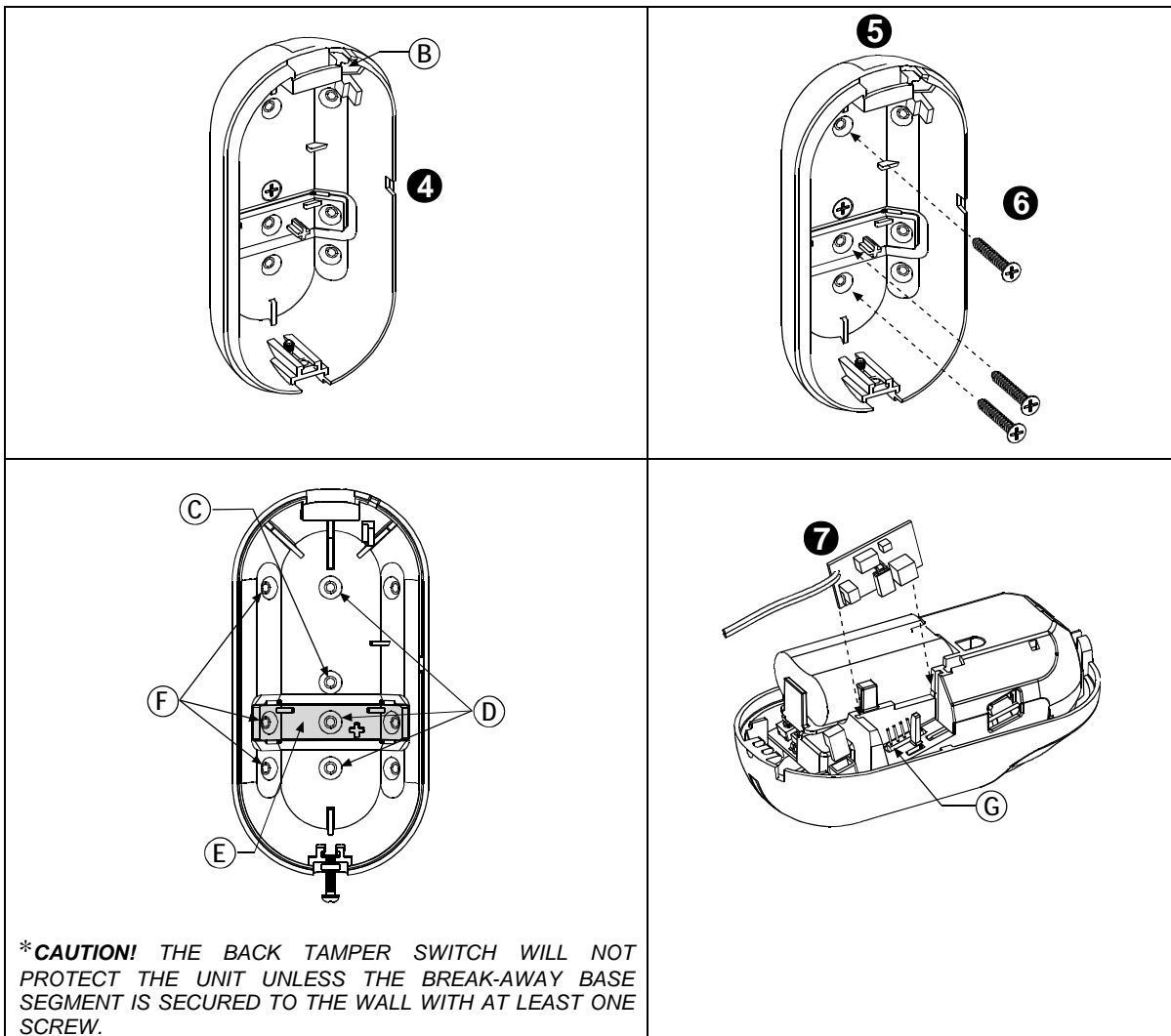

Figure 5a. Mounting on Wall

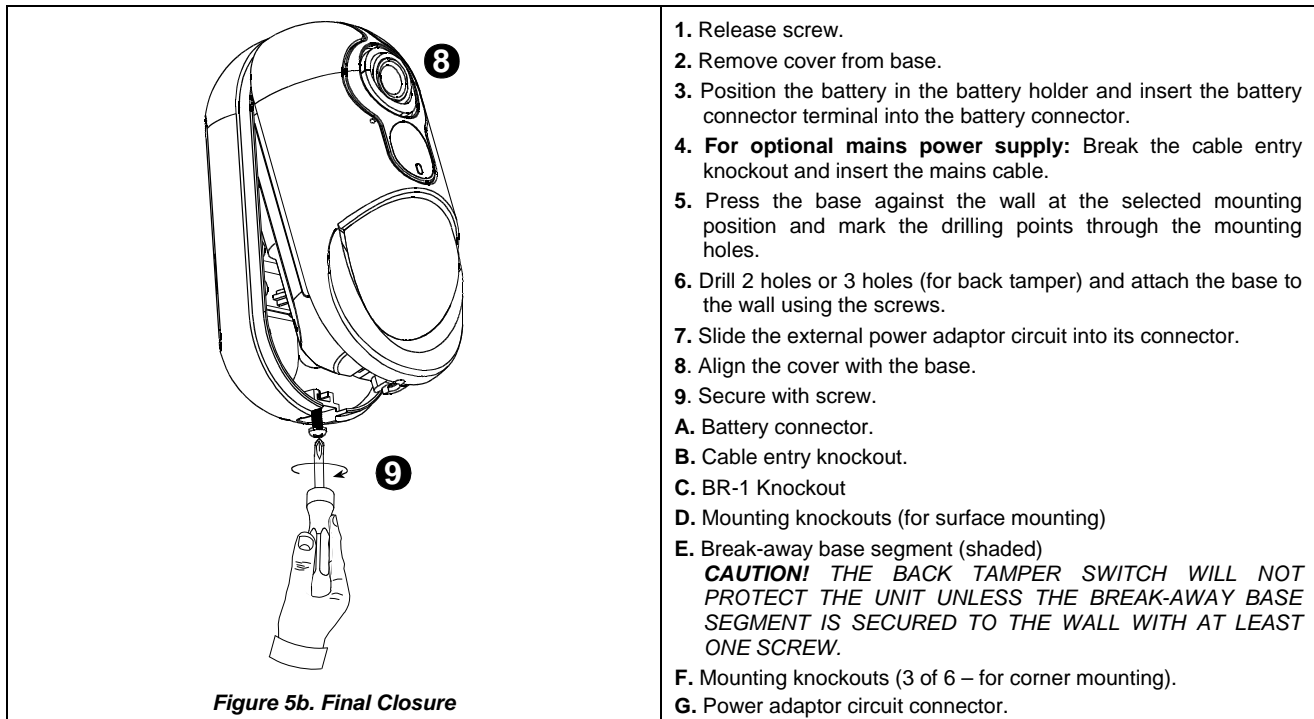

Figure 5b. Final Closure

7. SPECIAL COMMENTS

Even the most sophisticated detectors can sometimes be defeated or may fail to warn due to: DC power failure / improper connection, malicious masking of the lens, tampering with the optical system, decreased sensitivity in ambient temperatures close to that of the human body and unexpected failure of a component part.

The above list includes the most common reasons for failure to detect intrusion, but is by no means comprehensive. It is therefore recommended that the detector and the entire alarm system be checked weekly, to ensure proper performance.

An alarm system should not be regarded as a substitute for insurance. Home and property owners or renters should be prudent enough to continue insuring their lives and property, even though they are protected by an alarm system.

This device has been tested and found to comply with the limits for a Class B digital device, pursuant to Part 15 of the FCC Rules. These limits are designed to provide reasonable protection against harmful interference in residential installations. This equipment generates uses and can radiate radio frequency energy and, if not installed and used in accordance with the instructions, may cause harmful interference to radio and television reception.

However, there is no guarantee that interference will not occur in a

particular installation. If this device does cause such interference, which can be verified by turning the device off and on, the user is encouraged to eliminate the interference by one or more of the following measures:

- Re-orient or re-locate the receiving antenna.
- Increase the distance between the device and the receiver.
- Connect the device to an outlet on a circuit different from the one that supplies power to the receiver.
- Consult the dealer or an experienced radio/TV technician.

WARNING! Changes or modifications to this unit not expressly approved by the party responsible for compliance could void the user's authority to operate the equipment.

This device complies with FCC Rules Part 15. Operation is subject to two conditions: (1) This device may not cause harmful interference, and (2) this device must accept any interference that may be received or that may cause undesired operation.

WARRANTY

Visonic Limited (the "Manufacturer") warrants this product only (the "Product") to the original purchaser only (the "Purchaser") against defective workmanship and materials under normal use of the Product for a period of twelve (12) months from the date of shipment by the Manufacturer.

This Warranty is absolutely conditional upon the Product having been properly installed, maintained and operated under conditions of normal use in accordance with the Manufacturers recommended installation and operation instructions. Products which have become defective for any other reason, according to the Manufacturers discretion, such as improper installation, failure to follow recommended installation and operational instructions, neglect, willful damage, misuse or vandalism, accidental damage, alteration or tampering, or repair by anyone other than the manufacturer, are not covered by this Warranty.

The Manufacturer does not represent that this Product may not be compromised and/or circumvented or that the Product will prevent any death and/or personal injury and/or damage to property resulting from burglary, robbery, fire or otherwise, or that the Product will in all cases provide adequate warning or protection. The Product, properly installed and maintained, only reduces the risk of such events without warning and it is not a guarantee or insurance that such events will not occur.

THIS WARRANTY IS EXCLUSIVE AND EXPRESSLY IN LIEU OF ALL OTHER WARRANTIES, OBLIGATIONS OR LIABILITIES, WHETHER WRITTEN, ORAL, EXPRESS OR IMPLIED, INCLUDING ANY WARRANTY OF MERCHANTABILITY OR FITNESS FOR A PARTICULAR PURPOSE, OR OTHERWISE. IN NO CASE SHALL THE MANUFACTURER BE LIABLE TO ANYONE FOR ANY CONSEQUENTIAL OR INCIDENTAL DAMAGES FOR BREACH OF THIS WARRANTY OR ANY OTHER WARRANTIES WHATSOEVER, AS AFORESAID.

THE MANUFACTURER SHALL IN NO EVENT BE LIABLE FOR ANY SPECIAL, INDIRECT, INCIDENTAL, CONSEQUENTIAL OR PUNITIVE DAMAGES OR FOR LOSS, DAMAGE, OR EXPENSE, INCLUDING LOSS OF USE, PROFITS, REVENUE, OR GOODWILL, DIRECTLY OR INDIRECTLY ARISING FROM PURCHASER'S USE OR INABILITY TO USE THE PRODUCT, OR FOR LOSS OR DESTRUCTION OF OTHER PROPERTY OR FROM ANY OTHER CAUSE, EVEN IF MANUFACTURER HAS BEEN ADVISED OF THE POSSIBILITY OF SUCH DAMAGE.

THE MANUFACTURER SHALL HAVE NO LIABILITY FOR ANY DEATH, PERSONAL AND/OR BODILY INJURY AND/OR DAMAGE TO PROPERTY OR OTHER LOSS WHETHER DIRECT, INDIRECT, INCIDENTAL, CONSEQUENTIAL OR OTHERWISE, BASED ON A CLAIM THAT THE PRODUCT FAILED TO FUNCTION.

However, if the Manufacturer is held liable, whether directly or indirectly, for any loss or damage arising under this limited warranty, **THE MANUFACTURER'S MAXIMUM LIABILITY (IF ANY) SHALL NOT IN ANY CASE EXCEED THE PURCHASE PRICE OF THE PRODUCT**, which shall be fixed as liquidated damages and not as a penalty, and shall be the complete and exclusive remedy against the Manufacturer.

When accepting the delivery of the Product, the Purchaser agrees to the said conditions of sale and warranty and he recognizes having been informed of.

Some jurisdictions do not allow the exclusion or limitation of incidental or consequential damages, so these limitations may not apply under certain circumstances.

The Manufacturer shall be under no liability whatsoever arising out of the corruption and/or malfunctioning of any telecommunication or electronic equipment or any programs.

The Manufacturers' obligations under this Warranty are limited solely to repair and/or replace at the Manufacturer's discretion any Product or part thereof that may prove defective. Any repair and/or replacement shall not extend the original Warranty period. The Manufacturer shall not be responsible for dismantling and/or reinstallation costs. To exercise this Warranty the Product must be returned to the Manufacturer freight pre-paid and insured. All freight and insurance costs are the responsibility of the Purchaser and are not included in this Warranty.

This warranty shall not be modified, varied or extended, and the Manufacturer does not authorize any person to act on its behalf in the modification, variation or extension of this warranty. This warranty shall apply to the Product only. All products, accessories or attachments of others used in conjunction with the Product, including batteries, shall be covered solely by their own warranty, if any. The Manufacturer shall not be liable for any damage or loss whatsoever, whether directly, indirectly, incidentally, consequentially or otherwise, caused by the malfunction of the Product due to products, accessories, or attachments of others, including batteries, used in conjunction with the Products. This Warranty is exclusive to the original Purchaser and is not assignable.

This Warranty is in addition to and does not affect your legal rights. Any provision in this warranty which is contrary to the Law in the state or country where the Product is supplied shall not apply.

Warning: The user must follow the Manufacturer's installation and operational instructions including testing the Product and its whole system at least once a week and to take all necessary precautions for his/her safety and the protection of his/her property.

1/08



W.E.E. Product Recycling Declaration

For information regarding the recycling of this product you must contact the company from which you originally purchased it. If you are discarding this product and not returning it for repair then you must ensure that it is returned as identified by your supplier. This product is not to be thrown away with everyday waste.
Directive 2002/96/EC Waste Electrical and Electronic Equipment.



VISONIC LTD. (ISRAEL): P.O.B 22020 TEL-AVIV 61220 ISRAEL. PHONE: (972-3) 645-6789, FAX: (972-3) 645-6788

VISONIC INC. (U.S.A.): 65 WEST DUDLEY TOWN ROAD, BLOOMFIELD CT. 06002-1376. PHONE: (860) 243-0833, (800) 223-0020.

FAX: (860) 242-8094

VISONIC LTD. (UK): UNIT 6 MADINGLEY COURT CHIPPENHAM DRIVE KINGSTON MILTON KEYNES MK10 0BZ. TEL: (0870) 7300800

FAX: (0870) 7300801. TEL: (0870) 7300800 FAX: (0870) 7300801 **PRODUCT SUPPORT: (0870) 7300830**

VISONIC GmbH (D-A-CH): KIRCHFELDSTR. 118, D-40215 DÜSSELDORF, TEL.: +49 (0)211 600696-0, FAX: +49 (0)211 600696-19

VISONIC IBERICA: ISLA DE PALMA, 32 NAVE 7, POLIGONO INDUSTRIAL NORTE, 28700 SAN SEBASTIÁN DE LOS REYES, (MADRID), ESPAÑA.

TEL (34) 91659-3120, FAX (34) 91663-8468. www.visonic-iberica.es

INTERNET: www.visonic.com

©VISONIC LTD. 2010 NEXT CAM PG2, NEXT CAM-K9 PG2 D-302893 (preparation for revision 1, 10/10)



MADE IN ISRAEL