

PowerMaster 360

Version 18

Installer's Guide

Table of Contents

1. INTRODUCTION	3		
1.1 System Features	3		
2. CHOOSING THE INSTALLATION LOCATION ..	6		
3. INSTALLATION	7		
3.1 Connections and LED Indications	7		
3.2 Inserting the Battery	8		
3.3 PowerManage 360 Connections	9		
3.4 GSM Connection and Configuration	10		
3.5 SIM Card Insertion	10		
3.6 PowerMaster 360 Prerequisites	10		
3.7 Enrolling / Deleting a Z-Wave Device	10		
3.8 Panel Reset	11		
3.9 Factory Default Restore	11		
4. PROGRAMMING	12		
4.1 General Guidance	12		
4.1.1 Navigation	12		
4.1.2 Feedback Sounds	14		
4.2 Entering the "Installer Mode" and Selecting a Menu Option	14		
4.2.1 Entering the "Installer Mode" if "User Permit" is enabled.....	14		
4.2.2 Selecting options.....	15		
4.2.3 Exiting the Installer Mode.....	15		
4.3 Setting Installer Codes	15		
4.3.1 Identical Installer and Master Installer Codes	16		
4.4 Zones / Devices	16		
4.4.1 General Guidance & Zones/Devices Menu Options	16		
4.4.2 Adding New Wireless Devices	17		
4.4.3 Deleting a Device	21		
4.4.4 Modifying or Reviewing a Device	21		
4.4.5 Replacing a Device	22		
4.4.6 Configuring Soak Test Mode.....	22		
4.4.7 Defining Configuration Defaults for "Device Settings"	23		
4.4.8 Updating Devices after Exiting Installer Mode.....	23		
4.5 Control Panel	24		
		4.5.1 General Guidance – "Control Panel" Flow-Chart & Menu Options	24
		4.5.2 Configuring Arming/Disarming and Exit/Entry Procedures.....	25
		4.5.3 Configuring Zones Functionality	26
		4.5.4 Configuring Alarms & Troubles.....	27
		4.5.5 Configuring Sirens Functionality	28
		4.5.6 Configuring Audible & Visual User Interface	28
		4.5.7 Configuring Jamming and Supervision (Missing device)	29
		4.5.8 Configuring Miscellaneous Features...30	
		4.6 Communication	31
		4.6.1 General Guidance – "Communication" Flow-Chart & Menu Options	31
		4.6.2 Configuring GSM-GPRS (IP) - SMS Cellular Connection	32
		4.6.3 Configuring Events Reporting to Monitoring Stations.....	33
		4.6.4 Configuring Events Reporting to Private Users.....	36
		4.6.5 Configuring Motion Cameras for Visual Alarm Verification	36
		4.6.6 Configuring Upload / Download Remote Programming Access Permission.....	37
		4.6.7 Broadband.....	38
		4.7 Custom Names	39
		4.7.1 Custom Zone Names.....	39
		4.8 Diagnostics	40
		4.8.1 General Guidance – "Diagnostics" Flow-Chart & Menu Options	40
		4.8.2 Testing Wireless Devices	40
		4.8.3 Testing the GSM module	42
		4.8.4 Testing the SIM Number.....	42
		4.8.5 Testing the Broadband/PowerLink Module	43
		4.9 User Settings	43
		4.10 Factory Default	44
		4.11 Serial Number	44
		4.12 Partitioning	44

4.12.1 General Guidance – "Partitioning" Menu.....	44	APPENDIX C. User Mobile Application with PowerMaster 360.....	75
4.12.2 Enabling / Disabling Partitions.....	44	C1. Security Only Via PowerManage.....	75
4.13 Operation Mode.....	45	C2. Security and Smart Home Via 3rd Party	75
4.13.1 General Guidance – "Operation Mode" Menu.....	45	APPENDIX D. Specifications	76
4.13.2 Select setting	45	D1. Functional.....	76
4.13.3 BS8243 Setup.....	45	D2. Wireless	76
4.13.4 DD243 Setup	46	D3. Electrical	77
4.13.5 CP01 Setup.....	48	D4. Communication.....	77
4.13.6 OTHERS Setup.....	49	D5. Physical Properties.....	77
5. PERIODIC TEST	51	D6. Peripherals and Accessory Devices	77
5.1 General Guidance	51	APPENDIX E. Working with Partitions.....	78
5.2 Conducting a Periodic Test.....	51	E1. User Interface and Operation	78
6. MAINTENANCE	54	E2. Common Areas.....	78
6.1 Handling System Troubles	54	APPENDIX F. Detector Deployment & Transmitter Assignments.....	79
6.2 Replacing the Backup Battery.....	55	F1. Detector Deployment Plan	79
6.3 Replacing/Relocating Detectors	55	F2. Keyfob Transmitter List	79
6.4 Annual System Check.....	55	F3. Emergency Transmitter List	80
7. READING THE EVENT LOG	56	F4. Non-Alarm Transmitter List	80
APPENDIX A. PowerMaster 360 Configurator ...	57	APPENDIX G. Event Codes.....	81
A1. Working with the PowerMaster Configurator	57	G1. Contact ID Event Codes	81
A2. Manually Installing the USB Driver	63	G2. SIA Event Codes	81
A3. Virtual Keypad Controls.....	68	G3. Understanding the Scancor Reporting Protocol Data Format	82
LED Icons	69	G4. SIA over IP - Offset for Device User	82
Control Keys	69	APPENDIX H. Sabbath Mode	83
Arming Keys	69	H1. General Guidance	83
Other Keys.....	69	H2. Connection	83
APPENDIX B. VISONICconfig Mobile Installer App. For PowerMaster 360.....	70	H3. Arming the System by Sabbath Clock.....	83
B1. Working with the PowerMaster Configurator	70	APPENDIX I. Glossary.....	84
B2. VISONICconfig Controls	73	APPENDIX J. Compliance with Standards.....	86
LED Icons	73	PowerMaster 360 Quick User Guide	89
Control Keys	74		
Arming Keys	74		
Other Keys.....	74		

1. INTRODUCTION

The PowerMaster 360 security and smart home platform is a comprehensive security system based on the PowerMaster™ security logic and PowerG proven RF security technology with IP communication. The PowerMaster 360 platform allows adding cellular (2G or 3G) communication. Property owners receive notifications of events by email and/or SMS. In addition, the system includes a WiFi module that supports IP cameras and a Z-Wave controller that supports Z-Wave devices.

The PowerMaster 360 security system is fully controllable from a computer, and accessible to home and property owners through their mobile devices. Installers program and configure the system remotely through the computer and mobile application's Virtual Keypad (see APPENDIX A / B).

This manual refers to PowerMaster 360 v18 and above. The most updated manuals can be downloaded from the Visonic Web site <http://www.visonic.com>.

The PowerMaster 360 control panel is supplied with 2 instruction manuals:

- **Installer's Guide** (this manual) – for use of system installer during system installation and configuration
- **User's Guide** — also for use of system installer during system installation and configuration, but also for the master user of the system, once installation is completed. Hand over this manual to the master user of the system.

1.1 System Features

The following table lists the PowerMaster 360 features with a description of each feature and how to use it.

<u>Feature</u>	<u>Description</u>	<u>How to configure and use</u>
Visual Alarm Verification	The PowerMaster 360 when used with Next CAM PG2 PIR-camera detector and GPRS communication is able to provide the Monitoring Station with clips captured in alarm situations. The system sends the clips to the Monitoring Station automatically for burglary alarms and, depending on setup, also for fire and personal emergency alarms.	<p>1. Setup GPRS communication: see GSM Module Installation (section 3.4).</p> <p>2. Configure camera settings: refer to the Next CAM PG2 Installation Instructions.</p> <p>3. Enable fire and personal alarm verification: see section 4.6.5 Configuring Motion Cameras for Video Alarm Verification.</p>
On demand clips from cameras	The PowerMaster 360 can provide images from the Next CAM PG2 by demand from a remote PowerManage server. Pictures are taken based on a command from the monitoring station. To protect customers' privacy, the system can be customized to enable the "On Demand View" only during specific system modes (i.e. Disarm, Home & Away) and also to a specific time window following an alarm event.	<p>1. Setup the On demand feature: see section 4.6.5 Configuring Motion Cameras for Video Alarm Verification.</p> <p>2. To request and view images: refer to the PowerManage User's Guide, Chapter 5 Viewing and Handling Events..</p>
Easy Enrollment	PowerG devices are enrolled from the control panel's Virtual Keypad. "Pre-enrollment" can also be performed by entering the PowerG device ID number and then activating the device in the vicinity of the panel.	To enroll or pre-enroll devices: see section 4.4.2 Adding New Wireless Devices.
Device Configuration	<p>Device parameters and related system behavior can be configured from the control panel or from a remote location.</p> <p>Each PowerG device has its own settings which can be configured through the control panel by entering the "DEVICE SETTINGS" menu.</p> <p>Note: <i>The minimum configuration of the system includes one detector.</i></p>	<p>To configure devices from the control panel: see Chapter 4 Programming and also the individual device's Installation Instructions.</p> <p>To configure devices from a remote location: refer to the PowerManage User's Guide Chapter 3 Working with Panels and to the Remote Programmer PC software User's Guide, Chapters 6 and 7.</p>

1. INTRODUCTION

Diagnostics of the control panel and peripherals	You can test the function of all wireless sensors deployed throughout the protected area, to collect information about the received signal strength from each transmitter and to review accumulated data after the test.	To perform diagnostics and to obtain signal strength indication: see section 4.8 Diagnostics.
Conducting periodic tests	The system should be tested at least once a week and after an alarm. The periodic test can be conducted locally or from a remote location (with the assistance from a non-technical person in the house).	To conduct a walk test locally: see Chapter 5 Periodic Test. To conduct a walk test from remote location: refer to the Remote Programmer PC software User's Guide, Chapter 6 Data Details Tables.
Partitions	The partitioning feature, when enabled, divides your alarm system into distinct areas each of which operates as an individual alarm system. Partitioning can be used in installations where shared security systems are more practical, such as a home office or warehouse building.	1. Enable partitioning: see section 4.12 Partitioning. 2. Setup partition association for each device: see section 4.4.2 Adding New Wireless Devices. To understand more about partitioning: see APPENDIX E. Working with Partitions and APPENDIX B. in the User's Guide.
Device configuration templates	The default parameters with which a new device is enrolled into the system can be set before you enroll devices. This default template saves time on device configuration.	1. Define enrollment defaults for devices: see section 4.4.7 Defining Configuration Defaults for "Device Settings". 2. Enroll or pre-enroll devices: see section 4.4.2 Adding New Wireless Devices.
SirenNet - distributed siren using Smoke detectors	All PowerG smoke detectors are able to function as sirens, alerting on any of 4 types of alarm in the system: fire, gas, burglary and flood.	Enable and configure SirenNet for each smoke detector: refer to the SMD-426 PG2 / SMD-427 PG2 Installation Instructions.
Reporting to Private Users and/or Monitoring Station by SMS and IP communication	The PowerMaster 360 system can be programmed to send notifications of alarm and other events to 4 SMS cellular phone numbers and to report these events to the Monitoring Station by SMS or IP communication.	To configure notifications to Private phones: refer to the PowerMaster 360 User's Guide, Chapter 4, section B.12 Programming Email, MMS and SMS Reporting. To configure reporting to the Monitoring Station: see section 4.6.3 Configuring Events Reporting to Monitoring Stations.
Quick installation with link quality indication	With PowerG devices, there is no need to consult the control panel when mounting a wireless device, because PowerG devices include a built-in link quality indicator. Choosing the mounting location is a quick and easy process.	To choose the ideal location to mount a wireless device, see Chapter 2 Choosing the Installation Location.

Device Locator	Helps you to easily identify the actual device displayed on the LCD display.	<p>To read more on the Device Locator: refer to the PowerMaster 360 User's Guide, Chapter 2, Operating the PowerMaster 360 System.</p> <p>To use the device locator when bypassing a zone or when clearing a bypassed zone: refer to the PowerMaster 360 User's Guide, Chapter 4, section B.1 Setting the Zone Bypass Scheme.</p> <p>To use the device locator when conducting the periodic test: see Chapter 5 Periodic Test or refer to the PowerMaster 360 G2 User's Guide, Chapter 7 Testing the System.</p>
Guard key-safe	PowerMaster is able to control a safe that holds site keys that are accessible only to the site's guard or Monitoring Station's guard in the event of an alarm. Operates with the magnetic contact device with auxiliary input only (MC-302E PG2)	<p>1. Configure the safe's zone type to "Guard Zone": see section 4.4.2 Adding New Wireless Devices.</p> <p>2. Setup guard code: see section 4.3 Setting Installer Codes.</p>
Arming Key	External system may control arming and disarming of the PowerMaster system.	Refer to the MC-302 PG2 / MC-302E PG2 / MC-302V PG2 Installation Instructions.

2. CHOOSING THE INSTALLATION LOCATION

2. CHOOSING THE INSTALLATION LOCATION

To ensure the best possible mounting location of the PowerMaster 360 control panel, the following points should be observed:

- The selected location should be approximately in the center of the installation site between all the transmitters, preferably in a hidden location.
- In close proximity to an AC source
- Where there is good cellular coverage, if WCDMA-350 is used
- Far from sources of wireless interference, such as:
 - Computers or other electronic devices, power conductors, cordless phones, light dimmers, etc.
 - Large metal objects (such as metal doors or refrigerators)

Note: A distance of at least 1 meter (3 ft) is recommended.

When mounting wireless devices:







- Make sure that the signal reception level for each device is either "Strong" or "Good", but not "Poor".
- Wireless magnetic contacts should be installed in a vertical position and as high up the door or window as possible.
- Wireless PIR detectors should be installed upright at the height specified in their Installation Instructions
- Repeaters should be located high on the wall in mid-distance between the transmitters and the control panel.

WARNING! To comply with FCC and IC RF exposure compliance requirements, the control panel should be located at a distance of at least 20 cm from all persons during normal operation. The antennas used for this product must not be co-located or operated in conjunction with any other antenna or transmitter.

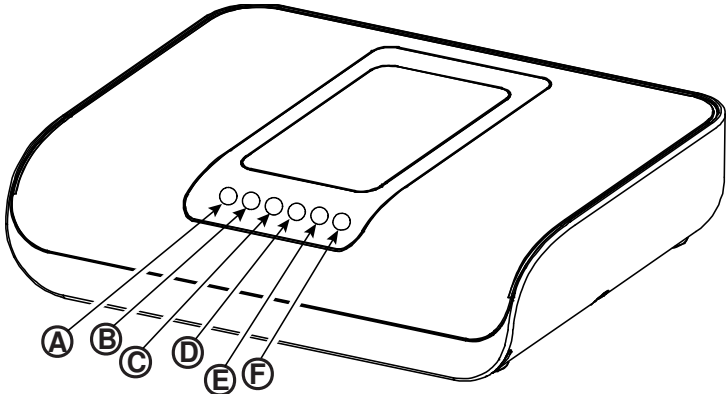
Le dispositif doit être placé à une distance d'au moins 20 cm à partir de toutes les personnes au cours de son fonctionnement normal. Les antennes utilisées pour ce produit ne doivent pas être situées ou exploitées conjointement avec une autre antenne ou transmetteur.

3. INSTALLATION

3.1 Connections and LED Indications

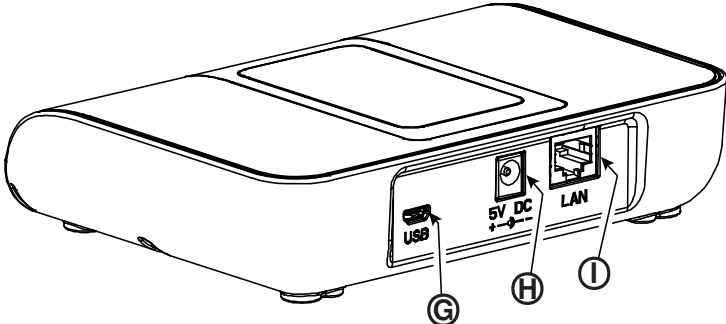
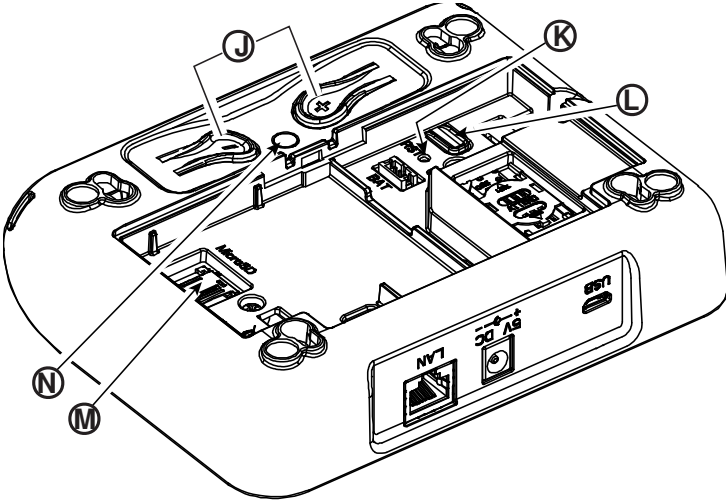
	<ul style="list-style-type: none"> A. Power indication  B. Status indication  C. Trouble indication  D. Service server indication  E. Smart Home Service Indication  F. WiFi indication 
	<ul style="list-style-type: none"> G. Micro USB connection H. 5V DC Power connection I. LAN connection
	<ul style="list-style-type: none"> J. Functional pushbuttons (for future use): <ul style="list-style-type: none"> + button - Add Visonic / Z-Wave devices - button - Delete Visonic / Z-Wave devices K. Hole for reset button L. Back to factory: Press for 30 sec. to restore system parameters to factory default parameters M. Micro SD memory card holder (for future use) N. Enroll LED (for future use)

3. INSTALLATION

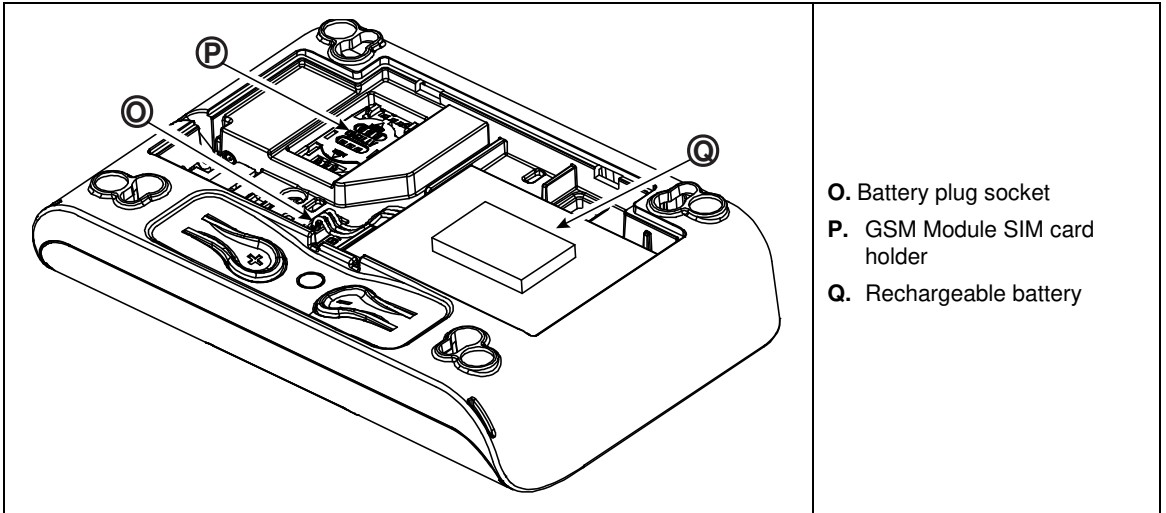
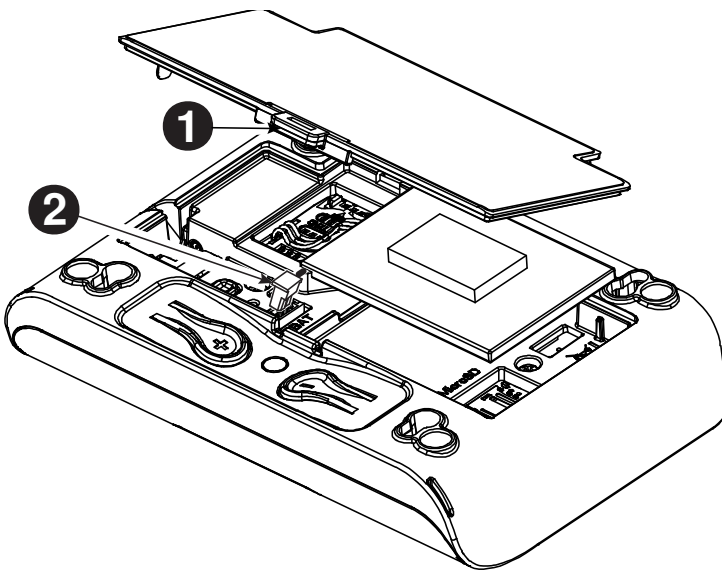

Figure 3.1 – Connections and LED indications

3.2 Inserting the Battery



1. Press on the tab inward and lift to remove the battery cover.
2. Insert the battery cable plug into the battery socket.
3. To close the battery cover, align the two tabs of the battery cover with their respective slots and press down on the cover in the direction shown until a click is heard.

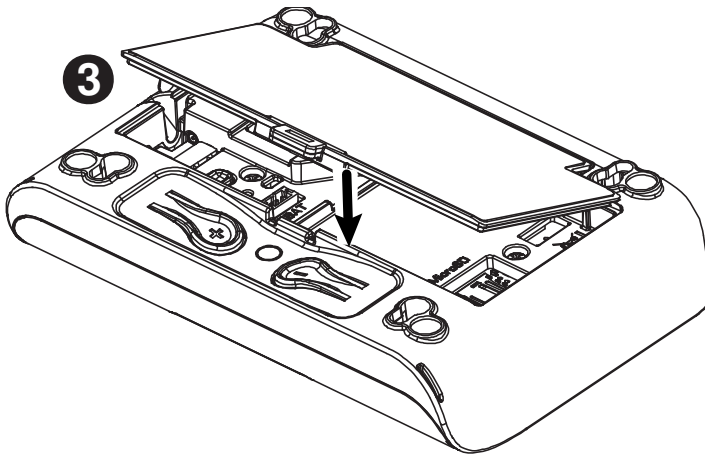
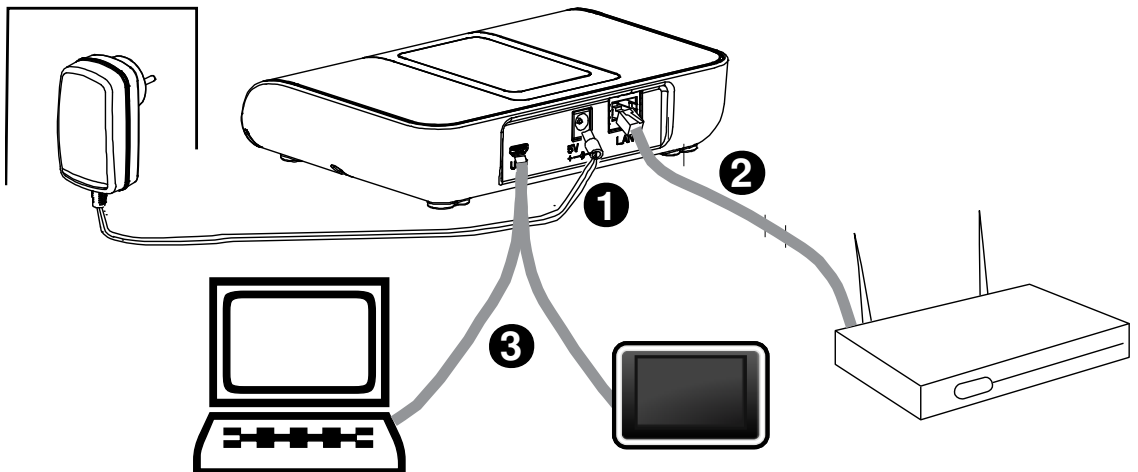

Figure 3.2 – PowerMaster 360 Battery Insertion

3.3 PowerManage 360 Connections



Note: If there is a GSM module in your control panel, connect first the SIM card before performing the following procedure (see section 3.5).

1. Connect the DC power supply from the mains electrical socket to the power connection.
2. Connect the IP cable from the LAN connection to the local home-router connection.
3. To work with the Configurator, connect the micro USB cable from the micro USB connection to the PC/laptop/tablet connection.
4. After completing the setup in the Configurator, disconnect the USB cable from the PowerMaster 360.

Note: See APPENDIX A for using the PC configurator and APPENDIX B for the VISONIConfig.

Figure 3.3 – PowerMaster 360 Panel Connections

3. INSTALLATION

3.4 GSM Connection and Configuration

The GSM modem auto detection feature enables automatic enrollment of the GSM modem into the control panel memory. GSM modem auto detection is activated after reset (power-up or after exiting the Installer Mode menu). This causes the PowerMaster 360 to automatically scan GSM COM ports for the presence of the GSM modem.

In the event that the GSM modem auto detection fails and the modem was previously enrolled in the control panel, the message "Cel Remvd Cnfrm" will be displayed on the Configurator's Virtual Keypad. This message will disappear from the display only after the user presses the <OK> button. The modem is then considered as not enrolled and no GSM trouble message will be displayed.

Notes:

- 1) A message is displayed only when the alarm system is disarmed.
- 2) The GSM Alarm Transmission System is designed to comply with EN 50131-1 ATS4.

3.5 SIM Card Insertion

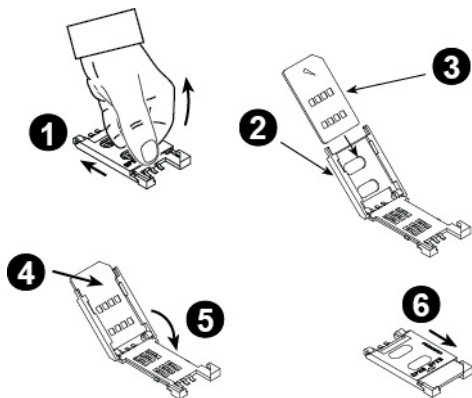

Insert the SIM card into the GSM module (indicated "O" in section 3.1 above) as shown in the drawing.

1. Slide top cover.
2. Open cover
3. Align SIM card in cover (note cover orientation)
4. Slide SIM card into cover
5. Rotate cover to close
6. Lock cover to close

IMPORTANT! Do not insert or remove the SIM card when the control panel is powered by AC power or battery.

To configure the GSM modem, see section 4.6.2.

3.6 PowerMaster 360 Prerequisites

Connection to PowerManage requires the following ports to be open on the router. From home to internet:

- TCP ports : 8080, 5001
- UDP port: 5001
- FTP port: 21

Note: In a typical home router these ports should already be open.

The Windows 7 PC Operation System is supported for the Configurator.

3.7 Enrolling / Deleting a Z-Wave Device

Enrolling a Z-Wave Device

To enroll a device, proceed as follows.

1. Press and hold the (+) button ("J" in Figure 3.1) for 2 seconds. The red LED ("N" in Figure 3.1) blinks slowly.
2. Press the device Enroll button.
3. If Enroll is successful, the green LED blinks quickly and a happy beep is heard and then the LED turns off.

Notes:

1. To abort enrollment during this stage, press and hold the (+) or (-) buttons for 2 seconds. The LED will stop blinking.
2. If enroll fails, the red LED lights constantly for 3 seconds and a sad beep is heard.
3. Long press on the (+) button, returns the panel to normal operation.

Deleting a Z-Wave Device

To delete an enrolled device, proceed as follows.

1. Press and hold the (-) button ("J" in Figure 3.1) for 2 seconds. The red LED ("N" in Figure 3.1) blinks quickly and a happy beep is heard and then the LED turns off.

Notes:

1. To abort the procedure during this stage, press and hold the (+) or (-) buttons for 2 seconds. The LED will stop blinking.
2. If the procedure fails, the red LED lights constantly for 3 seconds and a sad beep is heard.
3. Long press on the (-) button, returns the panel to normal operation

3.8 Panel Reset

To reset the panel, use a blunt instrument to press the Reset button ("K" in Figure 3.1), or, alternatively, exit the Installer Mode. The Orange LED ("N" in Figure 3.1) lights constantly until Panel initialization is completed and the PowerLink is reset. Finally, the Orange LED ("N") turns off.

3.9 Factory Default Restore

This procedure is performed to restore system parameters to factory default parameters. Back to Factory can be performed only when the panel is in the Disarmed state.

1. Press the Back to Factory button ("L" in Figure 3.1) for 30 seconds.

Note: During Back to Factory, the red LED ("N" in Figure 3.1) blinks.

2. If Back to Factory is successful: the green LED blinks 3 times and a happy beep is heard and then the panel immediately initiates software reset.

Note: If the Back to Factory procedure fails, the red LED lights constantly for 3 seconds and a sad beep is heard.

4. PROGRAMMING

4.1 General Guidance

This chapter explains the Installer programming (configuration) options of your PowerMaster 360 system and how to customize its operation to your particular needs and end user requirements.

Software configuration of the alarm system is performed using the Virtual Keypad which contains the control keys, numerical keypad and display.

The control panel includes a partition feature. Partitioning allows you to have up to three independently controllable areas with different user codes assigned to each partition. A partition can be armed or disarmed regardless of the status of the other partitions within the system.

The Soak Test feature allows selected zones to be tested for a pre-defined period of time. When in Soak Test mode, activating a zone does not cause an alarm and siren and strobe are not activated. The zone activation is recorded in the event log and is not reported to the Monitoring Station. The zone remains in Soak Test until the pre-defined period of time for the Soak Test has elapsed without any alarm activation. The zone then automatically removes itself from Soak Test mode and returns to normal operating mode.

Software Upgrade allows you to upgrade the software of the control panel from the remote PowerManage server. During software upgrade, the PowerMaster 360 Virtual Keypad display will read "UPGRADING..." which is displayed throughout the software upgrade procedure.

Note: Software Upgrade cannot be performed when the control panel is armed AWAY or there is an AC failure.

Tech Tip :

For your convenience, we recommend programming the PowerMaster 360 on the work bench before actual installation. Operating power may be obtained from the backup battery or from the AC power supply.







ATTENTION! FIRST SWITCH ON THE CONTROL PANEL and then INSERT BATTERIES INTO ACCESSORIES DEVICES.

The devices "search" for the control panels to which they are enrolled for a period of only 24 hours from the time of battery insertion.

Note: If you have switched on the control panel a long time after inserting batteries into the accessories devices: Open and then close the cover to activate the tamper switch (where applicable), or remove the battery and then put back the battery.

4.1.1 Navigation

The Virtual Keypad's buttons are used for navigation and configuration when programming. The following table provides a detailed description of the function or use of each button.

Button	Definition	Navigation / Setting Function
	NEXT	Use to move / scroll forward to the next menu options.
	BACK	Use to move / scroll backward to the previous menu options.
	OK	Use to select a menu option or to confirm a setting or action .
	HOME	Use to move one level up in the menu or to return to previous setting step .
	AWAY	Use to jump back to the [<OK> TO EXIT] screen to quit programming.
	OFF	Use to cancel, delete, clear or erase setting, data, etc.
0 – 9		Numerical keypad used to enter numerical data when needed.





Note: The above buttons are identical in function to the corresponding buttons shown throughout the document.

To review the options within the control panel menus and select an option, repeatedly press the Next  or Back

 button until the desired option is displayed (also designated as   in this guide), then press the OK 

button to select the desired option (also designated as  in this guide). To return to the previous options repeatedly

press the Home  button and to exit the programming menu press the Away  button.





To simplify the procedure further, you really need two basic buttons to program the entire panel: The Next  and the OK  button. The  button scrolls through the options, and the  button selects the option

you want.

4. PROGRAMMING

4.1.2 Feedback Sounds

The sounds you will hear via the Configuration device (PC or mobile) while using and configuring the control panel are:

Sound	Definition
	Single beep, heard whenever a key is pressed
	Double beep, indicates automatic return to the normal operating mode (by timeout).
	Three beeps, indicates a trouble event
	Happy Tune (- - - —), indicates successful completion of an operation.
	Sad Tune (—), indicates a wrong move or rejection

4.2 Entering the "Installer Mode" and Selecting a Menu Option

All Installer Mode menu options are accessed via the "Installer Mode" which is usually one of the main panel menu options.

To enter the "Installer Mode" and select an Installer Mode menu option proceed as follows:

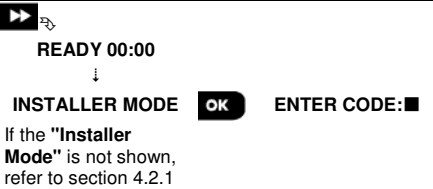
Step 1	Step 2	Step 3	Step 4														
Select "INSTALLER MODE" Option [1]	Enter Installer Code [2]	Select Installer Mode menu option [3]															
 <p>If the "Installer Mode" is not shown, refer to section 4.2.1</p>		<table border="1"> <thead> <tr> <th>See</th> <th>See</th> </tr> </thead> <tbody> <tr> <td>01:INSTALL CODES 4.3</td> <td>08:USER SETTINGS 4.9</td> </tr> <tr> <td>02:ZONES/DEVICES 4.4</td> <td>09:FACTORY DEFLT 4.10</td> </tr> <tr> <td>03:CONTROL PANEL 4.5</td> <td>10:SERIAL NUMBER 4.11</td> </tr> <tr> <td>04:COMMUNICATION 4.6</td> <td>12:PARTITIONING 4.12</td> </tr> <tr> <td>06:CUSTOM NAMES 4.7</td> <td>13:OPERATION MOD 4.13</td> </tr> <tr> <td>07:DIAGNOSTICS 4.8</td> <td><OK> TO EXIT</td> </tr> </tbody> </table>	See	See	01:INSTALL CODES 4.3	08:USER SETTINGS 4.9	02:ZONES/DEVICES 4.4	09:FACTORY DEFLT 4.10	03:CONTROL PANEL 4.5	10:SERIAL NUMBER 4.11	04:COMMUNICATION 4.6	12:PARTITIONING 4.12	06:CUSTOM NAMES 4.7	13:OPERATION MOD 4.13	07:DIAGNOSTICS 4.8	<OK> TO EXIT	<p>Go to the indicated section of the selected option</p>
See	See																
01:INSTALL CODES 4.3	08:USER SETTINGS 4.9																
02:ZONES/DEVICES 4.4	09:FACTORY DEFLT 4.10																
03:CONTROL PANEL 4.5	10:SERIAL NUMBER 4.11																
04:COMMUNICATION 4.6	12:PARTITIONING 4.12																
06:CUSTOM NAMES 4.7	13:OPERATION MOD 4.13																
07:DIAGNOSTICS 4.8	<OK> TO EXIT																

① - Entering the "Installer Mode" menu

- [1] You can access the "Installer Mode" only when the system is disarmed. The process described refers to the case where "User permit" is not required. If "User permit" is required, select the "User Settings" option and ask the Master User to enter his code and then scroll the "User Settings" menu and select the "Installer Mode" option (last option in the menu). Continue to Step 2.
- [2] If you have not already changed your Installer code number, use the default settings: 8888 for installer & 9999 for master installer.
If you enter an invalid installer code 5 times, the keypad will be automatically disabled for a pre-defined period of time and the message **WRONG PASSWORD** will be displayed.
- [3] You have now entered the **Installer Mode menu**. Scroll and select the menu you wish and continue to its corresponding section in the guide (indicated on the right side of each option).

4.2.1 Entering the "Installer Mode" if "User Permit" is enabled

In certain countries the regulations may require **user permission** to make changes in the configuration of the panel. To comply with these regulations, the "Installer Mode" option can be accessed only via the "User Settings" menu. The Master user must first enter the "User Settings" menu then scroll until the "Installer Mode" option is shown and then the installer can continue as shown in the above table (see also ① [1] in Step 1 above).

To configure the panel to comply with **user permission** requirements - see option #91 "User Permit" in section 4.5.8.

4.2.2 Selecting options



① ① – Selecting an option from a menu

Example: To Select an Option from the "COMMUNICATION" menu:

- [1] Enter the **Installer Mode** menu and select the "**04.COMMUNICATION**" option (see section 4.2).
- [2] Select the sub-menu option you need, for example: "**3: C.S. REPORTING**".
- [3] Select the parameter you wish to configure for example: "**11:RCVR 1 ACCOUNT**".
- [4] To continue, go to the section of the selected sub-menu option, for example section 4.6.3 for the "**3:C.S.REPORTING**" menu, and look for the sub-menu you wish to configure (e.g. "**11:RCVR 1 ACCOUNT**"). After configuring the selected parameter the display returns to step 3.



To Change the Configuration of the Selected Option:

When entering the selected option, the display shows the default (or the previously selected) **setting** marked with ■.



To change the configuration, scroll  the "Options" menu and select the setting you wish and press  to confirm. When done, the display reverts to Step 3.

4.2.3 Exiting the Installer Mode

To exit the Installer Mode, proceed as follows:

Step 1	①	Step 2	①	Step 3	①
	[1]		[2]		[3]
Any screen	 or 	<OK> TO EXIT		READY 12:00	

① ① – Exiting the Installer Mode

- [1] To exit "**INSTALLER MODE**", move up the menu by pressing the  button repeatedly until the display reads "<OK> TO EXIT" or preferably; press the  button once which brings you immediately to the exit screen "<OK> TO EXIT".
- [2] When the display reads "<OK> TO EXIT", press .
- [3] The system exits the "**INSTALLER MODE**" menu and returns to the normal disarm state while showing the READY display.

4.3 Setting Installer Codes

The PowerMaster 360 system provides two installer permission levels with separate installer codes, as follows:

- **Master Installer:** The "Master Installer" is authorized to access all Installer Mode menu and sub-menu options. The default code is: 9999 (*).
- **Installer:** The "Installer" is authorized to access most but not all Installer Mode menu and sub-menu options. The default code is 8888 (*).
- **Guard Code:** Enables an authorized guard to only Arm Away / Disarm the control panel. The default code is 0000 (*).

The following actions can be performed only by using the **Master Installer code**:











- Changing the Master Installer code.
- Defining specific communication parameters – see "**3:C.S REPORTING**" in sections 4.6.2 and 4.6.3.
- Resetting the PowerMaster 360 parameters to the default parameters – see "**09:FACTORY DEFLT**" in section 4.11.

Note: Not every system includes a **Master Installer code** feature. In such systems, the **Installer** can access all Installer Mode menu and sub-menu options the same as a Master Installer.

(* **You are expected to use the default codes only once for gaining initial access, and replace it with a secret code known only to yourself.**

4. PROGRAMMING

To change your Master Installer or Installer Codes proceed as follows:

Step 1	Step 2	Step 3	Step 4
Select "01:INSTALL CODES" Option	Select Master Installer , Installer code or Guard code	Enter NEW Master Installer , Installer code or Guard code	
			
INSTALLER MODE  ENTER CODE:■ ▼	NEW MASTER CODE ▼ or NEW INST. CODE ▼ or NEW GUARD CODE	MASTER CODE ■999 or INST. CODE ■888 or GUARD CODE ■000	 to step 2  to step 2  to step 2
01:INSTALL CODES 			

① ① – Setting Installer Codes

- [1] Enter the **Installer Mode** menu and select the "01:INSTALL CODES" option (see section 4.2).
- [2] Select the "NEW MASTER CODE", "NEW INST. CODE" or "NEW GUARD CODE". Some panels may have only the Installer Code and New Guard Code option.
- [3] Enter the new 4-digit Code at the position of the blinking cursor and then press .

Notes:

1. Code "0000" is not valid for Master Installer or installer.
2. Inserting "0000" for the Installer will delete the Installer Code.
3. **Warning! Always use different codes for the Master Installer, for the Installer and for the Users.**
If the Master Installer Code is identical to the Installer code, the panel will not be able to recognize the Master Installer. In such a case, you must change the Installer code to a different code. This will re-validate the Master Installer code.

4.3.1 Identical Installer and Master Installer Codes

In a 2-installer code system, the non-master installer may inadvertently change his Installer Code to that of the Master Installer Code. In this case, the panel will allow the change in order to prevent the non-master installer from realizing the discovery of the Master Installer's Code. The next time the Master Installer enters the Installer Mode the Master Installer will be considered as an Installer and not as a Master Installer. In such a case the Master Installer should use one of the following solutions:





- (a) Access the panel using the Remote Programmer PC software application and change the Master Installer Code to a different code than the one programmed by the Installer.
- (b) 1. Change the Installer Code to a temporary code, 2. exit the Installer Mode, 3. enter the Installer Mode again using the Master Installer code (the Master Installer Code will now be accepted), 4. change the Master Installer code to a different code, 5. and change the NON-Master Installer Code back again (in other words, undo the change to the temporary code) so that the NON-Master Installer can still enter the system.

4.4 Zones / Devices

4.4.1 General Guidance & Zones/Devices Menu Options

The ZONES/DEVICES menu enables you to add new devices to the system, to configure them and to delete them, if required.

To select an option follow the instructions below. Additional details and guidance are provided in section 4.2.

INSTALLER MODE	 02:ZONES/DEVICES	 MENU you wish	 indicates scroll	 and select	
----------------	--	---	--	--	---

Option	Use	Section
ADD NEW DEVICES	Use to enroll and configure the device's operation according to your preference and in case of sensors to also define their zone name (location), zone type and chime operation.	4.4.2
DELETE DEVICES	Use to delete devices from the system and to reset their configuration.	4.4.3
MODIFY DEVICES	Use to review and/or change the device's configuration.	4.4.4
REPLACE DEVICES	Use to replace faulty devices with automatic configuration of the new device.	4.4.5
ADD TO SOAK TEST	Use to enable the Soak Test for device zones.	4.4.6
DEFINE DEFAULTS	Use to customize the defaults of the device's parameters according to your personal preferences for each new device enrolled in the system.	4.4.7

4.4.2 Adding New Wireless Devices

Part A - Enrollment

To enroll and configure a device, follow the instructions in the following chart

Step 1	Step 2	Step 3	Step 4
Select "ADD NEW DEVICE" Option [1]	Enroll the device or Enter the device ID [2]	Select a Zone number [3]	Configure zone & device Parameters [4]

①	① - Adding New Devices
[1]	Enter "INSTALLER MODE", select "02:ZONES DEVICES" (see section 4.2) and then select "ADD NEW DEVICE". Because of encryption, PowerG devices (including Keyfobs) cannot be used on more than one system at one time. Remember to verify panel and device compatibility.
[2]	See enrollment by button or device ID below. If enrollment is successful, the display reads "DEVICE ENROLLED" (or "ID ACCEPTED") and then shows the device details - see [3]. However, if the enrollment fails, the display will advise you the reason for failure, for example: "ALREADY ENROLLED" or "NO FREE LOCATION". If the enrolled device is adapted to operate as another device that the panel recognizes, the display then reads "ADAPTED TO <OK>".
[3]	The display shows the device details and the first available free Zone number for example: "Z01:Motion Sensor > ID No. 120-1254" (or "K01:Keyfob / S01:Siren etc. depending on the type of the enrolled device). Detectors can be enrolled in any zone number. To change the zone number, click the button or type in the zone number, and then press to confirm.
[4]	Continue to Part B to configure the device – see diagram below

How to check Panel ↔ Device compatibility

Each PowerG device bears a 7-character Customer ID printed on the device sticker in the format: FFF-M:DDD, (for example, 868-0:012) where FFF is the frequency band and M:DDD is the variant code.

For PowerG system devices compatibility, make sure the frequency band (FFF) and the variant code (M) of the devices match. The DDD can be ignored if the panel displays "ANY" for DDD.

Enrollment by using Device ID

The 7-digit Device ID can be used to register a device into the panel locally or from a remote location using the Remote Programmer PC software. The enrollment by device ID is a 2 stage procedure.

In the 1st stage you register the devices' ID numbers into the panel and complete the device configuration. This can be done from a remote location using the Remote Programmer PC software. Following the 1st stage, the PowerMaster 360 panel waits for the device to appear on the network in order to complete the enrollment.

In the 2nd stage, the enrollment is completed when the panel is in full working mode by inserting the battery into the device, or by pressing the tamper or enrollment button on the device. This procedure is very useful for adding devices to existing systems without the need to provide technicians with the Installer Code, or to allow access to the programming menus.

Remember! The system will indicate a "NOT NETWORKD" trouble until the 2nd stage of all registered devices is completed.

Note: The Soak Test on pre-enrolled zones can be activated only when the zone is fully enrolled.

Enrollment by using the Enrollment button

The panel is set to the Enrollment mode (step #2 above) and the device is enrolled using the Enroll button (refer to the device information in the device Installation Instructions, then open the device and identify the **Enroll button**). For keyfobs and keypads, use the **AUX '*'** button. For gas detectors, **insert the battery**.

Press the enroll button for 2-5 seconds until the LED lights steadily and then release the button. The LED will extinguish or may blink for a few more seconds until the enrollment is completed. If enrollment is successfully

4. PROGRAMMING

completed, the PowerMaster 360 sounds the "Happy Tune" and the Virtual Keypad momentarily shows "**DEVICE ENROLLED**" and then reads the device details.

Part B - Configuration

Step 1	Step 2	Step 3	Step 4
Enter Location Menu [1]	Select Location [2] <i>(see list below)</i>	Enter Zone Type [3]	Select Zone Type [4] <i>(see list below)</i>
Z10:LOCATION	Dining room ↓ Custom 5	Z10:ZONE TYPE	1:Exit/Entry1 ↓ 5. Interior
Step 5	Step 6	Step 7	Step 8
Enter Chime Menu [5]	Select Chime option [6]	Enter Partitions Menu [7]	Select Partition options [8]
Z10:SET CHIME	chime OFF ↓ melody-chime	Z10:PARTITIONS	Z10:P1 P2 P3
Step 9	Step 10	Step 11	
Enter Device Settings Menu [9]	Configure Device Parameters [10]	Continue or End	
Z10:DEV SETTINGS	Refer to device datasheet in the device Installation Instructions for specific configuration instructions.	To continue – See ① [11]	

①	① - Configuring New Devices
	Location (name) setting:
[1]	To review or change the Location (name) setting, press the button, otherwise scroll to the next option.
[2]	To change the Location name, enter the menu and select the name from the " Location List " below. You can assign additional custom names using the " 06.CUSTOM NAMES " option in the Installer Mode menu. See section 4.7. Note: As a shortcut, press the 2 digit serial No. of the Custom Location, which takes you directly to its menu.
	Zone Type setting:
[3]	To review or change the Zone Type setting, press the button, otherwise scroll to the next option.
[4]	The zone type determines how the system handles signals sent from the device. Press and select a suitable zone type. The list of available Zone Types and the explanation for each zone type is provided below. Note: As a shortcut, press the 2 digit serial No. of the Zone Type shown in the Location List below, which takes you directly to its menu.
	Chime setting:
[5]	All zones are set to chime OFF by default. To configure the device to cause the panel to sound (when disarmed) a Chime melody when tripped, press the button, otherwise scroll to the next option.
[6]	Select between " Chime OFF ", " melody-chime " and " zone name-chime ". In "melody chime" the control panel sounds a chime melody when the sensor is tripped. In "zone name-chime" the control panel sounds the zone name when the sensor is tripped. The chime operates during the Disarm mode only.
	Partitions setting:
	Note: The " PARTITIONS " menu appears only if Partitions is enabled in the control panel (see section 4.12).
[7]	When entering the menu, the display shows the default Partition selection (marked with).
[8]	Use the keypad keys to assign partitions to the device.
	Device Configuration:
[9]	To review or change the Device Configuration (settings) , press the button, otherwise scroll to the next option – see ① [11].
[10]	To configure the device parameters, refer to its corresponding device datasheet in the device Installation Instructions. The defaults of the device parameters can be also configured as explained in section 4.4.7.
[11]	After completing the configuration of the device, the wizard brings you to the " Next Step " menu with the following 3 options:

4. PROGRAMMING

① - Configuring New Devices

"NEXT Device" to enroll the next device.

"MODIFY Same Dev." reverts to Step 1 (i.e. "LOCATION") to allow you to perform additional changes to the device, if needed.

"EXIT Enrollment" exits the enrollment procedure and returns to Step 1 bringing you back to the "ADD NEW DEVICES" menu.

Location List

No.	Location Name	No.	Location Name	No.	Location Name	No.	Location Name
01	Attic	09	Dining Room	17	Hall	25	Utility Room*
02	Back door	10	Downstairs	18	Kitchen*	26	Yard
03	Basement	11	Emergency	19	Laundry Room*	27	Custom1*
04	Bathroom	12	Fire	20	Living Room*	28	Custom2*
05	Bedroom	13	Front Door	21	Master Bath*	29	Custom3*
06	Child room	14	Garage	22	Master Bedr	30	Custom4*
07	Closet	15	Garage Door	23	Office	31	Custom5*
08	Den	16	Guest Room	24	Upstairs		

* Can be customized by "06:CUSTOM NAMES" menu (see section 4.7)

Zone Type List

No.	Zone Type	Description
1.	Exit/Entry 1	This Zone starts the exit time when the user arms the system or the entry time when the system is armed. To configure the Exit/Entry 1 time, see sections 4.5.1 & 4.5.2 - Installer Mode menu "03.CONTROL PANEL" options 01 and 03. (*)
2.	Exit/Entry 2	Same as Exit / Entry 1 but with a different delay time. Used sometimes for entrances closer to the panel. For configuring the Exit and Entry 2 delays, see sections 4.5.1 & 4.5.2 – Installer Mode menu "03.CONTROL PANEL" options 02 and 03. (*)
3.	Home Delay	Used for Door/Window Contacts and Motion sensors protecting entrance doors to interior living areas where you wish to move feely when the system is armed HOME. Functions as a "Delayed" zone when the system is armed HOME and as a "Perimeter Follower" zone when the system is armed AWAY.
4.	Inter-Follow	Similar to "Interior" zone but temporarily ignored by the alarm system during entry/exit delay periods. Usually used for sensors protecting the route between the entrance door and the panel.
5.	Interior	This zone type generates an alarm only when the system is armed AWAY but not when the system is armed HOME. Used for sensors, installed in interior areas of the premises, that need to be protected when people are not present inside the premises.
6.	Perimeter	This zone type generates an alarm when the system is armed both in AWAY and HOME modes. Used for all sensors protecting the perimeter of the premises.
7.	Perim-Follow	Similar to "Perimeter" zone, but is temporarily ignored by the alarm system during entry/exit delay periods. Usually used for sensors protecting the route between the entrance door and the control panel.
8.	24h silent	This zone type is active 24 hours, even when system is DISARMED. It is used to report alarm events from sensors or manually activated buttons to the Monitoring Station or private telephones (as programmed) without activating the sirens.
9.	24h audible	Similar to 24hr silent zone, but also provides an audible siren alarm. Note: This zone type is used only for burglary applications.
10.	Emergency	This zone type is active 24 hours, even when the system is DISARMED. It is used to report an emergency event and to initiate an Emergency call to the Monitoring Stations or private telephones (as programmed).
11.	Arming Key	An Arming key zone is used to control the arming and disarming of the system. Note: Operates with the magnetic contact device, magnetic contact device with auxiliary input and vanishing magnetic contact device.
12.	Non-Alarm	This zone does not create an alarm and is often used for non-alarm applications. For example, a detector used only for sounding a chime.
13.	Fire	A Fire zone is used for connecting the MC-302E (magnetic contact with hard-wired input) to a wired smoke detector.
17.	Guard keybox	A Guard keybox zone is usually connected to a metal safe containing the physical keys needed to enter the building. Following an alarm, the safe becomes available to a trusted Guard who can open the Guard keybox, obtain the keys and enter the secured premises. The

No.	Zone Type	Description
18	Outdoor	Guard keybox zone acts just like a 24H audible zone. The Guard keybox zone also provides automatic audible internal and external siren alarm that is immediately reported to the Monitoring Station (and does not depend on the Abort Time). Notes: 1. Opening/closing the Guard keybox causes the PowerMaster 360 to signal the Monitoring Station. 2. Operates with the magnetic contact device with auxiliary input.
(*)		A zone for outdoor areas where an activated alarm does not indicate intrusion into the house. Note: The PIR camera / Outdoor PIR camera detector cannot be set to Outdoor Zone Type. These Zone types are useful mainly when you arm and disarm the system from inside the protected premises. If you arm and disarm the system from outside (without tripping any sensor), such as using a keyfob, it is preferred to use the other Zone Types.

4.4.3 Deleting a Device

Step 1	Step 2	Step 3	Step 4	Step 5
Select "DELETE DEVICES" Option [1]	Select the respective device Group [2]	Select exact device you wish to delete [3]	To delete the device: press the key [4]	
02:ZONES DEVICES ↓ DELETE DEVICES	CONTACT SENSORS ↓ MOTION SENSORS	Z01:Motion Sens ID No. 120-1254	<OFF> to delete	to step 2

- ① ① – Deleting a Device**
- [1] Enter the **Installer Mode Menu**, select the "02.ZONES/DEVICES" option (see section 4.2) and then select the "DELETE DEVICES" option.
 - [2] Select the respective group of the device you wish to delete. For example, "MOTION SENSORS".
 - [3] Scroll the Device Group, identify (by zone and/or ID number) the exact device you wish to replace, for example: "Z01: Motion Sensor > ID No. 120-1254" and press the button.
 - [4] The display prompts you "<OFF> to delete". To delete the device, press the (OFF) button.

4.4.4 Modifying or Reviewing a Device

To **Modify** or **Review** the device parameters proceed as follows:

Step 1	Step 2	Step 3	Step 4	Step 5
Select "MODIFY DEVICES" Option [1]	Select the respective device Group [2]	Select exact device you wish to modify [3]	Select the Parameter you wish to modify [4]	Modify the Parameter
02:ZONES DEVICES ↓ MODIFY SENSORS	CONTACT SENSORS ↓ MOTION SENSORS	Z10:Motion Camra ID No. 140-1737	Z10:LOCATION Z10:ZONE TYPE Z10:SET CHIME Z10:PARTITIONS Z10:DEV SETTINGS	See ① [4] When done to step 2





- ① ① – Modifying or Reviewing a Device**
- [1] Enter the **Installer Mode menu**, select the "02:ZONES/DEVICES" option (see section 4.2) and then select the "MODIFY DEVICES" option.
 - [2] Select the respective group of the device you wish to review or modify. For example, "MOTION SENSORS".
 - [3] Scroll the Device Group, identify (by zone and/or ID number) of the exact device you wish to modify or review, for example: "Z10:Motion Camra > ID No. 140-1737".
 - [4] From here on the process is same as the configuration process that follows the enrollment of that device. To continue, refer to Section 4.4.2 "Adding a New Wireless Device" Part B. When done, the display will show the next device of the same type (i.e. "Motion camera").

4. PROGRAMMING

4.4.5 Replacing a Device

Use this option to replace a faulty device that is enrolled in the system with another device of the same type number (i.e. same first 3 digit of the ID number – see section 4.4.2.A) while keeping the same configuration of the original device. There is no need to delete the faulty device or to reconfigure the new device. Once enrolled, the new device will be configured automatically to the same configuration of the faulty (replaced) device.

To **Replace**, a device proceed as follows:

Step 1	Step 2	Step 3	Step 4	Step 5
Select "REPLACE DEVICES" Option [1]	Select the respective device Group [2]	Select exact device you wish to replace [3]	Enroll the new device [4]	
 02:ZONES/DEVICES ↓ REPLACE DEVICES	 CONTACT SENSORS ↓ KEYFOBS	 K03:Keyfob ID No. 300-0307	 ENROLL NOW or ENTR ID:300-XXXX	See ① [4].





① ① – Replacing a Device

- Enter the **Installer Mode menu**, select the "02:ZONES/DEVICES" option (see section 4.2) and then select the "REPLACE DEVICES" option.
- Select the respective group of the device you wish to replace. For example, "KEYFOBS".
- Scroll the Device Group, identify (by zone and/or ID number) the exact device you wish to replace, for example: "K03: Keyfob > ID No. 300-0307".
If you try enrolling a new device of a different type than the replaced device, the PowerMaster 360 will reject the new device and the Virtual Keypad display will read "WRONG DEV.TYPE".
When done, the Virtual Keypad display shows the device details of the new device.

4.4.6 Configuring Soak Test Mode

This option enables you to enter device zones into Soak Test mode.

To **Enable** the Soak Test proceed as follows:

Step 1	Step 2	Step 3	Step 4	Step 5
Select "ADD TO SOAK TEST" Option [1]	Select the respective device Group [2]	Select device zone number [3]	Select to enable or disable the Soak Test [4]	[5]
 02:ZONES/DEVICES ↓ ADD TO SOAK TEST	 CONTACT SENSORS ↓ MOTION SENSORS	 Z09:Motion Sens ID No. 120-2468	 Disable test ■ Enable test	See ① [5] ↵ to Step 3

① ① – Enabling Soak Test mode



- Enter the **Installer Mode menu**, select the "02.ZONES/DEVICES" option (see section 4.2) and then select the "ADD TO SOAK TEST" option.
- Select the respective Group of the device you wish to add the Soak Test. For example, "MOTION SENSORS".
- Scroll to select the specific device zone number.
- Select between "Disable test" (default) or "Enable test".
- If set to "Enable Test" you must set the duration of the Soak Test before the Soak Test will start (see section 4.5.8). You can stop the test for the relevant zone by changing the setting to "Disable test" at any time during the testing period. All Soak test zones will be reset to start a new test upon occurrence of one of the following:
1) Power up of the system; 2) Setup of Factory Default; 3) Change in system Soak Time.

4.4.7 Defining Configuration Defaults for "Device Settings"

PowerMaster 360 enables you to define the **Default Parameters** used during enrollment and to change them whenever you wish so that new devices enrolled into the system will be configured automatically with these default parameters without the need to modify the configuration of each new enrolled device. You can use a certain set of defaults for certain group of devices and then change the defaults for another group.

IMPORTANT! Devices that were already enrolled in the PowerMaster 360 system before the defaults have been changed will not be affected by the new default settings.

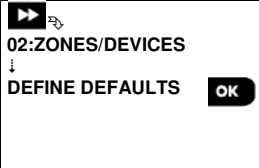
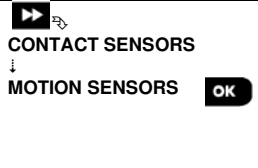
To **Define** the Default parameters of a device Group proceed as follows:

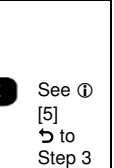
Step 1	Step 2	Step 3	Step 4	Step 5
Select "DEFINE DEFAULTS" Option [1]	Select the respective device Group [2]	Select the Default Parameter [3]	Select the new Default Setting [4]	[5]
				

① ① – Changing Defaults

- [1] Enter the **Installer Mode menu**, select the "02.ZONES/DEVICES" option (see section 4.2) and then select the "DEFINE DEFAULTS" option.
- [2] Select the respective Group of the device you wish to define its defaults. For example, "**MOTION SENSORS**".
- [3] Scroll the parameter list of the Device Group and select the Default Parameter you wish to change, for example: "**Event Counter**". The list combines the parameters of all devices in the group, for example, the parameters of all types of Motion sensors.
- [4] In the example, the existing default setting of the "Event Counter" for enrolled motion sensors was "Low Sensitivity" (marked with **■**). To change it to "**High**", scroll the menu until the display shows "**High**" and press the  button. The new default for the Event Counter parameter setting of Motion Sensors enrolled from now on will be "**High**".
- [5] The new default does not affect motions sensors that were already enrolled before the change was made but only new motion sensors that will be enrolled in the PowerMaster 360 after the change is performed.

4.4.8 Updating Devices after Exiting Installer Mode

When exiting the "**Installer mode**", the PowerMaster 360 panel communicates with all devices in the system and updates them with the changes that have been performed in their "Device Settings" configuration. During the updating period, the display indicates "**DEV UPDATING 018**" where the number (for example, 018) is a countdown of the remaining number of devices yet to be updated.

4.5.2 Configuring Arming/Disarming and Exit/Entry Procedures

The following table provides you with a detailed description of each option and its configuration settings. To select an option and change its configuration – refer to section 4.5.1.

Option	Configuration Instructions
01:ENTRY DELAY1 02:ENTRY DELAY2	<p>Two different entry delays allow the user to enter the protected site (while the system is in the armed state) via dedicated exit/entry doors and routes without causing an alarm.</p> <p>Following entry, the user must disarm the control panel before the entry delay expires. Slow-rate warning beeps start sounding via the Configuration device (PC or mobile) once the door is opened, until the last 10 seconds of the delay, during which the beeping rate increases. The "ENTRY DELAY 1" and "ENTRY DELAY 2" options allow you to program the time length of these delays.</p> <p>Options: 00 seconds; 15 seconds (default for entry delay 2); 30 seconds (default for entry delay 1); 45 seconds; 60 seconds; 3 minutes and 4 minutes.</p> <p>Notes:</p> <ol style="list-style-type: none"> 1. In some PowerMaster 360 variants, these menus are displayed in the Operation Mode only (see section 4.13). 2. To comply with EN requirements, the entry delay must not exceed 45 sec.
03:EXIT DELAY	<p>This option allows programming the time length of the exit delay. An exit delay allows the user to arm the system and leave the protected site via specific routes and exit/entry doors without causing an alarm. Slow-rate warning beeps start sounding via the Configuration device (PC or mobile) once the arming command has been given, until the last 10 seconds of the delay, during which the beeping rate increases.</p> <p>Options: 30 seconds; 60 seconds (default); 90 seconds; 120 seconds, 3 minutes and 4 minutes.</p>
04:EXIT MODE	<p>The "Exit Delay" time can be further adjusted according to your preferred exit route. The control panel provides you with the following "Exit Mode" options:</p> <p>A: "normal" - The exit delay is exactly as defined.</p> <p>B: "restrt+arm home" - Exit delay restarts when the door is reopened during exit delay. If no door was opened during exit delay "AWAY", the control panel will be armed "HOME".</p> <p>C: "restart>reentry" - The exit delay restarts when the door is reopened during exit delay. The restart occurs once only. Restarting the exit delay is helpful if the user re-enters immediately after going out to retrieve an item that he left behind.</p> <p>D: "end by exit" - The exit delay expires (ends) automatically when the exit door is closed even if the defined exit delay time was not completed.</p> <p>Options: normal (default); restrt+arm home; restart>reentry and end by exit.</p> <p>Note: In some PowerMaster 360 variants, this menu is displayed in the Operation Mode only (see section 4.13).</p>
05:QUICK ARM	<p>Define whether or not the user will be allowed to perform quick arming or not. Once quick arming is permitted, the control panel does not request a user code before it arms the system.</p> <p>Options: OFF (default) and ON (default in USA).</p>
06:BYPASS ARM	<p>Define whether or not the user will be allowed to manually bypass individual zones, or allow the system to perform automatic bypassing of open zones during the exit delay (i.e. "force arm"). If a zone is open and "forced arming" is not permitted, the system cannot be armed and "NOT READY" is displayed. If "no bypass" is selected, neither manual bypassing nor force arming is allowed which means that all zones must be secured before arming.</p> <p>Options: no bypass (default); force arm and manual bypass (default in USA).</p> <p>Notes:</p> <ol style="list-style-type: none"> 1. To comply with EN requirements, "manual bypass" must be selected. 2. The option "force arm" is not applicable in the UK. 3. A zone in Soak Test mode that is configured as bypass will trigger a test fail event if the system detects a potential alarm event. 4. There is no limit of reported events when a bypass zone is in Soak Test mode.
07:LATCHKEY ARM	<p>When "ON", a "latchkey" message will be reported by SMS message to users (see Note) upon disarming by a "latchkey user" (users 5-8 or keyfob transmitters 5-8). This mode is useful when parents at work want to be informed of a child's return from school.</p> <p>Options: OFF (default) and ON.</p> <p>Note: To enable the reporting, you must configure the system to report "alrt" events to Private users (Latchkey belongs to the "alerts" group of events). Refer to section 4.6.4 "REPORTED EVENTS" option in both "VOICE REPORT" & "SMS REPORT" menus.</p>

4. PROGRAMMING

Option	Configuration Instructions
08:DISARM OPTION	<p>Certain regulations require that when the system is armed in AWAY mode, it may not be disarmed from the outside of the house (such as by keyfobs) before entering the protected premises and activating an "Entry Delay" zone. To answer this requirement, the PowerMaster 360 provides you with the following configurable options to disarm the system:</p> <p>A: At "any time" (default), the system can be disarmed at all times from all devices.</p> <p>B: During entry delay, the system can be disarmed only using keyfob or prox operated devices ("on entry wrless").</p> <p>C: During entry delay by code, the system can be disarmed only using the Configuration device (PC or mobile) ("entry + away kp.").</p> <p>D: During entry delay, the system can be disarmed using keyfobs or by code using the Configuration device (PC or mobile) ("on entry all.").</p> <p>Note: <i>In some PowerMaster 360 variants, this menu is displayed in the Operation Mode only (see section 4.13).</i></p>
09:ARMING KEY	<p>Determine that, when activated, the Arming Key will arm AWAY or HOME.</p> <p>Options: arm AWAY (default) and arm HOME.</p>

4.5.3 Configuring Zones Functionality

The following table provides you with a detailed description of each option and its configuration settings. To select an option and change its configuration – refer to section 4.5.1.

Option	Configuration Instructions
21:SWINGER STOP	<p>Define the number of times a zone is allowed to initiate an alarm within a single arming/disarming period (including tamper & power failure events of detectors, etc.). If the number of alarms from a specific zone exceeds the programmed number, the control panel automatically bypasses the zone to prevent recurrent siren noise and excessive reporting to the Monitoring Station. The zone will be reactivated upon disarming, or 8 hours after having been bypassed (if the system remains armed).</p> <p>Options: after 1 alarm (default); after 2 alarms (default in USA); after 3 alarms and no stop.</p> <p>Note: <i>When a detector is in Soak Test¹ mode and also set to bypass, Swinger Stop will not prevent the sending of events. This may result in excessive reporting of Soak Fail events.</i></p>
22:CROSS ZONING	<p>Define whether cross zoning will be active "ON" or inactive "OFF" (default). Cross zoning is a method used to counteract false alarms - an alarm will be initiated only when two adjacent zones (zone couples) are violated within a 30-second time window.</p> <p>This feature is active only when the system is armed AWAY and only with respect to the following zone couples: 10+11, 12+13, 14+15.</p> <p>Notes:</p> <ol style="list-style-type: none"><i>1. If one of the two crossed zones is bypassed (see Section 4.5.2), the remaining zone will function independently.</i><i>2. It is recommended that crossed zones will be only zones used for detection of burglary i.e. "Zone Types": Entry/ Exit, Interior, Perimeter and Perimeter follower.</i><i>3. If a cross zone is in Soak Test mode, then each zone of this zone couple functions independently.</i> <p><u>Important!</u> <i>Do not define "cross zoning" to any other zone types such as Fire, Emergency, 24h audible, 24h silent etc.</i></p>

4.5.4 Configuring Alarms & Troubles

The following table provides you with a detailed description of each option and its configuration settings. To select an option and change its configuration – refer to section 4.5.1.

Option	Configuration Instructions
31: PANIC ALARM	<p>Define whether or not the user will be allowed to initiate a Panic Alarm from keypads (by simultaneous pressing the two "Panic Buttons") or keyfobs (by simultaneous pressing the "Away" + "Home" buttons) and whether the alarm will be "silent" (i.e. only reporting of the event) or also audible (i.e. the sirens will also sound).</p> <p>Options: audible (default); silent and disabled.</p>
32: DURESS ALARM (not applicable in UK)	<p>A duress (ambush) alarm message can be sent to the Monitoring Station if the user is forced to disarm the system under violence or menace. To initiate a duress message, the user must disarm the system using a duress code (2580 by default).</p> <p>To change the code, enter the new 4-digit of the new Duress code at the position of the blinking cursor or enter 0000 to disable the duress function and then press OK.</p> <p>Notes: <i>The system does not allow programming a duress code identical to an existing user code.</i></p>
33: INACTIVE ALERT Previously known as "NOT ACTIVE"	<p>If no sensor detects movement in interior zones at least once within the defined time window, an "inactive alert" event is initiated.</p> <p>Define the time window for monitoring the lack of motion.</p> <p>Options: disabled (default); after: 3/6/12/24/48/72 hours</p>
34: TAMPER ALARM	<p>Define whether the Tamper switch protection of all zones and other peripheral devices (except the control panel) are "active" (default) or "not active".</p> <p>Warning! <i>If you select "not active", be aware that no alarm or report will be initiated in case of tampering with any of the system peripheral devices.</i></p>
35: AC FAIL REPR	<p>To avoid nuisance reporting in case of short interruptions in the house of AC power, the system reports an AC Fail message only if the AC power does not resume within a pre-determined time delay.</p> <p>Options: after 5 minute (default), after 30 minute, after 60 minute or after 3 hours.</p> <p>Note: <i>To comply with EN requirements, the time delay must not exceed 60 min.</i></p>
36: CONFIRM ALARM Previously known as "CONFIRM TIME"	<p>If two successive alarm events occur within a specific time window, the system can be configured to report the second alarm event as a "confirmed alarm" (see section 4.6.3 option 61). You can activate this feature and set the respective time window.</p> <p>Options: disable (default in USA); in 30/45/60 (default)/90 minutes</p> <p>Note: <i>In some PowerMaster 360 variants, this menu is displayed in the Operation Mode only (see section 4.13).</i></p>
37: ABORT TIME	<p>The PowerMaster 360 can be configured to provide a delay before reporting an alarm to the Monitoring Station (not applicable to alarms from 24H SILENT and EMERGENCY zones). During this delay period, the siren sounds but the alarm is not reported. If the user disarms the system within the delay time, the alarm is aborted. You can activate the feature and select the "Abort Time" interval.</p> <p>Options: in 00 (default in USA)/15/30 (default)/45/60 seconds; in 2/3/4 minutes</p> <p>Note: <i>In some PowerMaster 360 variants, this menu is displayed in the Operation Mode only (see section 4.13).</i></p>
38: CANCEL ALARM Previously known as "ALARM CANCEL"	<p>The PowerMaster 360 can be configured to provide a "Cancel Alarm" time window that starts upon reporting an alarm to the Monitoring Station. If the user disarms the system within that "cancel alarm" time, a "cancel alarm" message is sent to the Monitoring Station indicating that the alarm was canceled by the user.</p> <p>Options: not active (default in USA); in 1/5 (default)/15/60 minute(s) and in 4 hours.</p>

4. PROGRAMMING

Option	Configuration Instructions
	<p>Notes:</p> <ol style="list-style-type: none"> 1. In some PowerMaster 360 variants, this menu is displayed in the Operation Mode only (see section 4.13). 2. Since the Soak Test zone does not report an alarm event to the Monitoring Station, the PowerMaster 360 will not send a "cancel alarm" message to the Monitoring Station even if disarmed within the Cancel Alarm period.
39:ALARM RESET Previously known as "RESET OPTION"	<p>The PowerMaster 360 provides you with the following configurable options for resetting the alarm condition and rearming the system:</p> <p>By the user as usual - by user (default). By the engineer (installer) by entering and exiting the "Installer Mode", by entering and exiting the Event Log using the Installer Code or by accessing the system remotely via the PowerManage server using the Installer Code (by engineer). For accessing the system via the PowerManage server, see the PowerManage User's Guide.</p> <p>Note: This feature is not applicable in the USA.</p>
40:ABORT FIRE T.	<p>Select the length of time allowed by the system to abort a Fire alarm. The PowerMaster 360 is able to provide an "abort interval" that starts upon detection of a Fire event. During this interval, the buzzer sounds a warning but the siren remains inactive and the alarm is not reported. If the user disarms the system within the allowed abort interval, the alarm is aborted.</p> <p>Options: in 00 (default)/30/60/90 seconds</p>

4.5.5 Configuring Sirens Functionality

The following table provides you with a detailed description of each option and its configuration settings. To select an option and change its configuration – refer to section 4.5.1.

Option	Configuration Instructions
44:SIREN TIME Previously known as "BELL TIME"	<p>Define the period of time the sirens will sound upon alarm.</p> <p>Options: 1/3/4 (default)/8/10/15/20 minute(s).</p> <p>Notes:</p> <ol style="list-style-type: none"> 1. To comply with EN requirements, the "Siren Time" must not exceed 15 minutes. 2. For Canada, the "Siren Time" must be set to 8 minutes.
45:STROBE TIME	<p>Define the length of time the strobe light will flash upon alarm.</p> <p>Options: 5/10/20 (default)/40/60 minutes.</p>

4.5.6 Configuring Audible & Visual User Interface

The following table provides you with a detailed description of each option and its configuration settings. To select an option and change its configuration – refer to section 4.5.1.

Option	Configuration Instructions
53:MEMORY PROMPT	<p>Define whether or not the user will receive "Memory" indication on the Virtual Keypad that an alarm has been activated. By pressing the  button in standby mode, you can view details of the alarm memory.</p> <p>Options: ON (default) and OFF.</p>
54:LOW-BAT ACK	<p>You can activate or deactivate the "Low Battery Acknowledge" requirement from the user whose keyfob's battery is low. For further information, see PowerMaster 360 User's Guide Chapter 6.</p> <p>Options: OFF (default) – acknowledge not needed; ON – acknowledge required.</p>
56:SCREEN SAVER With Partition disabled	<p>The Screen Saver option (when activated) replaces the status display on the virtual keypad with "PowerMaster 360" display if no key is pressed during more than 30 seconds.</p> <p>You can activate the Screen Saver and determine whether the status display will resume following any key press (refresh by Key) or by entering a code (refresh by Code). If refresh by Key is selected, the first pressing of any key (except Fire and Emergency) will produce the status display and the second press will perform the key function. For further information, see the User's Guide, Chapter 1, "Screen Saver Mode".</p> <p>Options: OFF (default); refresh by Code and refresh by Key.</p>

Option	Configuration Instructions
	<p>Notes:</p> <ol style="list-style-type: none"> 1. To comply with EN requirements, "refresh by code" must be selected. 2. For Fire and Emergency keys, the first key press will produce the status display and will also perform the Fire/Emergency function.
56:SCREEN SAVER With Partition enabled	<p>Certain regulations require that the system status display will not be exposed to unauthorized persons. The Screen Saver option (when activated) replaces the system status indication on the Virtual Keypad with idle text if no key is pressed during more than 30 seconds.</p> <p>You can activate the Screen Saver option and determine whether the status display will resume following any key press (Text - by Key) or by entering a code (Text - by Code). If Text by Key is selected, the first pressing of any key (except Fire and Emergency) will produce the status display and the second press will perform the key function. Regarding the Fire and Emergency keys, the first key press will produce the status display and will also perform the Fire/Emergency function.</p> <p>You can also determine that if no key is pressed during more than 30 seconds the date and time will appear on the display. You can determine that normal display will return after pressing the  button followed by entering user code (Clock - by Code) or after pressing any key (Clock - by Key). For further information, see the User's Guide, Chapter 1, "Screen Saver Mode".</p> <p>Options: OFF (default); Text - by code; Text - by Key; Clock - by Code; Clock - by Key.</p> <p>Note:</p> <ol style="list-style-type: none"> 1. To comply with EN requirements, "refresh by code" must be selected. 2. For Fire and Emergency keys, the first key press will produce the status display and will also perform the Fire/Emergency function.

4.5.7 Configuring Jamming and Supervision (Missing device)

The following table provides you with a detailed description of each option and its Options. To select an option and change its setting (configuration) – refer to section 4.5.1.

Option	Configuration Instructions															
61:JAM DETECT	<p>Define whether jamming (continuous interfering transmissions on the radio network) will be detected and reported or not. If any of the jam detection options is selected, the system will not allow arming under jamming conditions. The PowerMaster 360 provides several jam detect and reporting options to comply with the following standards:</p> <p>Note: <i>Jamming is identified by the message "system jammed" displayed on the Virtual Keypad.</i></p> <table border="1"> <thead> <tr> <th>Option</th> <th>Standard</th> <th>Detection and Reporting occurs when:</th> </tr> </thead> <tbody> <tr> <td>UL 20/20</td> <td>USA</td> <td>There is continuous 20 seconds of jamming</td> </tr> <tr> <td>EN 30/60</td> <td>Europe</td> <td>There is an accumulated 30 seconds of jamming within 60 sec.</td> </tr> <tr> <td>Class 6 (30/60)</td> <td>British Standard</td> <td>Like EN (30/60) but the event will be reported only if the jamming duration exceeds 5 minutes.</td> </tr> <tr> <td>disabled</td> <td>(default)</td> <td>No jamming detection and reporting.</td> </tr> </tbody> </table> <p>Notes: <i>To comply with EN requirements, "EN 30/60" must be selected.</i> <i>To comply with UK Class-6 requirements, "class 6 (30/60)" must be selected.</i></p>	Option	Standard	Detection and Reporting occurs when:	UL 20/20	USA	There is continuous 20 seconds of jamming	EN 30/60	Europe	There is an accumulated 30 seconds of jamming within 60 sec.	Class 6 (30/60)	British Standard	Like EN (30/60) but the event will be reported only if the jamming duration exceeds 5 minutes.	disabled	(default)	No jamming detection and reporting.
Option	Standard	Detection and Reporting occurs when:														
UL 20/20	USA	There is continuous 20 seconds of jamming														
EN 30/60	Europe	There is an accumulated 30 seconds of jamming within 60 sec.														
Class 6 (30/60)	British Standard	Like EN (30/60) but the event will be reported only if the jamming duration exceeds 5 minutes.														
disabled	(default)	No jamming detection and reporting.														
62:MISSING REPRT Previously known as "SUPERVISION"	<p>Define the time window for reception of supervision (keep alive) signals from the various wireless peripheral devices. If any device does not report at least once within the selected time window, a "MISSING" alert is initiated.</p> <p>Options: after 1/2/4/8/12 (default) hour(s); and disabled.</p> <p>Note: <i>To comply with EN requirements, 1 hour or 2 hours must be selected.</i></p>															
63:NOT READY	<p>Define that in case of a supervision problem (i.e. a device is "missing" - see "62: MISSING REPRT") whether the system will continue to operate as normal or the system status will become "Not Ready" (upon missing) for as long as the "Missing" trouble exists.</p> <p>Options: normal (default) and if missing dev.</p>															

4. PROGRAMMING

64:MISS/JAM ALRM "EN/UL standards" require that if a supervision (missing) or jamming trouble occurs during AWAY arming, the siren will sound and the event will be reported as a tamper event.
Previously known as "BELL/REP.OPT" Define whether the system will behave according to **EN standard** or as **normal** (default).

Note: To comply with **EN requirements** "EN standard" must be selected.

65:SMOK FAST MIS Determine that If the smoke detector does not report at least once within a time window of 200 seconds, a "MISSING" alert is initiated.

Options: **Disabled** (default) and **Enabled**.

4.5.8 Configuring Miscellaneous Features

The following table provides you with a detailed description of each option and its configuration settings. To select an option and change its configuration – refer to section 4.5.1.

Option	Configuration Instructions
91:USER PERMIT	User Permission enables you to determine whether access to the INSTALLER MODE requires the user's permission or not. If you select enabled , the installer will be able to access the system only through the user menu after the user code has been entered (see section 4.2). Options: disable (default) or enable (default in UK). Note: To comply with EN requirements , "Enable" must be selected.
93:SOAK PERIOD	Define the period of time for the Soak Test. Options: Disable (default), 7 days , 14 days or 21 days . Notes: <ol style="list-style-type: none">1. If set to one of the above pre-defined period of times, to be operational Soak Test mode must also be set to "Enable Test" from the "02:ZONES/DEVICES" menu (see Section 4.4.6).2. If a change is made to the period of time of the Soak Test while the zone is currently being tested, this will restart the Soak Test.3. The start of the Soak Test period is defined in the factory from 9 AM (09:00).

4.6 Communication

4.6.1 General Guidance – "Communication" Flow-Chart & Menu Options

The COMMUNICATION menu enables you to configure and customize the communication and reporting of alarm, troubles and other system events for monitoring companies or private users according to your local requirements and personal preferences. PowerMaster 360 offers a variety of communication means including Cellular GSM, GPRS, EMAIL, MMS or SMS and IP via broadband internet connection.

The "04.COMMUNICATION" menu contains several sub-menu options, each covering a group of configurable features and parameters related to the communication and reporting as follows (see detailed list in Step 3 of the chart below):

Option	Description of Option Features and Parameters	Section
2:GSM/GPRS/SMS	Contains configurable features and parameters related to the Cellular connection of the PowerMaster 360 system.	4.6.2
3:C.S. REPORTING	Contains configurable features and parameters related to Reporting of event messages to Monitoring Stations via cellular or IP broadband communication.	4.6.3
4:PRIVATE REPORT	Contains configurable features and parameters related to Reporting event messages to Private Users via email, MMS or SMS.	4.6.4
5:MOTION CAMERA	Contains configurable features and parameters related to Motion Cameras for Video Alarm Verification.	4.6.5
6:UP/DOWNLOAD	Contains configurable connection information, access permission and security codes related to the Upload/Download procedures via GPRS.	4.6.6
7:BROADBAND ¹	Contains DHCP Client settings, enables to enter LAN parameters, to reset broadband module and to enter LAN parameters.	4.6.7

To enter the "04.COMMUNICATION" menu and to select and configure an option, proceed as follows:

Step 1	Step 2	Step 3	Step 4
Select "COMMUNICATION"	Select Communication Sub-menu option	Select the "Communication" Parameter you wish to configure	
INSTALLER MODE ↓ 04.COMMUNICATION	2:GSM/GPRS/SMS ↓ 3:C.S. REPORTING ↓ (*) These options are available only to the "Master Installer"	SMS REPORT GPRS APN GPRS USERNAME SIM PIN CODE 01:REPORT EVENTS * 02:1st RPRT CHAN 05:DUAL REPORT 11:RCVR1 ACCOUNT * 12:RCVR2 ACCOUNT * 21:IP RCVR 1 * 22:IP RCVR 2 * 26:SMS RCVR 1 * 27:SMS RCVR 2 *	GPRS PASSWORD NETWORK ROAMING GPRS ALWAYS ON GSM KEEP ALIVE TRANS. PROTOCOL 47:GSM RETRIES 48:BB IP RETRIES 51: AUTO-TST LOOP 52:AUTO-TST TIME 53:COM.FAIL RPRT →GSM/GPRS FAIL 61:RPRT CNF ALRM 62:RECENT CLOSE * 63:ZONE RESTORE 64:SYST.INACTIVE 66:24H ZONE RPRT
	4:PRIVATE REPORT ↓	SMS REPORT →REPORTED EVENTS →1st SMS tel# →2nd SMS tel# →3rd SMS tel# →4th SMS tel# SMS/MMS BY SRVR	EMAIL BY SERVER →1st E-MAIL →2nd E-MAIL →3rd E-MAIL →4th E-MAIL
			See 4.6.2 4.6.3 4.6.4 See also User's Guide Chap. 4 Section B.12

¹ The name of the product is PowerLink3 IP Communicator

4. PROGRAMMING

Step 1	Step 2	Step 3	Step 4	
Select "COMMUNICATION"	Select Communication Sub-menu option	Select the " Communication " Parameter you wish to configure		
		→1st SMS/MMS →2nd SMS/MMS →3rd SMS/MMS →4th SMS/MMS	See	
	5:MOTION CAMERA ↓	VIEW ON DEMAND VIEW TIME WINDOW VIEW OTHER ALARM	4.6.5	
	6:UP/DOWNLOAD ↓	UP/DOWNLOAD PARAM →Remote access →Mast. UL/DL code →Inst. UL/DL code →UL/DL Modes	GPRS UP/DOWNLOAD →Panel SIM Tel. # →1st caller ID# →2nd caller ID#	4.6.6
	7:BROADBAND ¹	DHCP Client Manual IP PLNK curr.params →Curr.IP address →Curr.subnet mask →Current Gateway	RESET MODULE	4.6.7

4.6.2 Configuring GSM-GPRS (IP) - SMS Cellular Connection

The GSM/GPRS module is capable of communicating with the Monitoring station receiver by GPRS or SMS Channels. The GPRS channel is always enabled. If fails, the GPRS module will try to communicate via SMS.

04:COMMUNICATION ... 2:GSM/GPRS/SMS ... MENU you wish

Enter "2:GSM/GPRS/SMS", select the menu you wish to configure (see guidance above and in section 4.6.1), then refer to the table below which provides you with detailed explanations and configuration instructions for each option.

Option	Configuration Instructions
SMS REPORT	Define whether the system will report events to the Monitoring Stations' SMS receivers via the SMS Channel. For further information, see section 4.6.3 options 26 & 27. Options: disable (default); enable .
GPRS APN	Enter the name of the APN Access Point used for the internet settings for the GPRS (up to 40 digits string). Note: To enter the APN Access Point, use the " String Editor " in section 4.8.1.
GPRS USERNAME	Enter the Username of the APN used for GPRS communications (up to 30 digits string). Note: To enter the Username, use the " String Editor " in section 4.8.1.
SIM PIN CODE	Enter the PIN code of the SIM card installed in the GSM module (up to 8 numerical digits). Note: To enter the numerical PIN code, use the numerical keyboard.
GPRS PASSWORD	Enter the Password of the APN used for GPRS communications (up to 16 digits string). Note: To enter the Password, use the " String Editor " in section 4.8.1.

¹ The name of the product is PowerLink3 IP Communicator

NETWORK ROAMING

Previously known as "FORCE HOME NTWK"

You can force the SIM card to use only its "Home Network" and disable it from roaming to other networks in case the Home Network cannot be found.

Options: **roam disable**; **roam enable** (default).

GPRS ALWAYS ON

Previously known as "SESSION TIMEOUT"

Define whether the control panel will stay continuously connected "**enabled**", via GPRS communication, or disconnect "**disabled**" (default), after each report session.

GSM KEEP ALIVE

Some GSM Service providers tend to disconnect the GSM connection if the user has not initiated any outgoing telephone calls during the last 28 days. To prevent from disconnecting the GSM connection, you can configure the system to generate a "**keep alive**" GSM call **every 28 days** sending a test message either to the first SMS number (if exists) or alternatively first private telephone number.

Options: **Disable** (default) or **Every 28 days**.

TRANS. PROTOCOL

Select the IP protocol used to transfer data over the internet/GPRS.

Options: **TCP** (default); or **UDP**.

4.6.3 Configuring Events Reporting to Monitoring Stations

The PowerMaster 360 control panel is designed to report alarm, alerts, troubles and other events and messages to two Monitoring Stations C.S.1 and C.S.2 via Cellular i.e. GPRS (IP) & SMS or Broadband IP communications channels. In this section you configure and define all parameters and features required for the reporting of the event messages to Monitoring Stations such as:

- The events reported to each of the two Monitoring Stations C.S.1 and C.S.2 and corresponding backups.
- The communication means (channel) used for the reporting and the backup means (channel) in case of failure.
- The customer's (subscriber) account number(s) to be reported to each Monitoring Station.
- The IP addresses, SMS numbers and reporting formats of the corresponding alarm receivers at the two Monitoring Stations C.S.1 and C.S.2 and the number of reporting retry attempts in case of failure to report.
- The communication Auto Tests and communication Fail reports.
- The reporting of certain system function events such as "Confirmed Alarm", "Recent Close", "Zone Restore" and "System Not-Used".

04:COMMUNICATION   ...  3:C.S.REPORTING   ...  MENU you wish 

Enter "3:C.S.REPORTING", select the menu you wish to configure (see guidance above and in section 4.6.1), then refer to the table below which provides you with detailed explanations and configuration instructions for each option.

Option	Configuration Instructions												
01:REPORT EVENTS	<p>Define which events (i.e. Alarms (alm); Open/close (o/c); Alerts (alrt); All events (all); Maintenance and Troubles) will be reported to the Monitoring Stations.</p> <p>The minus (-) symbol means "less/except" e.g. all(-alrt) means all events except alerts.</p> <p>The asterisk (*) is a separator between events reported to Monitoring Station 1 (C.S.1) and events reported to Monitoring Station 2 (C.S.2). For detailed and more complete explanation see the "Event Reporting Chart" at the end of this section.</p> <table border="0"> <tr> <td>Options:</td> <td>all-o/c* backup (default)</td> <td>all-o/c*o/c</td> <td>disable report</td> </tr> <tr> <td></td> <td>all *all</td> <td>all(-alrt)*alrt</td> <td>all *backup</td> </tr> <tr> <td></td> <td>all-o/c*all-o/c</td> <td>alm*all(-alm)</td> <td></td> </tr> </table> <p>Note: Alarm events (alm) have highest priority and Alert events (alrt) have lowest priority.</p>	Options:	all-o/c* backup (default)	all-o/c*o/c	disable report		all *all	all(-alrt)*alrt	all *backup		all-o/c*all-o/c	alm*all(-alm)	
Options:	all-o/c* backup (default)	all-o/c*o/c	disable report										
	all *all	all(-alrt)*alrt	all *backup										
	all-o/c*all-o/c	alm*all(-alm)											

02:1st RPRT CHAN

If the system is equipped also with Cellular communicators, you must define which of the communicating channels (i.e. Cellular or Broadband) the system will use as the main channel (i.e. 1st priority) for reporting event messages to Monitoring Stations.

Enter the "1st RPRT CHAN"; option and define which of the communication channels the system will use as the main reporting channel.

Options: **broadband first** (default); **disable**; and **cellular first**.

Important: If the selected main reporting channel fails, the system will use the other communication channel to report event messages to Monitoring Stations. **If none is selected, the reporting to Monitoring Stations will be disabled.**

4. PROGRAMMING

Option	Configuration Instructions																								
05:DUAL REPORT	Define whether or not to report events using broadband and cellular communication channels. Options: disable (default); broadband & cell .																								
11:RCVR1 ACCOUNT 12:RCVR2 ACCOUNT	Enter the respective 1 st Account (subscriber) number (11:RCVR 1 ACCOUNT) that will identify your specific alarm system to the 1 st Monitoring Station (designated as RCVR1 or RCV1) and a 2 nd Account (subscriber) number (12:RCVR 2 ACCOUNT) that will identify the system to the 2 nd Monitoring Station (designated as RCVR2 or RCV2). Each of the Account numbers consists of 6 hexadecimal digits. To enter Hexadecimal digits, use the following table:																								
Master Installer only	<table border="1"> <thead> <tr> <th></th> <th colspan="7">Entering Hexadecimal Digits</th> </tr> <tr> <th>Digit</th> <th>0....9</th> <th>A</th> <th>B</th> <th>C</th> <th>D</th> <th>E</th> <th>F</th> </tr> </thead> <tbody> <tr> <th>Keying</th> <td>0....9</td> <td>[#]→[0]</td> <td>[#]→[1]</td> <td>[#]→[2]</td> <td>[#]→[3]</td> <td>[#]→[4]</td> <td>[#]→[5]</td> </tr> </tbody> </table>		Entering Hexadecimal Digits							Digit	0....9	A	B	C	D	E	F	Keying	0....9	[#]→[0]	[#]→[1]	[#]→[2]	[#]→[3]	[#]→[4]	[#]→[5]
	Entering Hexadecimal Digits																								
Digit	0....9	A	B	C	D	E	F																		
Keying	0....9	[#]→[0]	[#]→[1]	[#]→[2]	[#]→[3]	[#]→[4]	[#]→[5]																		
21:IP RCVR 1 22:IP RCVR 2	The PowerMaster 360 can be programmed to report the event messages defined in Report Events option (option 01) to two IP Receivers, Visonic PowerManage model. IP reporting can be performed via GPRS (IP) channel using SIA IP format or via Broadband IP channel using SIA IP. Enter the two IP addresses (000.000.000.000) of the IP Receiver 1 located at the 1 st Monitoring Station (21:IP RCVR 1) and IP Receiver 2 located at the 2 nd Monitoring Station (22:IP RCVR 2).																								
Master Installer only																									
26:SMS RCVR 1 27:SMS RCVR 2	If equipped with GSM module, the PowerMaster 360 can be programmed to report the event messages defined in Report Events option (option 01) to two SMS Receivers via the GSM SMS channel using a special SMS text format. For further details concerning the SMS text format please contact Visonic. Enter the two telephone numbers (including area code – maximum 16 digits).of the SMS Receiver 1 located at the 1 st Monitoring Station (26:SMS RCVR 1) and SMS Receiver 2 located at the 2 nd Monitoring Station (27:SMS RCVR 2).																								
Master Installer only	Note: To enter the international prefix (+) at the 1 st digit – key-in [#]→[1].																								
47:GSM RETRIES	Define the number of times the system will retry to report to the Monitoring Station in case of failure to report via the cellular connection - GPRS (IP) and SMS. Options: 2 attempts; 4 attempts (default); 8 attempts; 12 attempts and 16 attempts .																								
48:BB IP RETRIES	Define the number of times the system will retry to report to the Monitoring Station in case of failure to report via the Broadband Module connection. Options: 2 attempts; 4 attempts (default); 8 attempts; 12 attempts and 16 attempts .																								
51: AUTO-TST LOOP	To verify a proper communication channel, the PowerMaster 360 can be configured to send a test event to the Monitoring Station periodically. You can set the interval between the consecutive test events or disable the automatic sending of this event entirely. If the interval is set for every one day or more then the exact hour of reporting can be selected with option 52. Options: test OFF (default); every 1/2/5/7/14/30 day(s) ; and every 5 hours .																								
52:AUTO TST TIME	Enter the exact time (auto test time) during the day at which the Auto Test message (if enabled in option 51) will be sent to the Monitoring Station. Note: If the AM/PM format is used, you can set the "AM" digit with the * button and the "PM" digit with the button.																								
53:COM.FAIL RPRT → GSM/GPRS FAIL ↑ (Return)	Determine whether a failure in the system communication channel i.e. GSM/GPRS will be reported or not and the time delay between detection of the failure and reporting of the failure event to the Monitoring Station. A trouble event (i.e. "GSM line fail") will be respectively stored in the event log. Options: after 2/5/15/30 min and do not report (default).																								
Previously known as "LINE FAIL REPORT"																									

Option	Configuration Instructions
61:RPRT CNF ALRM	Define whether the system will report whenever 2 or more events (confirmed alarm) occur during a specific period or enable the report and bypass the detector. Options: rprr disabled (default), rprr ena+bypass and rprr enabled Note: In some PowerMaster 360 variants, this menu is displayed in the Operation Mode only.
62:RECENT CLOSE	False alarms may occur if users do not exit the premises within the exit delay period, resulting in a false alarm a short time later. In such cases, inform the Monitoring Station that the alarm occurred shortly after the system was armed (this event is known as "Recent Close"). The report enabled option sends a "recent closing" report to the Monitoring Station if an alarm occurs within 2 minutes from the end of the exit delay. Options: report disabled (default) and report enabled
63:ZONE RESTORE	Some Monitoring Stations require that following an alarm event from a specific zone, the system will also report when the alarming zone has restored to normal. Options: report enabled (default) and report disabled
64:SYST.INACTIVE	The PowerMaster 360 can report a "System Inactive" event message (CID event 654) to the Monitoring Station if the system is not used (i.e. armed) during a predefined time period. Options: report disabled (default); after 7/14/30/90 days .
66:24H ZONE RPRT Applicable in UK only	Define whether 24 hour (silent and audible) zones will function as normal 24 hour zones or as panic zones. Options: audibl as panic ; silent as panic ; both as panic ; and both burglary (default).

Event Reporting Chart

To simplify the configuration of reporting system events to Monitoring Stations, the event messages are divided into 4 Event Groups as described in the following table below: Due to lack of space in the display, the following abbreviations are used **alm**, **alrt**, **o/c** and **all** (i.e. all events).

Event Group	Abbr.	Events Messages Reported
Alarms	alm	Fire, CO, Burglary, Panic, Tamper
Open/close	o/c	Arming AWAY, Arming HOME, Disarming
Alerts	alrt	No-activity, Emergency, Latchkey
Trouble	-	All other Trouble events not indicated above, e.g. Missing, Jamming, Communication Fail, Low Battery, AC failure etc.

Note: "Alarms" group has the highest priority and "Alerts" group has the lowest priority.

The PowerMaster 360 allows you also to select which event groups will be reported to each of the two Monitoring Stations. The table below describes the available reporting options. The minus (-) symbol means "but/less/except" e.g. **all(-alrt)** means **all** events except **alrts**. The asterisk (*) is a separator between event messages reported to **Monitoring Station 1** (C.S.1) and event messages reported to **Monitoring Station 2** (C.S.2).

Available Reporting Options	Events Reported to C.S. 1	Events reported to C.S. 2
" all * backup "	All	All, only if C.S.1 does not respond
" all-o/c * backup "	All but open/close	All but open/close, only if C.S. 1 does not respond
" all * all "	All	All
" all-o/c * all-o/c "	All but open/close	All but open/close
" all-o/c * o/c "	All but open/close	Open/close
" all(-alrt) * alrt "	All but alerts	Alerts
" alm * all(-alarm) "	Alarms	All but alarms
" disable report "	None	None

Note: "all" means that all 5 Groups are reported including Trouble messages - sensor / system low battery, sensor inactivity, power failure, jamming, communication failure etc.

4. PROGRAMMING

4.6.4 Configuring Events Reporting to Private Users

The PowerMaster 360 system can be programmed to send various SMS event notifications such as alarm, arming or trouble events, if a GSM option is installed. The system can send the messages also to 4 emails, MMS and SMS telephone numbers via the server. These reports can be programmed either instead of or in addition to the reports transmitted to the monitoring company. In this section you configure:

- The specific events you wish the system to report.
- The 1st, 2nd, 3rd, and 4th SMS numbers of the private subscribers.
- Event notification messages to be sent to 1st, 2nd, 3rd, and 4th private emails and private MMS and SMS telephone numbers via the server.

To select and configure an option follow the instructions below. Additional guidance is provided in section 4.6.1.

04:COMMUNICATION   ...  4:PRIVATE REPORT   ...  MENU you wish 

The "4:PRIVATE REPORT" menus and sub-menus configuration is shown in the table in section 4.6.1. For a detailed description of the menus options, refer to the User's Guide Chapter 4, section B.12.

4.6.5 Configuring Motion Cameras for Visual Alarm Verification

The PowerMaster 360 can communicate to Monitoring Stations (equipped with Visonic PowerManage server) with image clips captured by Motion Cameras (models Next CAM PG2, Next-K9 CAM PG2 and TOWER CAM PG2). The Monitoring Station can use the video clips for verification of Burglary alarms detected by the Motion Cameras. The system can be configured to capture image clips also upon occurrence of Non-Burglary alarms (i.e. Fire, Duress, Emergency and Panic). The server can then forward the images to the management computer of the Monitoring Station or to 4 private emails and/or 4 mobile phones by MMS images.

In addition, the Monitoring Station can log into the PowerManage server and request the system to provide image clips "On Demand" and to forward them as defined in the PowerManage application. To protect customers' privacy, the PowerMaster 360 can be customized to enable the "On Demand View" only during specific system modes (i.e. Disarm, Home and Away) and also to a specific time window following an alarm event.

04:COMMUNICATION   ...  5:MOTION CAMERAS   ...  MENU you wish 

Enter "5:MOTION CAMERAS", select the menu you wish to configure (see guidance above and in section 4.6.1), then refer to the table below which provides you with detailed configuration instructions.

Option	Configuration Instructions
VIEW ON DEMAND	By enabling the "On Demand View", you can determine during which arming modes (system states) the "On Demand View" will be permitted. In the next option "VIEW TIME WINDOW" you can determine when, during the permitted arming modes, the "On Demand View" will be enabled. Options: disabled (default); in all modes ; in AWAY only ; in HOME only ; in HOME & AWAY ; DISARM & AWAY ; DISARM & HOME ; and in DISARM only .
VIEW TIME WINDOW VIEW TIME WINDOW menu appears only if VIEW ON DEMAND was enabled	If the "On Demand View" is enabled in the previous option, you can further determine whether the "On Demand View" will be possible at any time during the selected arming modes (i.e. "Always") or restricted only to a specific limited time window that follows an alarm event. Options: Always (default); Alarm + 5 min. ; Alarm + 15 min. ; Alarm + 1 hour
VIEW OTHER ALARM	Define whether the system will capture and forward image clips also upon occurrence of Non-Burglary alarms (i.e. Fire, Duress, Emergency and panic). Options: Enable (default); Disable .
KIDS COME HOME	Define that upon PIR-camera detection, the system will send up to 4 images to a 3rd party server if the system is disarmed via keypad or proximity tag by latchkey users 5 to 8 and only when the system was in Entry Delay or the Abort Time was enabled. Options: Enable ; Disable (default). Note: At least one PIR camera must be defined as one of the following zone types: Perim-Follow / Inter-Follow / Exit/Entry 1 / Exit/Entry 2.
UPLOAD FILM	Define whether to enable / disable the sending of images to the PowerManage server. Options: Enable (default); Disable .

4.6.6 Configuring Upload / Download Remote Programming Access Permission

Using a PC, the PowerMaster 360 can be configured (by upload/download) either locally or from remote via GPRS cellular communication.

Local programming can be performed by directly connecting the computer to the panel's USB port using the Remote Programmer PC Software.

Remote programming via GPRS is performed using a Visonic PowerManage server and related Remote Programmer PC software. The PowerManage server calls from a cellular modem to the Panel's SIM card number. The panel checks the caller ID and if identical with any of the two callers ID 1 or 2 programmed in the "GPRS UP/DOWNLOAD" menu (see table below), the panel initiates a GPRS connection with the respective IP Receiver 1 or 2 (as configured in section 4.6.3 options 21 & 22). When connection is established, the monitoring company can perform the upload/download procedure via the established secured GPRS connection. For further information refer to the PowerManage User's Guide.

In this section you can configure the access permissions (i.e. security codes and identification) and determine the functionality of the upload/download procedures via GPRS channel.

04:COMMUNICATION ... 6:UP/DOWNLOAD ... MENU you wish

Enter "6:UP/DOWNLOAD", select the menu to configure (see guidance above and in section 4.6.1), then refer to the table below for configuration instructions.

Option	Configuration Instructions
UP/DOWNLOAD PARAM	Configure the Upload/Download functionality. The functionality is determined through a sub-menu of the "UP/DOWNLOAD" option as shown below. <u>To program:</u> Press to enter the "UP/DOWNLOAD" sub menu and then select and configure each of the sub-menu options as shown below. When done, press to return.
→Remote access	Enable or disable the remote access to the system. If disabled, the system cannot be accessed remotely thereby inhibiting the Upload/Download and the Remote Control via GSM analog communication channel (see Chapter 5 in the User's Guide). Options: enabled (default); disabled .
→Mast. UL/DL code	Enter the 4-digit password (Master Installer download code) code that will allow the Master Installer to access the system remotely and upload/download data to the PowerMaster 360 panel. Note: "0000" is not a valid code and must not be used.
→Inst. UL/DL code	Enter the 4-digit password (Installer download code) code that will allow the Installer to access the system from remote and upload or download data into the PowerMaster 360 panel. Notes: 1. "0000" is not a valid code and must not be used. 2. The installer can configure via UL/DL only the options he is authorized to configure from the control panel.
→UL/DL modes	Define whether the downloading/uploading can be performed in Disarm mode (state) only or in all modes (i.e. Away, Home & Disarm). Options: in all modes (default) or in DISARM only .
(Return)	
GPRS UP/DOWNLOAD	Configure the Upload/Download functionality via GPRS. The functionality is determined through a sub-menu of the "GPRS UP/DOWNLOAD" option as shown below. <u>To program:</u> Press to enter the "GPRS UP/DOWNLOAD" sub menu and then select and configure each of the sub-menu options as shown below. When done, press to return.
→ Panel SIM Tel.# (Previously known as "My SIM Tel.#")	Enter the PowerMaster 360 SIM card telephone number. The PowerManage server at the Monitoring Station sends an SMS or voice message to this number for the panel to call back the PowerManage server via GPRS for initiating the uploading / downloading process. Enter the SIM card telephone number of the panel's GSM module.

4. PROGRAMMING

Option	Configuration Instructions
→ 1st caller ID#	Enter the " Caller ID " (i.e. telephone number) from which Monitoring Station #1 (C.S.1) / Monitoring Station #2 (C.S.2) calls the control panel for initiating the Up/Download process. If the sender's Caller ID matches with the "1 st caller ID#" / "2 nd caller ID#", the PowerMaster 360 will call back the PowerManage server using " IP RCVR 1 " / " IP RCVR 2 " address as configured in Section 4.6.3, options 21 and 22.
→ 2nd caller ID#	
Note: Caller ID#1/ID#2 must contain at least 6 digits otherwise the process will not work.	

 (Return)

4.6.7 Broadband¹

Note: If the Broadband Module is not registered to the PowerMaster 360, the menu "**7:BROADBAND**" will not be displayed.

In this section you can configure how to obtain an IP address, enter LAN parameters and reset broadband module settings. In addition, the "PLNK curr.params" menu enables reading the current IP addresses of the PowerLink for support purposes only.

04:COMMUNICATION   ...  7:BROADBAND   ...  MENU you wish 

Enter "**7:BROADBAND**", select the menu to configure (see guidance above and in section 4.6.1), then refer to the table below for configuration instructions.

Option	Configuration Instructions
DHCP Client	Define whether to obtain an IP address automatically using a DHCP server or to enter an IP address manually. Options: disable ; enable (default).
Manual IP	Manually enter LAN parameters. Note: This menu will appear only if DHCP Client is disabled.
PLNK curr.params	Displays the current IP addresses of the PowerLink.
→Curr.IP address	Displays the current PowerLink IP address.
→Curr.subnet mask	Displays the current PowerLink subnet mask.
→Current Gateway	Displays the current PowerLink default gateway.
RESET MODULE	Determine whether to reset the broadband module (reboot).

¹ The name of the product is PowerLink3 IP Communicator

4.7 Custom Names

4.7.1 Custom Zone Names

During the device enrollment process you also define the Location name where the device is installed. The location name is selected from a Location List of Custom names - see Section 4.4.2, Part B, for Location List and instructions. Define the custom location names according to your specific needs and use them during device enrollment.

To define the Custom Location names, follow the instructions below. Additional guidance is provided in section 4.2.

06:CUSTOM NAMES   ...  CUST.ZONES NAME 





Enter "**CUST.ZONES NAME**" (see guidance above), then refer to the table below which provides you with detailed explanations and programming instructions to edit the desired custom location.

Note: The following custom names can be edited: Master Bdrm, Office, Upstairs, Utility Room, Yard, Custom 1, Custom 2, Custom 3, Custom 4 and Custom 5.

Configuration Instructions

Enter the Custom Location names you wish to edit.

























To edit:

Press  to enter the "**CUST. ZONES NAME**" sub menu and then press  again to select the Location # you wish to edit, for example "**TEXT LOC. #01**" – the display alternates with the current Custom name, for example, "**Master Bdrm**". To change the name, at the blinking cursor, enter the Location name you wish and at the end, press  to confirm. When done, press  to return.

Note: To enter the Location name use the "String Editor" below.

IMPORTANT! The editing of a custom zone name automatically deletes the original text.

PowerMaster 360 String Editor

Key	String Editor Functionality
 	',' '0'
	',' ',' '1'
	'a', 'A', 'b', 'B', 'c', 'C', '2'
	'd', 'D', 'e', 'E', 'f', 'F', '3'
	'g', 'G', 'h', 'H', 'i', 'I', '4'
	'j', 'J', 'k', 'K', 'l', 'L', '5'
	'm', 'M', 'n', 'N', 'o', 'O', '6'
	'p', 'P', 'q', 'Q', 'r', 'R', 's', 'S', '7'
 	't', 'T', 'u', 'U', 'v', 'V', '8'
	'w', 'W', 'x', 'X', 'y', 'Y', 'z', 'Z', '9'
 	!, #, %, &, ', *, +, -, /, =, ^, @, _ , " , :
	Moves the digits cursor from left to right .
	Moves the digits cursor from right to left .
 	Changes between lowercase letters (a,b,c...z), uppercase letters (A,B,C...Z) and numbers (1,2,3).
 	Clears a single digit of the string by cursor.
 	Clears a single digit of the string to the left of cursor.
	Confirms and saves the edited string and reverts to previous menu.
	Exiting the edit screen and moves one level up to previous or top menu without saving the edit string.
	Exiting the edit screen and moves to the "<OK> TO EXIT" exit screen without saving the edit string.

4. PROGRAMMING

4.8 Diagnostics

4.8.1 General Guidance – "Diagnostics" Flow-Chart & Menu Options

The DIAGNOSTICS menu enables you to test your system and to verify proper operation of your PowerMaster 360 panel, wireless devices attached to it and the communication (GSM/GPRS/SIM) modules.













IMPORTANT! *Reliable reception must be assured during the initial testing and also throughout subsequent system maintenance. A device should not be installed in location where signal strength is "poor". If you get "poor" signal strength from a certain device, simply re-locate it and re-test until a "good" or "strong" signal strength is received. This principle should be followed throughout the diagnostic test procedure.*

The diagnostic test process is shown below.

The "07.DIAGNOSTICS" menu contains several sub-menu options, each covering a group of configurable features and parameters related to the communication and reporting as follows (see the list in Step 3 of the chart below):

Option	Description of Option Features and Parameters	Section
WL DEVICES	Describes how to test the devices attached to the PowerMaster 360 panel, review devices' status and RF signal status. You can test all devices, test single device, review devices status and review RF problems, in case of any.	4.8.2
GSM/GPRS	Describes how to test the GSM/GPRS communication module.	4.8.3
SIM NUMBER TEST	Tests the SIM number to ensure correct entry of the SIM number in the control panel.	4.8.4
BROADBAND MODULE¹	Enables to test the communication of the Broadband Module with the PowerManage server.	4.8.5

To enter the "07.DIAGNOSTICS" menu and to select and configure an option, proceed as follows:

Step 1	Step 2	Step 3	Step 4
Select "07.DIAGNOSTICS"	Select sub-menu option	Select the diagnostics you want to perform	
 INSTALLER MODE  07.DIAGNOSTICS	 WL DEVICES	 TEST ALL DEVICES SHOW ALL DEVICES SHOW RF PROBLEMS TEST ONE DEVICE	 Contact sensors Motion sensors Repeaters
	 GSM/GPRS		
	 SIM NUMBER TEST¹	 Tst by IP RCVR 1 Tst by IP RCVR 2	 SIM# verified
	 BROADBAND MODULE²	 PLEASE WAIT...	 Unit is OK

4.8.2 Testing Wireless Devices

The PowerMaster 360 enables to test the wireless devices attached to the panel. You can test all devices, one device at a time, display devices' status and review RF problems, in case of any.

07:DIAGNOSTICS   ...  **WL DEVICES**   ...  **MENU you wish** 

Enter the "WL DEVICES" menu, select the type of test you wish to perform (see guidance above and in section 4.8.1), then refer to the table below which provides you with detailed explanations for each option.

¹ The name of the product is PowerLink3 IP Communicator

Option	Instructions
TEST ALL DEVICES	<p>You can test all wall-mounted devices automatically, one after the other, after which the installer tests the other devices in the following order: vanishing magnetic contact devices, keyfobs and then panic buttons.</p> <p>While in "TEST ALL DEVICES", press OK to initiate the test. The following screen will appear: "TESTING Xxx NNN", where "Xxx" indicates the type of device and "NNN" indicates the number of enrolled devices in the panel that have not been tested yet. This number automatically drops one count for every tested device.</p> <p>Pressing any key during the testing process will open the following options:</p> <ol style="list-style-type: none"> Press ▶▶ to jump to the next device group. For example, from wall-mounted devices to keyfobs. Press OK to continue the testing process Press 🔒 to exit the test process. <p>When all wall-mounted devices have completed the test procedure, you can test vanishing magnetic contact devices.</p> <p>While in the vanishing test process, indicated by the corresponding display, for example, "TEST VANISH NNN", momentarily open the door or window.</p> <p>When all vanishing magnetic contact devices have been tested, you can test keyfobs. While in the keyfobs test process, indicated by the corresponding display, for example, "TEST KEYFOBS NN", press any key of the selected device to initiate the test.</p> <p>When all keyfobs have been tested, you can test panic buttons. While in the panic button test process, indicated by the corresponding display, for example, "TEST PANIC BT. NN", press a button on the pendant.</p> <p>At the end of the test process, the panel will present the following: "SHOW ALL DEVICES". Press OK to view devices' status.</p> <p>Note: Refer to "SHOW ALL DEVICES" section below for further information on device status.</p>
TEST ONE DEVICE →CONTACT SENSORS →MOTION SENSORS →GLASSBREAK SENS. →SHOCK SENSORS →SMOKE SENSORS →CO SENSORS →GAS SENSORS →FLOOD SENSORS →TEMPERATURE SENS. →KEYFOBS →PANIC BUTTONS →KEYPADS →SIRENS →REPEATERS	<p>You can select a specific device group you wish to test, for example, Motion Sensors.</p> <p>Press OK to enter the "TEST ONE DEVICE" sub menu and use ▶▶ to scroll through the device families. Press OK to enter the <device family> sub menu, for example: "MOTION SENSORS".</p> <p>Note: If there is no enrolled device, "NO EXISTING DEV." will be displayed.</p> <p>The following screens will then appear: "Xxx:<device name>" ↶ "<location>"</p> <p>Where Xxx indicates the device number. You can now select a specific device.</p> <p>Press OK to test the selected device. The following screen will appear: "TESTING Xxx 001".</p> <p>While in the keyfobs, panic button or vanishing magnetic contact test process, indicated by the corresponding display, for example, "Xxx ACTIVATE NOW", press any key of the selected keyfob or panic button, or momentarily open the door or window to initiate the test.</p> <p>At the end of the test process, the panel will present the devices' status: "Xxx: 24hr: <status>"¹ ↶ "Xxx: NOW: <status>"¹.</p> <p>Note: Refer to "SHOW ALL DEVICES" section for further information on device status.</p>
SHOW ALL DEVICES	<p>You can view the devices status.</p> <p>Note: This option is available only after testing process was done.</p> <p>Press OK to view the devices' status.</p> <p>The following screens will appear: "Xxx: 24hr: <status>"¹ ↶ "Xxx: NOW: <status>"¹</p> <p>Use ▶▶ to scroll between the device's families.</p>

¹ The signal strength indications are as follows: "STRONG"; "GOOD"; "POOR"; "1-WAY" (the device operates in 1-way mode or, the "NOW" communication test failed); "NOT TST" (results are shown without any performed test); "NOT NET" [device is not networked (not fully enrolled)]; "NONE" (keyfob 24Hr result); or "EARLY" (result of the last 24Hrs without statistics).

4. PROGRAMMING

Option	Instructions
	To view additional information of the selected device, press OK . The following screens will appear: " Xxx <device name> " ↩ " <location> ". If the control panel receives information via a repeater, it will be displayed as follows: " Xxx <device name> " ↩ " <location> " ↩ " RPx:Via Repeater " ↩
SHOW RF PROBLEMS	You can view only the devices which have RF problems. Note: <i>This option is available only after testing process was done.</i> Press OK to view the devices' status. The following screens will appear: " Xxx: 24hr: <status> " ↩ " Xxx: NOW: <status> " Use ▶▶ to scroll between the device's families. To view additional information of the selected device, press OK . The following screens will appear: " Xxx <device name> " ↩ " <location> ". If the control panel receives information via a repeater, it will be displayed as follows: " Xxx <device name> " ↩ " <location> " ↩ " RPx:Via Repeater " ↩
<OK> TO END	Select to terminate the diagnostics test.

4.8.3 Testing the GSM module

The PowerMaster 360 enables to test the panel's integrated GSM module.

07:DIAGNOSTICS **OK** ▶▶ ... ▶▶ GSM/GPRS **OK** Please wait...

Enter the "GSM/GPRS" menu, and press **OK** to initiate the GSM diagnostic test. Upon test completion, the PowerMaster 360 will present the test result.

The following table presents the test result messages.

Message	Description
Unit is OK	GSM / GPRS is functioning correctly
GSM comm. loss	GSM/GPRS module does not communicate with the Panel
Pin code fail	Missing or wrong PIN code. (Only if SIM card PIN code is enabled.)
GSM net. fail	Unit failed with registration to local GSM network.
SIM card fail	SIM not installed or SIM card failure.
GSM not detected	GSM auto enroll failed to detect GSM/GPRS module.
No GPRS service	The SIM card does not have the GPRS service enabled.
GPRS conn. fail	Local GPRS network is not available or, wrong setting to GPRS APN, user and/or password.
Srvr unavailable	PowerManage receiver cannot be reached – Check the Server IP
IP not defined	Server IP #1 and #2 are not configured.
APN not defined	APN is not configured.
SIM card locked	After entering a wrong PIN code 3 consecutive times the SIM is locked. To unlock it enter a PUK number. The PUK number cannot be entered by the control panel.
Denied by server	PowerManage denies the connection request. Check that the panel is registered to PowerManage.

4.8.4 Testing the SIM Number

The PowerMaster 360 enables to test the SIM number to ensure the SIM number was entered correctly in the control panel (see section 4.6.2) and to coordinate with the operator.

07:DIAGNOSTICS **OK** ▶▶ ... ▶▶ SIM NUMBER TEST **OK** ...

Enter the "SIM NUMBER TEST" menu, select the IP server (out of two) used for the verification of the SIM and press **OK**. The panel sends a test SMS to the server.

If the server receives the SMS, the control panel will display "**SIM# verified**" and the test ends successfully. If the SMS was not received, for example, if there is no connection between the control panel and server, the control panel will display "**SIM not verified**".

4.8.5 Testing the Broadband/PowerLink Module ¹

The Broadband diagnostic procedure enables to test the communication of the Broadband Module (see section 4.6.7) with the PowerManage server and reports the diagnostic result. In case of communication failure, detailed information of the failure is reported.

07:DIAGNOSTICS   ...  BROADBAND MODULE  ... PLEASE WAIT... Unit is OK

Notes:

1. When the  button is pressed, the test result may take up to 4 min. before it is displayed.
2. If the Broadband Module is not registered to the PowerMaster 360, the menu "BROADBAND MODULE" will not be displayed.

The following table presents the list of messages that may be reported:

Message	Description
Unit is ok	Broadband Module is functioning correctly.
Test aborted	The diagnostic test is aborted, as follows: <ul style="list-style-type: none"> • AC failure – Broadband Module is set to OFF mode. • Broadband Module has not completed the power-up procedure. In this case, the installer should wait a maximum of 30 seconds before re-testing.
Comm. loss	The RS-232 serial interface between the Broadband Module and the PowerMaster 360 failed.
Rcvr Ip missing	Receivers IP 1 and 2 settings are missing in the PowerMaster 360.
Cable unplugged	The Ethernet cable is not connected to the Broadband Module.
Check lan config	This message appears in any of the following cases: <ul style="list-style-type: none"> • Incorrect Broadband Module IP has been entered. • Incorrect subnet mask has been entered. • Incorrect default gateway has been entered. • DHCP server failure.
Rcvr#1 UnReach. Rcvr#2 UnReach.	Receiver 1 or 2 is inaccessible, as follows: <ul style="list-style-type: none"> • Wrong receiver IP has been entered. • Receiver failure. • WAN Network failure.
Rcvr#1 UnReg. Rcvr#2 UnReg.	The PowerMaster 360 unit is not registered to IP receiver 1 or 2.
Timeout err.	Broadband Module does not respond to test result within 70 sec.
Invalid result	Broadband Module responds with a result code that is not recognized by the PowerMaster 360.

4.9 User Settings

This USER SETTINGS menu provides you with a gateway to the user settings through the regular user menus. Refer to the PowerMaster 360 User's Guide for detailed procedures.

¹ The name of the product is PowerLink3 IP Communicator

4. PROGRAMMING

4.10 Factory Default

The FACTORY DEFLT menu enables you to reset the PowerMaster 360 parameters to the factory default parameters. To obtain the relevant parameters defaults, contact the PowerMaster 360 dealer. Reset factory default parameters as follows:

Step 1	Step 2	Step 3	Step 4	Step 5
Select "09:FACTORY DEFLT" menu	Select "<OK> to restore"	Enter Installer Code	Resetting of factory default parameters is underway	

Notes:

- 1) For PowerMaster 360 with 2 installer codes, INSTALLER code and MASTER INSTALLER code, only the master installer code enables to perform the factory default function.
- 2) If the Soak Test is active, performing factory default will restart the Soak Test.

4.11 Serial Number

The SERIAL NUMBER menu enables reading the system serial number and similar data for support purposes only. To read the system serial number and other relevant data proceed as follows:

Step 1	Step 2	Step 3																
Select "10:SERIAL NUMBER" menu	Click next repeatedly to view relevant data.																	
<table border="1"> <thead> <tr> <th></th> <th>Definition</th> </tr> </thead> <tbody> <tr> <td>0907030000.</td> <td>Control panel serial number</td> </tr> <tr> <td>JS702766 L18.154</td> <td>Control panel software version</td> </tr> <tr> <td>PANEL ID: 100005</td> <td>Control panel ID for PowerManage connectivity</td> </tr> <tr> <td>J-702770 L18.154</td> <td>Control panel default version</td> </tr> <tr> <td>JS702767 L01.023</td> <td>Control panel boot version</td> </tr> <tr> <td>JS702768 L02.003</td> <td>Control panel Remote Software Upgrade downloader version</td> </tr> <tr> <td>PL8.0.10 1111</td> <td>Displays the PowerLink software version</td> </tr> </tbody> </table>				Definition	0907030000.	Control panel serial number	JS702766 L18.154	Control panel software version	PANEL ID: 100005	Control panel ID for PowerManage connectivity	J-702770 L18.154	Control panel default version	JS702767 L01.023	Control panel boot version	JS702768 L02.003	Control panel Remote Software Upgrade downloader version	PL8.0.10 1111	Displays the PowerLink software version
	Definition																	
0907030000.	Control panel serial number																	
JS702766 L18.154	Control panel software version																	
PANEL ID: 100005	Control panel ID for PowerManage connectivity																	
J-702770 L18.154	Control panel default version																	
JS702767 L01.023	Control panel boot version																	
JS702768 L02.003	Control panel Remote Software Upgrade downloader version																	
PL8.0.10 1111	Displays the PowerLink software version																	

4.12 Partitioning

4.12.1 General Guidance – "Partitioning" Menu

This menu allows you to enable/disable partitions in the system (for further details, see APPENDIX E).

4.12.2 Enabling / Disabling Partitions

To enable or disable the partition feature, proceed as follows:

Step 1	Step 2	Step 3	Step 4
Select "12:PARTITIONING" menu	Select whether to "Enable" or "Disable" Partitions	Partitions are now enabled	

4.13 Operation Mode





Note: The Operation Mode feature is applicable only in specific PowerMaster 360 variants.

4.13.1 General Guidance – "Operation Mode" Menu

This mode allows you to select an operation mode for the control panel according to specific compliance standards. Each operation mode has its own configuration.

4.13.2 Select setting

To select the desired operation mode, proceed as follows:

Step 1	Step 2	Step 3	Step 4
Select "13:OPERATION MOD" menu	Enter "01:SELECT MODE"	Select "NORMAL", "EN-50131", "DD243", "BS8243", "INCERT" or "CP01"	
 13:OPERATION MOD	 01 SELECT MODE	 NORMAL ■	 → to Step 2

Note: If "Normal / EN-50131 / INCERT" is selected, the control panel will operate according to OTHERS setup configuration (see section 4.13.6).

4.13.3 BS8243 Setup

13:OPERATION MOD   ...  02:BS8243 SETUP 
--

Enter the "02:BS8243 SETUP" menu to configure its settings.

Option	Configuration Instructions
01:DISARM OPTION	<p>Define when it is possible to disarm the system:</p> <p>entry/BS devs (default) – By keypad after the entry delay has expired and if an alarm occurred in the system. By keyfob or KP-160 PG2 at all times.</p> <p>entry/all devs - During entry delay, when the system is armed AWAY, by all devices. When not in entry delay by keyfob or KP-160 PG2 only.</p> <p>entry/DD devs - During entry delay, when the system is armed AWAY, by using the keyfob or KP-160 PG2. Keypads cannot disarm at all.</p> <p>anytime/all dev – At any time and by all devices.</p>
02:ENTRY ALARM	<p>Define whether the system will report a confirmed alarm during an entry delay (see CONFIRM ALARM below).</p> <p>BS8243 (default) – An alarm initiated by another detector during the entry delay is regarded as a confirmed alarm. An additional 30 seconds delay is added to the entry delay for reporting the event (does not affect the Abort Time, see section 4.5.4).</p> <p>BS8243 no cnfrm - The panel will not send any confirmed alarm once a delay zone has been activated, until the control panel is disarmed.</p> <p>DD243 - An alarm initiated by another detector during the entry delay is not regarded as a confirmed alarm.</p> <p>normal mode - The control panel will report a confirmed alarm for the second alarm that is triggered from a different zone within the confirmation time. There are no alarm restrictions during entry delay or for the delay zone.</p>
03:END EXIT MODE	<p>Define how the exit delay is terminated or restarted according to the following options:</p> <p>door/fob only (default) - When the door is closed, or by pressing the AUX button on the keyfob¹, whichever first.</p> <p>restart>reentry - Exit delay restarts when the door is reopened during exit delay. The restart occurs once only. Restarting the exit delay is helpful if the user re-enters immediately after going out to retrieve an item that was left behind.</p> <p>door/fob/timer - When the door is closed, by pressing the AUX button on the keyfob¹, or when the exit delay has expired, whichever first.</p> <p>fob/timer - By pressing the AUX button on the keyfob¹, or when the exit delay has expired, whichever first.</p>

¹ Applies only when the keyfob is defined as "skip exit delay" (for further details, see the keyfob's User's Guide)

4. PROGRAMMING

Option	Configuration Instructions
04:FOB/KP PANIC	Define the devices that cannot trigger a panic alarm. BS8243 (default) – KF-234 PG2 and KF-235 PG2. all - All devices can trigger a panic alarm
05:CONFIRM ALARM	Define a specific time period that if 2 successive alarms occur, the second alarm will be considered as a confirmed alarm , (see RPT CNFM ALRM below). Options: in 30 (default)/ 45/60/90 minutes
06:CONFIRM PANIC	A confirmed panic alarm is reported if one of the following occurs within the confirmation time: a) A second panic device is activated. b) A second panic alarm on the same device is activated. c) A tamper event is activated (not from the zone / device that initiated the panic alarm). Options: in 4/8/12/20 (default)/ 24 hours and disabled
07:RPT CNFM ALRM	Define whether the system will report a confirmed alarm. enable + bypass (default) - The system will report a confirmed alarm and will bypass all alarmed open zones when the siren ends or when the confirmation timer expires. disable - The system will not report a confirmed alarm. enable - The system will report a confirmed alarm.
08:ENTRY DELAY 1 09:ENTRY DELAY 2	Two different entry delays allow the user to enter the protected site (while the system is in the armed state) via 2 specific doors and routes without causing an alarm. Following entry, the user must disarm the control panel before the entry delay expires. Slow-rate warning beeps start sounding once the door is opened, until the last 10 seconds of the delay, during which the beeping rate increases. Locations No. 1 (entry delay 1) and 2 (entry delay 2) allow you to program the length of these delays. Options: 10/15/30 (ENTRY DELAY 1 <i>default</i>)/ 45/60 (ENTRY DELAY 2 <i>default</i>) seconds; 3/4 minutes
10:ABORT TIME	The PowerMaster 360 can be configured to provide a delay before reporting an alarm to the Monitoring Station (not applicable to alarms from FIRE, 24H SILENT and EMERGENCY zones). During this delay period, the siren sounds but the alarm is not reported. If the user disarms the system within the delay time, the alarm is aborted. You can activate the feature and select the "Abort Time" interval. Options: in 00 (default in USA)/ 15/30 (default)/ 45/60 seconds; in 2/3/4 minutes
11:CANCEL ALARM	The PowerMaster 360 can be configured to provide a "Cancel Alarm" time window that starts upon reporting an alarm to the Monitoring Station. If the user disarms the system within that "cancel alarm" time, a "cancel alarm" message is sent to the Monitoring Station indicating that the alarm was canceled by the user. Options: not active (default in USA); in 1/5 (default)/ 15/60 minute(s) and in 4 hours .

4.13.4 DD243 Setup



Enter the "03:DD243 SETUP" menu to configure its settings.

Option	Configuration Instructions
01:DISARM OPTION	Define when it is possible to disarm the system: entry/wl+awy kp – By the control panel when the system is armed AWAY. By keyfob or KP-160 PG2 during entry delay only. entry/all devs - During entry delay, when the system is armed AWAY, by all devices. When not in entry delay by keyfob or KP-160 PG2 only. entry/DD devs (default) - During entry delay, when the system is armed AWAY, by using the keyfob or KP-160 PG2. Keypads cannot disarm at all. anytime/all dev – At any time and by all devices.

Option	Configuration Instructions
02:ENTRY ALARM	<p>Define whether the system will report a confirmed alarm during an entry delay (see CONFIRM ALARM below).</p> <p>DD243 (default) - An alarm initiated by another detector during the entry delay is not regarded as a confirmed alarm.</p> <p>normal mode - The control panel will report a confirmed alarm for the second alarm that is triggered from a different zone within the confirmation time. There are no alarm restrictions during entry delay or for the delay zone.</p>
03:END EXIT MODE	<p>Define how the exit delay is terminated or restarted according to the following options:</p> <p>door/fob only - When the door is closed, or by pressing the AUX button on the keyfob¹, whichever first.</p> <p>restart>reentry - Exit delay restarts when the door is reopened during exit delay. The restart occurs once only. Restarting the exit delay is helpful if the user re-enters immediately after going out to retrieve an item that was left behind.</p> <p>door/fob/timer - When the door is closed, by pressing the AUX button on the keyfob¹, or when the exit delay has expired, whichever first.</p> <p>fob/timer (default) - By pressing the AUX button on the keyfob¹, or when the exit delay has expired, whichever first.</p>
04:FOB/KP PANIC	<p>Define the devices that cannot trigger a panic alarm.</p> <p>DD243 (default) – KF-234 and KF-235 PG2.</p> <p>all - All devices can trigger a panic alarm</p>
05:CONFIRM ALARM	<p>Define a specific time period that if 2 successive alarms occur, the second alarm will be considered as a confirmed alarm, (see RPT CNFM ALRM below).</p> <p>Options: in 30/45/60(default)/90 minutes</p>
06:CONFIRM PANIC	<p>A confirmed panic alarm is reported if one of the following occurs within the confirmation time:</p> <ol style="list-style-type: none"> A second panic device is activated. A second panic alarm on the same device is activated. A tamper event is activated (not from the zone / device that initiated the panic alarm). <p>Options: in 4/8/12/20(default)/24 hours and disabled</p>
07:RPT CNFM ALRM	<p>Define whether the system will report a confirmed alarm.</p> <p>enable + bypass (default) - The system will report a confirmed alarm and will bypass all alarmed open zones when the siren ends or when the confirmation timer expires.</p> <p>disable - The system will not report a confirmed alarm.</p> <p>enable - The system will report a confirmed alarm.</p>
08:ENTRY DELAY 1 09:ENTRY DELAY 2	<p>Two different entry delays allow the user to enter the protected site (while the system is in the armed state) via 2 specific doors and routes without causing an alarm.</p> <p>Following entry, the user must disarm the control panel before the entry delay expires. Slow-rate warning beeps start sounding once the door is opened, until the last 10 seconds of the delay, during which the beeping rate increases. Locations No. 1 (entry delay 1) and 2 (entry delay 2) allow you to program the length of these delays.</p> <p>Options: 10/15/30(ENTRY DELAY 1 default)/45/60(ENTRY DELAY 2 default) seconds; 3/4 minutes</p>
10:ABORT TIME	<p>The PowerMaster 360 can be configured to provide a delay before reporting an alarm to the monitoring station (not applicable to alarms from FIRE, 24H SILENT and EMERGENCY zones). During this delay period, the siren sounds but the alarm is not reported. If the user disarms the system within the delay time, the alarm is aborted. You can activate the feature and select the "Abort Time" interval.</p> <p>Options: in 00 (default in USA)/15/30 (default)/45/60 seconds; in 2/3/4 minutes</p>

¹ Applies only when the keyfob is defined as "skip exit delay" (for further details, see the keyfob's User's Guide)

4. PROGRAMMING

Option	Configuration Instructions
11:CANCEL ALARM	The PowerMaster 360 can be configured to provide a "Cancel Alarm" time window that starts upon reporting an alarm to the Monitoring Station. If the user disarms the system within that "cancel alarm" time, a "cancel alarm" message is sent to the Monitoring Station indicating that the alarm was canceled by the user. Options: not active (default in USA); in 1/5 (default)/ 15/60 minute(s) and in 4 hours .

4.13.5 CP01 Setup

13:OPERATION MOD   ...  CP01 SETUP 

Enter the "04:CP01 SETUP" menu to configure its settings.

Option	Configuration Instructions
01:DISARM OPTION	Certain regulations require that when the system is armed in AWAY mode, it may not be disarmed from the outside of the house (such as by keyfobs) before entering the protected premises and activating an "Entry Delay" zone. To answer this requirement, the PowerMaster 360 provides you with the following configurable options to disarm the system: any time (default) – the system can be disarmed at all times from all devices. on entry wrless – During entry delay, the system can be disarmed only using keyfob or prox operated devices. entry + away kp. – During entry delay by code, the system can be disarmed only using PowerMaster 360 Virtual Keypad . on entry all. – During entry delay, the system can be disarmed using keyfobs or by code using the PowerMaster 360 Virtual Keypad.
03:END EXIT MODE	Define how the exit delay is terminated or restarted according to the following options: restart+arm home (default) – During exit delay if the door was not opened, the alarm system will be armed HOME instead of armed AWAY. restart>reentry - Exit delay restarts when the door is reopened during exit delay. The restart occurs once only. Restarting the exit delay is helpful if the user re-enters immediately after going out to retrieve an item that was left behind. door/fob/timer - When the door is closed, by pressing the AUX button on the keyfob ¹ , or when the exit delay has expired, whichever first. fob/timer - By pressing the AUX button on the keyfob ¹ , or when the exit delay has expired, whichever first.
05:CONFIRM ALARM	Define a specific time period that if 2 successive alarms occur, the second alarm will be considered as a confirmed alarm, (see RPT CNFM ALRM below). Options: disable (default in USA); in 30/45/60 (default)/ 90 minutes
07:RPT CNFM ALRM	Define whether the system will report a confirmed alarm. report disabled (default) - The system will not report a confirmed alarm. report enabled - The system will report a confirmed alarm.
08:ENTRY DELAY 1 09:ENTRY DELAY 2	Two different entry delays allow the user to enter the protected site (while the system is in the armed state) via 2 specific doors and routes without causing an alarm. Following entry, the user must disarm the control panel before the entry delay expires. Slow-rate warning beeps start sounding once the door is opened, until the last 10 seconds of the delay, during which the beeping rate increases. Locations No. 1 (entry delay 1) and 2 (entry delay 2) allow you to program the length of these delays. Options: 30 (default)/ 45/60 seconds ; 3/4 minutes
10:ABORT TIME	The PowerMaster 360 can be configured to provide a delay before reporting an alarm to the monitoring station (not applicable to alarms from FIRE, 24H SILENT, EMERGENCY, GAS FLOOD and TEMPERATURE zones). During this delay period, the external siren will not sound and the alarm is not reported. If the user disarms the system within the delay time, the alarm is aborted. Options: in 15 (default)/ 30/45 seconds

¹ Applies only when the keyfob is defined as "skip exit delay" (for further details, see the keyfob's User's Guide)

Option	Configuration Instructions
11:CANCEL ALARM	Define the "cancel alarm" period that starts upon reporting an alarm to the Monitoring Station. If the user disarms the system within that time period, a "cancel alarm" message is sent to the Monitoring Station. Options: in 5 (default)/ 15/60 minutes ; in 4 hours
12:CNCEL ANOUNCE	Define whether a special beep will sound when an alarm cancel event is sent to the monitoring station. enable (default) and disable
13:ABORT ANOUNCE	Define that when the user disarms the system within the allowed abort interval a special beep will sound to indicate "no alarm transmission". enable (default) and disable

4.13.6 OTHERS Setup

13:OPERATION MOD   ...  05:OTHERS SETUP 

Enter the "05:OTHERS SETUP" menu to configure its settings.

Option	Configuration Instructions
01:DISARM OPTION	Certain regulations require that when the system is armed in AWAY mode, it may not be disarmed from the outside of the house (such as by keyfobs) before entering the protected premises and activating an "Entry Delay" zone. To answer this requirement, the PowerMaster 360 provides you with the following configurable options to disarm the system: any time (default) – the system can be disarmed at all times from all devices. on entry wrless – During entry delay, the system can be disarmed only using keyfob or prox operated devices. entry + away kp. – During entry delay by code, the system can be disarmed only using PowerMaster 360 Virtual Keypad. on entry all. – During entry delay, the system can be disarmed using keyfobs or by code using the PowerMaster 360 Virtual Keypad.
03:END EXIT MODE	The "Exit Delay" time can be further adjusted according to your preferred exit route. The control panel provides you with the following " Exit Mode " options: A: "normal" (default) - The exit delay is exactly as defined. B: "restart>reentry" - The exit delay restarts when the door is reopened during exit delay. The restart occurs once only. Restarting the exit delay is helpful if the user re-enters immediately after going out to retrieve an item that he left behind. C: "end by exit" - The exit delay expires (ends) automatically when the exit door is closed even if the defined exit delay time was not completed. Options: normal (default); restart>reentry and end by exit .
05:CONFIRM ALARM	Define a specific time period that if 2 successive alarms occur, the second alarm will be considered as a confirmed alarm, (see RPT CNFM ALRM below). Options: disable (default in USA); in 30/45/60 (default)/ 90 minutes
07:RPT CNFM ALRM	Define whether the system will report a confirmed alarm. report disabled (default) - The system will not report a confirmed alarm. report enabled - The system will report a confirmed alarm.
08:ENTRY DELAY 1 09:ENTRY DELAY 2	Two different entry delays allow the user to enter the protected site (while the system is in the armed state) via 2 specific doors and routes without causing an alarm. Following entry, the user must disarm the control panel before the entry delay expires. Slow-rate warning beeps start sounding once the door is opened, until the last 10 seconds of the delay, during which the beeping rate increases. Locations No. 1 (entry delay 1) and 2 (entry delay 2) allow you to program the length of these delays. Options : 00/15 (ENTRY DELAY 2 default)/ 30 (ENTRY DELAY 1 default)/ 45/60 seconds ; 3/4 minutes

4. PROGRAMMING





Option	Configuration Instructions
10:ABORT TIME	<p>The PowerMaster 360 can be configured to provide a delay before reporting an alarm to the monitoring station (not applicable to alarms from FIRE, 24H SILENT and EMERGENCY zones). During this delay period, the siren sounds but the alarm is not reported. If the user disarms the system within the delay time, the alarm is aborted. You can activate the feature and select the "Abort Time" interval.</p> <p>Options: in 00 (default in USA)/15/30(default)/45/60 seconds; in 2/3/4 minutes</p>
11:CANCEL ALARM	<p>The PowerMaster 360 can be configured to provide a "Cancel Alarm" time window that starts upon reporting an alarm to the Monitoring Station. If the user disarms the system within that "cancel alarm" time, a "cancel alarm" message is sent to the Monitoring Station indicating that the alarm was canceled by the user.</p> <p>Options: not active (default in USA); in 1/5 (default)/15/60 minute(s) and in 4 hours.</p>

5. PERIODIC TEST

5.1 General Guidance



This mode provides you with the means to conduct a periodic test of all system sirens, detectors, keyfobs, keypads, repeaters and other peripheral devices, via the "PERIODIC TEST" menu, at least once a week and after an alarm event. When you are instructed to perform a periodic test, walk throughout the site to check the detectors / sensors (except for Temperature Sensors). When a detector/sensor is triggered into alarm, its name, number and the alarm reception level should be indicated (for example, "Bathroom", "Z19 strong") and the buzzer should sound according to the alarm reception level (1 of 3). Each device should be tested according to the device Installation Instructions.

To enter the "PERIODIC TEST" menu and to conduct a periodic test, proceed as follows:

Step 1	①	Step 2	①
READY	[1]	Select the test to be performed	[2]
 			
PERIODIC TEST (enter installer / master code)		SIRENS TEST TEMPERATURE TEST TEST ALL DEVICES TEST ONE DEVICE	

① ① – Periodic Test

[1] Not including Siren and Temperature Sensors

[2] After reviewing all untested devices the control panel will read "<OK> TO END". You can now do one of the following: press  to abort the testing procedure; press  to continue the testing procedure; or press  to exit the testing procedure.

5.2 Conducting a Periodic Test

The PowerMaster 360 enables you to conduct the periodic test in five parts:

Siren Test: Each siren of the system is automatically activated for 3 seconds (outdoor sirens with low volume).

Temperature Sensor Test: When Temperature Sensors are enrolled in the system, the Virtual Keypad displays the temperature of each zone in Celsius or Fahrenheit.







Test all devices: All devices are tested.

Other Device Test: Each of the other devices in the system is activated by the installer and the display indicates which devices were not yet tested. The "it's me" indication helps to identify the untested devices if necessary. A counter also indicates the number of devices that remain untested.

Email Test: Generates an event to be sent to the predefined private email addresses.

READY   ...  PERIODIC TEST   ...  MENU you wish 

To conduct a periodic test, make sure the system is disarmed and then enter the "PERIODIC TEST" menu using your installer code (8888 by default) or master installer code (9999 by default). Immediately after entering the "PERIODIC TEST" menu, all the LEDs on the panel will momentarily light (LED test).

Option	Instructions
SIRENS TEST	<p>You can test wireless sirens and strobes and sirens of smoke sensors.</p> <p>To initiate the siren test, press  . The display now reads "SIREN N". "N" indicates the zone location assigned to the siren that is currently being tested.</p> <p>The first siren enrolled in the panel sounds for 3 seconds after which the PowerMaster 360 system will automatically repeat the procedure for the next siren enrolled in the system until all sirens are tested. You should listen to the sirens sounds and make sure that all sirens sound.</p> <p>Once all the sirens have been tested, the control panel will now test the sirens of smoke sensors that are enrolled in the alarm system. The display now reads "Zxx: SMOKE SIREN", where "Zxx" indicates the zone number of the smoke sensor, and alternates with "<OK> TO CONTINUE". During this time, the siren of the tested smoke sensor will sound for up to one minute.</p> <p>Press   to test the siren of the next smoke sensor.</p> <p>When the sirens test is complete, the display reads "SIREN TESTS END". Press the   or the  button to confirm the test.</p>

5. PERIODIC TEST

Option	Instructions
TEMPERATURE TEST	<p>The control panel reads the temperature of the zone.</p> <p>To display the temperature of zones on the control panel, press OK. The control panel reads the temperature of each zone. The display alternates between the temperature, the sensor number and the sensor location, as in the following example: "Z01 24.5°C" changes to "Z01:Temp. Sensor" changes to "Guest room". Repeatedly click the ▶▶ button to review the temperature of each zone (by Temperature Sensor).</p> <p>When the temperature of all zones has been reviewed, the display reads "DEVICE TESTS END". Press the OK or the ▶▶ button to confirm the test and then move to the next step to test the other devices.</p>
TEST ALL DEVICES	<p>You can test all devices in one procedure.</p> <p>While in "TEST ALL DEVICES", press OK to initiate the test.</p> <p>The control panel now reads "NOT TESTED NNN". "N" indicates the number of enrolled devices in the control panel that have not been tested. This number automatically drops one count for every tested device.</p> <p>When the "NOT TESTED NNN" screen appears, walk throughout the site to test the detectors / sensors or press any key of the selected handheld device to initiate the test. After a device has been activated, the control panel reads "Zxx IS ACTIVATED" and the "N" indicator drops one count.</p> <p>Pressing OK during the testing process will display details of each device that has not yet been tested. The control panel reads the device number, followed by the device type (for example, Contact Sensor, Motion Sensor or Keyfob) and followed by the device location. At this stage, pressing any one of the following keys will open the following options:</p> <ol style="list-style-type: none">1. Press ▶▶ to view details of the next untested device.2. Press 🔒 to exit the test process. <p>During testing, you can also check the signal strength indication of each device according to the number of LED blinks of the device, (for further details, refer to the device Installation Instructions).</p> <p>After all devices have been tested, the control panel reads "DEVICE TESTS END".</p>
TEST ONE DEVICE →CONTACT SENSORS →MOTION SENSORS →GLASSBREAK SENS. →SHOCK SENSORS	<p>Select a specific device group you wish to test. For example, Motion Sensors.</p> <p>Press OK to enter the "TEST ONE DEVICE" sub menu and use ▶▶ to scroll through the device families. Press OK to enter the < device family > sub menu. For example: "MOTION SENSORS".</p> <p>The following screens will appear: "Xxx:<device name>" ↶ <location> Where "Xxx" indicates the device number.</p> <p>If there is no device, the following screen will appear: "NO EXISTING DEV.".</p> <p>Press OK to test the selected device. The following screen will appear: "Z01 ACTIVATE NOW".</p> <p>Walk throughout the site to test the detectors / sensors or press any key of the selected handheld device to initiate the test.</p> <p>During testing, you can also check the signal strength indication of each device, (for further details, refer to the device Installation Instructions).</p> <p>At the end of the test process the panel will revert to: "TEST ONE DEVICE".</p> <p>To test the microwave range of the dual detector:</p> <ol style="list-style-type: none">1. Press OK to enter the "TEST ONE DEVICE" sub menu and use ▶▶ to navigate to "MOTION SENSORS".2. Press OK; the following screens will appear: "Z01:Motion Sens" ↶ <location>.3. Press ▶▶ continuously to select a different zone number.4. Press OK; If the selected device is Tower-32AM PG2, the following screens will appear: "<OK MW ADJUST>" ↶ "<NEXT> TEST ONE".

Option	Instructions
	<p>To test the microwave range, go to step 5. To test a different microwave range, go to step 7.</p> <ol style="list-style-type: none"> Press ▶▶; the following screen will appear: "ACTIVATE MW NOW". Activate the device; the screen will return to "TEST ONE DEVICE". <p>You can now repeat the procedure for another dual detector.</p> <ol style="list-style-type: none"> Press OK to select the sensitivity setting. Press ▶▶ continuously to select between "Minimum" (default), "Medium" or "Maximum". Press OK; the panel will receive an acknowledge from the device that is indicated by a black box next to the selected setting. Thereafter, the screen momentarily changes to "ACTIVATE MW NOW" and then returns to the selected setting. If you press ↩, the adjustment procedure ends. <p>Important: The procedure mentioned above is for testing purposes only and does not change the detector settings. The settings must be saved through the MODIFY DEVICES menu.</p> <p>To test the shock detector:</p> <ol style="list-style-type: none"> Press OK to enter the "TEST ONE DEVICE" sub menu and use ▶▶ to navigate to "SHOCK SENSORS". Press OK; the following screens will appear: "Zxx:Shk+AX+CntG3"¹ ↻ <location>. Press ▶▶ continuously to select a different zone number. Press OK; the following screens will appear: "Zxx ACTIVATE NOW" ↻ "SHOCK NOT ACTIV." ↻ "CNTACT NOT ACTIV" ↻ "AUXIL. NOT ACTIV". <p>Note: The above screens are the full range of screens that can appear and indicate the inputs that have not yet been activated. However, since there are various models of the shock detector, not all of these screens will appear on some models.</p> <ol style="list-style-type: none"> At this stage, activate each input of the shock detector in turn. <p>To test motion detector with integrated camera (Next CAM PG2 or TOWER CAM PG2):</p> <ol style="list-style-type: none"> Press OK to enter the "TEST ONE DEVICE" sub menu and use ▶▶ to navigate to "MOTION SENSORS". Press OK; the following screens will appear: "Z01:Motion Sens" ↻ <location>. Press ▶▶ continuously to select a different zone number. Press OK; the following screen will appear: "Zxx ACTIVATE NOW". Activate the input of the detector; the following screens will appear: "<Zxx IS ACTIVATE>" ↻ "<OK> SEND IMAGE".

E-MAIL TEST

To test emails, proceed as follows:

While in "**E-MAIL TEST**", press **OK** to initiate the test.

The following screen will appear: "**Please wait...**" and at the termination of the test will change to <Pls chck MailBox>.

Check the private email inbox to view the sent email.

Note:

- For test success, the event must first reach the server before the server can send the email to the user's inbox.
- Since a Burglary alarm is sent, an alarm event must be configured for reporting events (see sections 4.6.3 "Configuring Events Reporting to Monitoring Stations" and 4.6.4 "Configuring Events Reporting to Private Users").

¹ Depending on shock detector model, one of the following may appear instead: "**Zxx:Shk+AX**" / "**Zxx:Shk+CntG3**" / "**Zxx:Shk+CntG2**".

6. MAINTENANCE

6.1 Handling System Troubles

Fault	What it means	Possible Solution
1-WAY	The control panel cannot configure or control the device. Battery consumption increases.	<ul style="list-style-type: none"> • Make sure the device is physically present. • Check the display for device faults, for example, low battery. • Use RF diagnostics to check the current signal strength and during the last 24 hours. • Open the device cover and replace the battery or press the tamper switch. • Install the device in a different location. • Replace the device.
AC FAILURE	There is no power to gas sensor	Make sure that the AC power supply is connected properly
AC SUPPLY FAILURE	There is no power and the system is working on backup battery power	Make sure that the AC power supply is connected properly
CLEAN ME	The fire detector must be cleaned	Use a vacuum cleaner to clean the detector air vents occasionally to keep them free of dust.
COMM. FAILURE	A message could not be sent to the monitoring station or to a private telephone (or a message was sent but was not acknowledged)	<ul style="list-style-type: none"> • Check telephone cable connection • Check that correct telephone number has been dialed. • Dial Monitoring Station to check whether or not events are received.
CPU LOW BATTERY	The backup battery within the control panel is weak and must be replaced (see section 6.2, Replacing the Backup Battery).	<ul style="list-style-type: none"> • Check for AC power is available in the Panel. • If trouble exists for more than 72 hours, replace the battery pack
CPU TAMPER OPEN	The control panel was physically tampered with or its cover was opened, or it was removed from wall.	The control panel is not closed properly. Open the control panel and then close it.
GAS TROUBLE	Gas detector failure	Gas detector: Disconnect and then put back the AC power supply connector CO Gas detector: Replace the detector
GSM NET FAIL	The GSM communicator is not able to connect to the cellular network.	<ul style="list-style-type: none"> • Move the Panel and GSM unit to another location. • Enter and exit the Installer Mode menu • Disconnect GSM unit and install it again • Replace SIM card • Replace the GSM unit
JAMMING	A radio-frequency signal which is blocking communication channel of sensors and control panel is detected.	Locate the source of interference by switching off any wireless devices (cordless telephones, wireless ear plugs, etc.) in the house for 2 minutes then check if trouble continues. Use also RF diagnostics to check signal strength.
LINE FAILURE	There is a problem with the telephone line	<ul style="list-style-type: none"> • Lift the telephone receiver and make sure a telephone line can be heard • Check the telephone connection to the control panel
LOW BATTERY	The battery in a sensor, keyfob or wireless	<ul style="list-style-type: none"> • For AC powered devices, check AC power

Fault	What it means	Possible Solution
	commander is near the end of its useful life.	<ul style="list-style-type: none"> is available and connected to the device. Replace the device battery.
MISSING	A device or detector has not reported for some time to the control panel.	<ul style="list-style-type: none"> Make sure the device is physically present. Check the display for device faults, for example, low battery. Use RF diagnostics to check the current signal strength and during the last 24 hours. Replace the battery. Replace the device.
NOT NETWORKED	A device was not installed or not installed correctly, or, cannot establish communication with the control panel after installation.	<ul style="list-style-type: none"> Make sure the device is physically present. Use RF diagnostics to check the current signal strength and during the last 24 hours. Open the device cover and replace the battery or press the tamper switch. Enroll the device again.
RSSI LOW	The GSM communicator has detected that GSM network signal is weak	Move the Panel and GSM unit to another location.
SIREN AC FAILURE	There is no power to the siren	Make sure that the AC power supply is connected properly
TAMPER OPEN	The sensor has an open tamper	Close sensor tamper
TROUBLE	The sensor reports trouble	Replace the sensor
SOAK TEST FAIL	Detector alarms when in Soak Test mode	<p>If you wish to continue the Soak Test, no further action should be taken.</p> <p>If you wish to abort the Soak Test, disable the Soak Test (see section 4.4.6).</p>

6.2 Replacing the Backup Battery

Replacement and first-time insertion of battery pack is similar, see Figure 3.2.

With a fresh battery pack, correct insertion and tightened battery compartment lid, the TROUBLE indicator should extinguish. However, the "MEMORY" message will now blink in the Virtual Keypad display (caused by the "tamper" alarm you triggered when opening the battery compartment lid). Clear it by arming the system and immediately disarming.

6.3 Replacing/Relocating Detectors

Whenever maintenance work involves replacement or re-location of detectors, always perform a **full diagnostic test according to section 4.8**.

Remember! A "poor" signal is not acceptable.

6.4 Annual System Check

Note: *The PowerMaster 360 system must be checked by a qualified technician at least once every three (3) years (preferably every year).*

The annual system check is designed to ensure proper operation of the alarm system by performing the following checks:

- Periodic test
- Arm/disarm function
- No trouble messages are displayed on the Virtual Keypad
- The clock displays the correct time
- Reporting: generating an event to be transmitted to the Monitoring Station and to the user.

7. READING THE EVENT LOG

Up to 100 events are stored in the event log. You can access this log and review the events, one by one. If the event log fills up completely, the oldest event is deleted upon registration of each new event. The date and time of occurrence are memorized for each event.

Note: Up to 250 events are stored in the event log that can be reviewed via the Remote Programmer PC software application or by the remote PowerManage server.

When reading the event log, events are shown in chronological order - from the newest to the oldest. Access to the event log is provided by clicking the button and not through the Installer Mode menu. The reading and erasing process of the event log is shown below.

Step 1	Step 2	Step 3	Step 4
In normal operating mode [1]	Enter Installer Code [2]	Reviewing Events [3]	Scroll List of Events [4]
READY 00:00	ENTER CODE: █ ↓ LIST OF EVENTS	Z13 alarm 09/02/11 3:37 P	SR2 TAMPER-ALARM 07/02/11 11:49 a
Step 5	Step 6	Step 7	Step 8
CLEAR EVENT LOG display [5]	Erase the Event Log [6]	Event Log is erased [7]	Returns to normal operating mode [8]
→		→	
CLEAR EVENT LOG	<OFF> to delete	<OK> TO EXIT	READY 00:00

① - Reading Events

- [1] While the system is in the normal operating mode, press the key.

Reading the Event Log

- [2] Enter the current Installer Code and then press to enter "LIST OF EVENTS".
- [3] The latest event is shown.
The event is displayed in two parts, for example, "Z13 alarm" then "09/02/10 3:37 P".

Note: In Soak Test mode, the panel displays the alarmed zone and alternates with "Zxx:Soak T.Fail".

- [4] Press repeatedly to scroll through the list of events.

Erasing and Exiting the Event Log:

- [5] From anywhere within the event log, press the button and then press .
- [6] At this stage in the procedure, clicking the or buttons will take you to "<OK> TO EXIT" without erasing the event log. Clicking the button will revert to "CLEAR EVENT LOG".
Press the button to erase the event log.
- [7] The system erases the event log
- [8] Press to revert to normal operating mode.

Clicking the button repeatedly at any stage in the procedure takes you one level up with each click.
Clicking the button will take you to "<OK> TO EXIT".

APPENDIX A. PowerMaster 360 Configurator

The PowerMaster 360 Configurator is the interface with the installed PowerMaster 360 security system. Installers and home/property owners configure the Communication settings with the Central Monitoring Station. Installers configure the system through the Configurator's Virtual Keypad.

A1. Working with the PowerMaster Configurator

1. Connect the USB cable to the PowerMaster 360 and to the laptop.

Note: In some cases Windows will require manual installation of the USB driver. To perform this, follow the detailed instructions in section A2.

When the PowerMaster 360 is ready, the LEDs conditions are as follows:

Power	ON	GREEN
Arming Status	AWAY	RED
	HOME	RED BLINK
	DISARM	OFF
Troubles	OFF no troubles; ON active troubles	ORANGE
Connection	ON: connected to PowerManage; OFF: Ethernet cable disconnected; Router turned OFF/disconnected; not connected to PowerManage	BLUE
WiFi ¹	WiFi access point enabled	GREEN
Back LEDs	Initialization, enroll success / failure	RED, GREEN and ORANGE

2. Download the PowerMaster 360 software from the CD.
3. Run the Configurator.exe file. The PowerMaster 360 icon appears on your desktop.

Note: A link to a USB driver is also added to your desktop.

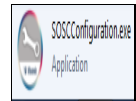

4. Log in with the Password which is the download code that is included with the PowerMaster 360 kit, and then click **Login**.

Note: It is recommended to use the default password that initially appears on the screen.

After several seconds, the Configurator screen appears.

Note: If the Configurator does not allow login, or a USB driver error appears, use the USB driver link on your desktop to install the USB driver. After performing the driver installation, try to login to the Configurator again.

¹ Relevant when WiFi module is mounted

APPENDIX A. PowerMaster 360 Configurator

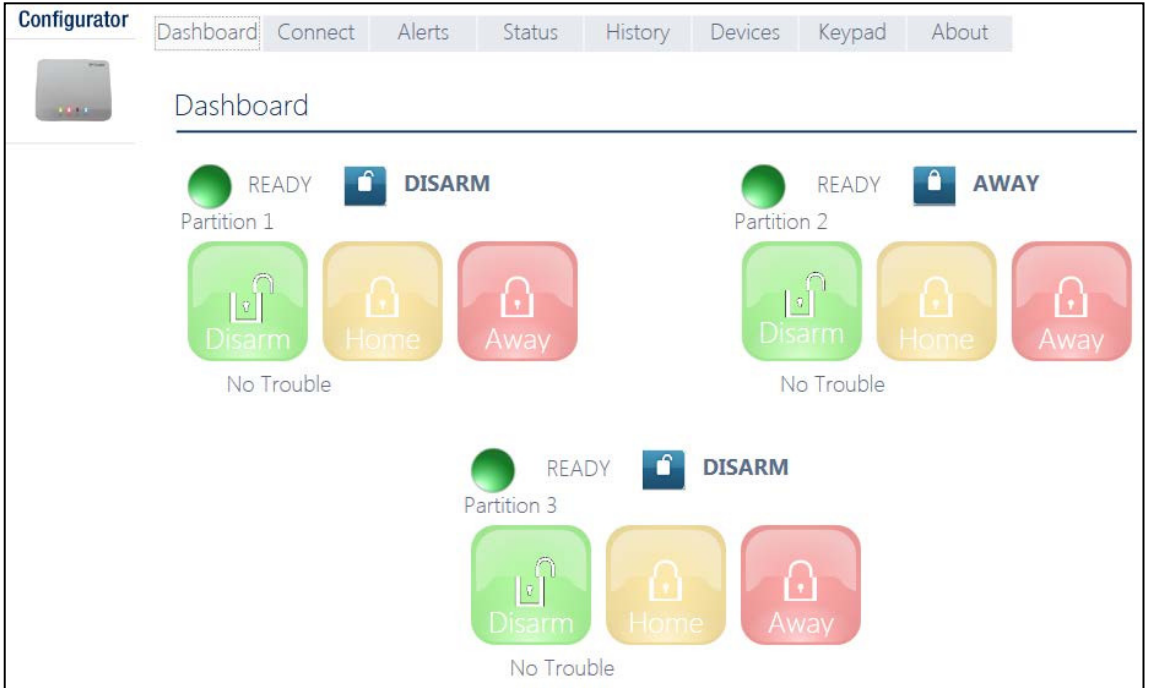

5. The **Dashboard** tab is used to gain quick access for performing basic arming and disarming of the alarm system. In addition, the screen displays system status, assigned partitions and trouble indications.

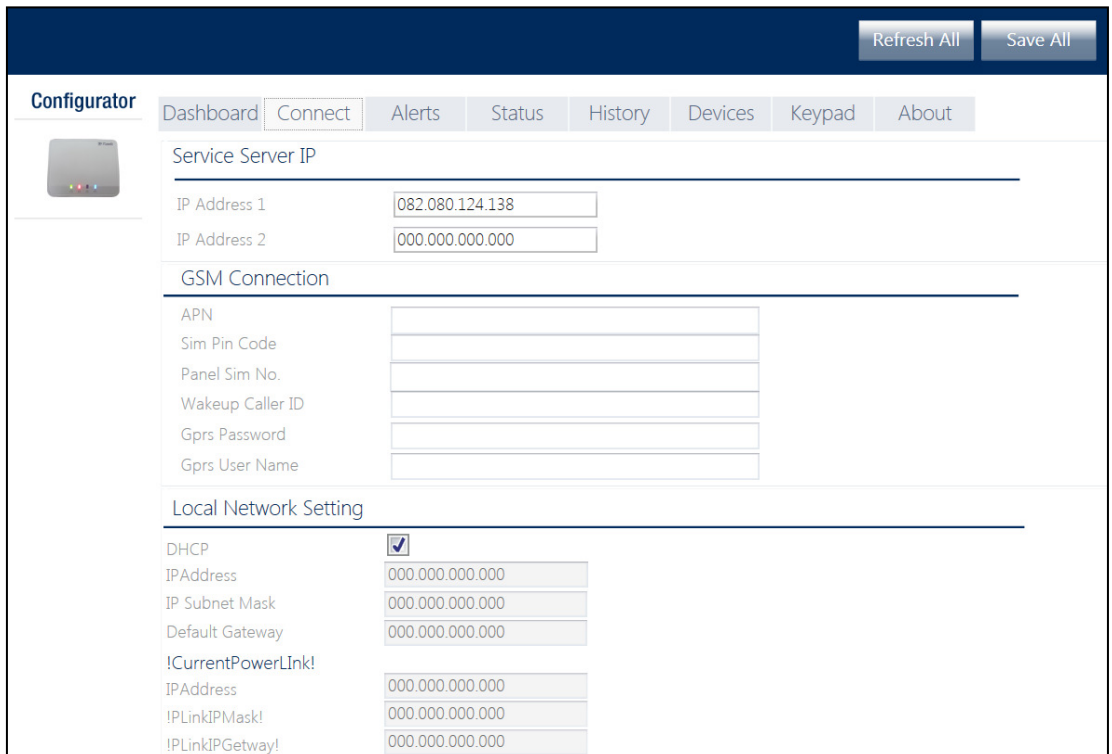

6. Click the **Connect** tab, which includes Broadband network settings. Enter the following settings:
 - **IP Address 1/2:** First and second IP address of the PowerManage server with which the PowerMaster 360 communicates.
 - **APN:** Enter the name of the Access Point used for the internet settings of the GSM.
 - **Sim Pin Code:** Enter the PIN code of the SIM card installed in the GSM module.
 - **Panel Sim No:** Enter the PowerMaster 360 SIM card telephone number.
 - **Wakeup Caller ID:** Enter the "Caller ID" (i.e. telephone number) from which the Monitoring Station calls the control panel for initiating the Up/Download process.
 - **GPRS Password / User Name:** Enter the Password and Username of the APN used for GPRS communications
 - **Local Network Setting DHCP:** Select this option to obtain the PowerMaster 360's IP address automatically. To assign the PowerMaster 360 a specific and permanent IP address, deselect this option and type its IP Address, Subnet Mask and Gateway.
 - **Current PowerLink.** Read only fields that display the current PowerLink IP addresses of the PowerMaster 360.
7. Click **Save All** in the top right corner of the screen.

Note: Save All saves all changes made on all of the Configurator tabs.

The screenshot shows the 'Connect' tab of the PowerMaster 360 Configurator. The interface is divided into several sections:

- Navigation Bar:** Dashboard, Connect, Alerts, Status, History, Devices, Keypad, About.
- Email Alert Setting By Server:** A table with the following data:

Email Address	Alarms	Alerts	Troubles	Open/Close
deonm@visonic.com	<input checked="" type="checkbox"/>	<input checked="" type="checkbox"/>	<input checked="" type="checkbox"/>	<input checked="" type="checkbox"/>
heng@visonic.com	<input checked="" type="checkbox"/>	<input checked="" type="checkbox"/>	<input checked="" type="checkbox"/>	<input checked="" type="checkbox"/>
	<input type="checkbox"/>	<input type="checkbox"/>	<input type="checkbox"/>	<input type="checkbox"/>
	<input type="checkbox"/>	<input type="checkbox"/>	<input type="checkbox"/>	<input type="checkbox"/>
- SMS Alert Setting By Server:** A table with the following data:

SMS #	Alarms	Alerts	Troubles	Open/Close
12345678	<input checked="" type="checkbox"/>	<input checked="" type="checkbox"/>	<input checked="" type="checkbox"/>	<input checked="" type="checkbox"/>
11356789	<input checked="" type="checkbox"/>	<input checked="" type="checkbox"/>	<input checked="" type="checkbox"/>	<input checked="" type="checkbox"/>
	<input type="checkbox"/>	<input type="checkbox"/>	<input type="checkbox"/>	<input type="checkbox"/>
	<input type="checkbox"/>	<input type="checkbox"/>	<input type="checkbox"/>	<input type="checkbox"/>
- SMS Alert Setting By Panel:** A table with the following data:

SMS #	Report SMS
2580	
12345678	Disable Report
11356789	

A green status bar at the bottom left indicates "Connection OK".

8. Click the **Alerts** tab. Here, define up to 4 email addresses and 4 mobile devices to receive forwarded events by e-mail and SMS from the PowerManage server. Additionally, select the types of event messages which each user is allowed to receive (**Alarms, Alerts, Troubles, Open/Close** events).

Notes for installers:

- Verify that the PowerManage server is configured to send emails and SMSs.
- Verify that the Panel event reporting to CMS is defined as ALL.
- Any of these notifications can be sent to the property owner in addition to the Central Monitoring Station. For detailed instructions, see the *PowerMaster 360 Installer and Quick Guide*.

APPENDIX A. PowerMaster 360 Configurator

9. Click **Save All**.

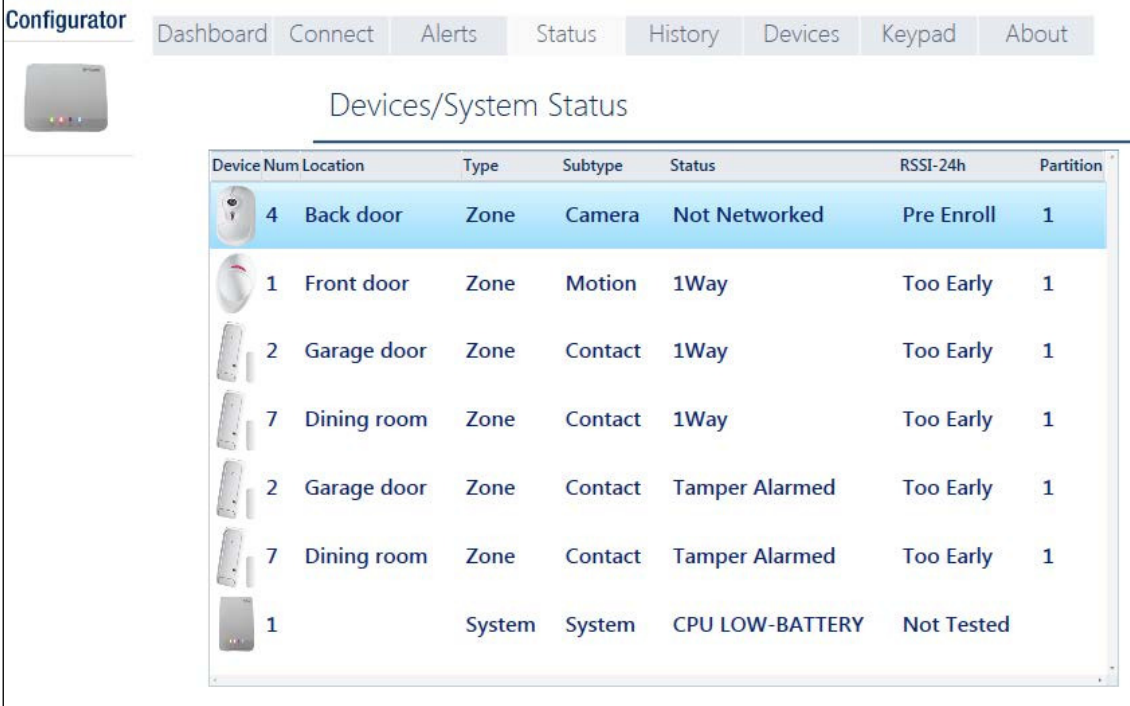

The screenshot shows the 'Configurator' application with the 'Status' tab selected. The main heading is 'Devices/System Status'. Below this is a table with the following data:

Device Num	Location	Type	Subtype	Status	RSSI-24h	Partition
4	Back door	Zone	Camera	Not Networked	Pre Enroll	1
1	Front door	Zone	Motion	1Way	Too Early	1
2	Garage door	Zone	Contact	1Way	Too Early	1
7	Dining room	Zone	Contact	1Way	Too Early	1
2	Garage door	Zone	Contact	Tamper Alarmed	Too Early	1
7	Dining room	Zone	Contact	Tamper Alarmed	Too Early	1
1		System	System	CPU LOW-BATTERY	Not Tested	

10. Click the **Status** tab to review detected trouble conditions in any of the enrolled devices. The table displays the device number, Location Name, Zone Type, Device Type, Trouble Status, Received Signal Strength Indication of the last 24 hours and Partition numbers.

Configurator Dashboard Connect Alerts Status **History** Devices Keypad About

History

Group by date Sort by Description

Event#	Event Type	Date	Time	Zone/User#
Today				
72	Alarm Perimeter	9/11/2014	7:13:24 AM	Zone 5 Partition:2
6	Arm Away	9/11/2014	9:55:32 AM	Proxy 1 Partition:3
40	Arm Away	9/11/2014	8:41:45 AM	Keyfob 1 Partition:2
74	Arm Home	9/11/2014	7:12:35 AM	User 7 Partition:2
70	Cancel Alarm	9/11/2014	7:13:58 AM	User 7 Partition:2
44	Control Panel Low Battery	9/11/2014	8:33:53 AM	System

11. Click the **History** tab to review the events (up to 100) that the PowerMaster 360 control panel has detected. The table includes: event number; type of event; date and time of event; and relevant zone/user number and partition number. Select the “Group by date” or “Sort by Description” checkbox to display events according to event description or in chronological order.

Configurator Dashboard Connect Alerts Status History **Devices** Keypad About

Device Information

Custom Zone Add Device

<p>Zone 1 Front door</p> <p>RSSI 24H: Strong Battery: Ok O/C: N/A Enroll: Activated Partition: 1</p> <p>Camera 140-5223</p>	<p>Zone 15 Upstairs</p> <p>RSSI 24H: Strong Battery: Ok O/C: Close Enroll: Activated Partition: 1+2+3</p> <p>Contact+ 1 input 101-5329</p>	<p>Zone 16 Office</p> <p>RSSI 24H: Strong Battery: Ok O/C: Close Enroll: Activated Partition: 1</p> <p>Contact 100-7786</p>
<p>Keyfob 8</p> <p>RSSI 24H: No Result Battery: Ok O/C: N/A Enroll: Activated Partition: N/A</p> <p>Keyfob 234 300-3602</p>		

12. Click the **Devices** tab to review all pre-enrolled and enrolled (activated) devices, open/close state of detectors, received signal strength indication of the last 24 hours and battery status of devices. In addition, you can review and change the location of devices and delete devices.

The “Custom Zone” and “Add Device” buttons allow you to define custom location names and pre-enroll devices.

13. Click **Save All** after defining custom locations and pre-enrolling devices.

APPENDIX A. PowerMaster 360 Configurator

14. Click the **Keypad** tab to display the PowerMaster 360's Virtual Keypad. The Virtual Keypad enables access to the full USER MODE and INSTALLER MODE panel features. Use this keypad to perform all system setup and programming functions (for detailed instructions, see the *PowerMaster 360 Installer and Quick Guide*).

The Virtual Keypad supports **voice prompts**. To hear the prompts, adjust your PC's speaker volume.



15. The **About** tab displays the PowerMaster 360's serial number (Panel ID), its firmware versions and PowerLink version. In addition, here, you can review or change the Password used to gain access to PowerMaster 360 Installer Mode Menu.

16. Click **Save All** after changing Password.

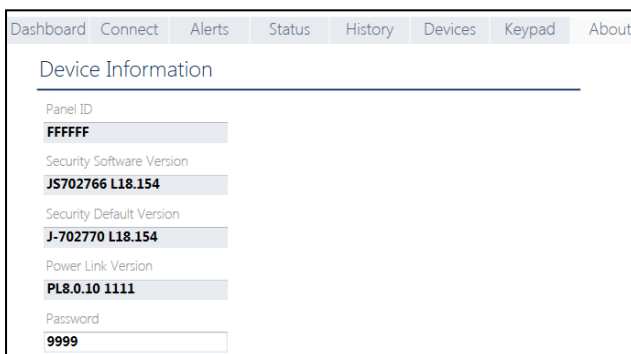

A2. Manually Installing the USB Driver

1. Connect the USB cable to the PowerMaster 360 and to the laptop; the following message will appear in the bottom right corner of the screen.
2. If installation is successful, the following message will appear. The screen below then opens.

Note: *ELMO GMAS (COMxx)* may appear instead of **Gadget Serial (COM3)** in both this message and in the screen below.

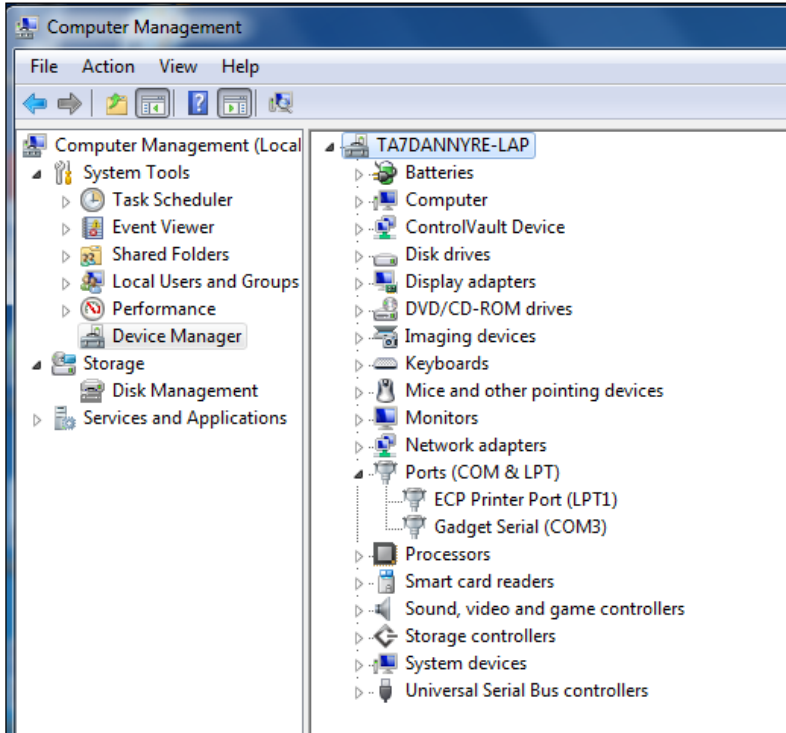
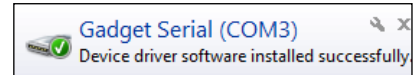

3. If Windows does not recognize the software during startup, the following message will appear:



APPENDIX A. PowerMaster 360 Configurator

4. In this case navigate to **Start → All Programs → Visonic Ltd** and save the “iMX6-multifunc--serial-win7.inf” file to a temporary folder. For example, T:/iMX6_Driver.

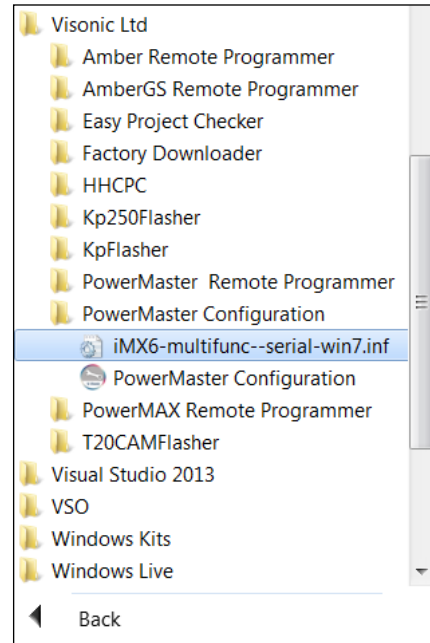

5. Navigate to the **Other devices** folder.

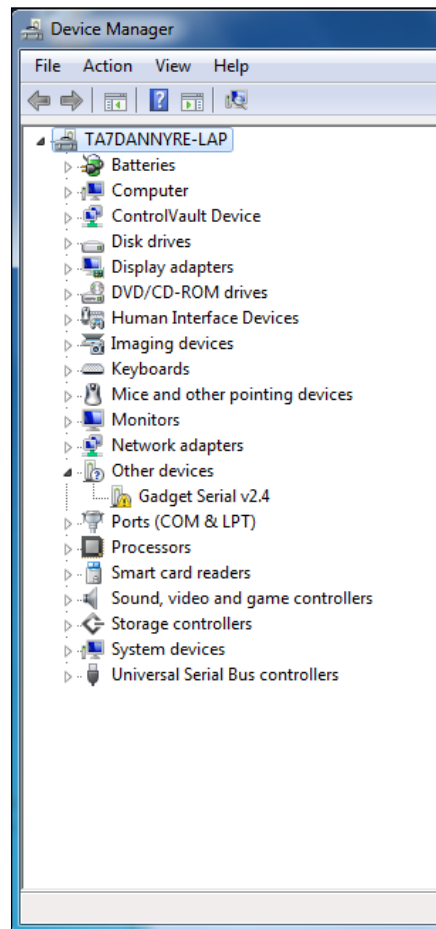

6. Right-click the **Gadget Serial vx.x** file and then select **Properties**; the following screen appears.
7. In the **General** tab, click the **Update Driver...** button; the screen below appears.

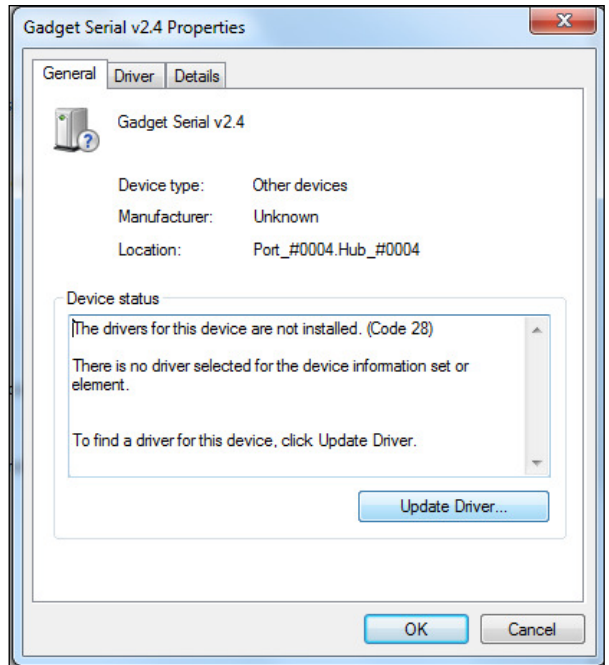

8. Select the **Browse my computer for driver software** option.

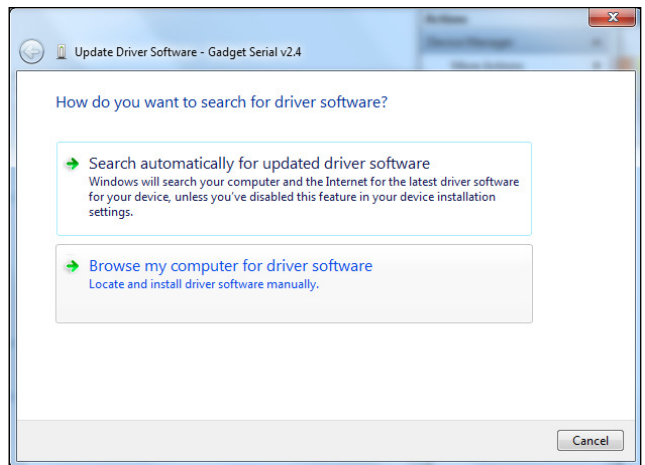

APPENDIX A. PowerMaster 360 Configurator

9. In the screen that opens, click **Browse** and then navigate to the temporary folder where the “iMX6-multifunc-serial-win7.inf” file was saved.
10. Select the folder and then click **OK**.

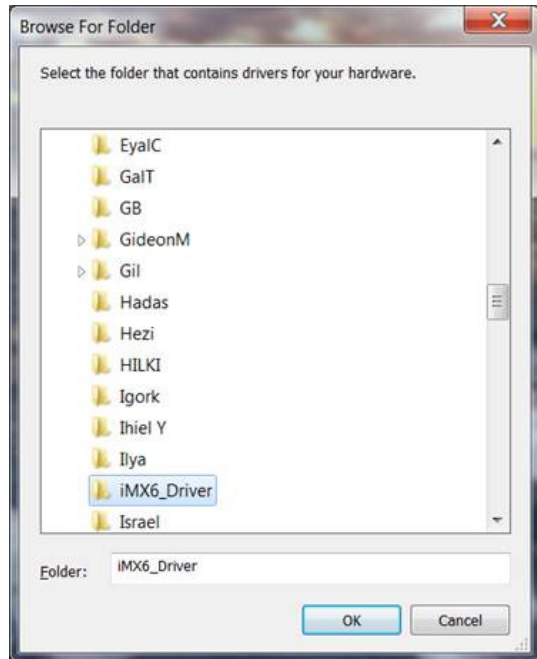

11. In the screen that opens, click **Next**.

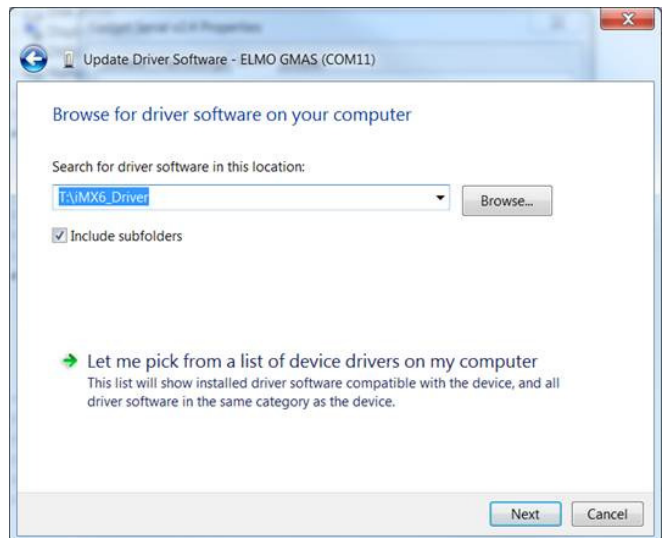

12. Windows now installs the driver software.

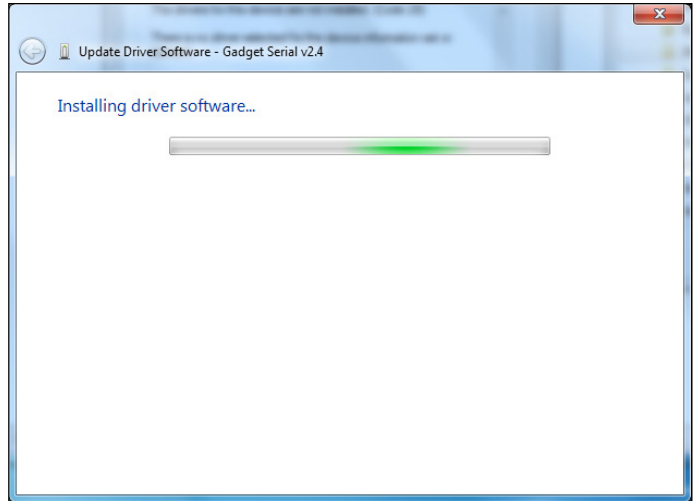

13. When Windows has successfully installed the driver software, the following screen will appear.

14. Click **Close**.

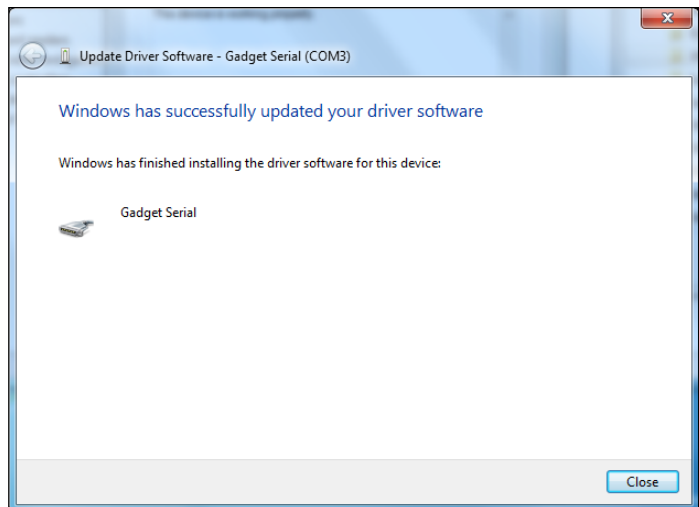

APPENDIX A. PowerMaster 360 Configurator

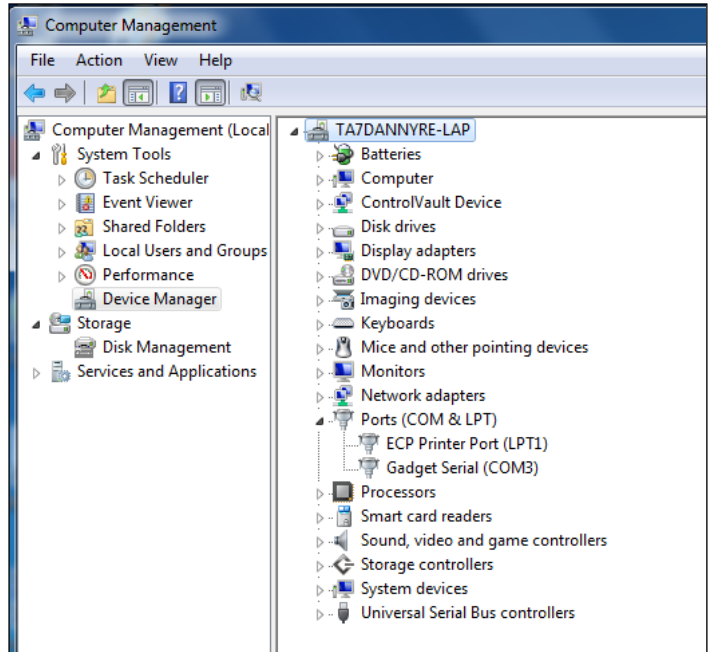

15. After concluding the procedure, the **Gadget Serial (COMxx)** port will appear on the right side of the following screen.





A3. Virtual Keypad Controls







LED Icons





Indication	Function
	Power
	Armed AWAY – LED lights steadily. HOME – LED blinks

Indication	Function
	Trouble
	Active service to the server





Control Keys

Indication	Function
	NEXT: Advance from item to item within a given menu.
	BACK: Move one step back within a given menu.
	UP: Use to move one level up in the menu or to return to previous setting step.
	OK: Review status messages one by one and also select a displayed option.

Arming Keys

Indication	Function
	AWAY: Arming when nobody is at home
	HOME: Arming when people remain at home.
	INSTANT: Canceling the entry delay upon arming (AWAY or HOME)
	DISARM / OFF: Disarming the system and stopping alarms

Other Keys

Indication	Function
	Chime ON/OFF
	Reviewing the event log
	Emergency
	Fire
	Panic

Note: The above buttons are identical in function to the corresponding buttons shown throughout the document.

APPENDIX B. VISONIConfig Mobile Installer App. For PowerMaster 360

B1. Working with the PowerMaster Configurator

The PowerMaster 360 VISONIConfig Mobile Application is used by installers to configure the PowerMaster 360 security system and provides an easy-to-use virtual keypad that allows you to fully control the panel configurations.

Note: *The Mobile Application operates on Android devices only.*

1. Install the VISONIConfig Application; the VISONIConfig Application's icon will appear on your desktop.
2. Click the icon to launch the application. The Welcome screen will shortly appear on your Android device screen.
3. Connect the USB cable to your Android device and to the micro USB connection of the PowerMaster 360 panel.



4. During the initialization process, the following screen will appear.



5. After connection to the device has been established, enter the Configurator Code in the **ENTER CONFIGURATION CODE** box.
6. Click the **LOGIN** button.

Notes:

- Select the **Remember Login Details** checkbox to remember the typed in Password for the next login.
- If the authentication process fails, an error message will appear. Disconnect the cable and then reconnect it.
- If you enter an incorrect Configuration Code, you will receive an invalid code message. Re-enter the code.

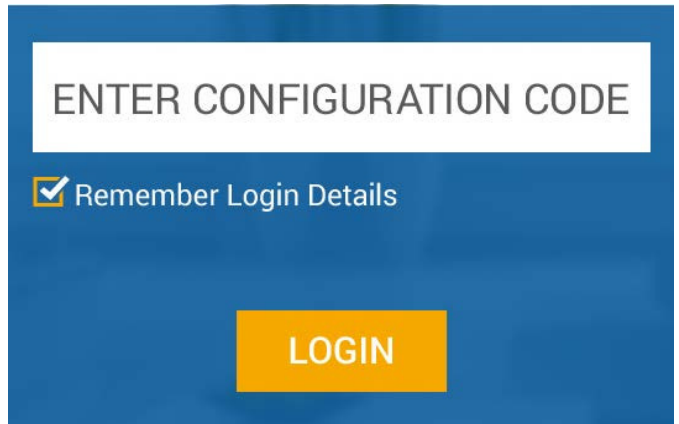

APPENDIX B. VISONIConfig Mobile Installer App. For PowerMaster 360

7. If the Configuration Code was entered correctly, the Virtual Keypad appears. The Virtual Keypad enables access to the full USER MODE and INSTALLER MODE panel features. Use this keypad to perform all system setup and programming functions (for detailed instructions, see the *PowerMaster 360 Installer and Quick Guide*).

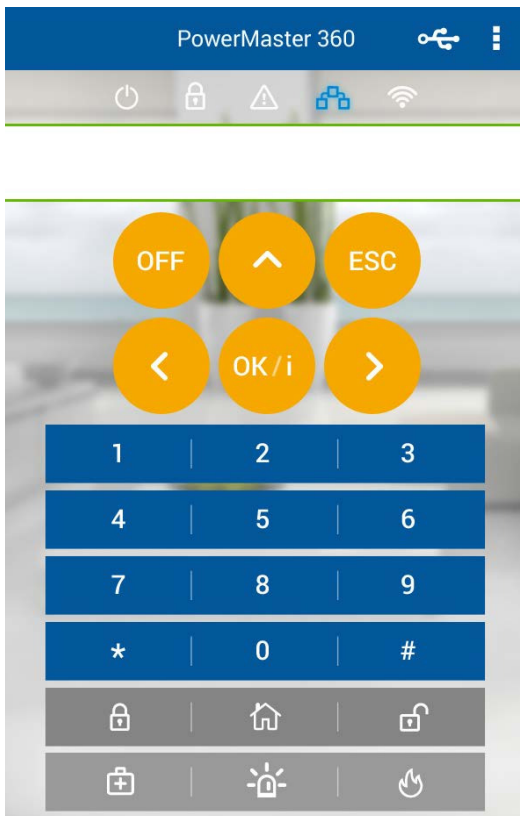

8. Click the drop-menu list button on the top right of the screen; the following options appear:

- **Setup:** Click the radio button to enable / disable the Virtual Keypad's beeps.
- **About:** Displays the Application version.
- **Logout:** Click to Logout.

Note: The  icon indicates one of the following:



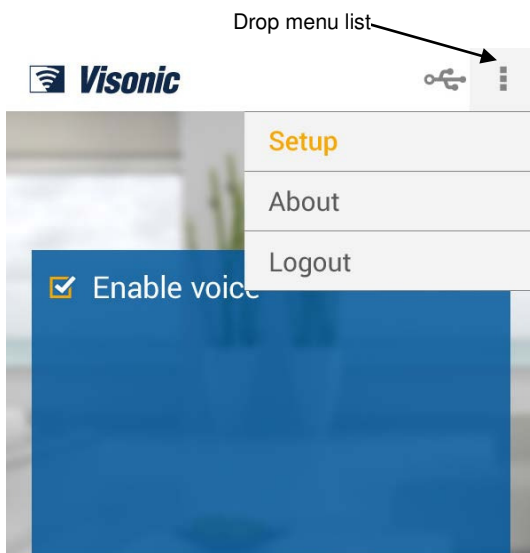

- **Green** – successful USB connection
- **Gray** – USB connection failure.

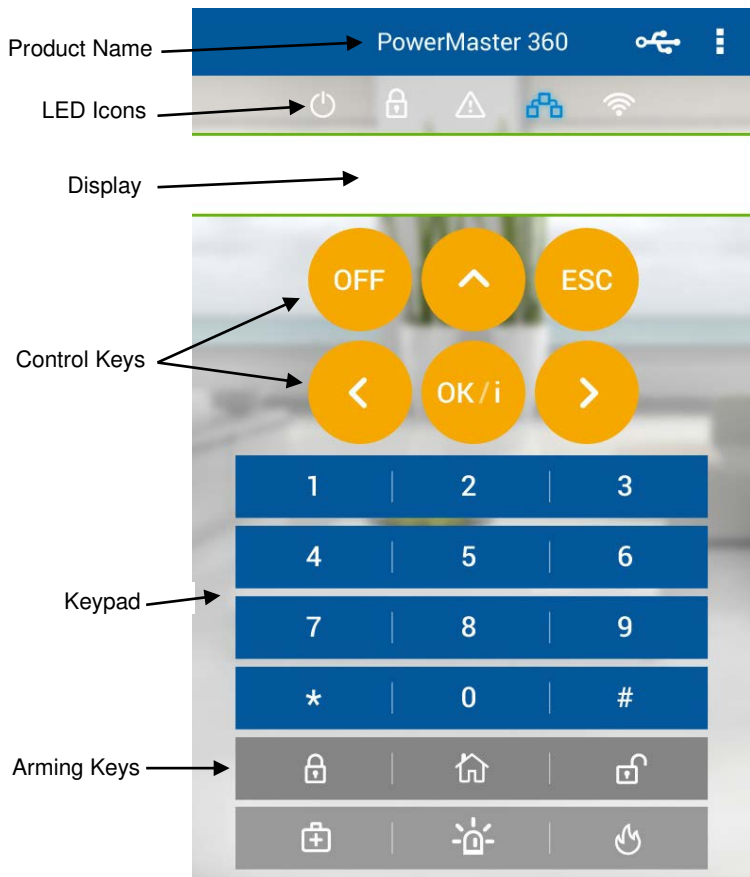

B2. VISONICConfig Controls





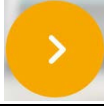
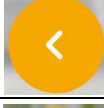
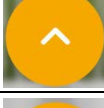
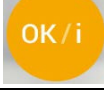

LED Icons

Indication	Function
	Power
	Armed AWAY – LED lights steadily. HOME – LED blinks
	Trouble
	Active service to the server
	WiFi connection





Control Keys

Indication	Function
	OFF: Delete a device
	NEXT: Advance from item to item within a given menu.
	BACK: Move one step back within a given menu.
	UP: Use to move one level up in the menu or to return to previous setting step.
	OK: Review status messages one by one and also select a displayed option.

Arming Keys

Indication	Function
	AWAY: Arming when nobody is at home
	HOME: Arming when people remain at home.
	INSTANT: Canceling the entry delay upon arming (AWAY or HOME)
	DISARM / OFF: Disarming the system and stopping alarms

Other Keys

Indication	Function
	Chime ON/OFF
	Reviewing the event log
	Emergency
	Fire
	Panic

Note: The above buttons are identical in function to the corresponding buttons shown throughout the document.

APPENDIX C. User Mobile Application with PowerMaster 360

C1. Security Only Via PowerManage

After establishing connection with the PowerManage server, the PowerMaster 360 appears as an entry in the PowerManage Panel List. The WEB Name is retrieved from the PowerMaster 360's Panel ID.

<input type="checkbox"/>	Panel ID	WEB Name	Account	Type	Group	↑	Modules	Events	GUI
<input type="checkbox"/>	991399	991399X	001234	PowerMaster 360	Main Group		G B	🚨 10	<input checked="" type="checkbox"/>

The home/property owner can access the PowerMaster 360 security system on a mobile device using the PowerManage Interactive app (for arming/disarming, viewing event details, etc.). The system's URL is [https://\[PowerManage server IP address\]/\[Panel's WEB Name\]](https://[PowerManage server IP address]/[Panel's WEB Name]).

For example: with a PowerManage on IP 100.101.102.103 using HTTPS communication and a panel with Panel_ID 140613. The link to this panel's web portal will be:

<https://100.101.102.103/140613>

C2. Security and Smart Home Via 3rd Party

The home/property owner can access the PowerMaster 360 security and smart home system on a mobile device using a 3rd Party app (for arming/disarming and switching on/off lights, A/C, etc.).

APPENDIX D. Specifications

D1. Functional

Zones Number	30 wireless zones
Installer and User Codes	<ul style="list-style-type: none"> • 1 master installer (9999 by default)* • 1 installer (8888 by default)* • 1 master user, no. 1 (1111 by default) • Users nos. 2 – 8 • Latchkey users 5 - 8 <p>* Codes must not be identical</p>
Control Facilities	Virtual keypad, wireless keyfobs and keypads
Arming Modes	AWAY, HOME, AWAY-INSTANT, HOME-INSTANT, FORCED, BYPASS.
Alarm Types	Silent, personal panic/emergency, burglary, gas (CO), and fire.
External Siren (bell) Timeout	Programmable (4 min. by default)
Supervision	Programmable time frame for inactivity alert
Special Functions	<ul style="list-style-type: none"> - Chime zones - Diagnostic test and event log. - Local and Remote Programming over Broadband and GPRS IP connections. - Calling for help by using an emergency transmitter. - Tracking inactivity of people.
Data Retrieval	Alarm memory, trouble, event log
Real Time Clock (RTC)	The control panel keeps and displays time and date. This feature is also used for the log file by providing the date and time of each event
Battery Test	Once every 10 seconds
PowerG Receiver Range	160 ft. (50 m) internal, 6500 ft. (2000 m) external
Connectors	<p>External:</p> <ul style="list-style-type: none"> • DC Power Jack • RJ-45 Ethernet Connector • Micro USB Connector <p>Internal:</p> <ul style="list-style-type: none"> • SIM Card Slot (part of GPRS Module) • Micro SD Card Slot • Battery Backup Connector

D2. Wireless

RF Network	PowerG – 2-way synchronized Frequency Hopping (TDMA / FHSS)		
Frequency bands (MHz)	433 – 434	868 - 869	912 – 919
Hopping frequencies	8	4	50
Region	Worldwide	Europe	North America and selected countries
Encryption	AES-128		
GSM (MHz)	2G Band		3G Band
	850, 900, 1800, 1900		850 ¹ , 900 ² , 1900 ¹ , 2100 ²
Z-Wave (MHz) (optional)	868.4, 908.4, 921.4		
WiFi - optional	2.4 GHz. Access Point is for IP camera support only		

¹ Covered by Module 2

² Covered by Module 1

D3. Electrical

External AC/DC adaptor	Input: AC 100-240V, 50/60 Hz, 0.4A Output: 5.1V DC 1.96A
Current Drain	Approx. 200 mA standby, 1200 mA peak at full load.
Low Battery Threshold	3.8 V
Backup Battery Pack	3.7 V, 1000 mAh LIPO
Backup Battery Time	4 Hrs
Time to Charge	80 % (~ 2 Hrs)

D4. Communication

Communication	IP, Ethernet 10/100
Monitoring Station Report	2 via PowerManage on IP and/or GPRS
Private Notifications	4 emails, 4 SMS numbers
Local Management Protocol to Windows PC and Android Mobile	USB
Report Destinations	2 Monitoring Stations, 4 private SMS telephones via the server and 4 emails
Reporting Format Options	SIA, Contact ID, SIA IP

D5. Physical Properties

Operating Temp. Range	32°F to 120°F (0°C to 49°C)
Storage Temp. Range	50°F to 122°F (10°C to 50°C)
Humidity	93% relative humidity, @ 30°C (86°F)
Size	158x114.5x36.5 mm (6.22x4.5x1.43 in.)
Weight	225g (8 Oz)
Color	White

D6. Peripherals and Accessory Devices

Modules – factory default (SKU)	Base (default): IP and PowerG GSM: 2G or 3G WiFi: 2.4 GHz Z-Wave: 500 Series
Additional wireless devices	30 detectors (includes 10 PIR cameras), 8 keyfobs, 8 keypads, 15 panic buttons, 8 proximity tags, 4 repeaters, and 4 wireless sirens (internal/external)
Wireless Devices and peripherals	Pendants: PB-101 PG2, PB-102 PG2 Magnetic Contact: MC-302 PG2, MC-302E PG2, MC-302EL PG2, MC-302V PG2 Motion Detectors: Next PG2; Next K9 PG2, TOWER-20 PG2, TOWER-32AM PG2, TOWER-32AM K9 PG2, TOWER-30AM PG2, TOWER-30AM K9 PG2, CLIP PG2, TOWER CAM PG2 PIR Camera Detectors: Next CAM PG2; Next CAM-K9 PG2 Note: A maximum of 10 PIR cameras are supported but only 5 cameras can take pictures simultaneously Smoke Detector: SMD-426 PG2, SMD-427 PG2 Keyfob: KF-234 PG2, KF-235 PG2 Keypad: KP-140 PG2/KP-141 PG2 (with proximity tag), KP-160 PG2 Indoor Siren: SR-720 PG2, SR-720B PG2 Outdoor Sirens: SR-730 PG2, SR-740 PG2, SR-740 HEX PG2 Repeater: RP-600 PG2 Gas: GSD-441 PG2, GSD-442 PG2 (CO detector) Glass-break: GB-501 PG2 Temperature: TMD-560 PG2 Flood: FLD-550 PG2, FLD-551 PG2 Shock: SD-304 PG2

APPENDIX E. Working with Partitions

Your alarm system is equipped with an integrated partitioning feature that can divide your alarm system into three distinct areas identified as Partition 1 through 3. A partition can be armed or disarmed regardless of the status of the other partitions within the system. Partitioning can be used in installations where shared security systems are more practical, such as a home office or warehouse building. When partitioned, each zone, each user code and many of your system's features can be assigned to Partition 1 to 3. Each user code is assigned with the list of partitions it is allowed to control in order to limit access of users to certain partitions.

When partitioning is enabled, menu displays are changed to incorporate the partition feature and also each device, user, and proximity tag has additional partitions menu, where it is assigned to certain partitions and excluded from others.

Note: When Partition Mode is disabled, all zones, user codes, and features of the control panel will operate as in a regular unit. When partition mode is enabled, all zones, user codes, and features of the control panel are automatically assigned to Partition 1.

E1. User Interface and Operation

Refer to the control panel User's Guide APPENDIX B. PARTITIONING for a detailed description of the user interface (Arming/Disarming, siren behavior, show function, etc.), and APPENDIX A for keyfobs and keypads operation in Partition Mode.

E2. Common Areas

Common areas are areas used as walkthrough zones to areas of 2 or more partitions. There may be more than one common area in an installation depending on the layout of the property. A common area is not the same as a partition; it cannot be armed / disarmed directly. Common areas are created when you assign a zone or zones to 2 or 3 partitions. Table A1 summarizes the behavior of the different zone types in a common area.

Table A1 – Common Area Definitions

Common area zone types	Definition
Perimeter	<ul style="list-style-type: none"> Acts as defined only after the last assigned partition is armed AWAY or HOME. In case that one of the partitions is disarmed, an alarm initiated from this zone is ignored for all assigned partitions.
Delay zones	<ul style="list-style-type: none"> Delay zones will not trigger an entry delay unless all assigned partitions are armed. It is, therefore, not recommended to define delay zones as common areas.
Perimeter follower	<ul style="list-style-type: none"> Act as defined only after the last assigned partition is armed AWAY or HOME. In case that one of the partitions is disarmed, an alarm initiated from this zone is ignored for all assigned partitions. In case that one of the common area assigned partitions is in a delay state (and the other partitions are armed), the alarm will behave as a perimeter follower for this partition only. The event will be ignored for other assigned armed partitions.
Interior	<ul style="list-style-type: none"> Acts as defined only after the last assigned partition is armed AWAY. In case that one of the partitions is disarmed or armed HOME, an alarm initiated from this zone is ignored for all assigned partitions.
Interior follower	<ul style="list-style-type: none"> Acts as defined only after the last assigned partition is armed AWAY. In case that one of the partitions is disarmed or armed HOME, an alarm initiated from this zone is ignored for all assigned partitions. In case that one of the common area assigned partitions is in a delay state (and the other partitions are armed), the alarm will behave as an interior follower for this partition only. The event will be ignored for other assigned armed partitions.
Home / Delay	<ul style="list-style-type: none"> Acts as a Perimeter-Follower type when all assigned partitions are armed AWAY. Acts as a Delay type when at least one of the assigned partitions is armed HOME. Will be ignored when at least one of the assigned partitions is disarmed.
Emergency; Fire; Flood; Gas; Temperature; 24-hour silent; 24-hour audible; Non-alarm	<ul style="list-style-type: none"> Always armed.

Note: A Soak Test of Common areas cannot be initiated when one of its partitions is armed. When Soak Test of a Common area is active, an alarm event is ignored unless all the partitions that are assigned to the zone are armed.

APPENDIX F. Detector Deployment & Transmitter Assignments

F1. Detector Deployment Plan

Zone No.	Zone Type		Location		Chime (melody Location) or Off (*)	Sensor Type	Holder
	Default	Programmed	Default	Programmed			
1	Exit/Entry 1		Front Door				
2	Inter-Follow		Living Room				
3	Exit/Entry 2		Attic				
4	Perimeter		Back Door				
5	Perimeter		Child Room				
6	Inter-Follow		Office				
7	Inter-Follow		Dining Room				
8	Perimeter		Dining Room				
9	Perimeter		Kitchen				
10	Perimeter		Living Room				
11	Inter-Follow		Living Room				
12	Inter-Follow		Bedroom				
13	Perimeter		Bedroom				
14	Perimeter		Guest Room				
15	Inter-Follow		Master Bedroom				
16	Perimeter		Master Bedroom				

Zone Types: 1 = Exit / Entry 1 * 2 = Exit / Entry 2 * 3 = Home Delay * 4 = Interior Follower * 5 = Interior * 6 = Perimeter * 7 = Perimeter Follower * 8 = 24hr Silent * 9 = 24hr Audible * 10 = Emergency * 11 = Arming Key * 12 = Non-Alarm * 17 = Guard * 18 = Outdoor.

Zone Locations: Note down the intended location for each detector. When programming, you may select one of 31 custom locations – see "02:ZONES/DEVICES" menu).

Notes:

All zones are chime off by default. Enter your own choice in the last column and program accordingly.

F2. Keyfob Transmitter List

Transmitter Data						AUX button Assignments	
No.	Type	Holder	No.	Type	Holder	Skip exit delay or Arming "instant"	
1			17			Indicate the desired function (if any)	
2			18				
3			19				
4			20				
5			21				
6			22				
7			23				
8			24				
9			25				
10			26				
11			27				
12			28				
13			29				
14			30				
15			31				
16			32				

Skip exit delay
 Arming "instant"

F3. Emergency Transmitter List

Tx #	Transmitter Type	Enrolled to Zone	Name of holder
1			
2			
3			
4			
5			
6			
7			
8			
9			
10			

F4. Non-Alarm Transmitter List

Tx #	Transmitter Type	Enrolled to Zone	Name of holder	Assignment
1				
2				
3				
4				
5				
6				
7				
8				
9				
10				

APPENDIX G. Event Codes

G1. Contact ID Event Codes

Code	Definition
101	Emergency
110	Fire
114	Heat
120	Panic
121	Duress
122	Silent
123	Audible
129	Confirm panic
131	Perimeter
132	Interior
133	24 Hour (Safe)
134	Entry/Exit
137	Tamper/CP
139	Burglary verified
140	General alarm
151	Gas alarm
152	Freezer alert
153	Freeze alert
154	Flood alarm
158	High temperature
159	Low temperature
180	Gas trouble
220	Guard sensor alarmed
301	AC loss
302	Low system battery
311	Battery disconnect
313	Engineer reset
321	Fuse
333	Expansion modem failure
344	RF receiver jam detect

Code	Definition
351	Telco fault
373	Fire detector trouble
374	Exit error alarm (zone)
350	Communication trouble
380	Sensor trouble
381	Inactive event
383	Sensor tamper
384	RF low battery
389	Sensor self-test failure
391	Sensor Watch trouble
393	Fire detector clean me
401	O/C by user
403	Auto arm
406	Cancel
408	Quick arm
412	Successful download/access
426	Door open event
441	Armed home
454	Fail to arm
455	Autoarm failed
456	Partial arm
459	Recent close event
570	Bypass
602	Periodic test report
607	Walk test mode
625	Time/Date change
627	Program mode entry
628	Program mode exit
641	Senior watch trouble

G2. SIA Event Codes

Code	Definition
AR	AC Restore
AT	AC Trouble
BA	Burglary Alarm
BB	Burglary Bypass
BC	Burglary Cancel
BJ	Burglary Trouble Restore
BR	Burglary Restore
BT	Burglary Trouble / Jamming
BV	Burglary Verified
BX	Burglary test
BZ	Inactive event
CF	Forced Closing
CG	Armed home
CI	Fail to Close
CL	Armed Away
CP	Auto Arm
CR	Recent Close
EA	Door Open
FA	Fire Alarm
FJ	Fire detector trouble
FR	Fire Restore

Code	Definition
LT	Phone Line Trouble
LX	Local Programming Ended
OP	Opening Report
OT	Fail to Arm
PA	Panic Alarm
PR	Panic Restore
QA	Emergency Alarm
RN	Engineer Reset
RP	Automatic Test
RS	Remote Program Success
RX	Manual Test
RY	Exit from Manual Test
TA	Tamper Alarm
TE	Communicator restored to operation
TR	Tamper Restore
TS	Communicator taken out of operation
UJ	Detector mask restore
UT	Detector mask
WA	Flood alarm
WR	Flood alarm restore
XR	Sensor Battery Restore

APPENDIX G. Event Codes

Code	Definition
FT	Fire Detector Clean
FX	Fire test
GA	Gas alarm
GJ	Gas trouble restore
GR	Gas alarm restore
GT	Gas trouble
GX	Gas test
HA	Holdup Alarm (duress)
JT	Time Changed
KA	Heat alarm
KH	Heat alarm restore
KJ	Heat trouble restore
KT	Heat trouble
LB	Local Program
LR	Phone Line Restore

Code	Definition
XT	Sensor Battery Trouble
YA	Fuse Fault
YH	Bell Restored
YI	Overcurrent Trouble
YM	System battery disconnect
YR	System Battery Restore
YT	System Battery Trouble / Disconnection
YX	Service Required
YZ	Service Completed
ZA	Freeze alert
ZH	Freeze alert restore
ZJ	Freezer alert restore
ZT	Freezer alert

G3. Understanding the Scancom Reporting Protocol Data Format

The SCANCOM data format consists of 13 decimal digits divided into 4 groups, from left to right, as shown on the right.

Each channel is associated with a specific event as follows:

- 1st "C": Fire
- 2nd "C": Personal attack
- 3rd "C": Intruder
- 4th "C": Open/close
- 5th "C": Alarm cancel
- 6th "C": Emergency
- 7th "C": Second alarm
- 8th "C": Trouble messages

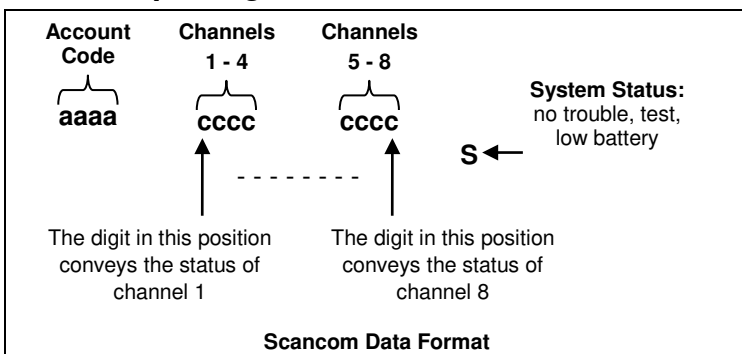

G4. SIA over IP - Offset for Device User

Type	Number Range In decimal	Example	Remarks
System reports	00	System tamper would report as 000	
Normal Zones/Detectors	1-499	Zone 5 would report as 005	
Keyfobs / Users /Tags	501-649	Keyfob/User number 101 would report 601	
Pendants	651-699	Pendant number 1 would report 651	
Keypads/ASU	701-799	Keypad number 8 would report 708	
Sirens	801-825	Siren number 9 would report 809	
Repeaters	831-850	Repeater number 4 would report 834	
Expanders/Bus devices	851-875	Device number 2 would report 852	
Troubles for:			
GSM	876	GSM module network fail 876	
BBA	877	BBA bus trouble 877	
Plink	878		
Guard	879		
	901- 999		For future use

APPENDIX H. Sabbath Mode

H1. General Guidance

The Sabbath Mode allows you to use the alarm system without violating the Sabbath. The basic feature of this alarm system is that the PIR sensors are not activated during Disarm mode.

The method of installation, as illustrated in the drawing below, is used in order to prevent transmission from the magnetic contact device. The MC-302E device is used only as a transmitting device to report the status of the door to the control panel. A wired magnetic contact is connected to the input of the MC-302E device and an open/close switch is connected in parallel to the MC-302E input.

Note: Before the Sabbath, closing the circuit neutralizes the detector's magnet. You can use the front door without violating the Sabbath. On the Sabbath day itself, you can open the switch to allow the door to be protected. This operation is permitted on the Sabbath and also when the control panel is armed.

H2. Connection

1. Enroll an MC-302E to the PowerMaster 360 control panel (see section 4.4.2).
2. Configure the "Input #1" setting option of the MC-302E to "Normally Closed" (refer to the MC-302E Installation Instructions, section 2.3).
3. Connect to the MC-302E a wired magnetic contact to be installed on the door and that is operated by opening/closing the door (see drawing below).
4. An open/close switch must be connected in parallel to the input of the MC-302E.

Wiring Setup

- A. MC-302E device
- B. Wired magnetic contact
- C. Fixed frame
- D. Moving part
- E. Open/close switch
 - E1. Closed
 - E2. Open

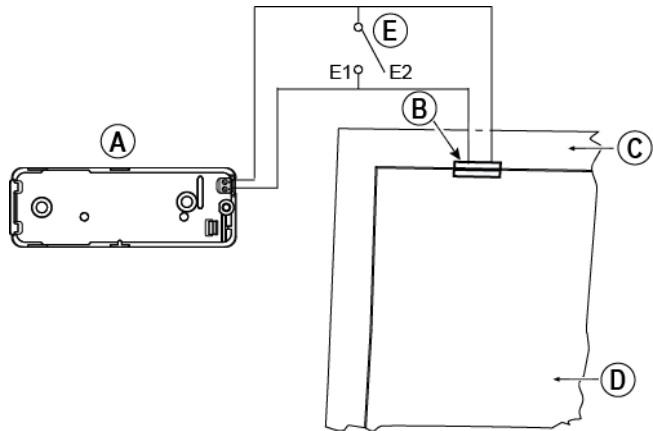

H3. Arming the System by Sabbath Clock

1. Enroll an MC-302E to the PowerMaster 360 control panel (see section 4.4.2).
2. Configure the Zone Type to "11.Arming Key" (see section 4.4.2)
3. Configure the "Input #1" setting option of the MC-302E to "Normally Open" (refer to the MC-302E Installation Instructions, section 2.3).
4. From the "03:CONTROL PANEL" menu, configure the "09:ARMING KEY" setting option to "arm HOME" (see section 4.5.2).

Note: When the alarm system is armed at night by a Sabbath clock, the open / close switch must be opened when the door is closed.

APPENDIX I. Glossary

Abort Period: When an alarm is initiated, the internal sounder is activated first for a limited period of time which is the abort period set by the installer. If you cause an alarm accidentally, you can disarm the system within the abort period before the real sirens start and before the alarm is reported to the *remote responders*.

Alarm: There are 2 kinds of alarms:

Loud alarm - the external siren blares out constantly and the control panel reports the event.

Silent alarm - the sirens remain silent, but the control panel reports the event.

A state of alarm is caused by:

- Motion detected by a *motion detector* (when the system is in the Armed state)
- Change of state detected by a *magnetic contact detector* - a closed window or door is opened
- Detection of smoke by a *smoke detector*, detection of gas by a *gas detector* and detection of water based fluids by a *flood detector* (when in any state).
- *Tampering* with any one of the detectors

Arming: Arming the alarm system is an action that prepares it to sound an alarm if a zone is "violated" by motion or by opening a door or window, as the case may be. The control panel may be armed in various modes (see *AWAY*, *HOME*, *INSTANT* and *LATCHKEY*).

Assigned: Refers to zones.

Associated: Refers to devices.

AWAY: This type of arming is used when the protected site is vacated entirely. All zones, *interior* and *perimeter* alike, are protected.

Chime Zones: Allow you to keep track of activity in the protected area while the alarm system is in the disarmed state. Whenever a chime zone is "opened", the buzzer beeps twice via the Configuration device (PC or mobile). The buzzer does not beep, however, upon closing the zone (return to normal). Residences can use this feature to announce visitors or look after children. Businesses can use it to signal when customers enter the premises or when personnel enter restricted areas.

Note: *Your installer will never designate a 24-hour zone or a fire zone as a chime zone, because both zone types actuate an alarm if disturbed while the system is in the disarmed state.*

Although one zone or more are designated as chime zones, you can still enable or disable the chime function.

Communicators: Refers to communication channel, for example, GSM.

Control Panel: The control panel is a cabinet that incorporates the electronic circuitry and microprocessor that control the alarm system. It collects information from various sensors, processes it and responds in various ways. It also includes the user-interface - control keys, numerical keypad, display, sounder and loudspeaker.

Default Settings: Settings that are applicable to a specific device group.

Detector: The device (apparatus) that sends an alarm, that communicates with the control panel (for example, Next PG2 is a motion detector; SMD-426 PG2 is a smoke detector).

Disarming: The opposite of arming - an action that restores the control panel to the normal standby state. In this state, only *fire* and *24-hour zones* will sound an alarm if violated, but a "*panic alarm*" may also be initiated.

Disturbed Zone: A zone in a state of alarm (this may be caused by an open window or door or by motion in the field of view of a motion detector). A disturbed zone is considered "not secured".

Forced Arming: When any one of the system zones is *disturbed* (open), the alarm system cannot be armed. One way to solve this problem is to find and eliminate the cause for zone disturbance (closing doors and windows). Another way to deal with this is to impose **forced arming** - automatic de-activation of zones that are still *disturbed* upon termination of the exit delay. Bypassed zones will not be protected throughout the arming period. Even if restored to normal (closed), bypassed zones will remain unprotected until the system is disarmed. Permission to "force arm" is given or denied by the installer while programming the system.

HOME: This type of arming is used when people are present within the protected site. A classic example is night-time at home, when the family is about to retire to bed. With HOME arming, perimeter zones are protected but interior zones are not. Consequently, motion within interior zones will be ignored by the control panel, but disturbance of a perimeter zone will cause an alarm.

Instant: You can arm the system AWAY-INSTANT or HOME-INSTANT, thereby canceling the entry delay for all delay zones for the duration of one arming period.

For example, you may arm the control panel in the HOME-INSTANT mode and remain within the protected area. Only perimeter protection is active, and if you do not expect somebody to drop in while the system is armed, alarm upon entry via the main door is an advantage.

To disarm the system without causing an alarm, use your control keypad (which is normally accessible without disturbing a perimeter zone) or use a keyfob transmitter.

Latchkey: The Latchkey mode is a special arming mode in which designated "latchkey users" will trigger a "latchkey message" to be sent to a telephone when they disarm the system.

For example, if a parent wants to be sure that their child has returned from school and disarmed the system. Latchkey arming is only possible when the system is armed in the AWAY mode.

Location: Assigning a named location to a device (for example, Garage, Front Door etc.)

Magnetic Contact Detector, Wireless: A Magnet- controlled switch and a wireless PowerG transmitter in a shared housing. The detector is mounted on doors and windows to detect changes in state (from closed to open and vice versa). Upon sensing that a door or window is open, the detector transmits its unique identification code accompanied by an “alarm” signal and various other status signals to the control panel. The control panel, if not armed at that time, will consider the alarm system as “not ready for arming” until it receives a “restored” signal from the same detector.

Motion Detector, Wireless: A passive Infrared motion sensor and a wireless PowerG transmitter in a shared housing. Upon sensing motion, the detector transmits its unique identification code, accompanied by an alarm signal and various other status signals to the control panel. After transmission, it stands by to sense further motion.

Non-Alarm Zone: Your installer can designate a zone for roles other than alarm. For instance, a motion detector installed in a dark stairway may be used to switch on lights automatically when someone crosses the dark area. Another example is a wireless transmitter linked to a zone that controls a gate opening mechanism.

Quick Arming: Arming without a user code. The control panel does not request your user code when you press one of the arming buttons. Permission to use this arming method is given or denied by the installer while programming the system.

Remote Responder: A responder can be either a professional service provider to which the home or business owner subscribes (a *Monitoring Station*) or a family relation/friend who agrees to look after the protected site during absence of its occupants. The *control panel* reports events by telephone to both kinds of responders.

Restore: When a detector reverts from the state of alarm to the normal standby state, it is said to have been “restored”. A *motion detector* restores automatically after detection of movement, and becomes ready to detect again. This kind of “restore” is not reported to the remote *responders*.

A *magnetic contact detector* restores only upon closure of the protected door or window. This kind of “restore” is reported to the remote *responders*.

Sensor: The sensing element: pyroelectric sensor, photo-diode, microphone, smoke optical sensor etc.

Signal Strength: The quality link communication between the system components and the control panel.

Smoke Detector, Wireless: A regular smoke detector and a wireless PowerG transmitter in a shared housing. Upon detection of smoke, the detector transmits its unique identification code accompanied by an alarm signal and various status signals to the *control panel*. Since the smoke detector is linked to a special *fire zone*, a fire alarm is initiated.

State: AWAY, HOME, AWAY-INSTANT, HOME-INSTANT, LATCHKEY, FORCED, BYPASS.

Status: AC fail, low battery, trouble, etc.

User Codes: The PowerMaster 360 is designed to obey your commands, provided that they are preceded by a valid security access code.

Unauthorized people do not know this code, so any attempt on their part to *disarm* or defeat the system is bound to fail. Some operations, however, can be carried out without a user code as they do not degrade the security level of the alarm system.

Virtual Keypad: Contains the user-interface - control keys, numerical keypad and display.

Zone: A zone is an area within the protected site under supervision of a specific detector. During programming, the installer allows the *control panel* to learn the detector’s identity code and links it to the desired zone. Since the zone is distinguished by number and name, the control panel can report the zone status to the user and register in its memory all the events reported by the zone detector. Instant and delay zones are “on watch” only when the control panel is armed, and other (*24-hour*) *zones* are “on watch” regardless of whether the system is armed or not.

Zone Type: The zone type determines how the system handles alarms and other signals sent from the device.

APPENDIX J. Compliance with Standards

Compliance with Standards



Hereby, Visonic Group declares that the PowerG series of central units and accessories are designed to comply with:

- **U.S. Standards:** (FCC) CFR 47 part 15
- **Canada Standards:** RSS 210
- **European CE Standards:** EN 300220, EN 300328, EN 301489, EN 50130-4, EN 60950

The PowerMaster 360 complies with the RTTE requirements - Directive 1999/5/EC of the European Parliament and of the Council of 9 March 1999.

WARNING! Changes or modifications to this unit not expressly approved by the party responsible for compliance (Visonic Ltd.) could void the user's authority to operate the equipment.

This device complies with FCC Rules Part 15 and with Industry Canada licence-exempt RSS standard(s). Operation is subject to two conditions: (1) This device may not cause harmful interference, and (2) this device must accept any interference that may be received or that may cause undesired operation.

Le présent appareil est conforme aux CNR d'Industrie Canada applicables aux appareils radio exempts de licence. L'exploitation est autorisée aux deux conditions suivantes : (1) l'appareil ne doit pas produire de brouillage, et (2) l'utilisateur de l'appareil doit accepter tout brouillage radioélectrique subi, même si le brouillage est susceptible d'en compromettre le fonctionnement.

NOTE: This equipment has been tested and found to comply with the limits for a Class B digital device, pursuant to part 15 of the FCC Rules. These limits are designed to provide reasonable protection against harmful interference in a residential installation. This equipment generates, uses and can radiate radio frequency energy and, if not installed and used in accordance with the instructions, may cause harmful interference to radio communications. However, there is no guarantee that interference will not occur in a particular installation. If this equipment does cause harmful interference to radio or television reception, which can be determined by turning the equipment off and on, the user is encouraged to try to correct the interference by one or more of the following measures:

- Reorient or relocate the receiving antenna.
- Increase the separation between the equipment and receiver.
- Connect the equipment into an outlet on a circuit different from that to which the receiver is connected.
- Consult the dealer or an experienced radio/TV technician for help.

Cet équipement a été testé et jugé conforme aux limites s'appliquant à un appareil numérique de classe B, conformément à la Partie 15 des réglementations de la FCC. Ces limites ont été élaborées pour offrir une protection raisonnable contre les interférences nuisibles dans une installation résidentielle.

Cet équipement génère, utilise et peut émettre de l'énergie de fréquence radio et, s'il n'est pas installé et utilise conformément aux instructions du fabricant, peut provoquer des interférences dangereuses pour les communications radio. Toutefois, rien ne garantit l'absence d'interférences dans une installation particulière. Si cet équipement provoque des interférences nuisibles au niveau de la réception radio ou télévision, ce qui peut être déterminé par la mise hors, puis sous tension de l'équipement, vous êtes invité à essayer de corriger les interférences en prenant les mesures suivantes:

- Réorientez ou déplacez l'antenne réceptrice.
- Augmentez la distance qui sépare l'équipement et le récepteur.
- Branchez l'équipement à une prise d'un circuit différent de celui auquel est branché le récepteur.
- Consultez le revendeur ou un technicien radio/télévision expérimenté pour obtenir de l'aide.

Industry Canada Declaration

This product meets the applicable Industry Canada technical specifications/Le présent matériel est conforme aux spécifications techniques applicables d'Industrie Canada.

WARRANTY

Visonic Limited (the "Manufacturer") warrants this product only (the "Product") to the original purchaser only (the "Purchaser") against defective workmanship and materials under normal use of the Product for a period of twelve (12) months from the date of shipment by the Manufacturer.

This Warranty is absolutely conditional upon the Product having been properly installed, maintained and operated under conditions of normal use in accordance with the Manufacturers recommended installation and operation instructions. Products which have become defective for any other reason, according to the Manufacturers discretion, such as improper installation, failure to follow recommended installation and operational instructions, neglect, willful damage, misuse or vandalism, accidental damage, alteration or tampering, or repair by anyone other than the manufacturer, are not covered by this Warranty.

The Manufacturer does not represent that this Product may not be compromised and/or circumvented or that the Product will prevent any death and/or personal injury and/or damage to property resulting from burglary, robbery, fire or otherwise, or that the Product will in all cases provide adequate warning or protection. The Product, properly installed and maintained, only reduces the risk of such events without warning and it is not a guarantee or insurance that such events will not occur.

THIS WARRANTY IS EXCLUSIVE AND EXPRESSLY IN LIEU OF ALL OTHER WARRANTIES, OBLIGATIONS OR LIABILITIES, WHETHER WRITTEN, ORAL, EXPRESS OR IMPLIED, INCLUDING ANY WARRANTY OF MERCHANTABILITY OR FITNESS FOR A PARTICULAR PURPOSE, OR OTHERWISE. IN NO CASE SHALL THE MANUFACTURER BE LIABLE TO ANYONE FOR ANY CONSEQUENTIAL OR INCIDENTAL DAMAGES FOR BREACH OF THIS WARRANTY OR ANY OTHER WARRANTIES WHATSOEVER, AS AFORESAID.

THE MANUFACTURER SHALL IN NO EVENT BE LIABLE FOR ANY SPECIAL, INDIRECT, INCIDENTAL, CONSEQUENTIAL OR PUNITIVE DAMAGES OR FOR LOSS, DAMAGE, OR EXPENSE, INCLUDING LOSS OF USE, PROFITS, REVENUE, OR GOODWILL, DIRECTLY OR INDIRECTLY ARISING FROM PURCHASER'S USE OR INABILITY TO USE THE PRODUCT, OR FOR LOSS OR DESTRUCTION OF OTHER PROPERTY OR FROM ANY OTHER CAUSE, EVEN IF MANUFACTURER HAS BEEN ADVISED OF THE POSSIBILITY OF SUCH DAMAGE.

THE MANUFACTURER SHALL HAVE NO LIABILITY FOR ANY DEATH, PERSONAL AND/OR BODILY INJURY AND/OR DAMAGE TO PROPERTY OR OTHER LOSS WHETHER DIRECT, INDIRECT, INCIDENTAL, CONSEQUENTIAL OR OTHERWISE, BASED ON A CLAIM THAT THE PRODUCT FAILED TO FUNCTION.

However, if the Manufacturer is held liable, whether directly or indirectly, for any loss or damage arising under this limited warranty, **THE MANUFACTURER'S MAXIMUM LIABILITY (IF ANY) SHALL NOT IN ANY CASE EXCEED THE PURCHASE PRICE OF THE PRODUCT**, which shall be fixed as liquidated damages and not as a penalty, and shall be the complete and exclusive remedy against the Manufacturer.

When accepting the delivery of the Product, the Purchaser agrees to the said conditions of sale and warranty and he recognizes having been informed of.

Some jurisdictions do not allow the exclusion or limitation of incidental or consequential damages, so these limitations may not apply under certain circumstances.

The Manufacturer shall be under no liability whatsoever arising out of the corruption and/or malfunctioning of any telecommunication or electronic equipment or any programs.

The Manufacturers obligations under this Warranty are limited solely to repair and/or replace at the Manufacturer's discretion any Product or part thereof that may prove defective. Any repair and/or replacement shall not extend the original Warranty period. The Manufacturer shall not be responsible for dismantling and/or reinstallation costs. To exercise this Warranty the Product must be returned to the Manufacturer freight pre-paid and insured. All freight and insurance costs are the responsibility of the Purchaser and are not included in this Warranty.

This warranty shall not be modified, varied or extended, and the Manufacturer does not authorize any person to act on its behalf in the modification, variation or extension of this warranty. This warranty shall apply to the Product only. All products, accessories or attachments of others used in conjunction with the Product, including batteries, shall be covered solely by their own warranty, if any. The Manufacturer shall not be liable for any damage or loss whatsoever, whether directly, indirectly, incidentally, consequentially or otherwise, caused by the malfunction of the Product due to products, accessories, or attachments of others, including batteries, used in conjunction with the Products. This Warranty is exclusive to the original Purchaser and is not assignable.

This Warranty is in addition to and does not affect your legal rights. Any provision in this warranty which is contrary to the Law in the state or country where the Product is supplied shall not apply.

Warning: The user must follow the Manufacturer's installation and operational instructions including testing the Product and its whole system at least once a week and to take all necessary precautions for his/her safety and the protection of his/her property.

1/08



Visonic

EMAIL:

info@visonic.com

INTERNET:

www.visonic.com

©VISONIC LTD. 2015

PowerMaster 360 Installer's Guide D-305735 Rev 1 (11/15)

Based on D-304828 Rev 0



D-305735

PowerMaster 360 Quick User Guide

Arming and Disarming the System

Step	Operation	User Actions	Notes
Optional	1 Press the Partition Selection button and then select a PARTITION (if Partition is enabled) – used to divide the alarm system into three independently controllable areas	# followed by any combination of , , or	A “protest” beep will be heard when selecting a partition to which no sensors / peripherals were enrolled.
	2 Arm AWAY - used to arm the system when the protected site is vacated entirely. Arm HOME – used to arm the system when people are present within the protected site. Disarm (OFF) – used to restore the control panel to the normal standby state	+ or enter code + or enter code + or enter code	ARM indicator lights steadily during the armed state. ARM indicator extinguishes during the disarmed state.
Optional	Quick arm AWAY (If Quick Arm is enabled) – used to arm in the AWAY state without a user code		Disarming the system also stops the siren alarm, irrespective of whether the alarm was initiated during the armed or the disarmed state.
	Quick arm HOME (If Quick Arm is enabled) – used to arm in the HOME state without a user code		
	Forced arming AWAY (system not ready) – used to arm the alarm system in the AWAY state when any of the system zones is disturbed	+ or enter code to silence the “protest” buzzer	
	Forced arming HOME (system not ready) – used to arm the alarm system in the HOME state when any of the system zones is disturbed	+ or enter code to silence the “protest” buzzer	
Optional	3 INSTANT – used to arm in the Instant mode, without an entry delay. LATCHKEY – used for keyfob transmitters 5 through 8	(After arming HOME/AWAY) 	

Note: The factory default master user code is 1111. The code is not required if quick arming has been permitted by the installer. Change the factory default code to a secret code without delay (see section Chapter 4, section B.4 of the PowerMaster 360 User’s Guide).

Initiating Alarms

Alarms	Actions	Notes
Emergency alarm	(≈ 2 sec.)	To stop the alarm, press and then key in your valid user code.
Fire alarm	(≈ 2 sec.)	
Panic alarm	+ (≈ 2 sec.)	

Preparing to Arm



Before arming, make sure that READY is displayed.

This indicates that all zones are secured and you may arm the system as desired.

If at least one zone is open (disturbed) the display will read:

This indicates that the system is not ready for arming and in most cases that one or more zones are not secured. However, it can also mean that an unresolved condition exists such as certain trouble conditions, jamming etc., depending on system configuration.

PowerMaster 360 Quick User Guide

To review the open zones click . The details and location of the first open zone detector (usually an open door or window sensor) will be displayed. To fix the open zone, locate the sensor and secure it (close the door or window) – see "device locator" below. Each click of  will display another open zone or trouble indication. It is highly recommended to fix the open zone(s), thus restoring the system to the state of "ready to arm". If you do not know how to do this, consult your installer.

Note: To quit at any stage and to revert to the "READY" display, click .

Device Locator: The PowerMaster 360 system has a powerful device locator that helps you to identify open or troubled devices indicated on the LCD display. While the LCD displays an open or faulty device, the LED on the respective device flashes indicating "it's me". The "it's me" indication will appear on the device within max. 16 seconds and will last for as long as the LCD displays the device.

Zone Bypass Scheme

Bypassing permits arming only part of the system and at the same time allowing free movement of people within certain zones when the system is armed. It is also used to temporarily remove from service faulty zones that require repair work or to deactivate a sensor if, for example, you are decorating a room.

You can set the Zone Bypass Scheme i.e. to scroll through the list of registered (enrolled) sensors to your PowerMaster 360 system and to Bypass (deactivate) faulty or disturbed sensors (either READY or NOT-READY) or to Clear (reactivate) BYPASSED zones (sensors).

Once you have set a Bypass Scheme you can use the following 3 options:

- To quickly clear a bypassed zone i.e. to reactivate the bypassed zone – refer to Chapter 4, section B.1 of the PowerMaster 360 User's Guide.
- To quickly review the bypassed zones – refer to Chapter 4, section B.2 of the PowerMaster 360 User's Guide.
- To repeat (recall) the last used zone bypassing scheme – refer to Chapter 4, section B.3 of the PowerMaster 360 User's Guide.