

SPD-1000

Wireless Magnetic Displacement Detector

SpiderAlert®

Installation Instructions

1. INTRODUCTION

SPD-1000 is a fully supervised wireless detector, designed for protection of paintings, sculptures and other artwork, in museums, galleries, churches, private artwork collections, etc.

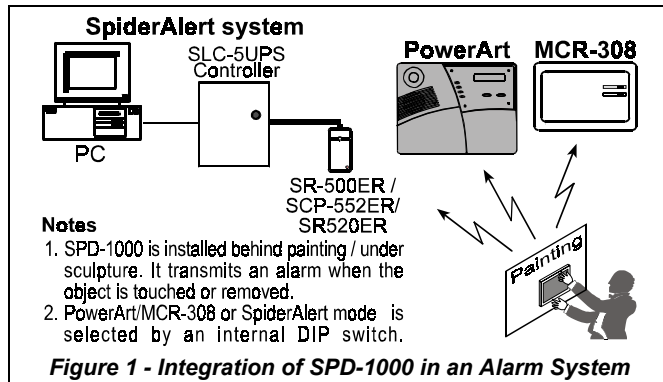

When someone tries to touch or remove the secured object, to which the detector is attached, an identifiable alarm signal is transmitted to alert security personnel. Identifiable signals include: low battery voltage alert, low severity alarm (slight touch) and high severity alarm (repetitive touch, strong touch or removal).

In addition, the detector periodically sends supervision signal as a serviceability report. With PowerArt high level, sensitivity can be extended.

The detector has 3 modes:

- A. "Sleep" - for the detector transport or long term storage, without causing an alarm. In this mode the current consumption is very low.
- B. "Installation" - for sensor's spring active range adjustment and for teaching the SpiderAlert / PowerArt system the detector's identity.
- C. "Operation".

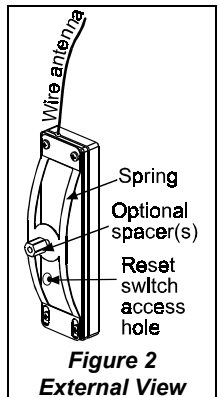

All mode changes and alarms are aurally indicated by an integral buzzer.

The SPD-1000 has tracking mode (for SpiderAlert only) that enables to track the secured object's location up to 10 minutes after its removal (with SpiderAlert receivers deployed within the site). This option is possible if the detector is attached to the secured object.

For a large painting, several SPD-1000 units can be used.

2. SPECIFICATIONS

Movement Detection Sensitivity: 0.1 mm

Transmission Frequency (MHz): 315 or 433.92

Compatible Receivers: PowerArt / MCR-308, SpiderAlert SR-500ER / SCP-532ER / SR-520ER.

Overall Message Length: 36 bits, including 24-bit identification code, pulse width modulation.

Supervision Transmission: Every 60 min. (USA) / 15 min. (Europe)

Power Source: Two 3V/160 mAh Lithium batteries, GP CR-2025, or equivalent.

Current Consumption: 8 µA (STBY), 8 mA (transmission)

Battery Life: 5 years under normal installation conditions

Battery Supervision: Automatic transmission of battery condition data as part of any status report.

Tracking Transmission: Every 30 sec., while the secured object is being moved from its original place, up to 10 min. after last movement.

Operating Temperatures: 0°C to 50°C (32°F to 122°F)

Dimensions (HxWxD): 96 x 28 x 22 mm (3-13/16 x 1-1/8 x 7/8 in.)

Weight (with battery): 34.8 g (1.2 oz)

Color: Housing - white, spring - nickel

Compliance with Standards: FCC part 15, IC:1467102181. The term "IC" before the certification/registration number only signifies that the Industry Canada technical specifications were met.

3. INSTALLATION

3.1 Installation Options

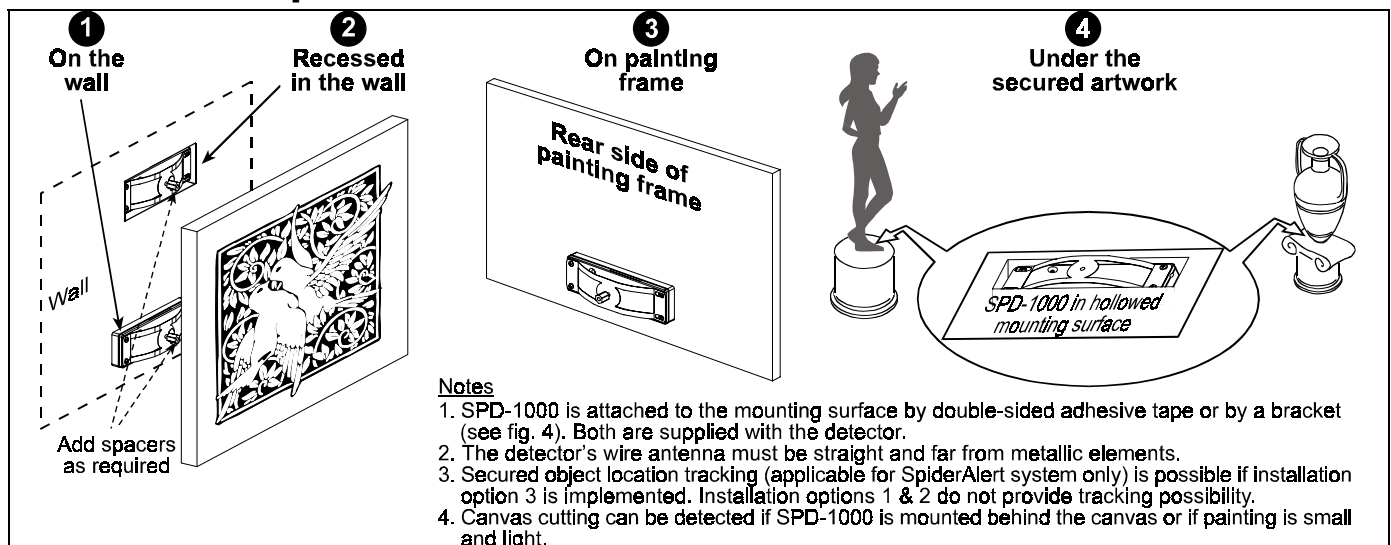

Figure 3 - Installation Possibilities

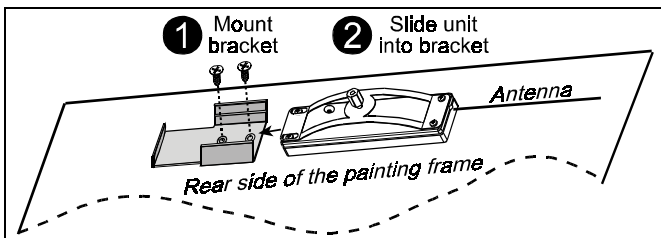

Figure 4 - Using a Bracket to Attach the Detector

Attention!

Before detector installation:

1. Remove spring movement prevention sticker (see fig. 5).
2. Remove protective non-metallic spacer that keeps the spring in the "sleep" mode (shown in par. 3.7).

3.2 Setting the SMD Switches

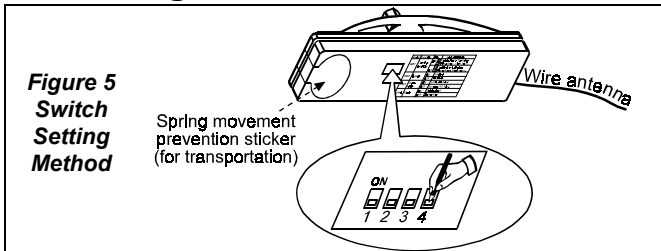
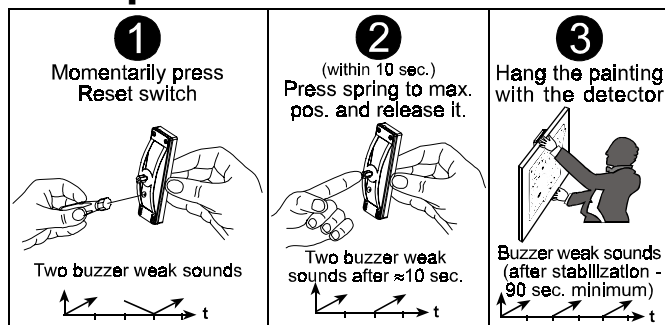

Table 1 - SMD Switches Functions

Switch	Function	Pos.	Selected Option	Default
SW. 1	Sensitivity & tracking	ON	Spider: Tracking enabled PowerArt: High sensitivity	ON
		OFF	Spider: Tracking disabled PowerArt: Low Sensitivity	
SW. 2	Buzzer	ON	Enabled	ON
		OFF	Disabled	
SW. 3	Supervision	ON	USA (60 Min.)	ON
		OFF	Europe (15 Min.)	
SW. 4	Mode	ON	SpiderAlert	ON
		OFF	PowerArt or MCR-308	

3.3 Preparation for Use



3.4 Teaching PowerArt / MCR-308

Teach PowerArt / MCR-308 to identify SPD-1000:

- A. Teach PowerArt (see par. 3.2G in PowerArt Prog. Guide) or MCR-308 (see par. 3.5 in MCR-308 installation instructions). When instructed to transmit, initiate SPD-1000 low severity alarm transmission by momentarily pressing the Reset switch (see illustration 1 in par. 3.3).

Note: According to this signal, the PowerArt automatically learns to identify high severity alarm, low severity alarm, low battery and supervision messages. According to this signal the MCR-308 learns to identify low severity alarm only.

To teach the MCR-308 the high severity alarm, create the alarm after the detector has been stabilized, by strong movement / removal of the secured object.

- B. Verify that the teaching is successful, according to the previously mentioned documents.

3.5 Teaching the SpiderAlert System

Teach SpiderAlert system to identify SPD-1000 transmissions:

- A. In SpiderAlert software Click File/Transmitters/Museum/Add.
- B. Initiate low severity alarm transmission by momentarily pressing Reset switch (see par. 3.3, step 1).
- C. The detector's ID number will be displayed in the yellow box.
- D. Press the "<<" button to move the ID number from the yellow (temporary) box to the "ID" box.
- E. In the Location box, type the secured object's name (i.e. Mona Liza picture).
- F. In Holder Group box, type a desired name for the museum detectors group for whom the event handling will be identical.
- G. Press the button, to display the Museum Group screen.
- H. Select the appropriate museum detectors group.
- I. Press Edit button, define (for the operator) the handling description for every detector's event and press OK.

3.6 Operation

SPD-1000 function is based on magnetic field changes as a result of the secured object movements. The detector has 2 detection levels - low severity alarm (continuous slight touch) and high severity alarm (strong touch or removal).

Once stabilized, the detector checks its position continuously. Upon a movement detection, the detector sends alarm as follows:

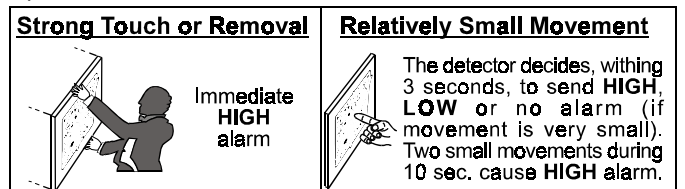

Note: After HIGH alarm only, the detector needs 90-second stabilization period at least, for the next movement detection.

When Low or High level alarm is transmitted, 2 weak buzzer sounds are heard, as shown.

3.7 Entering the "Sleep" Mode

Entering Sleep mode (for description, see section 1) is as follows:

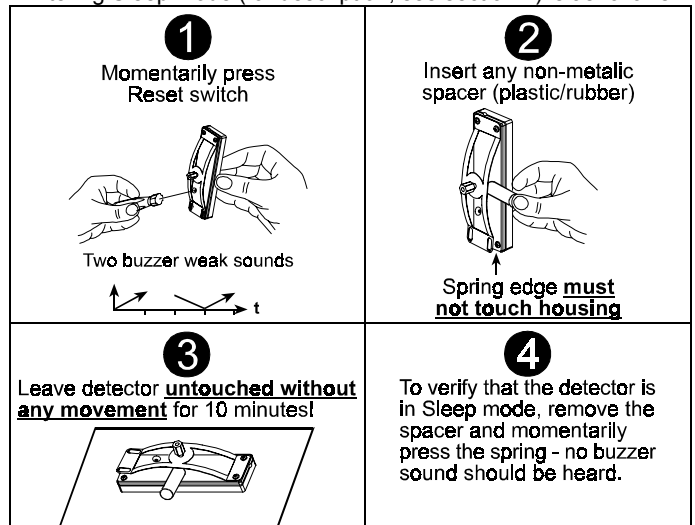

Compliance with Standards

This device complies with FCC Rules Part 15. Operation is subject to two conditions: (1) This device may not cause harmful interference, and (2) this device must accept any interference that may be received or that may cause undesired operation. The user is cautioned that changes or modifications to the unit, not expressly approved by Visonic Ltd., could void the user's FCC or other authority to operate the equipment. The 315 MHz is for USA & Canada - not allowed in any EU member state. The 433.92 MHz has no restriction in any EU member state.



VISONETIX LTD. (ISRAEL): P.O.B 22020 TEL-AVIV 61220 ISRAEL. PHONE: (972-3) 645-6890, FAX: (972-3) 645-6891

VISONIC SYSTEMS INC. (U.S.A.): 10 NORTHWOOD DRIVE, BLOOMFIELD CT. 06002-1911. PHONE: (860) 242-9945, (800) 874-3989 FAX: (860) 242-0191

VISONIC LTD. (UK): UNIT 1, STRATTON PARK, DUNTON LANE, BIGGLESWADE, BEDS. SG18 8QS. PHONE: (01767) 600857 FAX: (01767) 601098

©VISONETIX LTD. 2001 SPD-1000 DE3652- (REV. 5, 12/2001)

Separate warranty statement is enclosed.

www.visonetix.com



MADE IN ISRAEL