

# SR-730 PG2

## Fully Wireless PowerG Outdoor Siren

**Visonic®**

## Installation Instructions

### 1. INTRODUCTION

The SR-730 PG2 is a fully wireless outdoor siren, designed for installation in areas in which wiring action is difficult or impossible.

The siren is compatible with PowerMaster-10 control panels.

#### Features

- **Siren and strobe light activation:** When an identified event message is received from the compatible PowerMaster-10 alarm system, the siren activates its sounder & strobe light.

##### Notes:

*The sounder is activated for a predefined "Bell Time" (refer to PowerMaster-10 Installer Guide, par. 4.3), according to local authorities requirements, or until the system is disarmed, whichever occurs first.*

*The strobe light operates as described in the PowerMaster-10 Installer Guide, par. 4.3.*

- **Tamper indication:** In case of tamper while the system is armed, the siren transmits the message to the alarm system and then the alarm system determines whether the siren should be activated or not. If the siren does not receive an acknowledge message from the alarm system, the siren will function independently.
- **Low battery voltage alert**  
When the battery voltage is low, a low battery message is sent to the alarm system. After the low voltage message delivery, at least 2 siren alarms are possible before the siren is totally inactive.
- **Power Supply Options:** Non-rechargeable battery. Optional - two non-rechargeable batteries.
- **Sound Types:** Burglar (between 1400Hz - 3200Hz), fire, gas/Co and flood.
- **Entry/Exit:** Exit delay beeps sound once the user has armed the system. Entry delay beeps sound once the user has entered the protected area. (Entry/exit beeps can be enabled / disabled from the PowerMaster-10 Installer menu.)
- **Squawk indications:** Squawk (beep) sounds can be used to indicate alarm system arming (1 squawk) and disarming (2 squawks) by a keyfob (squawk can be enabled from the PowerMaster-10 User menu).
- **Strobe Light Color:** The siren can be purchased with red, blue, amber or transparent lens, according to the desired strobe light color.
- **Siren activity LED:** A flashing LED (optional, at the bottom of the siren front panel) indicates siren activity (can be disabled by the control panel)

- **Double Tamper protection:** When the siren front panel is removed or when the siren is removed from the wall, tamper alarm is sent to the alarm system.

**IMPORTANT!** The SR-730 PG2 siren must be installed on the wall in a vertical position with the screw pointing to the floor only, as illustrated in Figure 1b. The importance of correct positioning of the SR-730 PG2 is to enable the siren to function as a waterproof device.

- **2-way full supervision**

The siren is fully supervised, 2-way communication device. It includes a receiver, to receive event messages from the alarm system, and a transmitter, to periodically transmit its status signal to the alarm system.

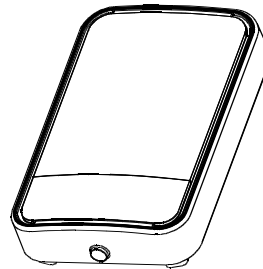

Fig. 1a - External View



A. Wall

Fig. 1b - Mounting Position

#### Self-test feature

Upon pressing the self test switch, siren functional check is performed - low level sounds and flash light indicate that the siren is serviceable.

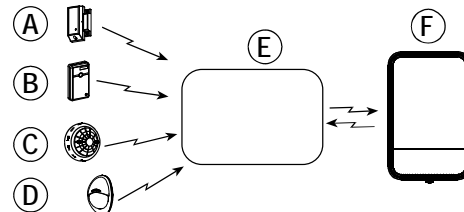

- A. Door or window open/close detector.
- B. Wireless transmitter.
- C. Smoke detector
- D. Motion detector
- E. PowerMaster-10 Control Panel
- F. SR-730 PG2

Figure 2- Typical Integration with the Alarm System

### 2. SPECIFICATIONS

**Frequency Band (MHz):** Europe: 433, 868, USA: 915

**Modulation:** GFSK

**Antenna:** Built-in antenna

**Communication Protocol:** PowerG

**Siren Type:** One Piezo 109 db min. Sound Pressure Level @ 1m, 1.4-3.2 kHz, sweep frequency 7 Hz. Additional piezo is optional.

**Power Supply:** Type C and storage device type X

**Battery Type:** 3.6V/14.5A/H Lithium battery (EVE ER34615M/w200), Visonic assembly cat. No. 0-9912-K.

**Note:** The strobe flashes 5 times and the red LED lights continuously during first battery installation.

**Note:** Use only the above battery.

#### Caution!

Risk of explosion if battery is replaced by an incorrect type. Dispose of used battery according to manufacturer's instructions.

**Battery Life Expectancy:** 8 years (for typical use)

**Strobe Light:** Pulsed @ 1 sec.

**Operating Temperature:** -33°C to 70°C (-27.4°F to 158°F), RH humidity 75%.

**Dimensions (LxWxD):** 295x186x63mm (11-5/8 x 7-5/16 x 2-1/2 in)

**Weight (including battery):** 970g (34 oz)

**Color:** White (with red, blue, amber or transparent lens)

**Compliance with Standards:**

**Europe:** EN50131-1 Grade 2 Class 4, EN 50131-4, EN 50131-6, EN 301489, EN 50130-4, EN 50130-5, EN 300 220, EN 60950-1, EN 60950-22

Environmental IP55.

**USA:** CFR47 Part 15

**Canada:** RSS 210

**Note:** The manufacturer is not responsible for any radio or TV interference caused by unauthorized modifications to this equipment. Such modifications could void the user's authority to operate the equipment.

**Interference Prevention**

This device complies with FCC Rules Part 15. Operation is subject to two conditions: (1) This device may not cause harmful interference, and (2) this device must accept any interference that may be received or that may cause undesired operation.

The digital circuit of this device has been tested and found to comply with the limits for a Class B digital device, pursuant to

Part 15 of the FCC Rules. These limits are designed to provide reasonable protection against harmful interference in residential installations. This equipment generates, uses and can radiate radio frequency energy and, if not installed and used in accordance with the instructions, may cause harmful interference to radio and television reception. However, there is no guarantee that interference will not occur in a particular installation. If this device does cause such interference, which can be verified by turning the device off and on, the user is encouraged to eliminate the interference by one or more of the following measures:

- Re-orient or re-locate the receiving antenna.
- Increase the distance between the device and the receiver.
- Connect the device to an outlet on a circuit different from the one which supplies power to the receiver.
- Consult the dealer or an experienced radio/TV technician.

Changes or modifications not expressly approved by Visonic Ltd. could void the user's authority to operate the equipment.

**3. INSTALLATION**

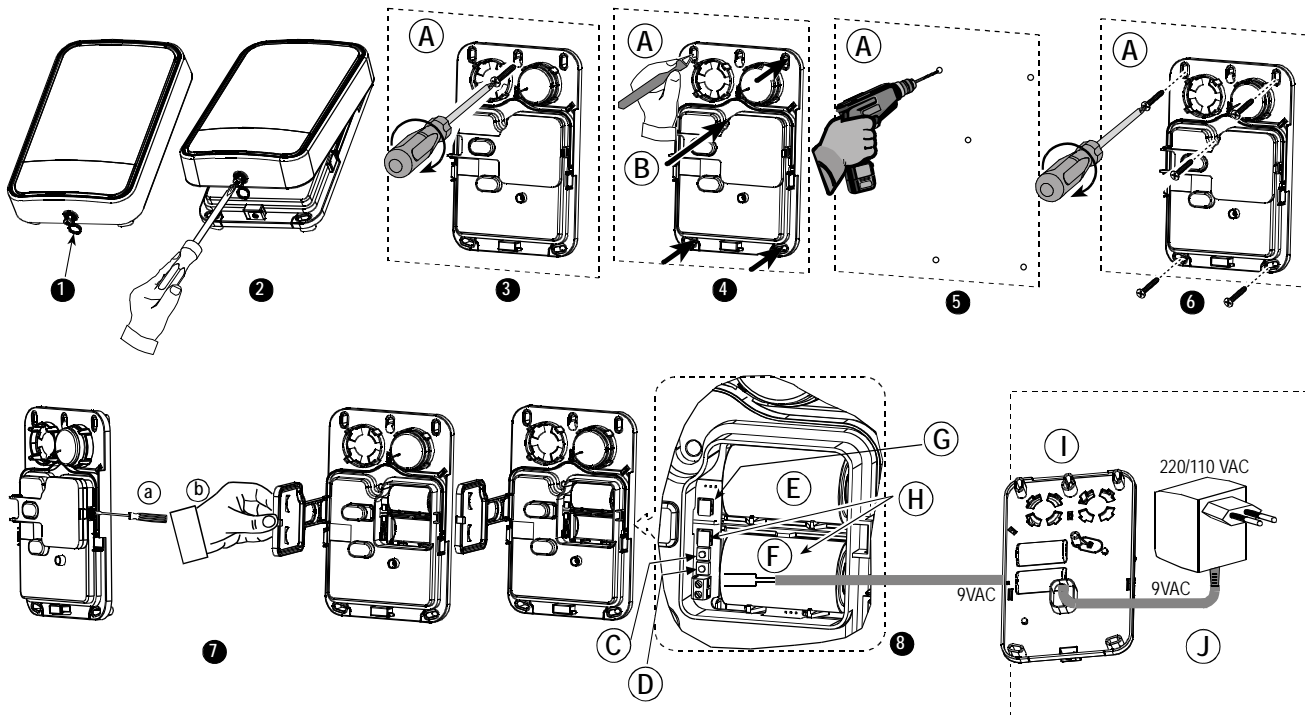

1. Open plastic cover screw.
2. Using Philips screwdriver, remove screw and remove cover.
3. Optional step: Hang back unit with a screw on mounting surface to make the next step (drilling marking) easier.
4. Mark for drilling.
5. Drill 5 holes.
6. Fasten with 5 screws.
7. Release catch (A) and open battery cover (B).
8. Connect battery / optional battery and 9VAC power to the proper connectors and set the optional jumpers as desired.

- A. Mounting surface.
- B. For tamper.
- C. Self-Test button.
- D. Enroll button.
- E. Primary battery.
- F. Secondary battery.
- G. Battery connector.
- H. Optional second battery and its connector.
- I. Siren rear side.

J. When external power is used, set the AC Enable (ON) / Disable (OFF) jumper to Enable position (see step 8).

**Note:** There are SR-730 PG2 model variations that are supplied with battery only, or, with battery and AC adaptor.

**Figure 3: Installation**

**WARNING:** To comply with FCC RF exposure compliance requirements, the siren should be located in a distance of at least 20 cm from all persons during normal operation. The antennas used for this product must not be co-located or operated in conjunction with any other antenna or transmitter.

## 4. ENROLLMENT

























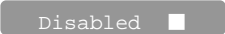















Refer to the PowerMaster-10 Installer Guide for the device enrollment procedure.

## 5. MODIFY DEVICE SETTINGS

This section describes how to configure the parameters of the siren from the PowerMaster-10 control panel.

### To Modify the Siren Device Settings

Refer to the PowerMaster-10 Installer Guide and perform the procedure for Adding A Wireless Device (section 4.5.2), or, Modifying a Device (section 4.5.5). Then continue below to modify the device settings.

1.    
  Here you determine the mode in which the strobe alarm will operate.
2.    
3.  Select between "Timer limited", "Disabled" and "Until Disarmed".
4.  
5.   Here you determine whether or not to activate the exit – entry beeps, and if enabled, whether to activate in HOME or AWAY mode.
6.  
7.  Select between "Disabled", "Disabled & Home" and "Enabled".
8.  
9.   Here you determine whether or not to activate the squawk, and if enabled, whether to activate the sounder only, or, the sounder and strobe simultaneously.
10.  
11.  Select between "Disabled", "Sounder only" and "Sounder+strobe".
12.  
13.   Here you determine the volume level of the sounder.
14.  
15.  Select between "Volume HIGH", "Volume LOW" and "Volume MID".
16.  
17.   Here you determine whether or not the LED will be activated to indicate that the siren is operating.
18.  
19.  Select between "Disabled", and "Enabled".
20.  
21.   Here you determine whether or not to report a power failure and restore.

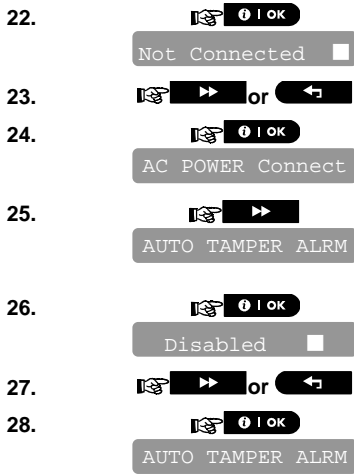

Select between "Not Connected" and "Connected to AC".

Here you determine whether or not the siren alone will sound a tamper alarm when there is no communication between the siren and the control panel.

Select between "Disabled" and "Enabled".

When exiting "ZONES / DEVICES" menu, the PowerMaster-10 system displays the number of devices that need to be updated, as follows: DEV UPDATING NNN.

For detailed instructions on Adding Devices, Deleting Devices, Replacing Devices and Defining Defaults see the PowerMaster-10 Installer Guide.

## 6. LOCAL DIAGNOSTICS TEST

Before testing, remove the plastic cover and then open the battery cover (see Fig. 3).

A. Press the self-test button once and release it; the following procedure should occur in turn:

The red LED will switch ON and then OFF, the green LED will switch ON and then OFF, the strobe light will switch ON and then OFF and the piezo siren will sound to indicate that the siren is now fully operational.

B. After 2 seconds the LED blinks 3 times.

The following table indicates received signal strength indication.

LED response	Reception
Green LED blinks	Strong
Orange LED blinks	Good
Red LED blinks	Poor
No blinks	No communication

**IMPORTANT!** Reliable reception must be assured. Therefore, "poor" signal strength is not acceptable. If you receive a "poor" signal from the device, re-locate it and re-test until a "good" or "strong" signal strength is received.

**Note:** For detailed Diagnostics Test instructions refer to PowerMaster-10 Installer Guide.

### WARRANTY

Visonic Limited (the "Manufacturer") warrants this product only (the "Product") to the original purchaser only (the "Purchaser") against defective workmanship and materials under normal use of the Product for a period of twelve (12) months from the date of shipment by the Manufacturer.

This Warranty is absolutely conditional upon the Product having been properly installed, maintained and operated under conditions of normal use in accordance with the Manufacturers recommended installation and operation instructions. Products which have become defective for any other reason, according to the Manufacturers discretion, such as improper installation, failure to follow recommended installation and operational instructions, neglect, willful damage, misuse or vandalism, accidental damage, alteration or tampering, or repair by anyone other than the manufacturer, are not covered by this Warranty.

The Manufacturer does not represent that this Product may not be compromised and/or circumvented or that the Product will prevent any death and/or personal injury and/or damage to property resulting from burglary, robbery, fire or otherwise, or that the Product will in all cases provide adequate warning or protection. The Product, properly installed and maintained, only reduces the risk of such events without warning and it is not a guarantee or insurance that such events will not occur.

**THIS WARRANTY IS EXCLUSIVE AND EXPRESSLY IN LIEU OF ALL OTHER WARRANTIES, OBLIGATIONS OR LIABILITIES, WHETHER WRITTEN, ORAL, EXPRESS OR IMPLIED, INCLUDING ANY WARRANTY OF MERCHANTABILITY OR FITNESS FOR A PARTICULAR PURPOSE, OR OTHERWISE. IN NO CASE SHALL THE MANUFACTURER BE LIABLE TO ANYONE FOR ANY CONSEQUENTIAL OR INCIDENTAL DAMAGES FOR BREACH OF THIS WARRANTY OR ANY OTHER WARRANTIES WHATSOEVER, AS AFORESAID.**

**THE MANUFACTURER SHALL IN NO EVENT BE LIABLE FOR ANY SPECIAL, INDIRECT, INCIDENTAL, CONSEQUENTIAL OR PUNITIVE DAMAGES OR FOR LOSS, DAMAGE, OR EXPENSE, INCLUDING LOSS OF USE, PROFITS, REVENUE, OR GOODWILL, DIRECTLY OR INDIRECTLY ARISING FROM PURCHASER'S USE OR INABILITY TO USE THE PRODUCT, OR FOR LOSS OR DESTRUCTION OF OTHER PROPERTY OR FROM ANY OTHER CAUSE, EVEN IF MANUFACTURER HAS BEEN ADVISED OF THE POSSIBILITY OF SUCH DAMAGE.**

**THE MANUFACTURER SHALL HAVE NO LIABILITY FOR ANY DEATH, PERSONAL AND/OR BODILY INJURY AND/OR DAMAGE TO PROPERTY OR OTHER LOSS WHETHER DIRECT, INDIRECT, INCIDENTAL, CONSEQUENTIAL OR OTHERWISE, BASED ON A CLAIM THAT THE PRODUCT FAILED TO FUNCTION.**

However, if the Manufacturer is held liable, whether directly or indirectly, for any loss or damage arising under this limited warranty, **THE MANUFACTURER'S MAXIMUM LIABILITY (IF ANY) SHALL NOT IN ANY CASE EXCEED THE PURCHASE PRICE OF THE PRODUCT**, which shall be fixed as liquidated damages and not as a penalty, and shall be the complete and exclusive remedy against the Manufacturer.

When accepting the delivery of the Product, the Purchaser agrees to the said conditions of sale and warranty and he recognizes having been informed of.

Some jurisdictions do not allow the exclusion or limitation of incidental or consequential damages, so these limitations may not apply under certain circumstances.

The Manufacturer shall be under no liability whatsoever arising out of the corruption and/or malfunctioning of any telecommunication or electronic equipment or any programs.

The Manufacturers obligations under this Warranty are limited solely to repair and/or replace at the Manufacturer's discretion any Product or part thereof that may prove defective. Any repair and/or replacement shall not extend the original Warranty period. The Manufacturer shall not be responsible for dismantling and/or re-installation costs. To exercise this Warranty the Product must be returned to the Manufacturer freight pre-paid and insured. All freight and insurance costs are the responsibility of the Purchaser and are not included in this Warranty.

This warranty shall not be modified, varied or extended, and the Manufacturer does not authorize any person to act on its behalf in the modification, variation or extension of this warranty. This warranty shall apply to the Product only. All products, accessories or attachments of others used in conjunction with the Product, including batteries, shall be covered solely by their own warranty, if any. The Manufacturer shall not be liable for any damage or loss whatsoever, whether directly, indirectly, incidentally, consequentially or otherwise, caused by the malfunction of the Product due to products, accessories, or attachments of others, including batteries, used in conjunction with the Products. This Warranty is exclusive to the original Purchaser and is not assignable.

This Warranty is in addition to and does not affect your legal rights. Any provision in this warranty which is contrary to the Law in the state or country where the Product is supplied shall not apply.

**Warning:** The user must follow the Manufacturer's installation and operational instructions including testing the Product and its whole system at least once a week and to take all necessary precautions for his/her safety and the protection of his/her property.

1/08



#### W.E.E. Product Recycling Declaration

For information regarding the recycling of this product you must contact the company from which you originally purchased it. If you are discarding this product and not returning it for repair then you must ensure that it is returned as identified by your supplier. This product is not to be thrown away with everyday waste. Directive 2002/96/EC Waste Electrical and Electronic Equipment.



VISONIC LTD. (ISRAEL): P.O.B 22020 TEL-AVIV 61220 ISRAEL. PHONE: (972-3) 645-6789. FAX: (972-3) 645-6788  
 VISONIC INC. (U.S.A.): 65 WEST DUDLEY TOWN ROAD, BLOOMFIELD CT. 06002-1376. PHONE: (860) 243-0833, (800) 223-0020.  
 FAX: (860) 242-8094

VISONIC LTD. (UK): UNIT 6 MADINGLEY COURT CHIPPENHAM DRIVE KINGSTON MILTON KEYNES MK10 0BZ. TEL: (0870) 7300800  
 FAX: (0870) 7300801. TEL: (0870) 7300800 FAX: (0870) 7300801 **PRODUCT SUPPORT: (0870) 7300830**

VISONIC GmbH (D-A-CH): KIRCHFELDSTR. 118, D-40215 DUISSELDORF, TEL.: +49 (0)211 600696-0, FAX: +49 (0)211 600696-19  
 VISONIC IBERICA: ISLA DE PALMA, 32 NAVE 7, POLIGONO INDUSTRIAL NORTE, 28700 SAN SEBASTIÁN DE LOS REYES, (MADRID), ESPAÑA.  
 TEL (34) 91659-3120, FAX (34) 91663-8468. www.visonic-iberica.es  
 INTERNET: www.visonic.com

©VISONIC LTD. 2010 SR-730 PG2 D-302414 (REV. 1, 12/10)



MADE IN ISRAEL